

RADIATION HARDENED N-CHANNEL MOSFET

Reference MIL-PRF-19500/603

DEVICES

2N7269 2N7269U

LEVELS

**JANSR (100K RAD(Si))
 JANSF (300K RAD(Si))**

ABSOLUTE MAXIMUM RATINGS ($T_C = +25^\circ\text{C}$ unless otherwise noted)

Parameters / Test Conditions	Symbol	Value	Unit
Drain – Source Voltage	V_{DS}	200	Vdc
Gate – Source Voltage	V_{GS}	± 20	Vdc
Continuous Drain Current $T_C = +25^\circ\text{C}$	I_{D1}	26.0	Adc
Continuous Drain Current $T_C = +100^\circ\text{C}$	I_{D2}	16.0	Adc
Max. Power Dissipation	P_{tl}	150 ⁽¹⁾	W
Drain to Source On State Resistance	$R_{ds(on)}$	0.100 ⁽²⁾	Ω
Operating & Storage Temperature	T_{op}, T_{stg}	-55 to +150	$^\circ\text{C}$

Note: (1) Derated Linearly by 1.2 W/ $^\circ\text{C}$ for $T_C > +25^\circ\text{C}$
 (2) $V_{GS} = 12\text{Vdc}$, $I_D = 16.0\text{A}$

PRE-IRRADIATION ELECTRICAL CHARACTERISTICS ($T_A = +25^\circ\text{C}$, unless otherwise noted)

Parameters / Test Conditions	Symbol	Min.	Max.	Unit
Drain-Source Breakdown Voltage $V_{GS} = 0\text{V}$, $I_D = 1\text{mA}$	$V_{(BR)DSS}$	200		Vdc
Gate-Source Voltage (Threshold) $V_{DS} \geq V_{GS}$, $I_D = 1.0\text{mA}$ $V_{DS} \geq V_{GS}$, $I_D = 1.0\text{mA}$, $T_j = +125^\circ\text{C}$ $V_{DS} \geq V_{GS}$, $I_D = 1.0\text{mA}$, $T_j = -55^\circ\text{C}$	$V_{GS(th)1}$ $V_{GS(th)2}$ $V_{GS(th)3}$	2.0 1.0	4.0 5.0	Vdc
Gate Current $V_{GS} = \pm 20\text{V}$, $V_{DS} = 0\text{V}$ $V_{GS} = \pm 20\text{V}$, $V_{DS} = 0\text{V}$, $T_j = +125^\circ\text{C}$	I_{GSS1} I_{GSS2}		± 100 ± 200	nAdc
Drain Current $V_{GS} = 0\text{V}$, $V_{DS} = 160\text{V}$ $V_{GS} = 0\text{V}$, $V_{DS} = 200\text{V}$, $T_j = +125^\circ\text{C}$ $V_{GS} = 0\text{V}$, $V_{DS} = 160\text{V}$, $T_j = +125^\circ\text{C}$	I_{DSS1} I_{DSS2} I_{DSS3}		25 1.0 0.25	μAdc mAdc mAdc
Static Drain-Source On-State Resistance $V_{GS} = 12\text{V}$, $I_D = 16.0\text{A}$ pulsed $V_{GS} = 12\text{V}$, $I_D = 26.0\text{A}$ pulsed $T_j = +125^\circ\text{C}$ $V_{GS} = 12\text{V}$, $I_D = 16.0\text{A}$ pulsed	$r_{DS(on)1}$ $r_{DS(on)2}$ $r_{DS(on)3}$		0.100 0.110 0.200	Ω Ω Ω
Diode Forward Voltage $V_{GS} = 0\text{V}$, $I_D = 26.0\text{A}$ pulsed	V_{SD}		1.4	Vdc

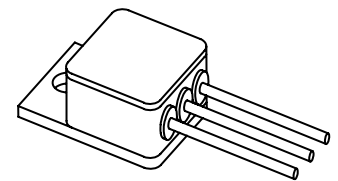

TO-254AA
JANSR2N7269, JANSF2N7269
 See Figure 1

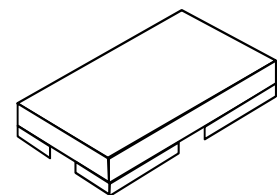

U-PKG (SMD-1)
(TO-267AB)
JANSR2N7269U, JANSF2N7269U
 See Figure 2

RADIATION HARDENED N-CHANNEL MOSFET

Reference MIL-PRF-19500/603

DYNAMIC CHARACTERISTICS

Parameters / Test Conditions	Symbol	Min.	Max.	Unit
Gate Charge: On-State Gate Charge Gate to Source Charge Gate to Drain Charge	$Q_{g(on)}$ Q_{gs} Q_{gd}		170 30 60	nC
		$V_{GS} = 12V, I_D = 26.0A$ $V_{DS} = 100V$		

SWITCHING CHARACTERISTICS

Parameters / Test Conditions	Symbol	Min.	Max.	Unit
Switching time tests: Turn-on delay time Rinse time Turn-off delay time Fall time	$t_{d(on)}$ t_r $t_{d(off)}$ t_f		33 140 140 140	ns
		$I_D = 26.0A, V_{GS} = 12Vdc,$ Gate drive impedance = $2.35\Omega,$ $V_{DD} = 50Vdc$		
Diode Reverse Recovery Time	t_{rr}		820	ns
		$di/dt \leq 100A/\mu s, V_{DD} \leq 30V,$ $I_F = 26.0A$		

POST-IRRADIATION ELECTRICAL CHARACTERISTICS (3) ($T_A = +25^\circ C$, unless otherwise noted)

Parameters / Test Conditions	Symbol	Min.	Max.	Unit
Drain-Source Breakdown Voltage $V_{GS} = 0V, I_D = 1mA$	$V_{(BR)DSS}$	200		Vdc
Gate-Source Voltage (Threshold) $V_{DS} \geq V_{GS}, I_D = 1.0mA$ MSR $V_{DS} \geq V_{GS}, I_D = 1.0mA$ MSF	$V_{GS(th)1}$ $V_{GS(th)1}$	2.0 1.25	4.0 4.5	Vdc
Gate Current $V_{GS} = \pm 20V, V_{DS} = 0V$	I_{GSS1}		± 100	nA dc
Drain Current $V_{GS} = 0V, V_{DS} = 160V$ MSR $V_{GS} = 0V, V_{DS} = 160V$ MSF	I_{DSS1}		25 50	μA dc
Static Drain-Source On-State Voltage $V_{GS} = 12V, I_D = 16.0A$ pulsed MSR $V_{GS} = 12V, I_D = 16.0A$ pulsed MSF	$V_{DS(on)}$		1.6 2.48	Vdc
Diode Forward Voltage $V_{GS} = 0V, I_D = 26.0A$ pulsed	V_{SD}		1.4	Vdc

NOTE:

- (3) Post-Irradiation Electrical Characteristics apply to devices subjected to Steady State Total Dose Irradiation testing in accordance with MIL-STD-750 Method 1019. Separate samples are tested for VGS bias (12V), and VDS bias (160V) conditions.

RADIATION HARDENED N-CHANNEL MOSFET

Reference MIL-PRF-19500/603

Single Event Effect (SEE) Characteristics:

Heavy Ion testing of the 2N7269 device was completed by similarity of die structure to the 2N7262. The 2N7262 has been characterized at the Texas A&M cyclotron. The following SOA curve has been established using the elements, LET, range, and Total Energy conditions as shown:

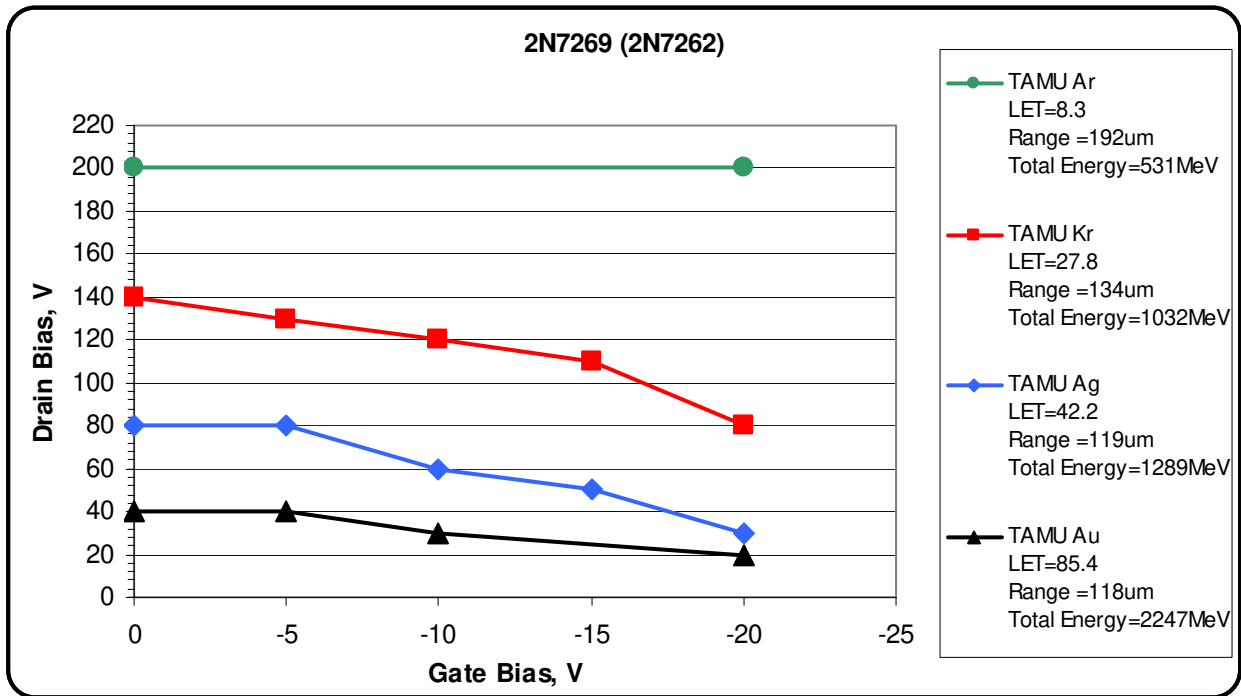

It should be noted that total energy levels are considered to be a factor in SEE characterization. Comparisons to other datasets should not be based on LET alone. Please consult factory for more information.

6 Lake Street, Lawrence, MA 01841
 1-800-446-1158 / (978) 620-2600 / Fax: (978) 689-0803
 Website: <http://www.microsemi.com>

RADIATION HARDENED N-CHANNEL MOSFET

Reference MIL-PRF-19500/603

Symbol	Dimensions			
	Inches		Millimeters	
	Min	Max	Min	Max
BL	.535	.545	13.59	13.84
CH	.249	.260	6.32	6.60
LD	.035	.045	0.89	1.14
LL	.510	.570	12.95	14.48
LO	.150 BSC		3.81 BSC	
LS	.150 BSC		3.81 BSC	
MHD	.139	.149	3.53	3.78
MHO	.665	.685	16.89	17.40
TL	.790	.800	20.07	20.32
TT	.040	.050	1.02	1.27
TW	.535	.545	13.59	13.84
Term 1	Drain			
Term 2	Source			
Term 3	Gate			

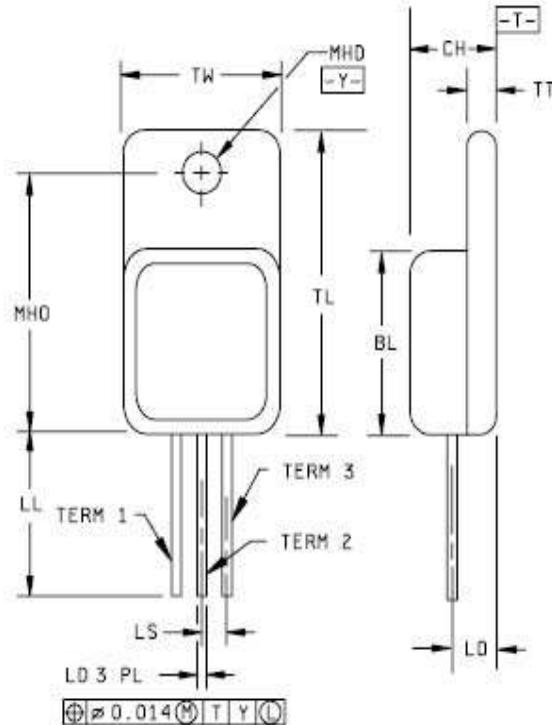

NOTES:

1. Dimensions are in inches.
2. Millimeters are given for general information only.
3. Refer to applicable symbol list.
4. In accordance with ASME Y14.5M, diameters are equivalent to ϕx symbology.
5. All terminals are isolated from case.

Figure 1: Case Outline and Pin Configuration for JANSR2N7269 & JANSF2N7269

6 Lake Street, Lawrence, MA 01841
 1-800-446-1158 / (978) 620-2600 / Fax: (978) 689-0803
 Website: <http://www.microsemi.com>

RADIATION HARDENED N-CHANNEL MOSFET

Reference MIL-PRF-19500/603

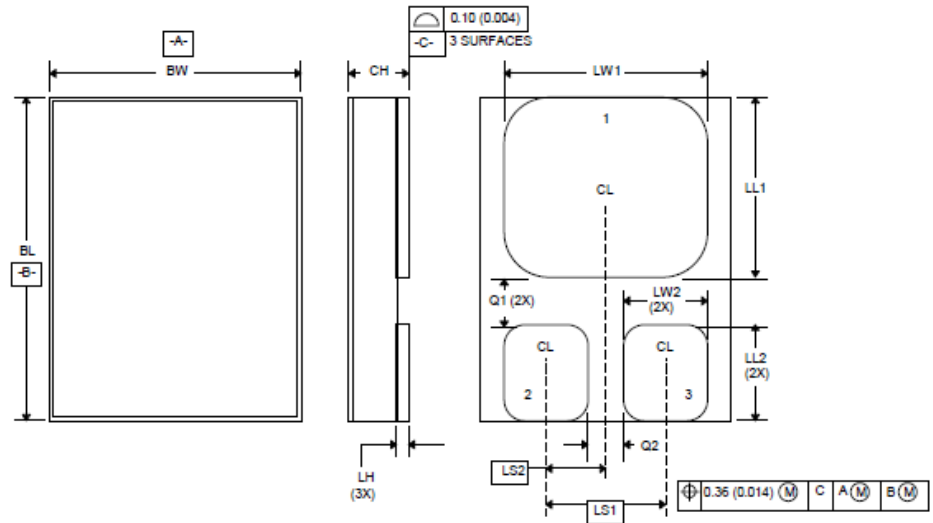

NOTES:

1. Dimensions are in inches.
2. Millimeters are given for general information only.
3. The lid shall be electrically isolated from the drain, gate and source.
4. In accordance with ASME Y14.5M, diameters are equivalent to ϕ x symbology.

Symbol	Dimensions			
	SMD-1			
	Inches		Millimeters	
	Min	Max	Min	Max
BL	.620	.630	15.75	16.00
BW	.445	.455	11.30	11.56
CH		.142		3.60
LH	.010	.020	0.26	0.50
LL ₁	.410	.420	10.41	10.67
LL ₂	.152	.162	3.86	4.11
LS ₁	.210 BSC		5.33 BSC	
LS ₂	.105 BSC		2.67 BSC	
LW ₁	.370	.380	9.40	9.65
LW ₂	.135	.145	3.43	3.68
Q ₁	.030		0.76	
Q ₂	.035		0.89	
Term 1	Drain			
Term 2	Gate			
Term 3	Source			

Figure 2: Case Outline and Pin Configuration for JANSR2N7269U & JANSF2N7269U