

THIS COPY IS PROVIDED ON A RESTRICTED BASIS AND IS NOT TO BE USED IN ANY WAY DETRIMENTAL TO THE INTERESTS OF PANDUIT CORP.

PANDUIT PART #	WIRE RANGE AWG [mm ²]	DIMENSIONS in. [mm]		
		L ± .02 [0,51]	B DIA. ± .01 [0,25]	C ± .01 [0,25]
BS18	#22-18 [0,5-1,0]	.62 [15,7]	.14 [3,6]	.032 [0,81]
BS14	#16-14 [1,5-2,5]	.62 [15,7]	.16 [4,1]	.032 [0,81]
BS10	#12-10 [4,0-6,0]	.63 [16,0]	.22 [5,6]	.040 [1,02]

- NOTES:
- USED FOR:
 - SOLID OR STRANDED COPPER WIRE
 - 302°F [150°C] MAX. TEMPERATURE RATING
 - INSTALLATION TOOLS:
 - UL LISTED AND CSA CERTIFIED: CT-100A, CT-200, CT-600A (CT-570CH), CT-1570, CT-2500 (CT-2570CH)
 - PANDUIT APPROVED: CT-160, CT-260
 - WIRE STRIP LENGTH: 9/32 ^{+1/32}/₀ [7,1 ^{+0,8}/₀]
 - MATERIAL:
 - STAMPING: COPPER, TIN PLATED
 - SEE www.panduit.com FOR PACKAGE QUANTITIES INDICATED BY PART NUMBER SUFFIX
 - DIMENSIONS IN BRACKETS ARE METRIC EQUIVALENT

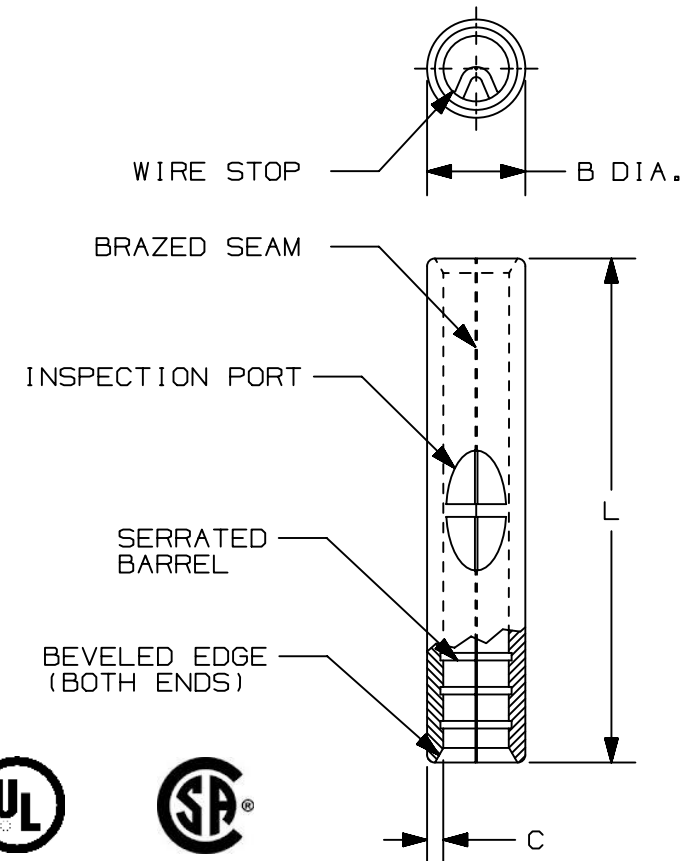

REV	DATE	BY	CHK	APR	DESCRIPTION	ECN
08	09.06.12	JBN	LCA	VMB	REVISED NOTES. ADDED METRIC EQUIVALENTS. UPDATED DRAWING TO CURRENT STANDARD.	A41338

TITLE		BUTT SPLICE, NON- INSULATED #22-10		
		CUSTOMER DRAWING		
ITEM REVISION NAME		N41338BA/08		
DATASET FILE NAME		N41338BA_DC/08A		
UNLESS OTHERWISE SPECIFIED, DIMENSIONAL TOLERANCES ARE: IN [mm]		PANDUIT TM		
.x ± .1 [2.54] .xxx ± .005 [.13] .xx ± .01 [.25] ANGLES ± 5 °				
DRAWING NUMBER:		A41338		
DRAWN BY	DATE	CHK	SCALE	SIZE
DAW	-	-	N.T.S	A

D10100DA/12