

- ① CONTACTS: PHOSPHOR BRONZE.
SHELL: CARBON STEEL
HOUSING: POLYESTER, BLACK, UL 94V-0 RATED.
TERMINATING COVERS: POLYESTER, UL 94V-0 RATED; COLOR: SEE TABLE.
- ② 0.76µm [.000030] MIN GOLD FOR A LENGTH OF 0.64 [.025] MIN, 0.13 [.005] MAX FROM MATING END, 1.27µm [.000050] MIN TIN-LEAD IN TERMINATION AREA, BOTH OVER 1.27µm [.000050] MIN NICKEL.
- ③ 5.08µm [.000200] MIN NICKEL OVER 1.27µm [.000050] MIN COPPER.
- ④ RECOMMENDED WIRE: 30 AWG - 28 AWG, SEE TABLE FOR INSULATION DIA.
- 5. COVERS PACKAGED SEPARATE FROM CONNECTORS IN SAME SHIPPING CONTAINER.
- ⑥ OBSOLETE PART NUMBER.
- ⑦ 0.76µm [.000030] MIN GOLD FOR A LENGTH OF 0.64 [.025] MIN, 0.13 [.005] MAX FROM MATING END, 3.00µm [.000100] MIN TIN IN TERMINATION AREA, BOTH OVER 1.27µm [.000050] MIN NICKEL. AREA, BOTH OVER 1.27µm [.000050] MIN NICKEL.
- ⑧ SUPERSEDED BY 5786860-7.

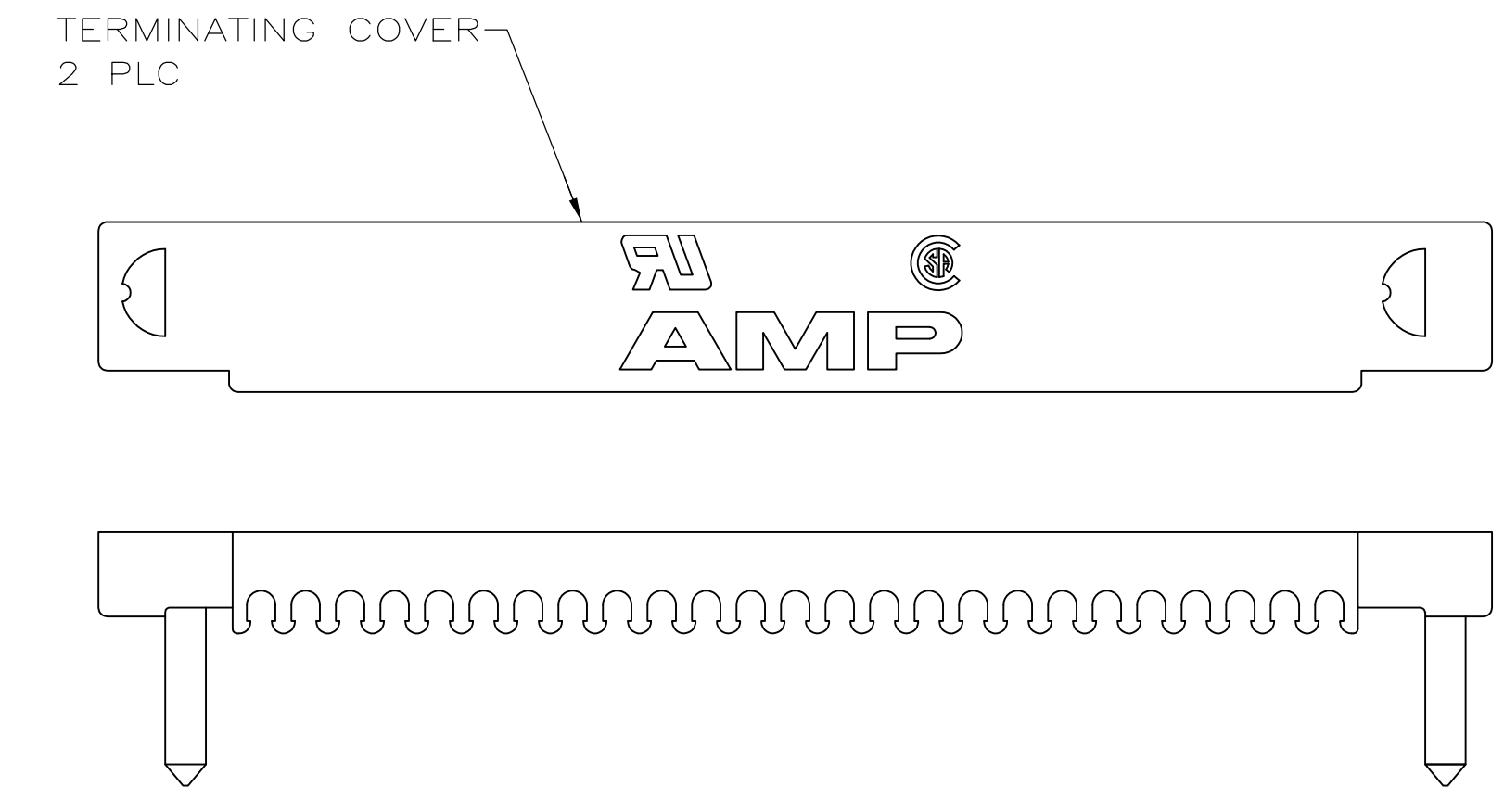

OBSOLETE

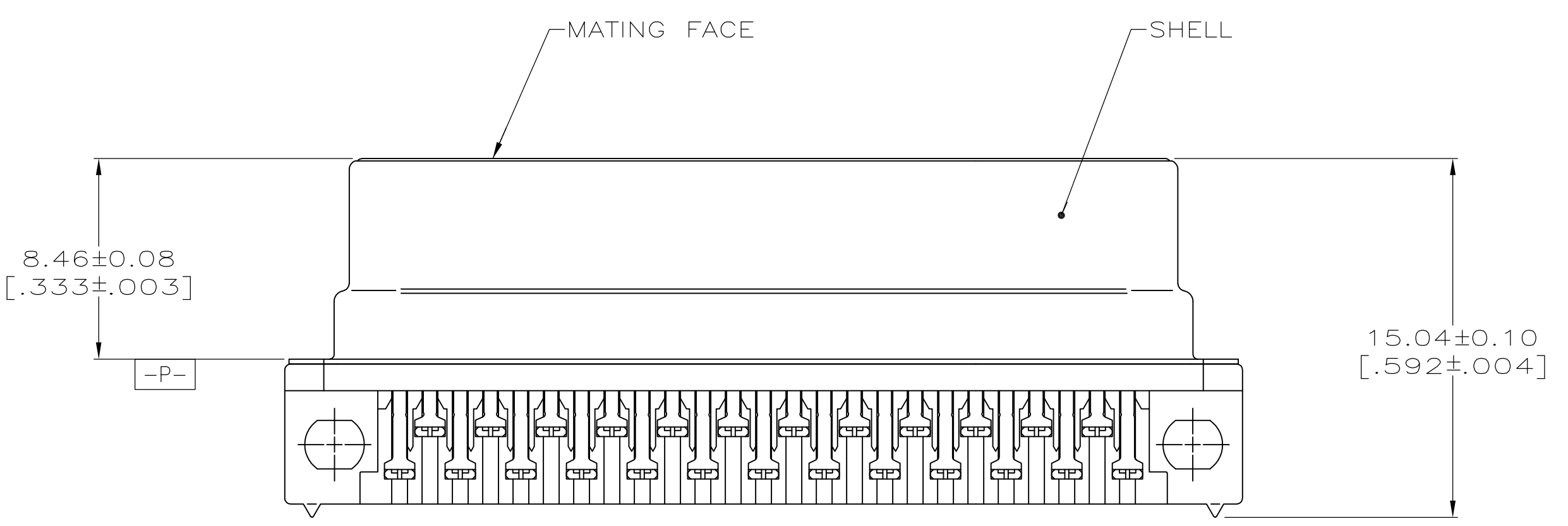
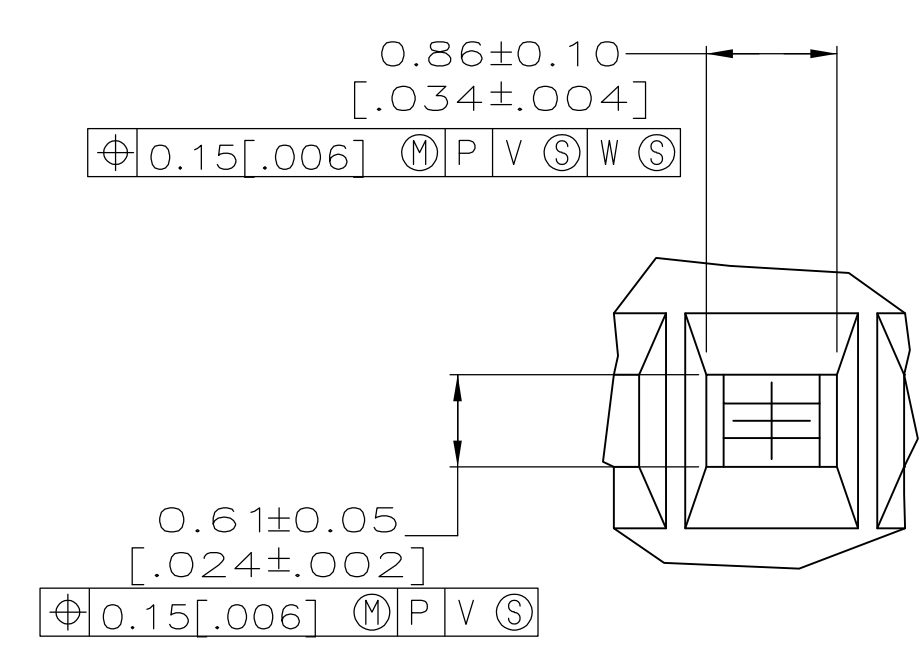
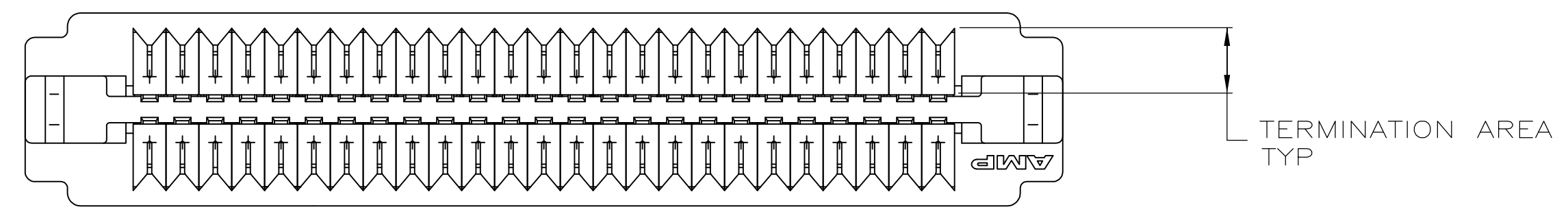
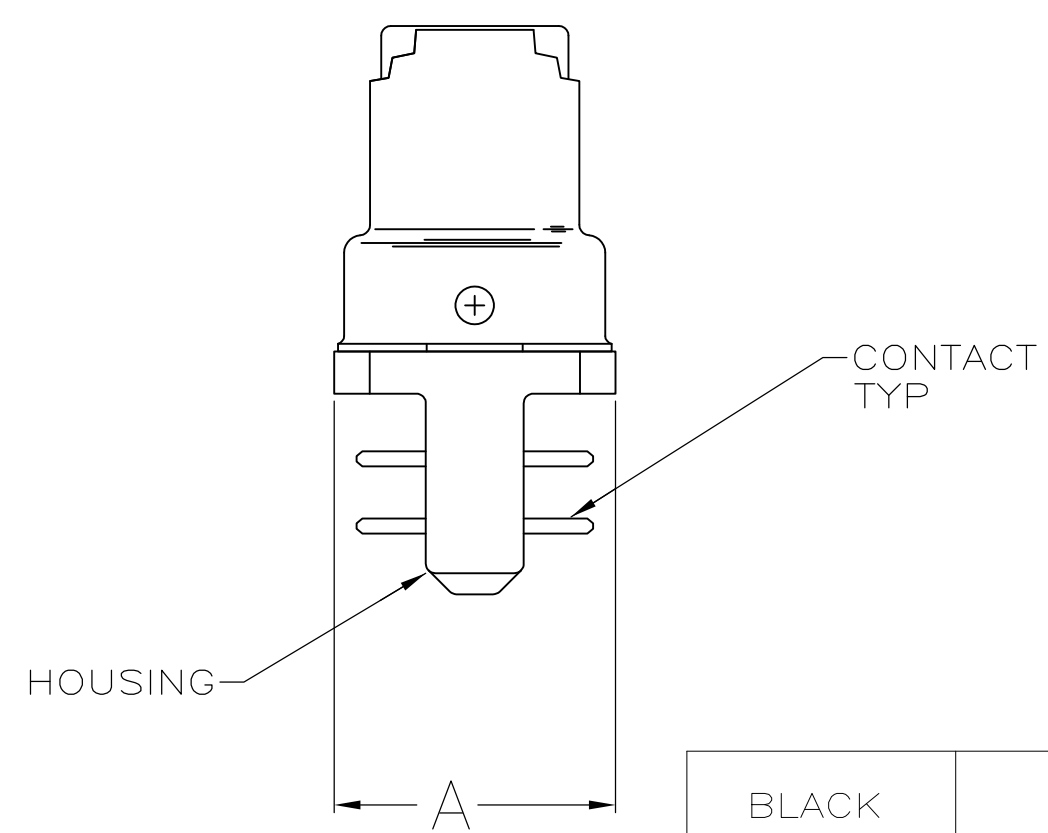

DETAIL T
SCALE 20:1
TYPICAL

COVERS COLOR	CONTACT FINISH	WIRE OUTER DIA	G	D	C	B	A	NO OF POSN	REVISIONS
BLACK	⑦	0.81-0.91 DIA [.032-.036]	20.96 [.825]	51.54 [2.029]	46.13 [1.816]	41.91 [1.650]	7.39 [.291]	68	⑧ 2-786860-0
GRAY	⑦	0.74-0.79 DIA [.029-.031]	31.12 [1.225]	71.86 [2.829]	66.45 [2.616]	62.23 [2.450]	9.42 [.371]	100	⑥ 1-786860-9
GRAY	⑦	0.74-0.79 DIA [.029-.031]	20.96 [.825]	51.54 [2.029]	46.13 [1.816]	41.91 [1.650]	7.39 [.291]	68	⑥ 1-786860-7
GRAY	⑦	0.74-0.79 DIA [.029-.031]	15.24 [.600]	40.11 [1.579]	34.70 [1.366]	30.48 [1.200]	7.39 [.291]	50	⑥ 1-786860-5
GRAY	⑦	0.74-0.79 DIA [.029-.031]	12.06 [.475]	33.76 [1.329]	28.35 [1.116]	24.13 [.950]	7.39 [.291]	40	⑥ 1-786860-4
GRAY	⑦	0.74-0.79 DIA [.029-.031]	7.62 [.300]	24.87 [.979]	19.46 [.766]	15.24 [.600]	7.39 [.291]	26	⑥ 1-786860-2
BLACK	⑦	0.81-0.91 DIA [.032-.036]	31.12 [1.225]	71.86 [2.829]	66.45 [2.616]	62.23 [2.450]	9.42 [.371]	100	⑥ 786860-9
BLACK	⑦	0.81-0.91 DIA [.032-.036]	20.96 [.825]	51.54 [2.029]	46.13 [1.816]	41.91 [1.650]	7.39 [.291]	68	⑥ 786860-7
BLACK	⑦	0.81-0.91 DIA [.032-.036]	15.24 [.600]	40.11 [1.579]	34.70 [1.366]	30.48 [1.200]	7.39 [.291]	50	⑥ 786860-5
BLACK	⑦	0.81-0.91 DIA [.032-.036]	12.06 [.475]	33.76 [1.329]	28.35 [1.116]	24.13 [.950]	7.39 [.291]	40	⑥ 786860-4
BLACK	⑦	0.81-0.91 DIA [.032-.036]	7.62 [.300]	24.87 [.979]	19.46 [.766]	15.24 [.600]	7.39 [.291]	26	⑥ 786860-2

THIS DRAWING IS A CONTROLLED DOCUMENT.

DIMENSIONS: mm [INCHES]	TOLERANCES UNLESS OTHERWISE SPECIFIED:	DIN C. COBERMAN 04/27/93	APVD
0 PLC ± -	1 PLC ± -	5-10-93	
2 PLC ± 0.13 [.005]	3 PLC ± -		
4 PLC ± -	ANGLES ± -		

MATERIAL: ⑦ FINISH: ⑦ SHELL: ⑦ CONTACTS: SEE TABLE

RECEIPTABLE CABLE CONNECTOR KIT, UNASSEMBLED, WITH TERMINATING COVER, .050 SERIES, AMPLIMITE

SIZE: A1 00779 C=786860

SCALE: 5:1 SHEET: 1 OF 1 REV: K