

PART NUMBER
10119472-001LF
10119472-002LF

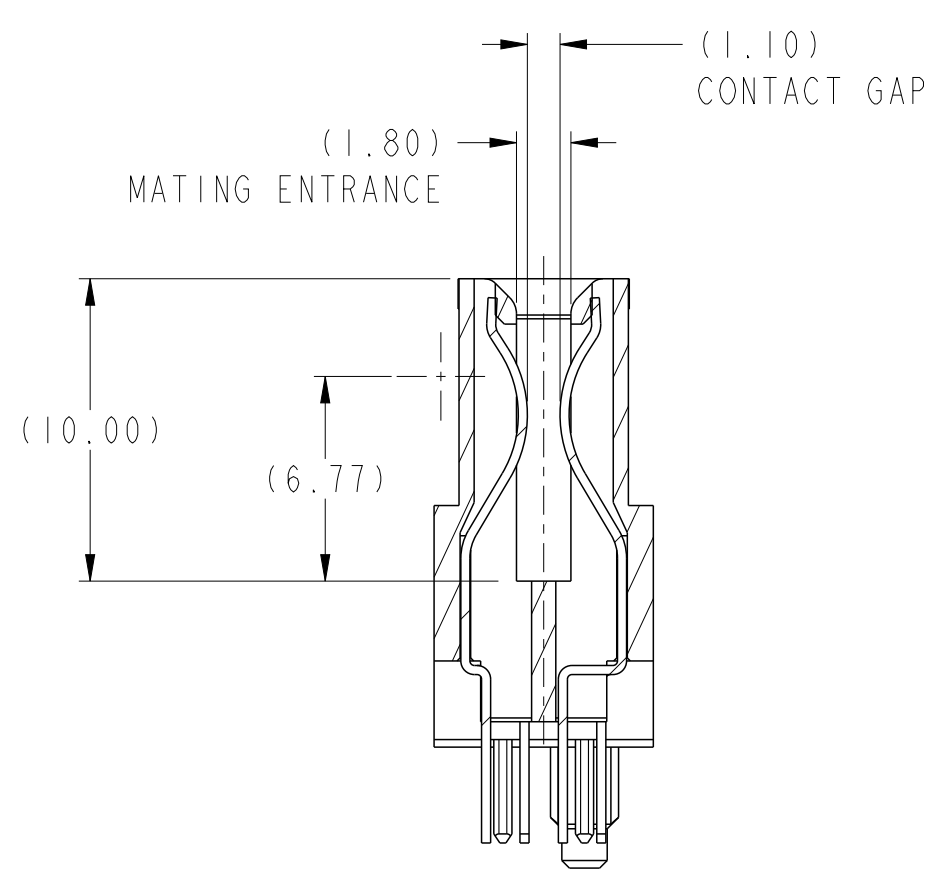
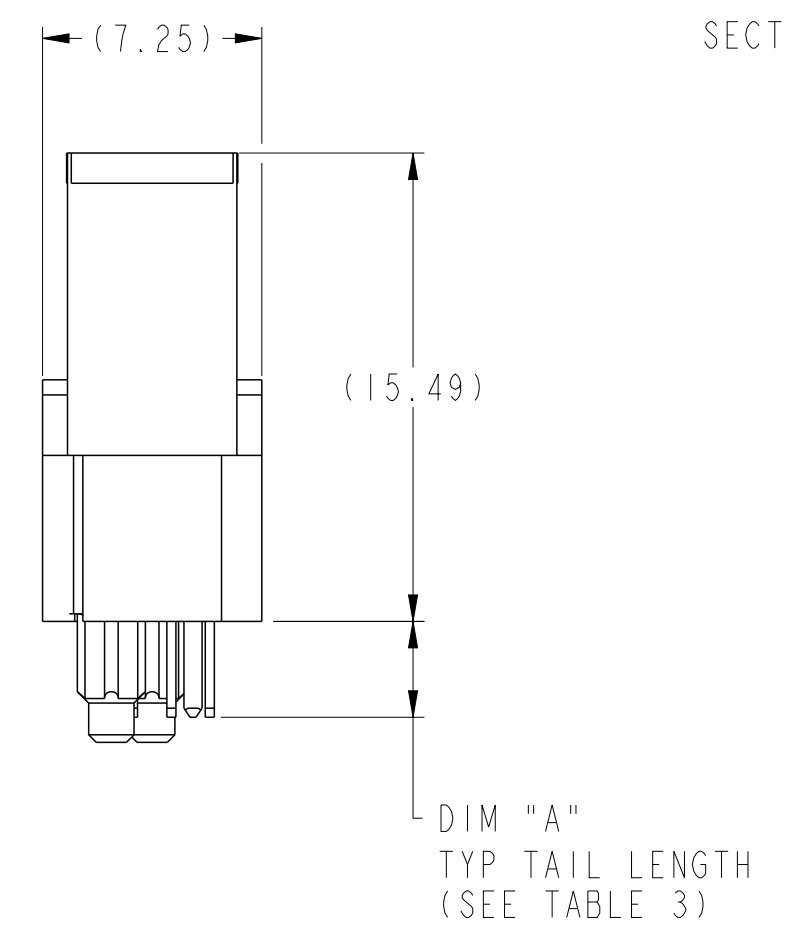
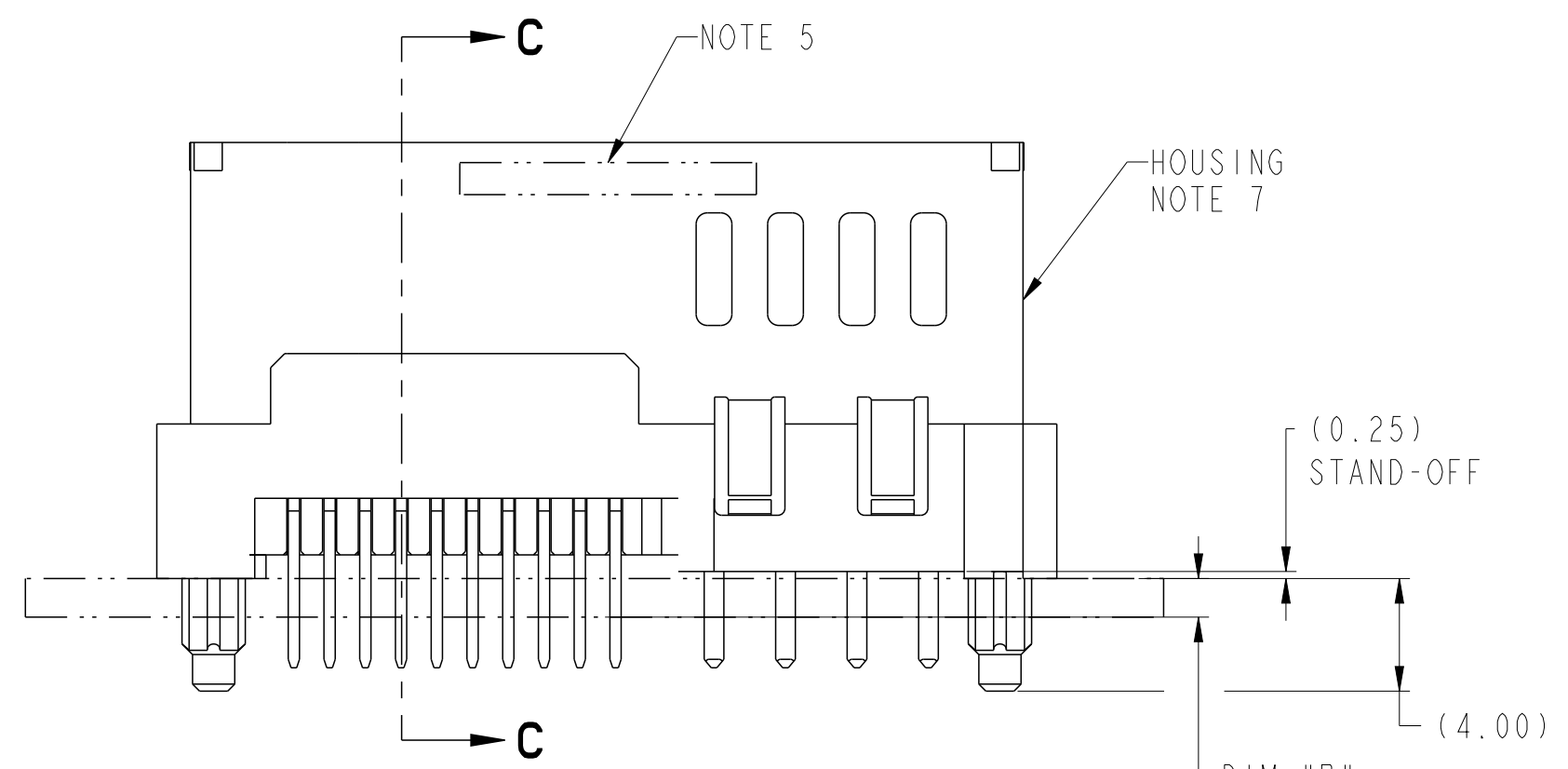
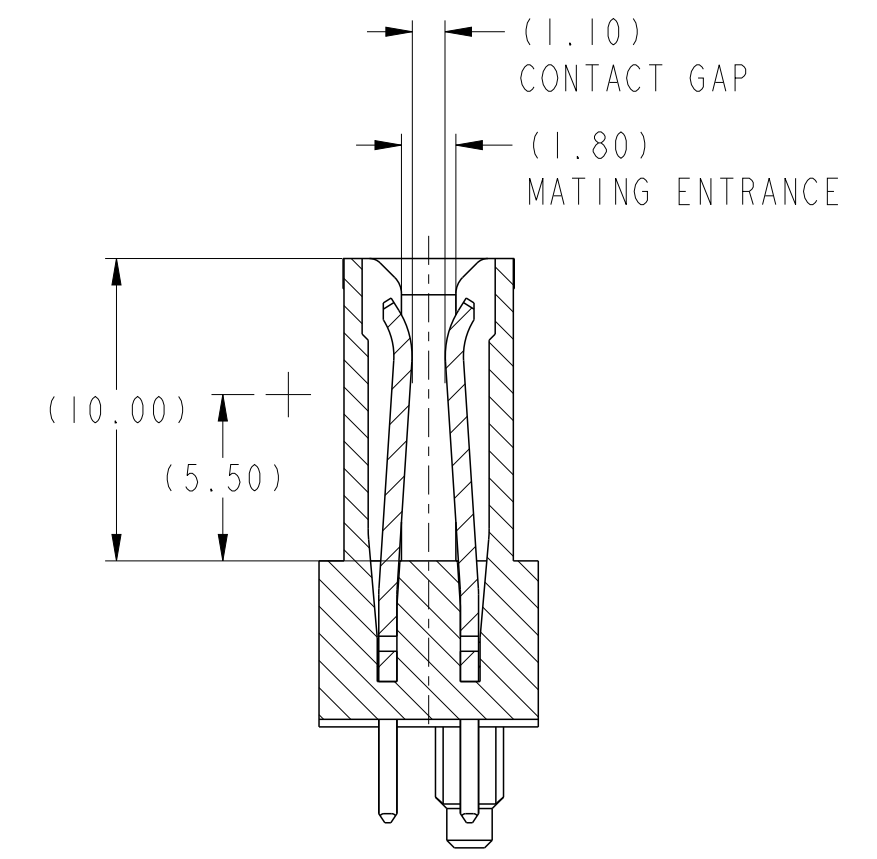
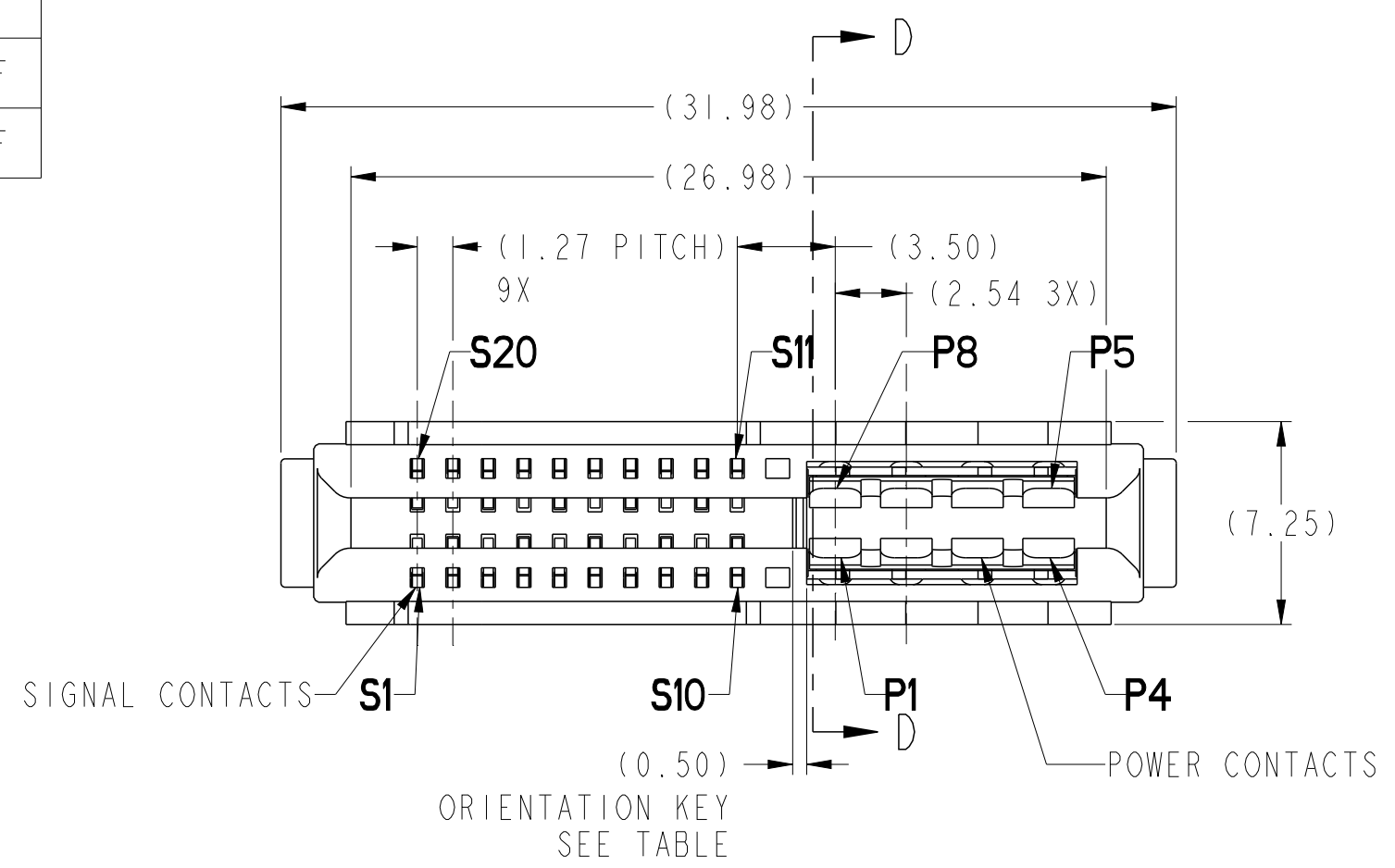

SECTION C-C

spec ref	-	dr	Wei-Long Zhang	2011/11/15	projection	MM	size	A2	scale	4:1	
tolerance std	ASME Y14.5	eng	Sunny2 Liu	2016/05/05			ecn no	ELX-DG-24036-1			
TOLERANCES UNLESS OTHERWISE SPECIFIED		chr	Terris Liu	2016/05/20			rel level	Released			
surface	ASME Y14.5	appr	Pai-Ming Zheng	2016/05/24			product family	HPCE			
linear	0.X ±0.3	Amphenol FCI		title	VERT RECT (20S+8P)			dwg no	10119472		
	0.XX ±0.10				HIGH POWER CARD EDGE			rev	C		
angular	0° ±2°			cat. no.	-			Product - Customer Drw		sheet 1 of 5	

PDS: Rev :C

STATUS:Released

Printed: May 24, 2016

Amphenol FCI

© 2016 APCI

PART NUMBER
10119472-003
10119472-003LF
10119472-004
10119472-004LF

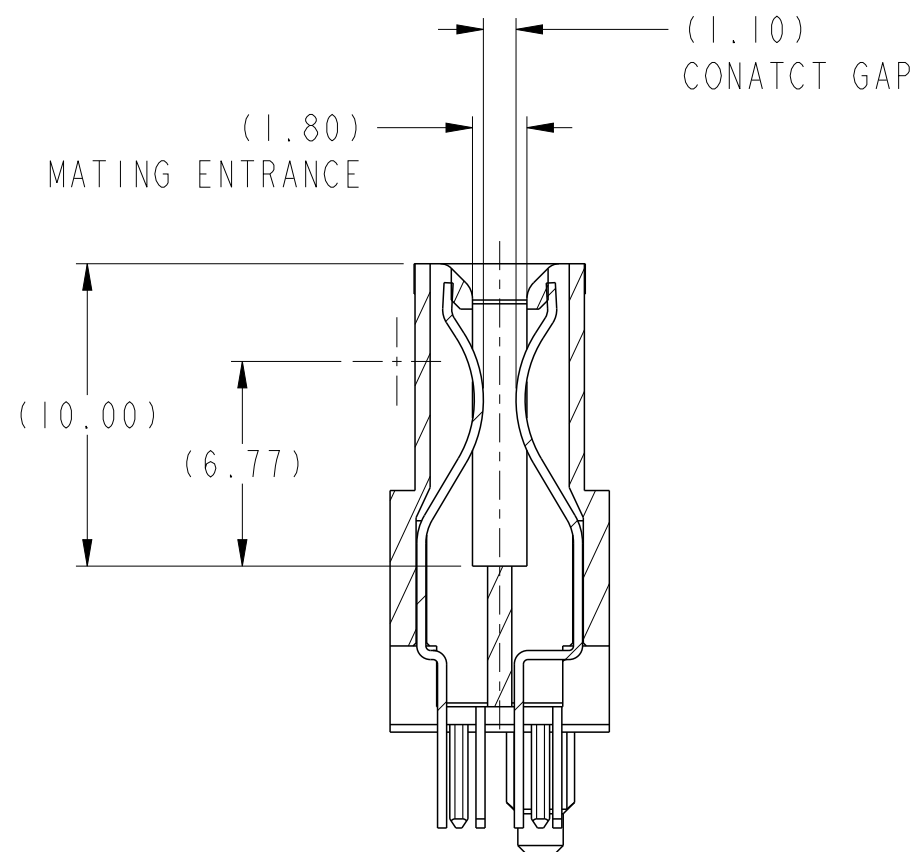
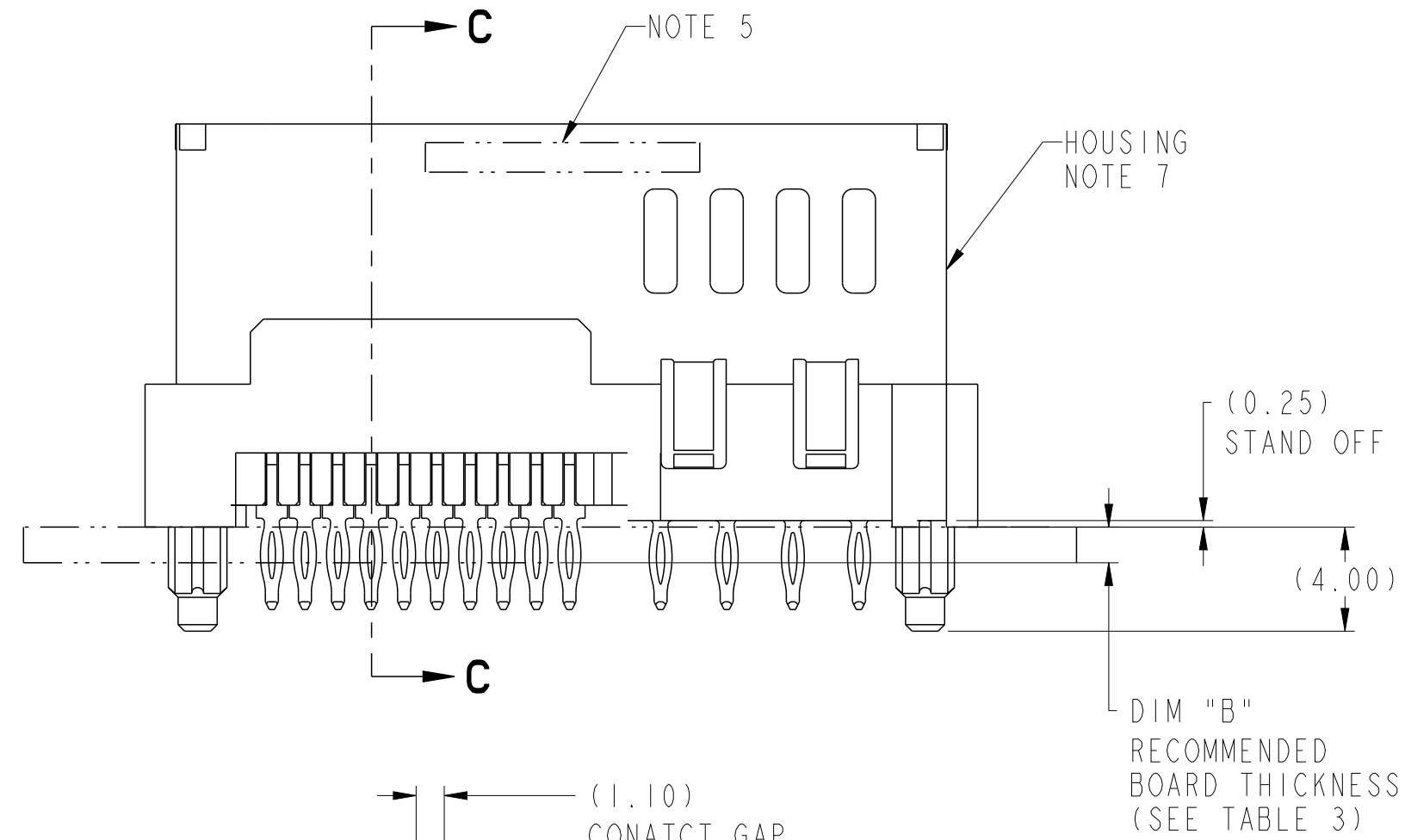
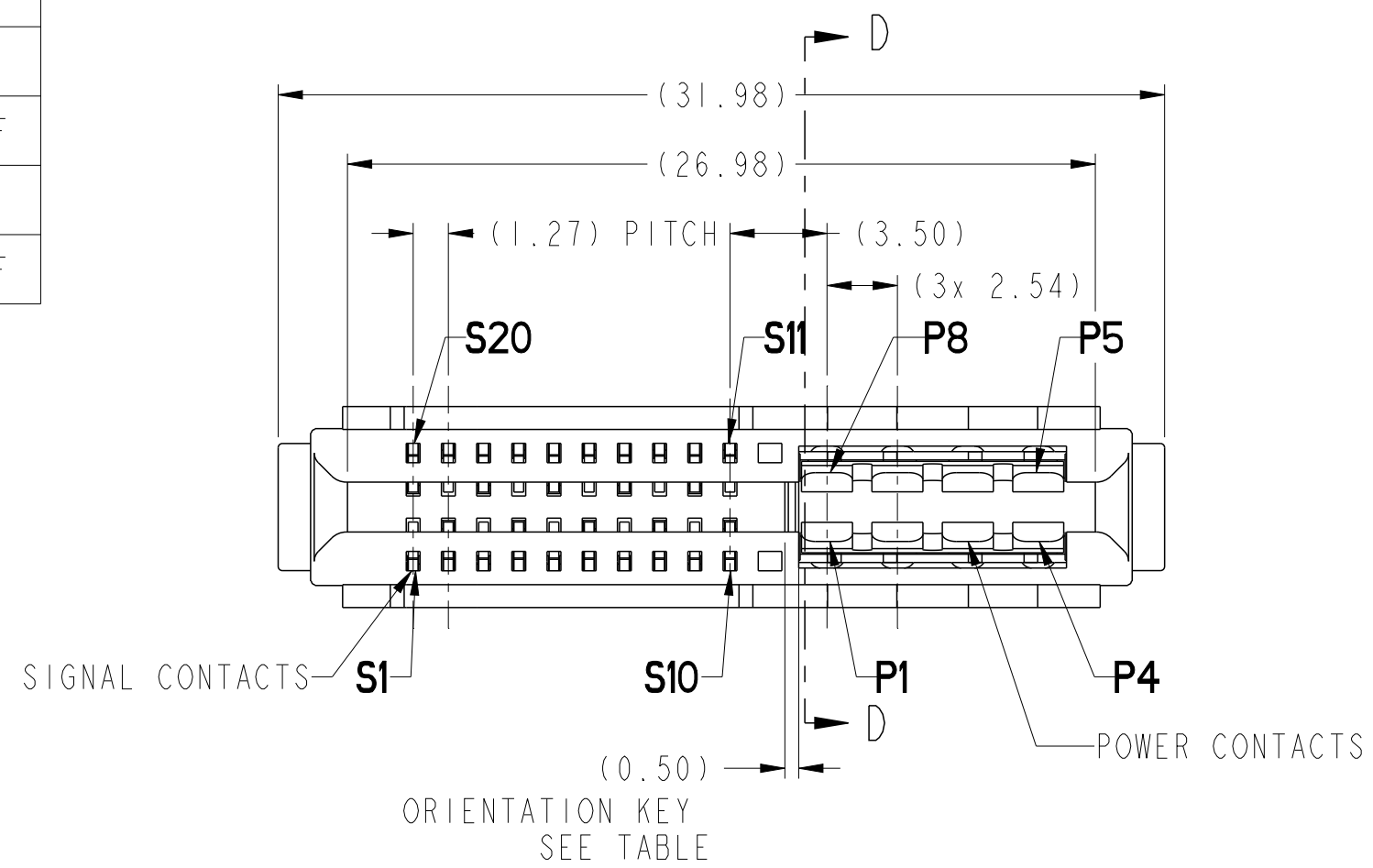

SECTION C-C

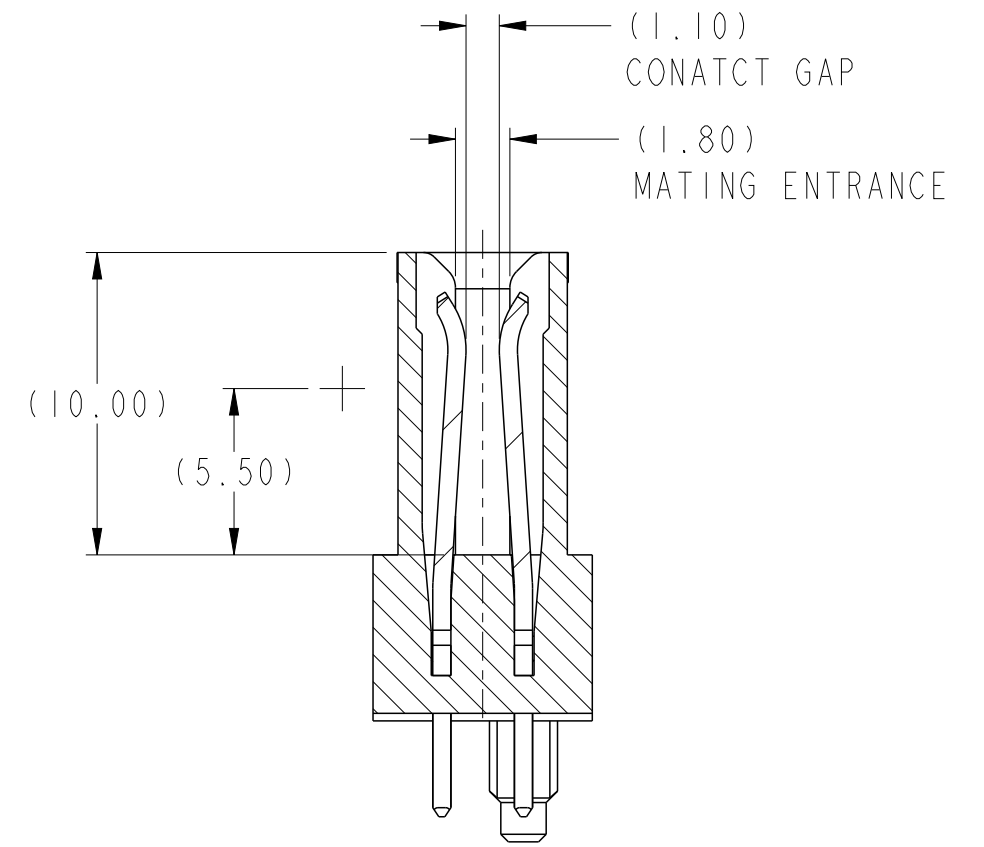

SECTION D-D

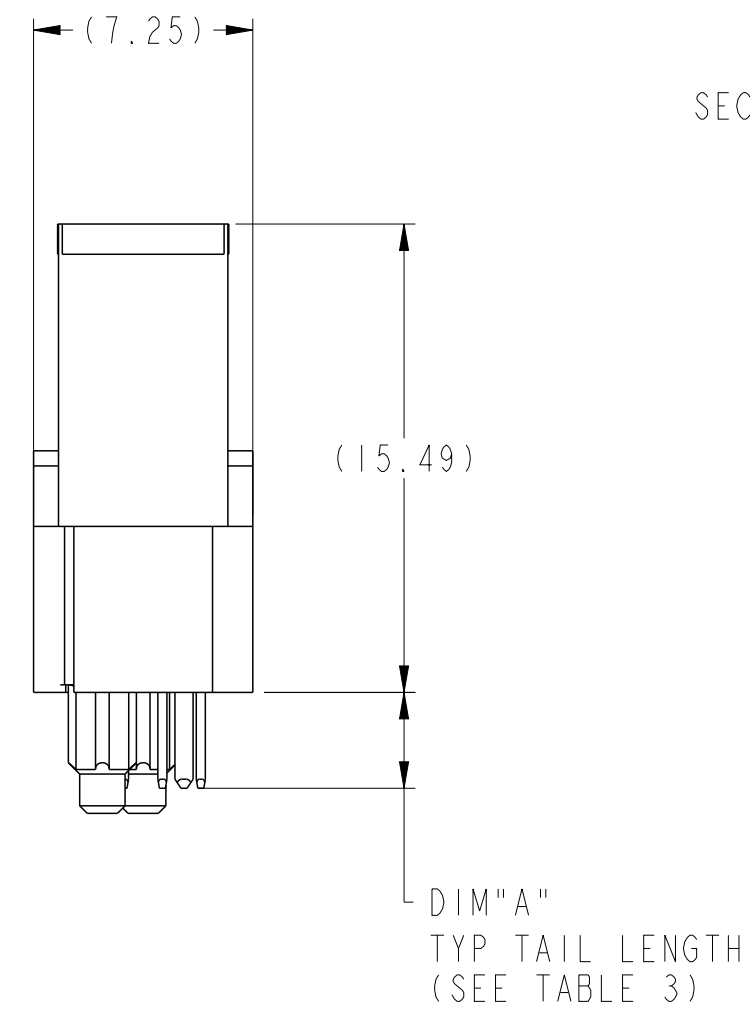

DIM "A"
TYP TAIL LENGTH
(SEE TABLE 3)

spec ref	-	dr	Wei-Long Zhang	2011/11/15	projection	MM	size	A2	scale	4:1	
tolerance std	ASME Y14.5	eng	Sunny2 Liu	2016/05/05			ecn no	ELX-DG-24036-1			
TOLERANCES UNLESS OTHERWISE SPECIFIED		chr	Terris Liu	2016/05/20			rel level	Released			
surface	ASME Y14.5	appr	Pai-Ming Zheng	2016/05/24			product family	HPCE			
linear	0.X ±0.3	Amphenol FCI		title	VERT RECT (20S+8P)			dwg no	10119472		
	0.XX ±0.10				HIGH POWER CARD EDGE			rev	C		
angular	0° ±2°			cat. no.	-			Product - Customer Drw	sheet 2 of 5		

PDS: Rev :C

STATUS:Released

Printed: May 24, 2016

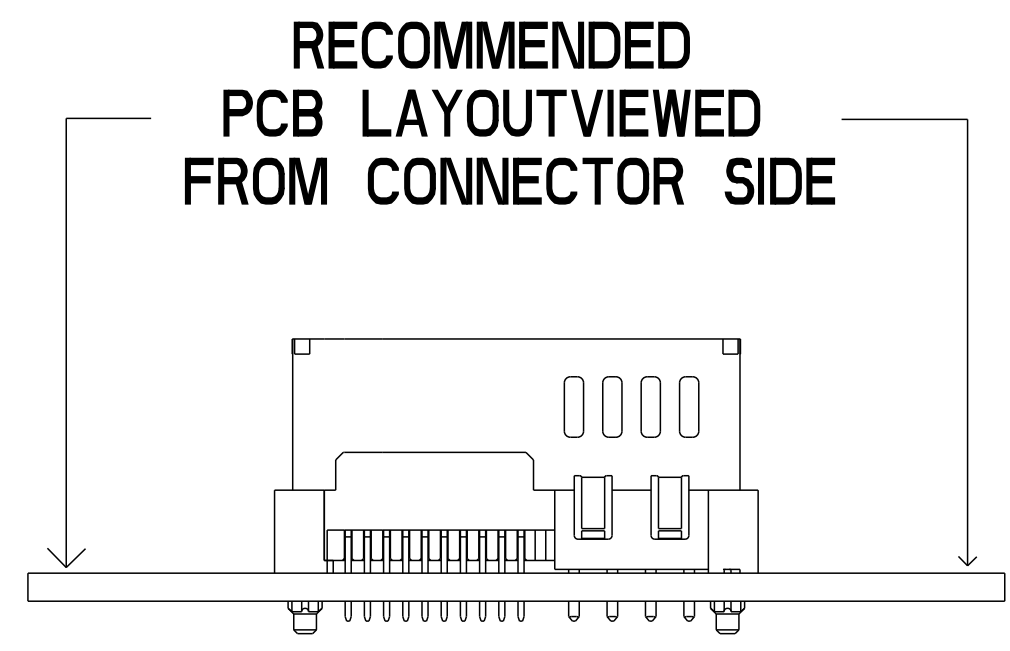
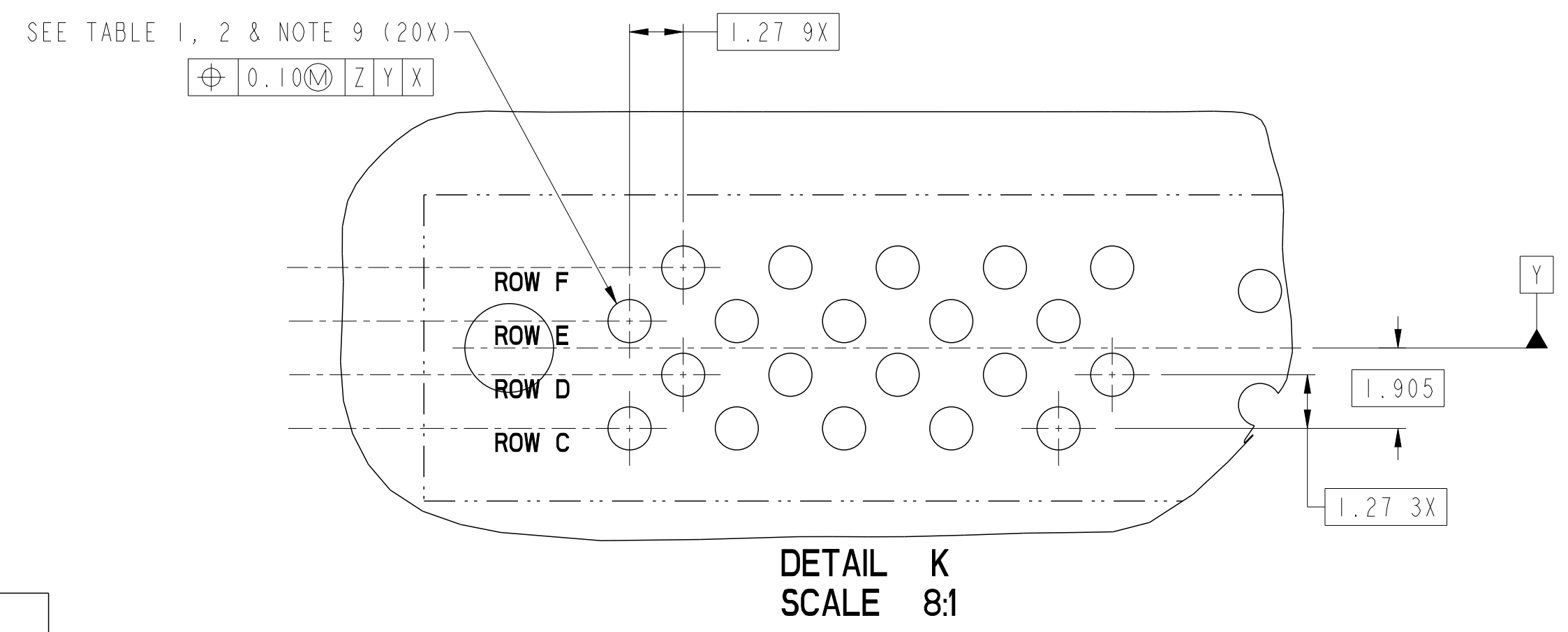
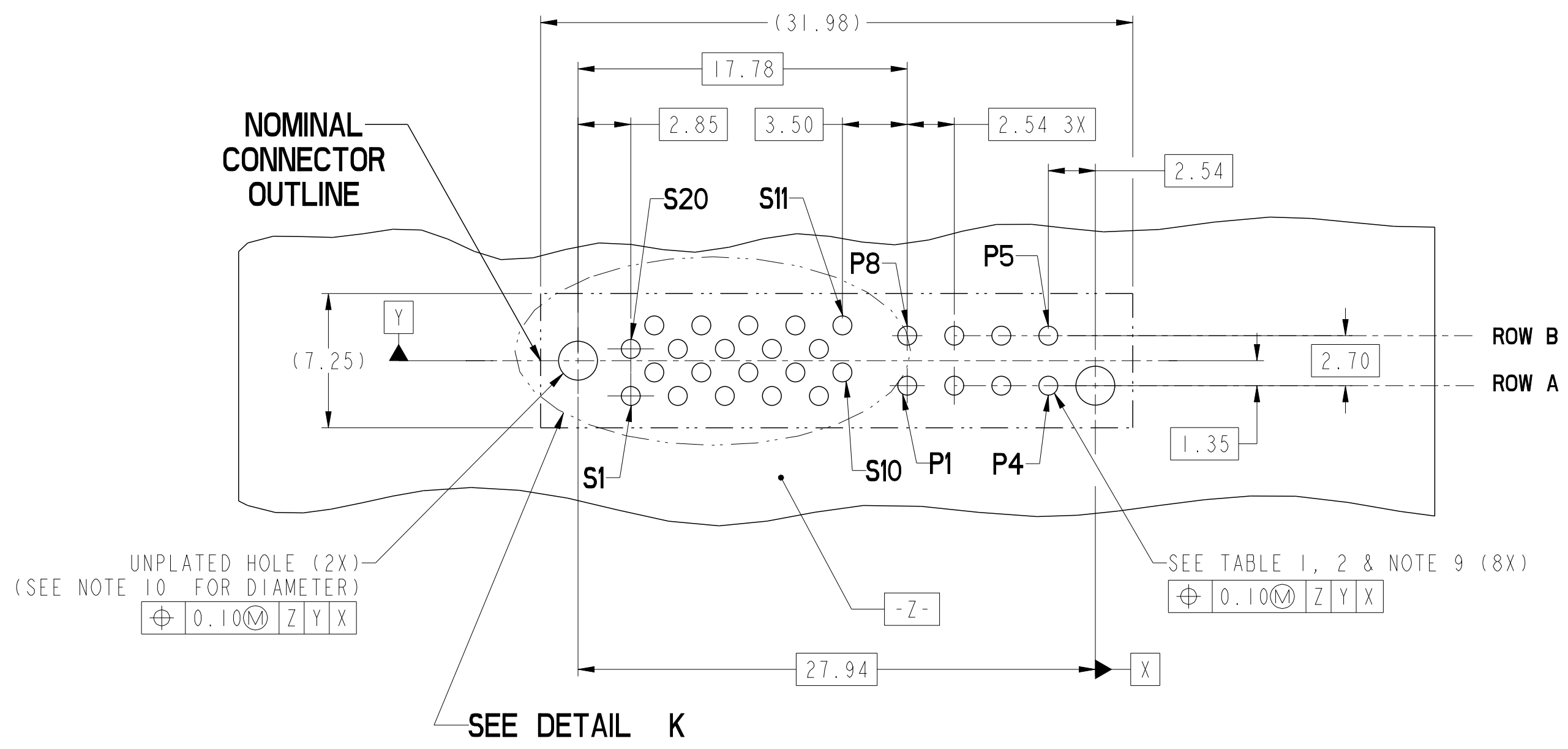

spec ref	-	dr	Wei-Long Zhang	2011/11/15	projection	MM	size	A2	scale	1:1
tolerance std	ASME Y14.5	eng	Sunny2 Liu	2016/05/05			ecn no	ELX-DG-24036-1		
TOLERANCES UNLESS OTHERWISE SPECIFIED		chr	Terris Liu	2016/05/20				rel level	Released	
surface	linear	appr	Pei-Ming Zheng	2016/05/24	product family	-				
ASME Y14.5	angular	Amphenol FCI		title VERT RECT (20S+8P) HIGH POWER CARD EDGE	cat. no. -	Product - Customer Drw	sheet 3 of 5	rev C	10119472	

PDS: Rev :C

STATUS:Released

Printed: May 24, 2016

Amphenol FCI

© 2016 AFCI

CONTACT TYPE	TOP LAYER DESCRIPTION	TABLE 1 (HPCE / SOLDER TAILS) PLATED THROUGH-HOLE REQUIREMENTS				
		DRILLED HOLE DIAMETER	COPPER THICKNESS	TIN-LEAD THICKNESS	TIN THICKNESS	FINISHED HOLE DIAMETER
POWER & SIGNAL	TIN-LEAD	1.10-1.16 (1.15 DRILL)	0.025 - 0.050	0.005 - 0.015	--	0.94 - 1.10
	IMMERSION TIN	1.10-1.16 (1.15 DRILL)	0.025 - 0.050	--	0.9 - 1.5um	0.94 - 1.10
	COPPER (SEE NOTE 8)	1.10-1.16 (1.15 DRILL)	0.025 - 0.050	--	--	0.94 - 1.10

CONTACT TYPE	TOP LAYER DESCRIPTION	TABLE 2 (HPCE / PRESS-FIT TAILS) PLATED THROUGH-HOLE REQUIREMENTS				
		DRILLED HOLE DIAMETER	COPPER THICKNESS	TIN-LEAD THICKNESS	TIN THICKNESS	FINISHED HOLE DIAMETER
POWER & SIGNAL	TIN-LEAD	0.81-0.86 (0.85 DRILL)	0.025 - 0.050	0.005 - 0.015	--	0.65 - 0.80
	IMMERSION TIN	0.81-0.86 (0.85 DRILL)	0.025 - 0.050	--	0.9 - 1.5um	0.70 - 0.80
	COPPER (SEE NOTE 8)	0.81-0.86 (0.85 DRILL)	0.025 - 0.050	--	--	0.70 - 0.80

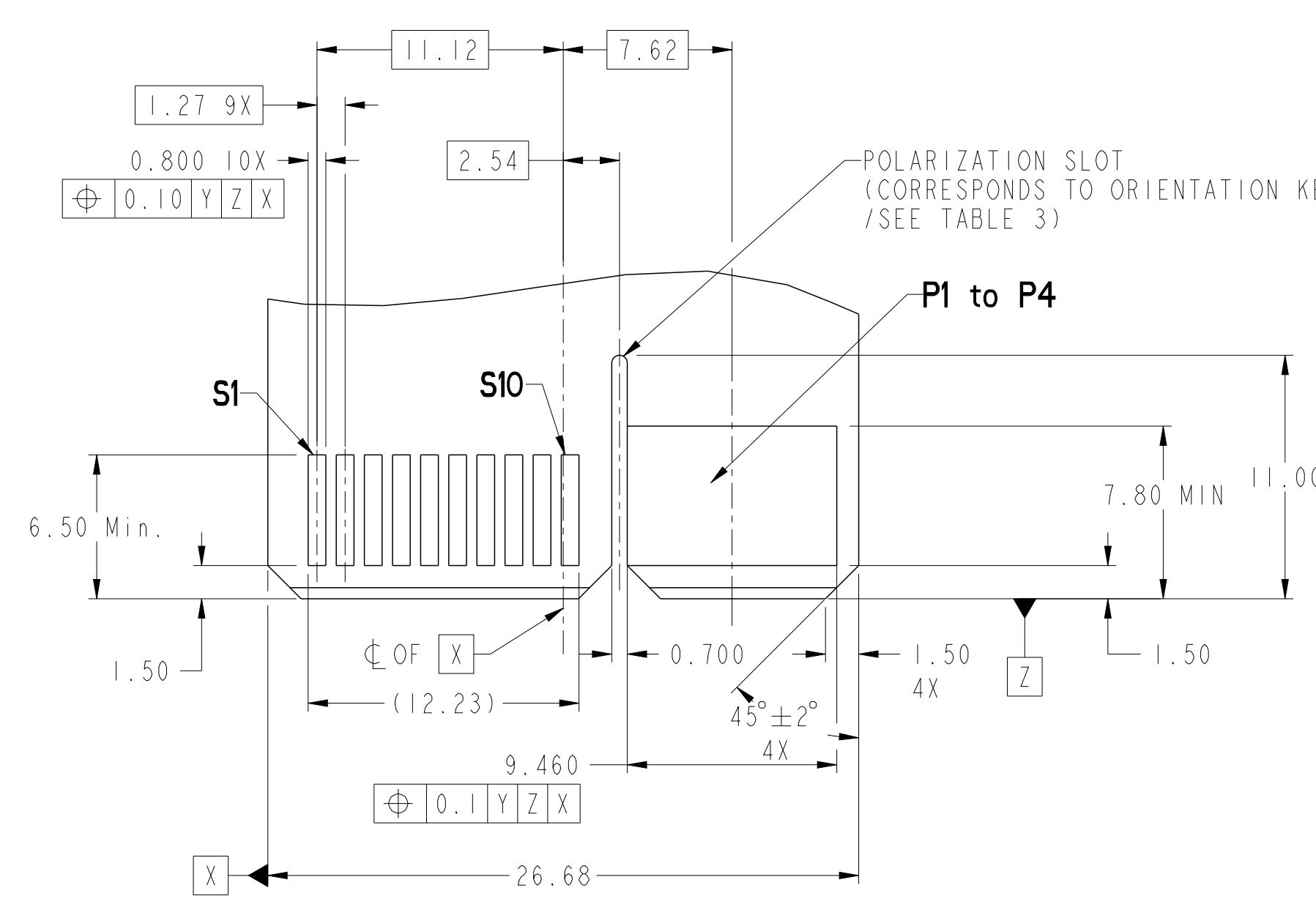

RECOMMENDED MATING BOARD FOOTPRINT

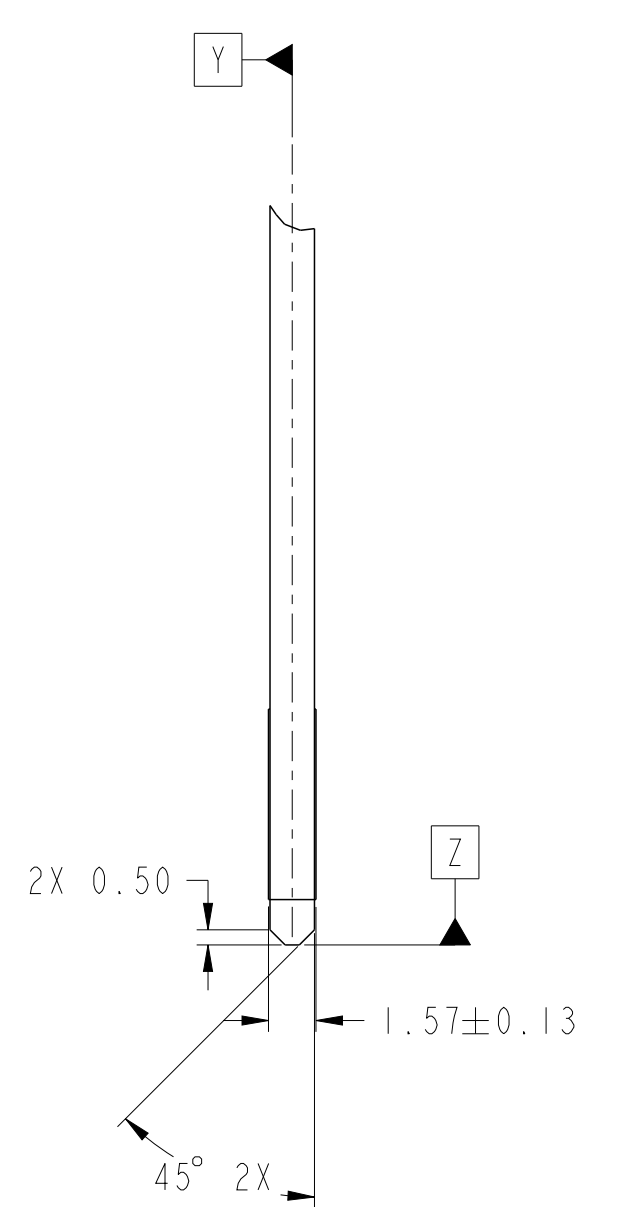

spec ref	-	dr	Wei-Long Zhang	2011/11/15	projection	MM	size	A2	scale	1:1	
tolerance std	ASME Y14.5	eng	Sunny2 Liu	2016/05/05	chr	Terris Liu	2016/05/20	ecn no	ELX-DG-24036-1	rel level	Released
surface	linear	0.X	±0.3	0.XX	±0.10	0.XXX	±0.050	product family	-	cat. no.	-
ASME Y14.5	angular	0°	±2°	Amphenol FCI		VERT RECT (20S+8P) HIGH POWER CARD EDGE		dwg no	10119472	rev	C
Product - Customer Drw											

PDS: Rev :C

STATUS:Released

Printed: May 24, 2016

Amphenol FCI

© 2016 AFCl

HPCE PART NUMBER (TABLE 3)

PART NUMBER	TAIL TYPE	ORIENTATION KEY	DIM "A" TYPICAL TAIL LENGTH	DIM "B" RECOMMENDED BOARD THICKNESS
10119472-001LF	SOLDER	YES	3.17 ±0.25	1.59 - 2.38
10119472-002LF	SOLDER	NO		
10119472-003	PRESS-FIT	YES	3.17 ±0.25	1.57 MIN
10119472-003LF	PRESS-FIT	YES		
10119472-004	PRESS-FIT	NO		
10119472-004LF	PRESS-FIT	NO		

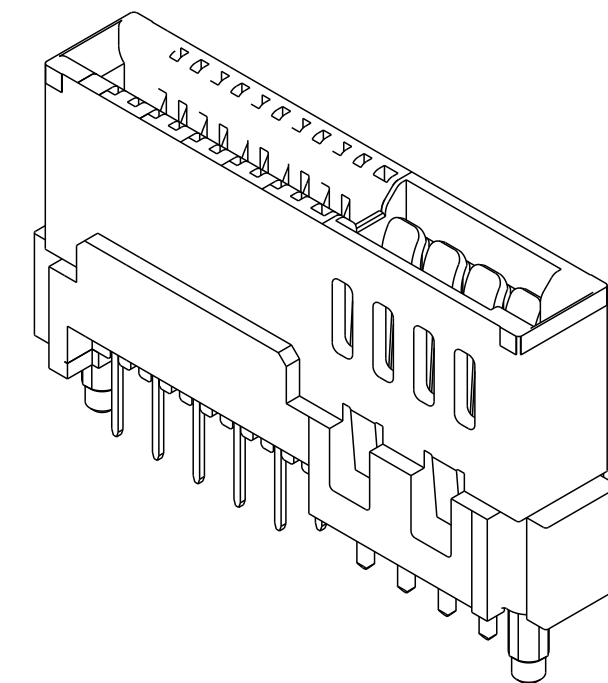

NOTES:

- CONNECTOR MATERIALS:
 HOUSING: HIGH TEMPERATURE THERMAL PLASTIC, BLACK
 UL 94V-0 COMPLIANT
 CONTACTS: HIGH PERFORMANCE COPPER ALLOY.
- CONTACT FINISH REF. GS-12-604 SECTION 5.2.
- PRODUCT SPECIFICATION: GS-12-604.
- APPLICATION SPECIFICATION: GS-20-128.
- PRODUCT MARKING ON HOUSING IN AREA SHOWN MEETS AFCI SPECIFICATION: GS-24-007.
- PACKAGING MEETS FCI SPECIFICATION GS-14-937.
- HOUSING COMPONENT WILL WITHSTAND EXPOSURE TO 260°C PEAK TEMPERATURE FOR 60 SECONDS IN A CONVECTION, INFRA-RED, OR VAPOR PHASE REFLOW OVEN.
- COPPER PLATING THICKNESS IN CENTER OF VIA-HOLE CAN BE NO MORE THAN 0.003 LESS THAN OTHER AREAS.
- ALL HOLE SIZES ARE FINISHED HOLE SIZES.
- MOUNTING HOLES ARE UNPLATED
 ∅ 2.40 +/- 0.1 FOR PRESS-FIT TAILS
 ∅ 2.18 +/- 0.03 FOR SOLDER TAILS

11. SYMBOL WILL BE NEXT TO ANY DIMENSION, VIEW, OR NOTE WHICH HAS BEEN MODIFIED WITH THE CURRENT DRAWING REVISION.

spec ref	-	dr	Wei-Long Zhang	2011/11/15	projection	MM	size	A2	scale	4:1
tolerance std	ASME Y14.5	eng	Sunny2 Liu	2016/05/05			ecn no	ELX-DG-24036-1	rel level	Released
TOLERANCES UNLESS OTHERWISE SPECIFIED		chr	Terris Liu	2016/05/20						
TOLERANCES UNLESS OTHERWISE SPECIFIED		appr	Pai-Ming Zheng	2016/05/24						
surface	linear	0.X	±0.3		product family HPCE	title VERT RECT (20S+8P) HIGH POWER CARD EDGE	dwg no 10119472	rev C	cat. no.	Product - Customer Drw
	linear	0.XX	±0.10							
	linear	0.XXX	±0.050							
	angular	0°	±2°	sheet 5 of 5						

Amphenol FCI

© 2016 AFCI