

THIS DRAWING IS UNPUBLISHED. RELEASED FOR PUBLICATION
 © COPYRIGHT - By - ALL RIGHTS RESERVED.

LOC		DIST		REVISIONS			
P	LTR	DESCRIPTION		DATE	DWN	APVD	
AG	00	G3	REVISED PER ECO-13-007818	09MAY2013	KH	AS	

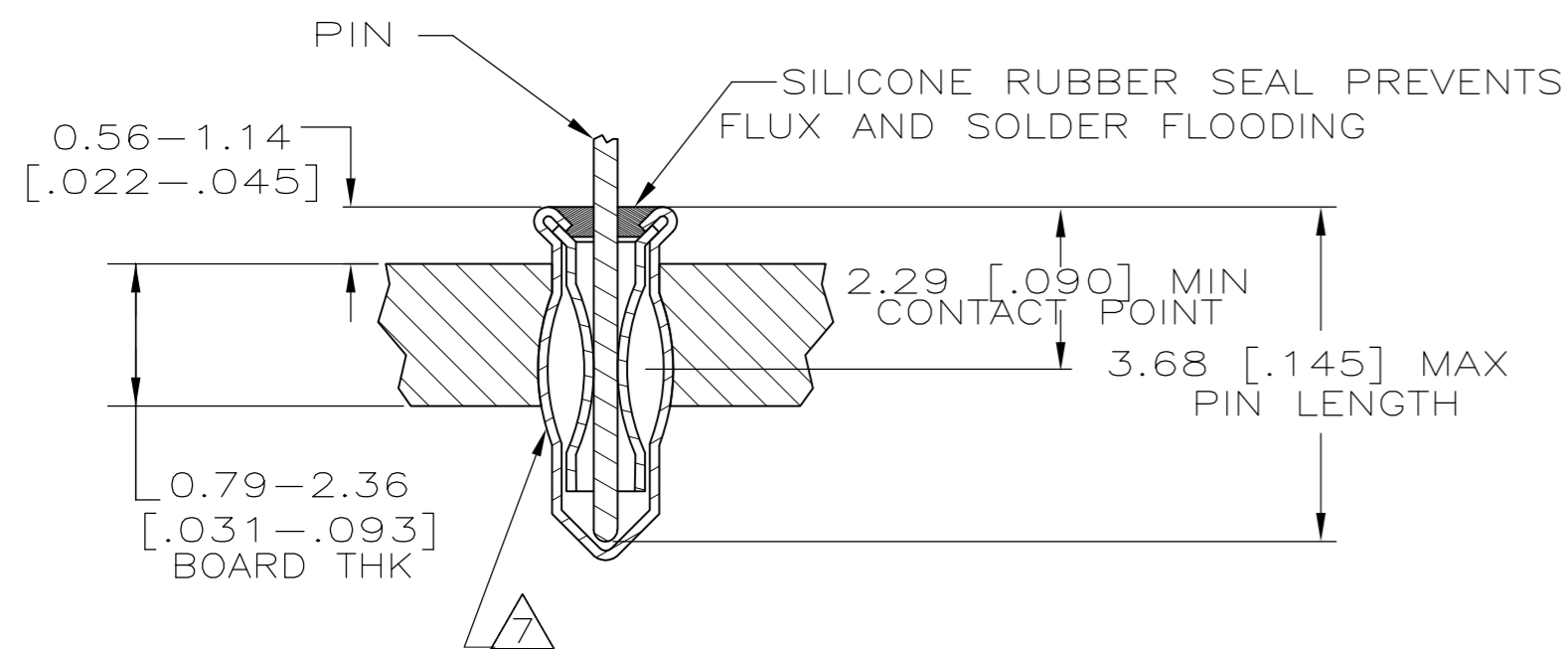
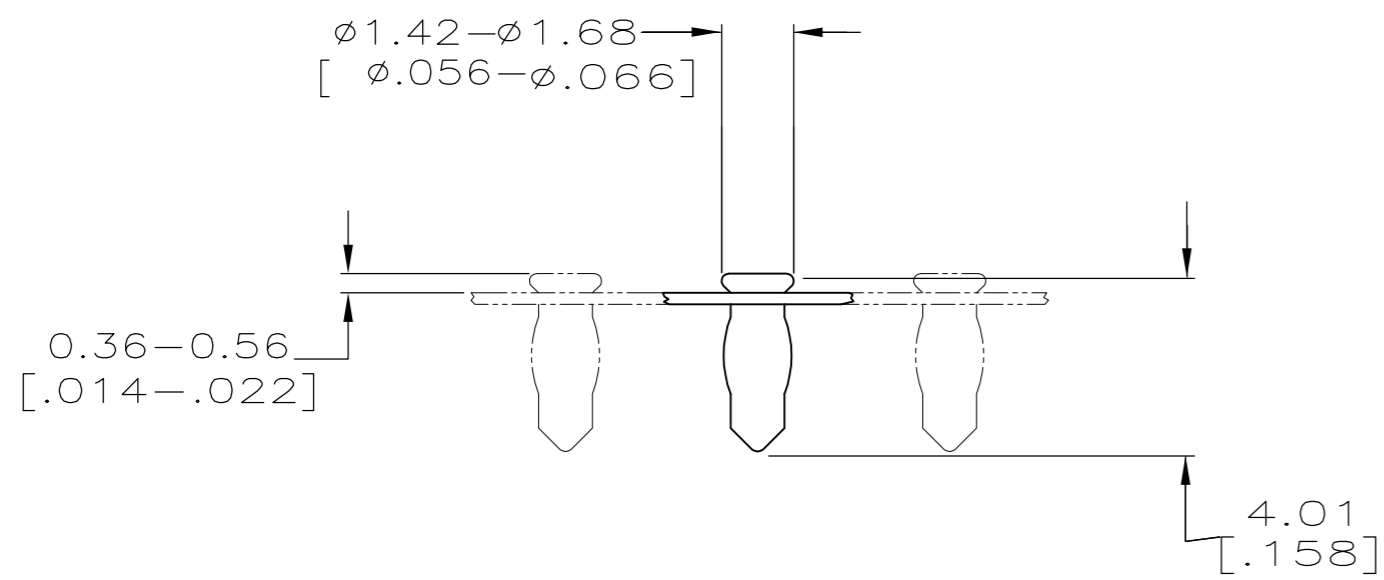
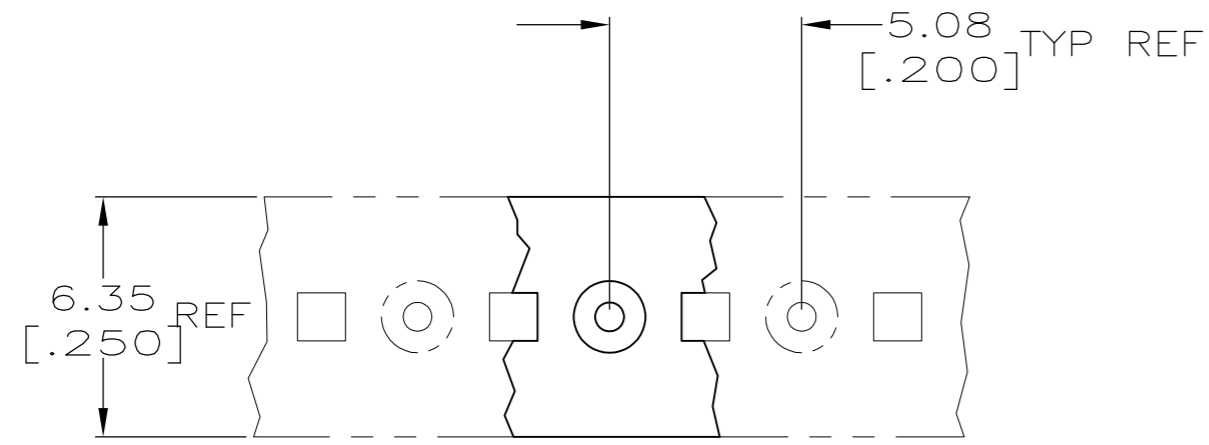

- 1 MATERIAL:
EYELET - COPPER (QQ-C-576)
SPRING - BERYLLIUM COPPER (QQ-C-533)
SEALANT - SILICONE RUBBER
- 2 TIN PLATE (MIL-T-10727)0.00381 [.000150] MIN THK.
- 3 TIN PLATE(MIL-T-10727)0.00254 [.000100] MIN THK.
- 4 GOLD PL(MIL-G-45204)0.00076 [.000030] MIN THK ON CONTACT AREA.
- 5 PACKAGED 50,000 PER REEL
- 6 TO INSURE 1/2 OZ MIN RETENTION DO NOT EXCEED 0.10 [.004] DIFFERENCE IN PIN DIA WHEN CHANGING TO A SMALLER DIA PIN
- 7 PRODUCT IS OVALIZED FOR RETENTION IN THE P.C. BOARD. THE RECOMMENDED HOLE DIAMETER IS $\phi 1.07$ [$\phi .042$] MINIMUM, +0.08 [.003] MAX. PRIOR TO SOLDERING.
- 8 TIN-LEAD PLATE 0.00381 [.000150] MIN THK.
- 9 PACKAGED 10,000 PER REEL

OBSOLETE	2.29-3.68 [.090-.145]	$\phi 0.38-\phi 0.53$ [$\phi .015-\phi .021$]	GOLD 4	TIN 2	5	1-645947-7
OBSOLETE	2.29-3.68 [.090-.145]	$\phi 0.38-\phi 0.53$ [$\phi .015-\phi .021$]	GOLD 4	TIN 8	9	1-645947-6
OBSOLETE	2.29-3.68 [.090-.145]	$\phi 0.30-\phi 0.46$ [$\phi .012-\phi .018$]	GOLD 4	TIN 2	9	1-645947-5
OBSOLETE	2.29-3.68 [.090-.145]	$\phi 0.30-\phi 0.46$ [$\phi .012-\phi .018$]	TIN 3	TIN 2	9	1-645947-4
OBSOLETE	2.29-3.68 [.090-.145]	$\phi 0.38-\phi 0.53$ [$\phi .015-\phi .021$]	GOLD 4	TIN 2	9	1-645947-2
OBSOLETE	2.29-3.68 [.090-.145]	$\phi 0.38-\phi 0.53$ [$\phi .015-\phi .021$]	TIN 3	TIN 2		1-645947-1
OBSOLETE	2.29-3.68 [.090-.145]	$\phi 0.38-\phi 0.53$ [$\phi .015-\phi .021$]	GOLD 4	TIN 2	5	645947-2
SUPERSEDED BY 5645947-1	2.29-3.68 [.090-.145]	$\phi 0.38-\phi 0.53$ [$\phi .015-\phi .021$]	TIN 3	TIN 2	5	645947-1
	LENGTH	DIA	FINISH			PART NO
			SPRING	EYELET		

THIS DRAWING IS A CONTROLLED DOCUMENT.

DIMENSIONS: mm [INCHES]	TOLERANCES UNLESS OTHERWISE SPECIFIED: 0 PLC ± - 1 PLC ± - 2 PLC ± - 3 PLC ± 0.20[.008] 4 PLC ± - ANGLES ± -	DWN M.BOWERS 12-20-82 CHK P.MUTZABAUGH 6-10-85 APVD G.MILLER 6-10-85 PRODUCT SPEC APPLICATION SPEC 114-26004	NAME STE TE Connectivity MINIATURE SPRING SOCKET ASSY SERIES 1 SHORT WITH SEALANT
MATERIAL 1	FINISH SEE TABLE	WEIGHT - CUSTOMER DRAWING	SIZE A2 CAGE CODE 00779 DRAWING NO C-645947 RESTRICTED TO - SCALE NTS SHEET 1 OF 1 REV G3