

Evaluation Board for **ADP1031** Three-Channel, Isolated Micropower Management Unit with Seven Digital Isolators

FEATURES

- Input voltage range: 4.5 V to 60 V
- Output voltage V_{OUT1} : 24 V or 21 V
- Output voltage V_{OUT2} : 5.15 V
- Output voltage V_{OUT3} : -15 V
- Enable and disable controls
- Slew rate controls
- Access to SYNC pin for oscillator synchronization
- Access to all seven data channels

EVALUATION KIT CONTENTS

[ADP1031CP-1-EVALZ](#), [ADP1031CP-2-EVALZ](#), [ADP1031CP-3-EVALZ](#), [ADP1031CP-4-EVALZ](#), or [ADP1031CP-5-EVALZ](#) evaluation board

SUPPORTED **ADP1031** GENERICS

[ADP1031ACPZ-1](#), [ADP1031ACPZ-2](#), [ADP1031ACPZ-3](#), [ADP1031ACPZ-4](#), and [ADP1031ACPZ-5](#)

EQUIPMENT NEEDED

- DC power supplies
- Multimeters for voltage and current measurements
- Electronic load or resistive loads
- Function generator or alternative digital driver
- Oscilloscope

DOCUMENTS NEEDED

[ADP1031](#) data sheet

GENERAL DESCRIPTION

The ADP1031CP-EVALZ is a fully featured evaluation board that demonstrates the functionality of the [ADP1031](#) dc-to-dc converters and the isolated data channels.

Users can evaluate [ADP1031](#) device measurements, such as line regulation, load regulation, and efficiency with the evaluation board. The board also assists in evaluating the functionality of the isolated digital channels. Device features including oscillator synchronization, soft start, power good monitoring, sequencing, and slew rate control can be demonstrated on the evaluation board.

Each board model in the evaluation kit has a different output configuration. Only one board model is included in the kit but users can order from five different board models to fit their application needs.

Refer to the [ADP1031](#) data sheet for more details about the dc-to-dc converters and isolated data channels.

EVALUATION BOARD PHOTOGRAPH

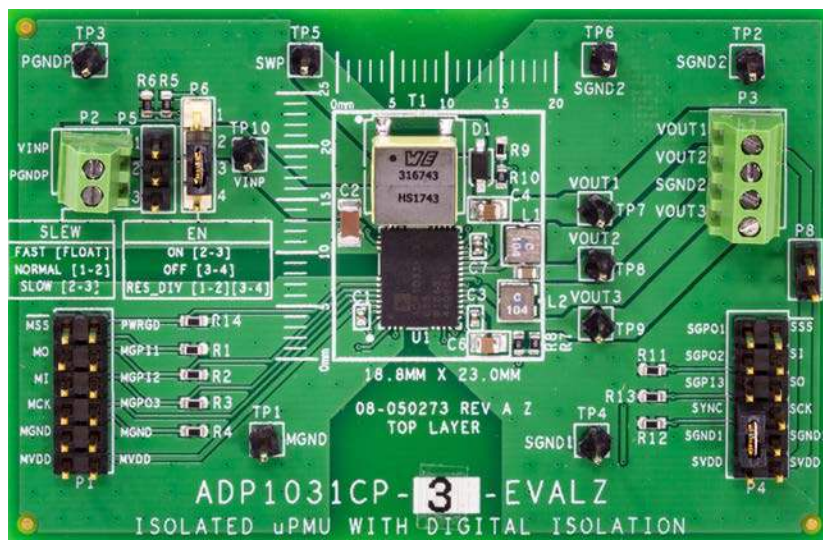

Figure 1.

TABLE OF CONTENTS

Features	1	Power Domain Efficiency Measurement	6
Evaluation Kit Contents.....	1	Data Input/Output (I/O) Measurement.....	7
Supported ADP1031 Generics.....	1	High Voltage Capability	7
Equipment Needed.....	1	Output Voltage Measurements	8
Documents Needed.....	1	Line Regulation.....	8
General Description	1	Load Regulation	8
Evaluation Board Photograph.....	1	Efficiency	9
Revision History	2	Evaluation Board Schematics and Artwork.....	10
Evaluation Board Hardware	3	Ordering Information.....	14
Evaluation Board Configurations	3	Bill of Materials.....	14
Measurement Setup.....	6		
Regulator Output Measurement.....	6		

REVISION HISTORY

1/2019—Revision 0: Initial Version

EVALUATION BOARD HARDWARE

EVALUATION BOARD CONFIGURATIONS

The evaluation board is preconfigured to the output voltages described in Table 1.

Table 1. Evaluation Board Output Voltage Configurations

Model	V _{OUT1} ¹	V _{OUT2}	V _{OUT3} ¹
ADP1031CP-1-EVALZ	24 V (ADJ)	5.15 V	-15 V (ADJ)
ADP1031CP-2-EVALZ	24 V (ADJ)	5 V	-15 V (ADJ)
ADP1031CP-3-EVALZ	24 V (ADJ)	3.3 V	-15 V (ADJ)
ADP1031CP-4-EVALZ	24 V	5.15 V	-15 V (ADJ)
ADP1031CP-5-EVALZ	21 V	5.15 V	-15 V (ADJ)

¹ ADJ means that the output is adjusted to the specified voltage. If only the voltage is specified, without the ADJ, the output is fixed or factory programmed.

The board is designed so that if desired, the user can customize the converter design to obtain up to 60 V between the VOUT1 and VOUT3 terminals on the board. The user is responsible for ensuring that the board is suitably configured and that appropriate safety precautions are taken.

Figure 2 outlines the evaluation board features available for the user. Figure 3 provides information about both the ADP1031 and locations for optional components, which the user can use to modify the converter design.

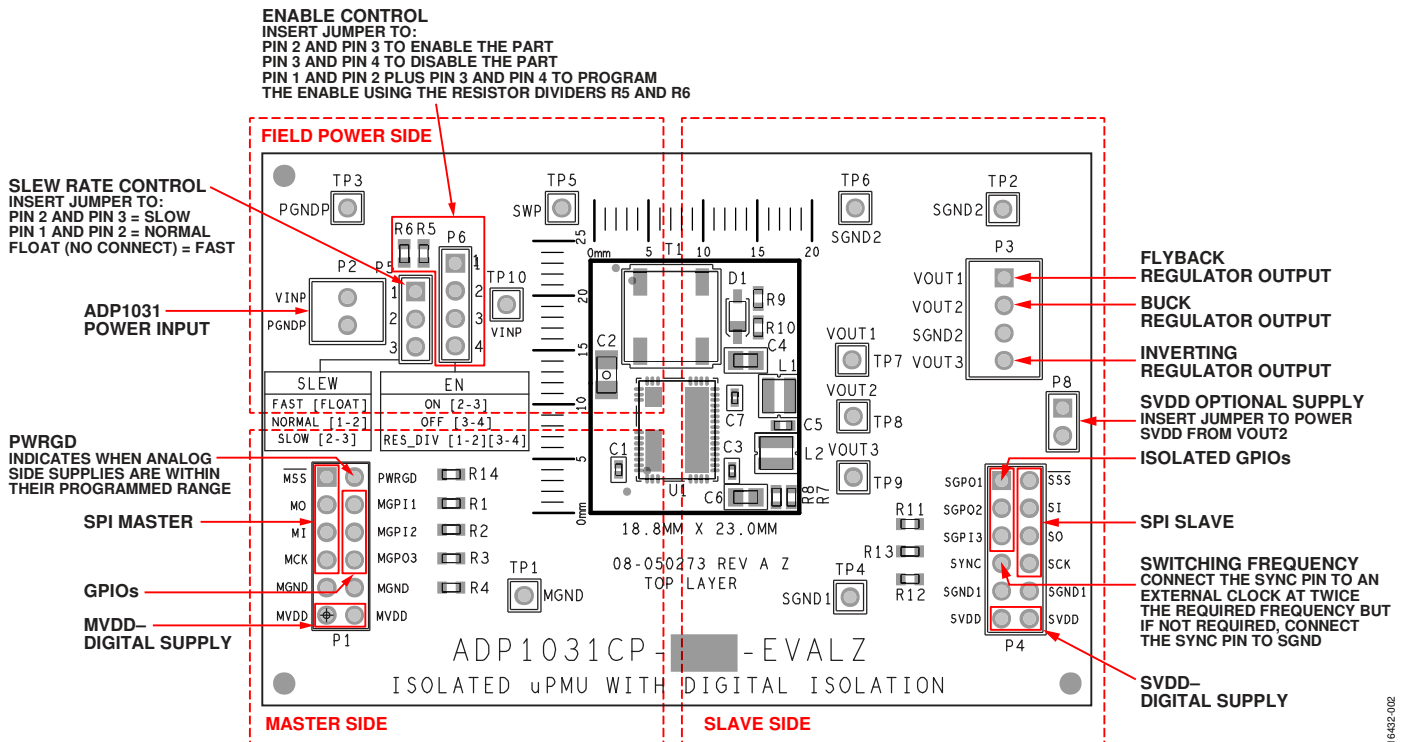

Figure 2. Outline of ADP1031CP-EVALZ Evaluation Board Features

16432-002

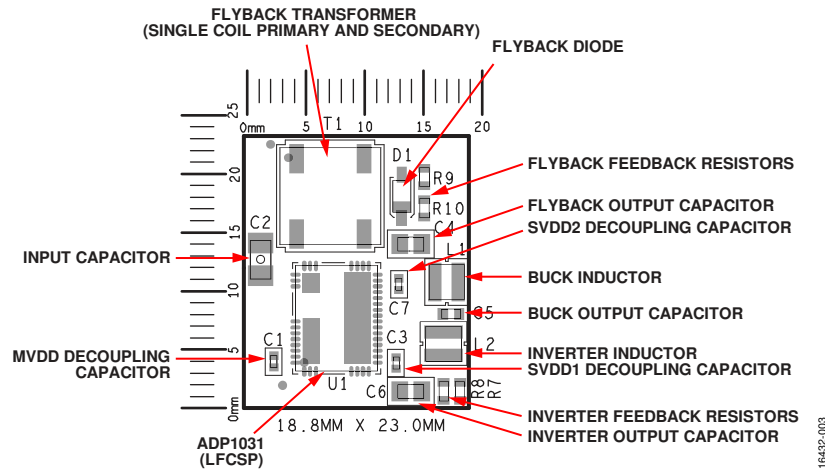

Figure 3. ADP1031CP-EVALZ Top Component Detail

Table 2. Evaluation Board Function Descriptions

Jumper/Connector Designation	Jumper/Connector Mnemonic	Description
P1	MVDD MCK MI MO MSS PWRGD MGPI1 MGPI2 MGPO3	Master side power input. The input voltage is between 2.3 V and 5.5 V. SPI clock input from the master controller. Drives SCK on the slave side. SPI data output from the slave MI/SO line. Driven by SO on the slave side. SPI data input to the slave MO/SI line. Drives SI on the slave side. SPI slave select input from the master controller. This signal uses an active low logic. Drives SSS on the slave side. Power good. Indicates when secondary side supplies are within the programmed range. General purpose Input 1. Paired with SGPO1. General purpose Input 2. Paired with SGPO2. General purpose Output 3. Paired with SGPI3.
P2	VINP	Power input to the ADP1031 flyback regulator. The input voltage is between 4.5 V and 60 V.
P3	VOUT1 VOUT2 VOUT3	Output from the flyback regulator. Set to 24 V in default configuration. Output from the buck regulator. Factory set to 5.15 V in default configuration. Output from the inverting regulator. Set to -15 V in default configuration.
P4	SVDD SCK SO SI SSS SGPO1 SGPO2 SGPI3 SYNC	Slave side power input. This is between 1.8 V and 5.5 V. SPI clock output from the master MCK/SCK line. Paired with MCK. Driven by MCK on the master side. SPI data input to the master MI/SO line. Paired with MI. Drives MI on the master side. SPI data output from the master MO/SI line. Paired with MO. Driven by MO on the master side. SPI slave select output. Paired with MSS. Driven by MSS on the master side. General purpose Output 1. Paired with MGPI1. General purpose Output 2. Paired with MGPI2. General purpose Input 3. Paired with MGPO3. Frequency setting and synchronization input. Connect the SYNC pin to an external clock with a frequency between 350 kHz and 750 kHz. The switching frequency of the flyback regulator is half of the external clock frequency. If SYNC is not used, connect to SGND.
P5	SLEW	Flyback regulator slew rate control. The SLEW pin sets the slew rate for the SWP driver. For the fastest slew rate (best efficiency), leave the SLEW pin open. For the normal slew rate, connect the SLEW pin to VINP with Pin 1 and Pin 2 shorted. For the slowest slew rate (best electromagnetic interference (EMI) performance), connect the SLEW pin to GNDD with Pin 2 and Pin 3 shorted.
P6	EN	Precision enable control. The EN pin is compared to an internal precision reference to enable the flyback regulator output. Connect a jumper to Pin 2 and Pin 3 to turn on the flyback regulator. Connect a jumper to Pin 3 and Pin 4 to turn off the flyback regulator. Connect a jumper to Pin 1 and Pin 2 together with another jumper to Pin 3 and Pin 4 to use the input as a programmable undervoltage lockout (UVLO) through the R5 resistive divider and R6 resistive divider.

Jumper/Connector Designation	Jumper/Connector Mnemonic	Description
P8	SVDD Optional Supply	Option for VOUT2 to power SVDD. Connect a jumper to P8 to power the SVDD from VOUT2.
TP1	MGND	MGND test point.
TP2, TP6	SGND2	SGND2 test points. Connected to SGND1.
TP3	PGNDP	PGNDP test point.
TP4	SGND1	SGND1 test point. Connected to SGND2.
TP5	SWP	Flyback regulator switching node test point.
TP7	VOUT1	VOUT1 test point.
TP8	VOUT2	VOUT2 test point.
TP9	VOUT3	VOUT3 test point.

MEASUREMENT SETUP

REGULATOR OUTPUT MEASUREMENT

Figure 4 shows the recommended measurement setup to evaluate the ADP1031CP-EVALZ flyback regulator.

Figure 5 shows the recommended setup to evaluate the ADP1031CP-EVALZ buck regulator.

Figure 6 shows the recommended setup to evaluate the ADP1031CP-EVALZ inverting regulator.

POWER DOMAIN EFFICIENCY MEASUREMENT

Measure the actual input voltage and output voltage from the evaluation board for overall efficiency measurements. Figure 7 shows the recommended setup for the overall efficiency measurement for the ADP1031CP-EVALZ.

The overall efficiency is calculated using the following equation:

$$\eta_{OVERALL} = \frac{\left((V_{OUT1} \times I_{OUT1}) + (V_{OUT2} \times I_{OUT2}) + (V_{OUT3} \times I_{OUT3}) \right)}{(V_{INP} \times I_{IN})}$$

where:

$\eta_{OVERALL}$ = the overall efficiency of the ADP1031.

V_{OUT1} = the output voltage of the flyback regulator.

I_{OUT1} = the output current on the flyback regulator.

V_{OUT2} = the output voltage of the buck regulator.

I_{OUT2} = the output current on the buck regulator.

V_{OUT3} = the output voltage of the inverting regulator.

I_{OUT3} = the output current on the inverting regulator.

V_{INP} = the input supply voltage.

I_{IN} = the input supply current.

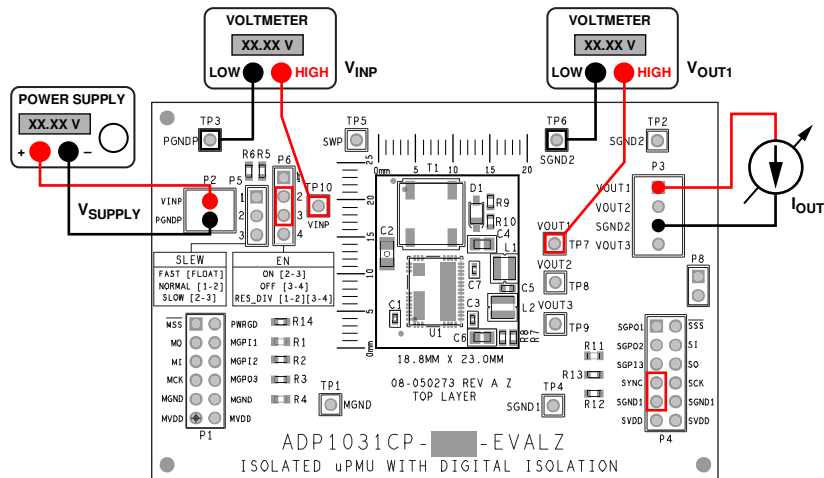

Figure 4. Flyback Regulator Measurement Setup

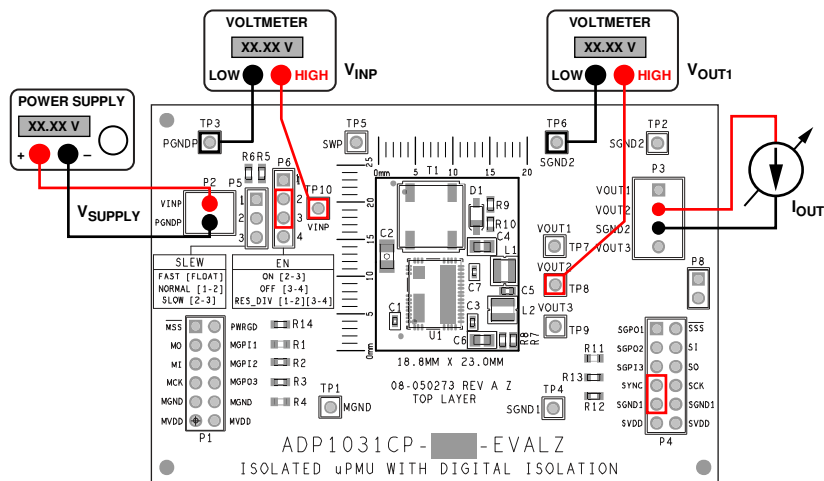

Figure 5. Buck Regulator Measurement Setup

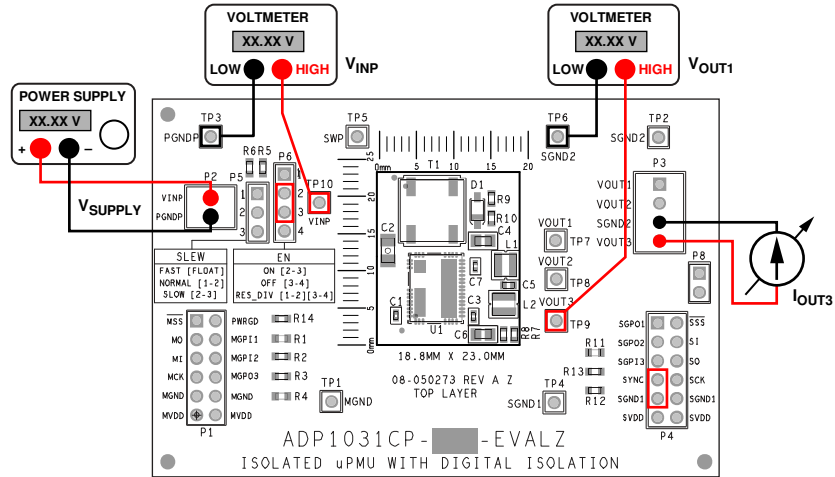

Figure 6. Inverting Measurement Setup

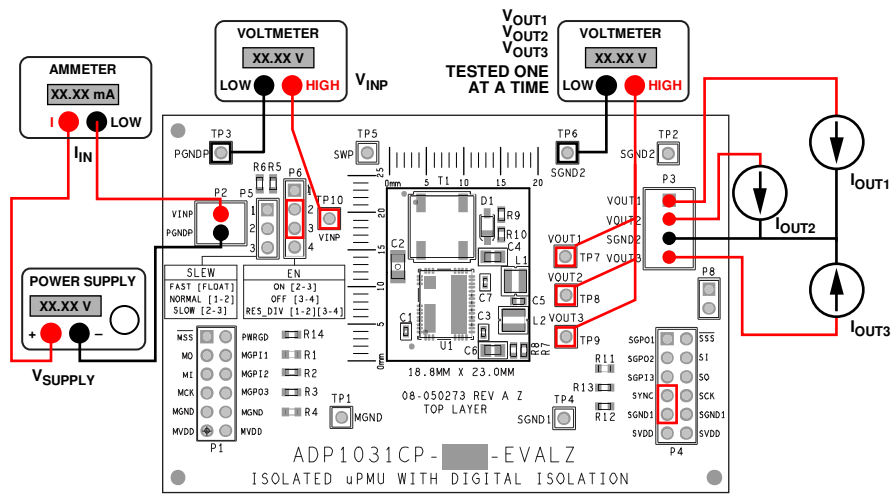

Figure 7. Overall Efficiency Measurement Setup

DATA INPUT/OUTPUT (I/O) MEASUREMENT

Each data channel, and the associated power supply input, is accessed through the P1 header connector and P4 header connector. Each side of the ADP1031CP-EVALZ isolator requires an off-board power source. The power sources must be independent from each other if users want to apply common-mode voltages across the isolation barrier. Sharing a single power supply for MVDD and SVDD does not harm the isolator. Sharing a power supply is also useful for testing the ADP1031 digital isolators when common-mode voltages are not present.

A 100 kΩ pull-down resistor to ground is installed on each digital input. A 100 kΩ pull-up resistor is installed across the PWRGD output and MVDD.

To properly operate the SPI channels and GPIO channels, refer the ADP1031 data sheet.

HIGH VOLTAGE CAPABILITY

Take appropriate care when using the evaluation board at high voltages. Do not rely on the printed circuit board (PCB) for safety functions because the PCB has not been high potential tested (also known as hipot tested or dielectric withstanding voltage tested) nor certified for safety.

OUTPUT VOLTAGE MEASUREMENTS

For accurate output voltage measurements from the evaluation board, connect the evaluation board to a voltage source and a voltmeter. Use a resistor or an electronic load (E-Load) as the load for the regulators.

Ensure that the resistor has an adequate power rating to handle the expected power dissipation. Taking into account the device efficiency, ensure that the power supply has enough current for the expected load levels.

Use the following steps to connect the power supply and voltmeter to the evaluation board (refer to Figure 4 through Figure 7 for setup diagrams):

1. Connect the negative terminal (-) of the power supply and voltmeter to the PGNDP power terminal in Connector P2 on the left side of the evaluation board.
2. Connect the positive terminal (+) of the power supply to the VINP terminal in Connector P2 on the left hand side of the evaluation board.
3. Connect a voltmeter across the VINP at TP10, and connect PGNDP at TP3 to monitor the actual input voltage supplied to the ADP1031.
4. Connect a load between the VOUT1, VOUT2, or VOUT3 terminal and the SGND2 terminal at the output connector (P3) on the right side of the evaluation board.
5. Connect the voltmeters to the output test points (TP7 for VOUT1, TP8 for VOUT2, and TP9 for VOUT3) in reference to SGND2 or SGND1.

Turn on the voltage source for VINP by pressing the power button. The regulators power up if Pin 2 and Pin 3 are connected to the EN jumper (P6).

If long power leads are used from the power supply, especially with higher loads, users are recommended to use a large capacitor (100 μ F or more) connected across the VINP terminals and PGNDP to prevent losses from lead inductance. Likewise, adjust the input voltage to ensure that the supply voltage is within the user specified target range. A power supply with a 4-wire supply and sense arrangement can be used as an alternative to manually adjusting the supply voltage to be within the user specified range.

LINE REGULATION

For line regulation measurements, the voltmeter measures the regulator output while the input supply is varied. The line regulation measurement can be repeated under different load conditions. During line regulation tests, the leads to the power supply must be short, and any additional input capacitor must be removed. Figure 8 shows the typical line regulation performance of the ADP1031 flyback regulator output.

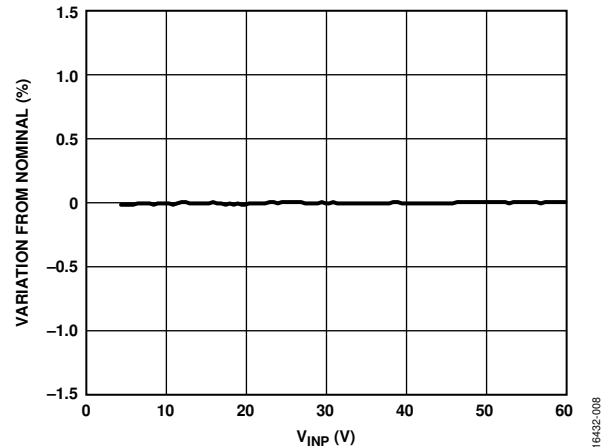

Figure 8. Flyback Regulator Output Line Regulation, Flyback Regulator Output Voltage (V_{OUT1}) = 24 V, Flyback Regulator Output Current (I_{OUT1}) = 20 mA, $T_A = 25^\circ\text{C}$, Load Regulation, Nominal = V_{OUT1} at 24 V Input Supply

LOAD REGULATION

For load regulation measurements, monitor the regulator output while the load is varied. The input voltage must be held constant during the load regulation measurement. Figure 9, Figure 10, and Figure 11 show the typical ADP1031 load regulation performance at the flyback regulator output, buck regulator output and inverting regulator output, respectively. Keep power leads short during this test and ensure that the supply voltage is constant under all load conditions.

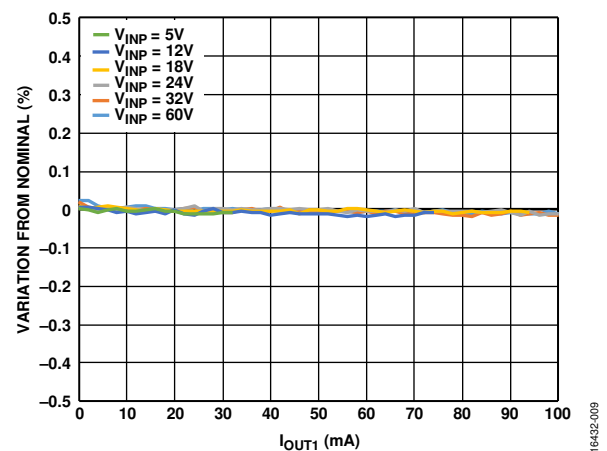

Figure 9. Flyback Regulator Output Load Regulation, $V_{OUT1} = 24\text{ V}$, $T_A = 25^\circ\text{C}$, Nominal = V_{OUT1} at 20 mA Load

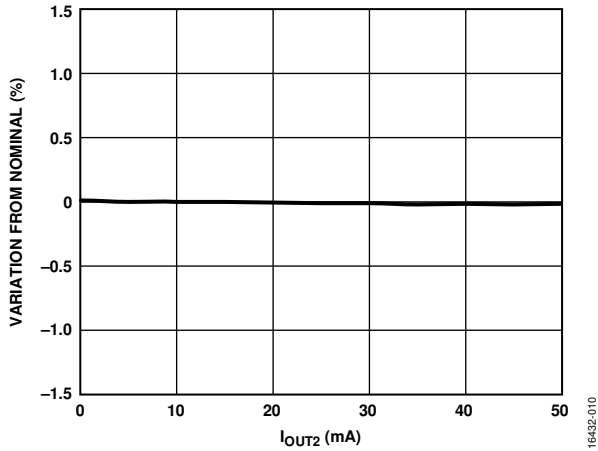

Figure 10. Buck Regulator Output Load Regulation, $V_{OUT1} = 24\text{ V}$, $V_{OUT2} = 5.15\text{ V}$, $T_A = 25^\circ\text{C}$, Nominal = V_{OUT2} at 10 mA Load

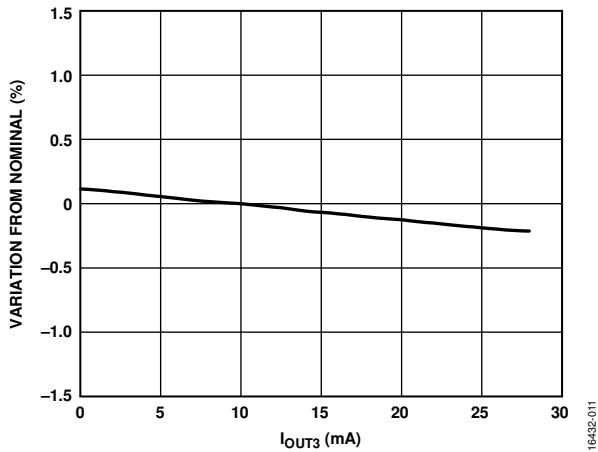

Figure 11. Inverting Regulator Output Load Regulation, $V_{OUT1} = 24\text{ V}$, $V_{OUT3} = -15\text{ V}$, $T_A = 25^\circ\text{C}$, Nominal = V_{OUT3} at -7 mA Load

EFFICIENCY

For efficiency measurements, monitor the regulator input supply and output voltages while the load is varied. Keep power leads short during the efficiency measurement test and use a power supply with remote sense. Connect ammeters in series with the input supply and the loads. Connect voltmeters to the test points provided for the input and the outputs of the regulators. For the most accurate results, measure the voltage across the input and output capacitors. If possible, particularly at a low current, trigger the meters simultaneously and set the meters to perform average readings for a period of a few hundred milliseconds.

Figure 12 shows the typical overall efficiency curve for the ADP1031 with a varying output load on the flyback regulator, and a constant load on the buck and the inverting regulators.

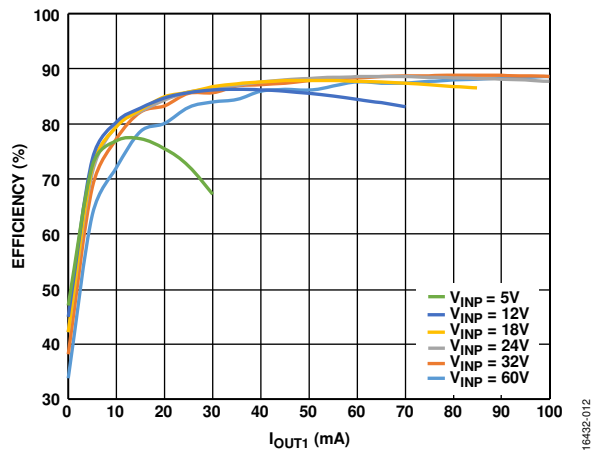

Figure 12. ADP1031 Overall Efficiency with Various Input Voltages, $V_{OUT1} = 24\text{ V}$, $V_{OUT2} = 5.15\text{ V}$, $I_{OUT2} = 7\text{ mA}$, $V_{OUT3} = -15\text{ V}$, $I_{OUT3} = -0.3\text{ mA}$, $T_A = 25^\circ\text{C}$

EVALUATION BOARD SCHEMATICS AND ARTWORK

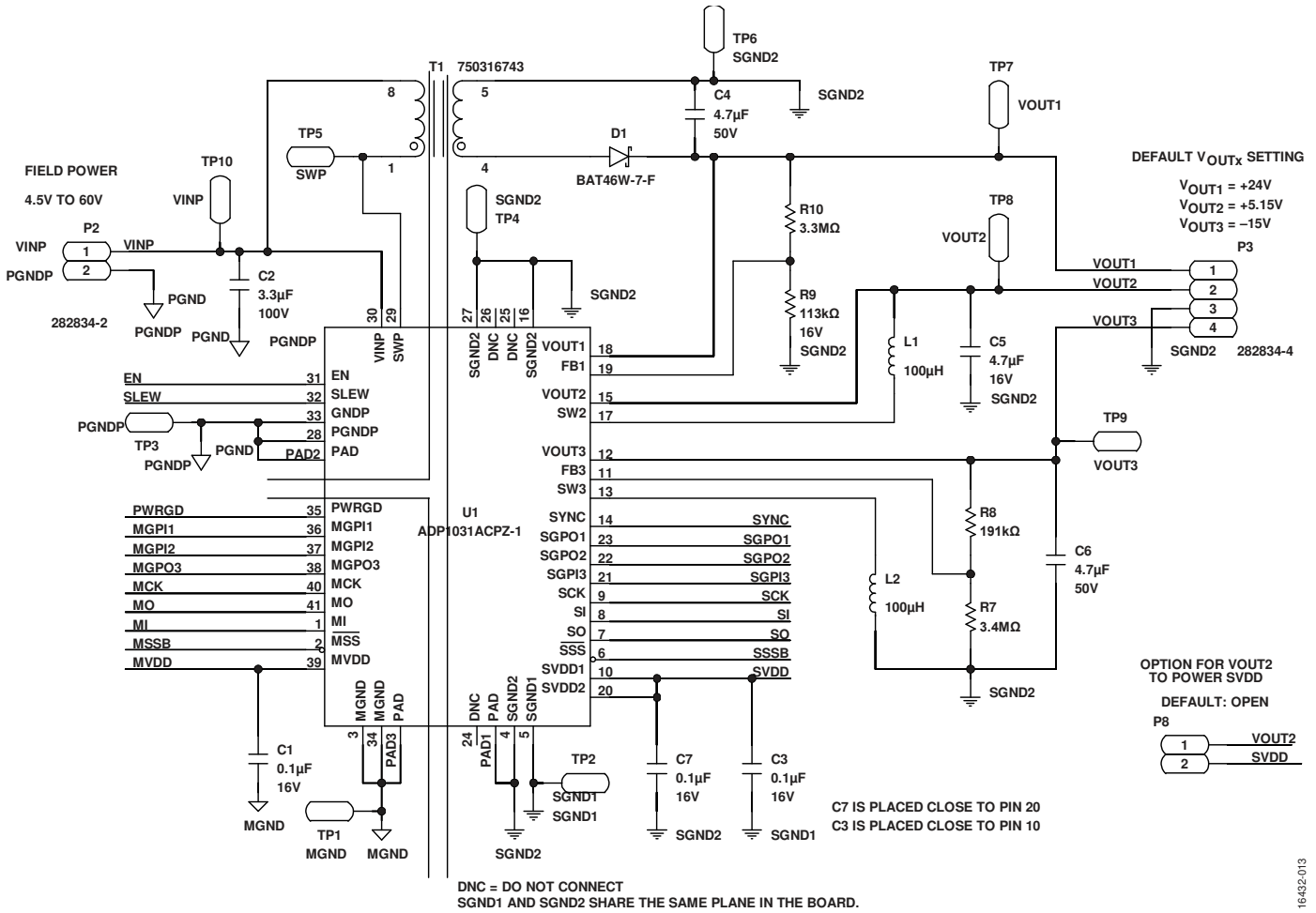

Figure 13. ADP1031CP-EVALZ Evaluation Board Schematic

16432-013

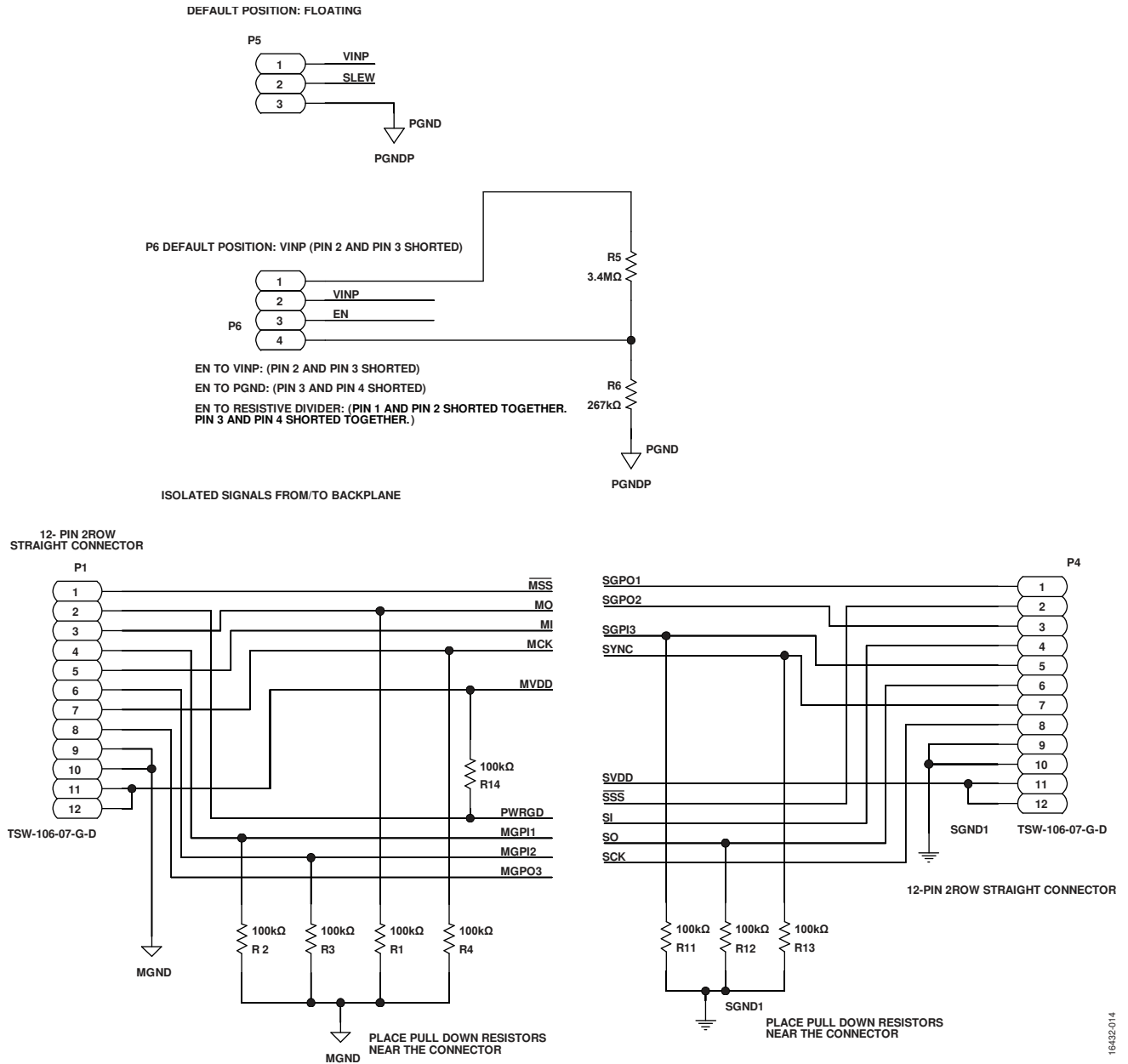

Figure 14. ADP1031CP-EVALZ Evaluation Board Schematic—Connectors and Peripherals

16432/014

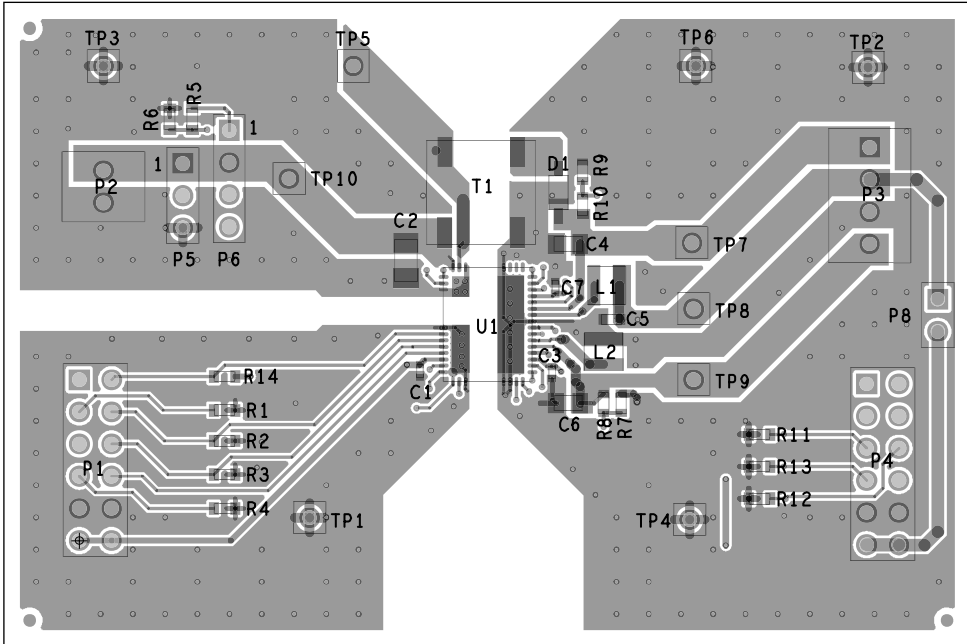

Figure 15. ADP1031CP-EVALZ Evaluation Board Top Layer

16432-015

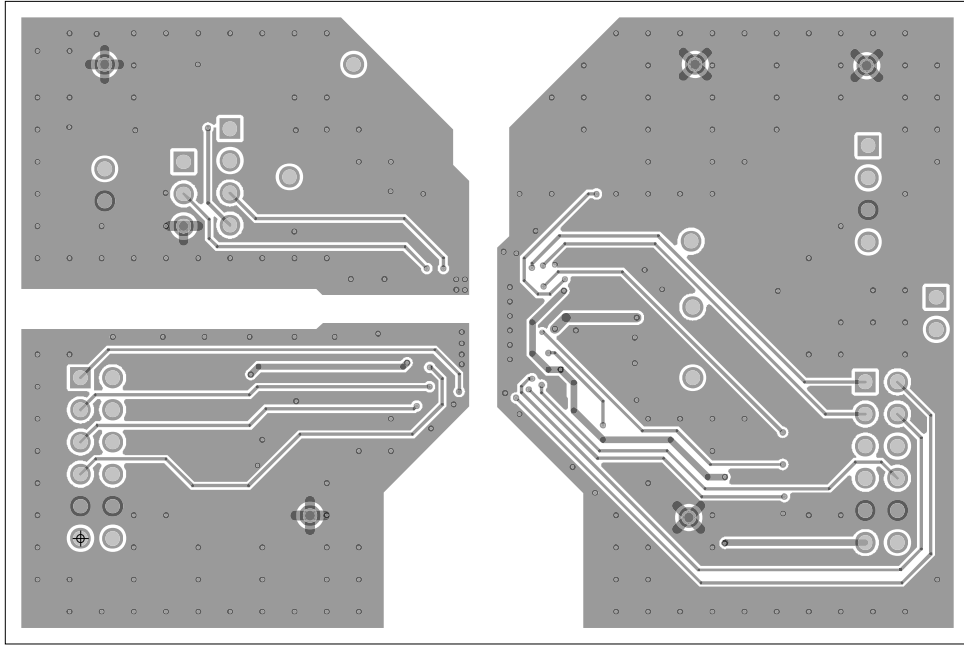
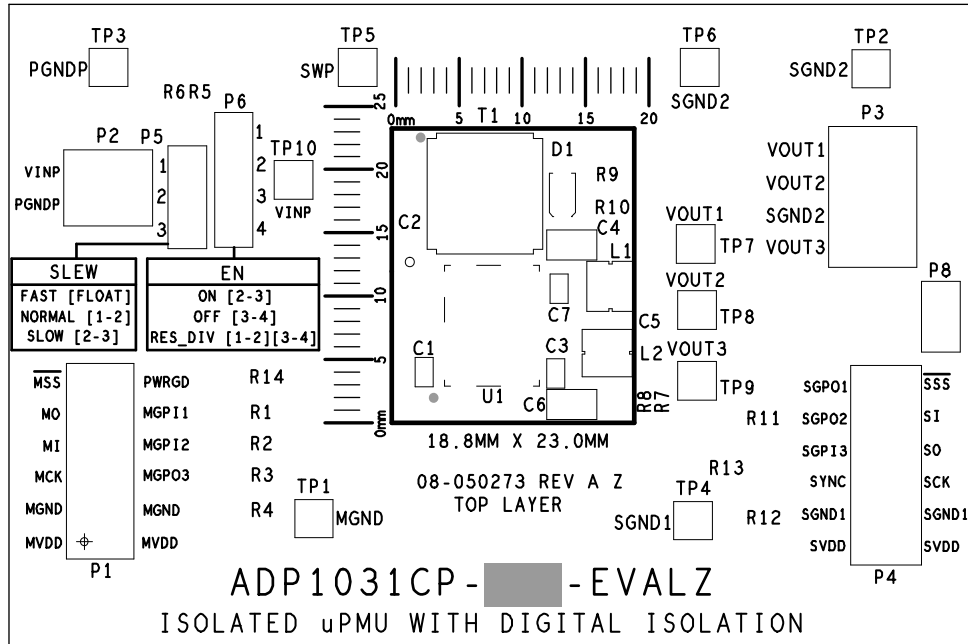

Figure 16. ADP1031CP-EVALZ Evaluation Board Bottom Layer

16432-016



16432-017

Figure 17. ADP1031CP-EVALZ Evaluation Board Silkscreen (Top)

ORDERING INFORMATION

BILL OF MATERIALS

Table 3. Bill of Materials

Quantity ¹	Reference Designator	Description	Manufacturer	Part Number
3	C1, C3, C7	Capacitors, MLCC, 0.1 μ F, 16 V, 0402, X7R	Not applicable	Not applicable
1	C2	Capacitor, MLCC, 3.3 μ F, 100 V, 1206, X7S	TDK Corporation	C3216X7S2A335K160AB
2	C4, C6	Capacitors, MLCC, 4.7 μ F, 50 V, 0805, X7R	Murata	GRM21BZ71H475KE15L
1	C5	Capacitor, MLCC, 4.7 μ F, 16 V, 0603, X7R	Murata	GRM188C81C475KE11D
1	D1	Diode, Schottky rectifier, surface-mount device (SMD)	Diodes Incorporated	BAT46W-7-F
2	L1, L2	Inductors, shielded, 100 μ H, 0.39 A	Coilcraft	XFL3012-104MEB
2	P1, P4	Headers, 12-pin	Samtec	TSW-106-07-G-D
1	P2	Terminal block, 2-pin	TE Connectivity	282834-2
1	P3	Terminal block, 4-pin	TE Connectivity	282834-4
1	P5	Header, 3-pin	Samtec	TSW-103-07-F-S
1	P6	Header, 4-pin	Samtec	TSW-104-07-G-S
10	TP1, TP2, TP3, TP4, TP5, TP6, TP7, TP8, TP9, TP10	Headers, 1-pin	Samtec	TSW-101-07-G-S
1	P8	Header, 2-pin	Samtec	TSW-101-07-G-D
8	R1, R2, R3, R4, R11, R12, R13, R14	Resistors, 100 k Ω , 1/10 W, 1%, 0603, SMD	Not applicable	Not applicable
2	R5, R7	Resistors, 3.4 M Ω , 1/10 W, 1%, 0603, SMD	Not applicable	Not applicable
1	R6	Resistor, 267 k Ω , 1/10 W, 1%, 0603, SMD	Not applicable	Not applicable
1	R8	Resistor, 191 k Ω , 1/10 W, 1%, 0603, SMD	Not applicable	Not applicable
1	R9	Resistor, 113 k Ω , 1/10 W, 1%, 0603, SMD	Not applicable	Not applicable
1	R10	Resistor, 3.3 M Ω , 1/10 W, 1%, 0603, SMD	Not applicable	Not applicable
1	T1	Transformer, 1:1 turn ratio, 300 μ H, 350 mA	Würth Elektronik	750316743
1	U1	3-channel isolated micropower management unit with 7-channel digital isolators	Analog Devices	ADP1031ACPZ-1 , ADP1031ACPZ-2 , ADP1031ACPZ-3 , ADP1031ACPZ-4 , ADP1031ACPZ-5

¹ R9 and R10 are not installed for the [ADP1031CP-4](#) and [ADP1031CP-5](#) board models.

NOTES

**ESD Caution**

ESD (electrostatic discharge) sensitive device. Charged devices and circuit boards can discharge without detection. Although this product features patented or proprietary protection circuitry, damage may occur on devices subjected to high energy ESD. Therefore, proper ESD precautions should be taken to avoid performance degradation or loss of functionality.

Legal Terms and Conditions

By using the evaluation board discussed herein (together with any tools, components documentation or support materials, the "Evaluation Board"), you are agreeing to be bound by the terms and conditions set forth below ("Agreement") unless you have purchased the Evaluation Board, in which case the Analog Devices Standard Terms and Conditions of Sale shall govern. Do not use the Evaluation Board until you have read and agreed to the Agreement. Your use of the Evaluation Board shall signify your acceptance of the Agreement. This Agreement is made by and between you ("Customer") and Analog Devices, Inc. ("ADI"), with its principal place of business at One Technology Way, Norwood, MA 02062, USA. Subject to the terms and conditions of the Agreement, ADI hereby grants to Customer a free, limited, personal, temporary, non-exclusive, non-sublicensable, non-transferable license to use the Evaluation Board FOR EVALUATION PURPOSES ONLY. Customer understands and agrees that the Evaluation Board is provided for the sole and exclusive purpose referenced above, and agrees not to use the Evaluation Board for any other purpose. Furthermore, the license granted is expressly made subject to the following additional limitations: Customer shall not (i) rent, lease, display, sell, transfer, assign, sublicense, or distribute the Evaluation Board; and (ii) permit any Third Party to access the Evaluation Board. As used herein, the term "Third Party" includes any entity other than ADI, Customer, their employees, affiliates and in-house consultants. The Evaluation Board is NOT sold to Customer; all rights not expressly granted herein, including ownership of the Evaluation Board, are reserved by ADI. CONFIDENTIALITY. This Agreement and the Evaluation Board shall all be considered the confidential and proprietary information of ADI. Customer may not disclose or transfer any portion of the Evaluation Board to any other party for any reason. Upon discontinuation of use of the Evaluation Board or termination of this Agreement, Customer agrees to promptly return the Evaluation Board to ADI. ADDITIONAL RESTRICTIONS. Customer may not disassemble, decompile or reverse engineer chips on the Evaluation Board. Customer shall inform ADI of any occurred damages or any modifications or alterations it makes to the Evaluation Board, including but not limited to soldering or any other activity that affects the material content of the Evaluation Board. Modifications to the Evaluation Board must comply with applicable law, including but not limited to the RoHS Directive. TERMINATION. ADI may terminate this Agreement at any time upon giving written notice to Customer. Customer agrees to return to ADI the Evaluation Board at that time. LIMITATION OF LIABILITY. THE EVALUATION BOARD PROVIDED HEREUNDER IS PROVIDED "AS IS" AND ADI MAKES NO WARRANTIES OR REPRESENTATIONS OF ANY KIND WITH RESPECT TO IT. ADI SPECIFICALLY DISCLAIMS ANY REPRESENTATIONS, ENDORSEMENTS, GUARANTEES, OR WARRANTIES, EXPRESS OR IMPLIED, RELATED TO THE EVALUATION BOARD INCLUDING, BUT NOT LIMITED TO, THE IMPLIED WARRANTY OF MERCHANTABILITY, TITLE, FITNESS FOR A PARTICULAR PURPOSE OR NON-INFRINGEMENT OF INTELLECTUAL PROPERTY RIGHTS. IN NO EVENT WILL ADI AND ITS LICENSORS BE LIABLE FOR ANY INCIDENTAL, SPECIAL, INDIRECT, OR CONSEQUENTIAL DAMAGES RESULTING FROM CUSTOMER'S POSSESSION OR USE OF THE EVALUATION BOARD, INCLUDING BUT NOT LIMITED TO LOST PROFITS, DELAY COSTS, LABOR COSTS OR LOSS OF GOODWILL. ADI'S TOTAL LIABILITY FROM ANY AND ALL CAUSES SHALL BE LIMITED TO THE AMOUNT OF ONE HUNDRED US DOLLARS (\$100,000). EXPORT. Customer agrees that it will not directly or indirectly export the Evaluation Board to another country, and that it will comply with all applicable United States federal laws and regulations relating to exports. GOVERNING LAW. This Agreement shall be governed by and construed in accordance with the substantive laws of the Commonwealth of Massachusetts (excluding conflict of law rules). Any legal action regarding this Agreement will be heard in the state or federal courts having jurisdiction in Suffolk County, Massachusetts, and Customer hereby submits to the personal jurisdiction and venue of such courts. The United Nations Convention on Contracts for the International Sale of Goods shall not apply to this Agreement and is expressly disclaimed.

©2019 Analog Devices, Inc. All rights reserved. Trademarks and registered trademarks are the property of their respective owners.
UG16432-0-1/19(0)



www.analog.com