

CS5207A-1

7.0 A LDO 3-Pin Adjustable Linear Regulator

The CS5207A-1 linear regulator provides 7.0 A at adjustable voltages from 1.25 V to 5.0 V. This adjustable device requires two external resistors to set the output voltage and provide the minimum load current for proper regulation.

This regulator is intended for use as a post regulator and microprocessor supply. The fast loop response and low dropout voltage make this regulator ideal for applications where low voltage operation and good transient response are important.

The circuit is designed to operate with dropout voltages as low as 1.0 V at 7.0 A.

This regulator is protected against overload conditions with overcurrent and thermal shutdown protection circuitry.

The CS5207A-1 is pin compatible with the LT1584 family of linear regulators but has lower dropout voltage and faster transient response.

This regulator is available in a TO-220 package.

Features

- 1.25 V to 5.0 V V_{OUT} @ 7.0 A
- Dropout Voltage < 1.0 V @ 7.0 A
- 1.5% Trimmed Reference
- Fast Transient Response
- Thermal Shutdown
- Current Limit
- Short Circuit Protection
- Drop-In Replacement for LT1584

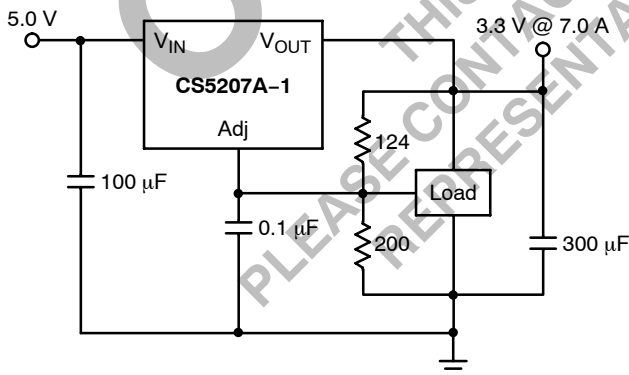
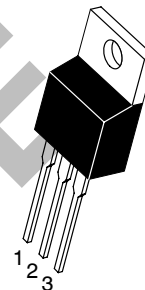

Figure 1. Applications Diagram



ON Semiconductor®

<http://onsemi.com>



TO-220
THREE LEAD
T SUFFIX
CASE 221A

PIN CONNECTIONS AND MARKING DIAGRAMS



Tab = V_{OUT}
Pin 1. Ad-just
2. V_{OUT}
3. V_{IN}

A = Assembly Location
WL, L = Wafer Lot
YY, Y = Year
WW, W = Work Week

ORDERING INFORMATION

Device	Package	Shipping
CS5207A-1GT3	TO-220*	50 Units/Rail

*TO-220 is 3-pin, straight leaded.

CS5207A-1

MAXIMUM RATINGS*

Parameter	Value	Unit	
Input Voltage	6.0	V	
Operating Junction Temperature Range	$0 \leq T_J \leq 150$	°C	
Storage Temperature Range	-60 to +150	°C	
Lead Temperature Soldering:	Wave Solder (through hole styles only) Note 1	260 Peak	°C
ESD Damage Threshold	2.0	kV	

1. 10 second maximum.

*The maximum package power dissipation must be observed.

ELECTRICAL CHARACTERISTICS (0°C ≤ T_A ≤ 70°C, 0°C ≤ T_J ≤ 150°C, V_{Adj} = 0 V, unless otherwise specified.)

Characteristic	Test Conditions	Min	Typ	Max	Unit
Adjustable Output Voltage					
Reference Voltage	V _{IN} = 2.75 V to 5.5 V, I _{OUT} = 10 mA to 7.0 A	1.234 (-1.5%)	1.253	1.271 (+1.5%)	V
Line Regulation	V _{IN} = 2.75 V to 5.5 V, I _{OUT} = 10 mA	-	0.02	0.20	%
Load Regulation	V _{IN} = 2.75 V, I _{OUT} = 10 mA to 7.0 A	-	0.04	0.50	%
Minimum Load Current (Note 2)	V _{IN} = 5.0 V, ΔV _{OUT} = +1.5%	-	5.0	10	mA
Adjust Pin Current	V _{IN} = 2.75 V, I _{OUT} = 10 mA	-	70	120	μA
Current Limit	V _{IN} = 2.75 V, ΔV _{OUT} = -1.5%	7.1	8.0	-	A
Short Circuit Current	V _{IN} = 2.75 V, V _{OUT} = 0 V	5.0	9.0	-	A
Ripple Rejection (Note 3)	V _{IN} = 3.25 V, V _{RIPPLE} = 1.0 V _{P-P} @ 120 Hz, I _{OUT} = 4.0 A, C _{Adj} = 0.1 μF; C _{OUT} = 22 μF	60	80	-	dB
Thermal Regulation (Note 3)	30 ms Pulse, T _A = 25°C	-	0.002	-	%/W
Dropout Voltage (Minimum V _{IN} -V _{OUT}) (Note 4)	I _{OUT} = 100 mA	-	0.92	1.15	V
	I _{OUT} = 1.0 A	-	0.93	1.15	V
	I _{OUT} = 2.75 A	-	0.94	1.15	V
	I _{OUT} = 4.0 A	-	0.95	1.15	V
	I _{OUT} = 7.0 A	-	0.96	1.25	V
RMS Output Noise	Freq = 10 Hz to 10 kHz, T _A = 25°C	-	0.003	-	%V _{OUT}
Temperature Stability	-	-	0.5	-	%
Thermal Shutdown (Note 5)	-	150	180	210	°C
Thermal Shutdown Hysteresis (Note 5)	-	-	25	-	°C

2. The minimum load current is the minimum current required to maintain regulation. Normally the current in the resistor divider used to set the output voltage is selected to meet the minimum load current requirement.

3. This parameter is guaranteed by design and is not 100% production tested.

4. Dropout voltage is defined as the minimum input/output voltage differential required to maintain 1.5% regulation.

5. This parameter is guaranteed by design, but not parametrically tested in production. However, a 100% thermal shutdown functional test is performed on each part.

CS5207A-1

PACKAGE PIN DESCRIPTION

Package Pin Number	Pin Symbol	Function
TO-220		
1	Adjust	This pin is connected to the low side of the internally trimmed 1.5% bandgap reference voltage and carries a bias current of about 70 μ A. A resistor divider from Adj to V_{OUT} and from Adj to ground sets the output voltage. Also, transient response can be improved by adding a small bypass capacitor from this pin to ground.
2	V_{OUT}	This pin is connected to the emitter of the power pass transistor and provides a regulated voltage capable of sourcing 7.0 A of current.
3	V_{IN}	This is the supply voltage for the regulator. For the device to regulate, this voltage should be between 1.0 V and 1.25 V (depending on the output current) greater than the output voltage.

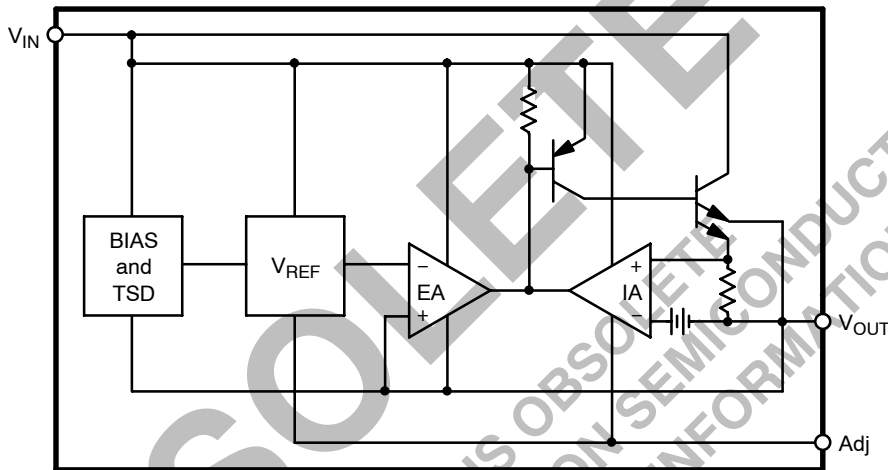

Figure 2. Block Diagram

TYPICAL PERFORMANCE CHARACTERISTICS

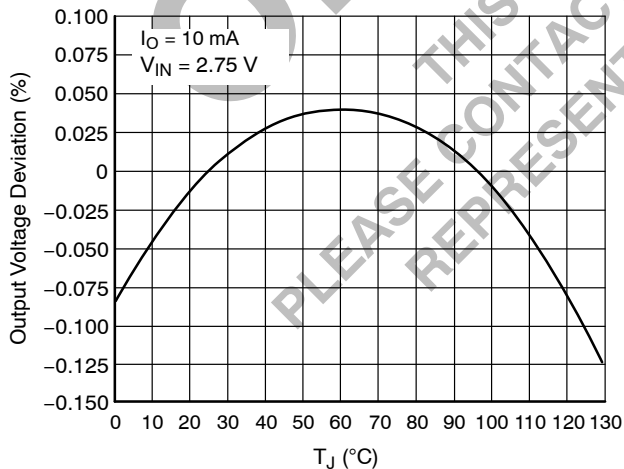

Figure 3. Reference Voltage vs. Temperature

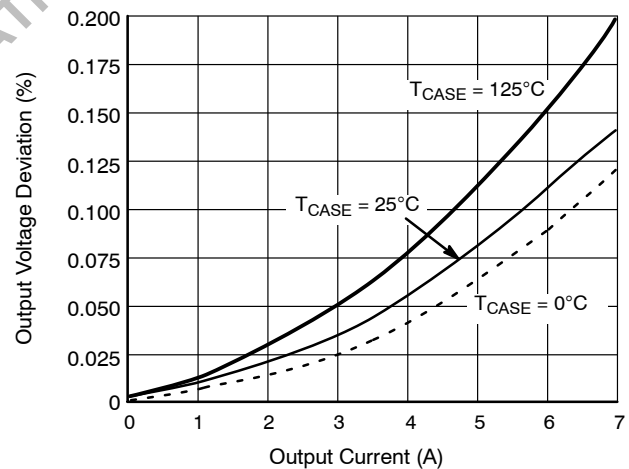

Figure 4. Load Regulation vs. Output Current

CS5207A-1

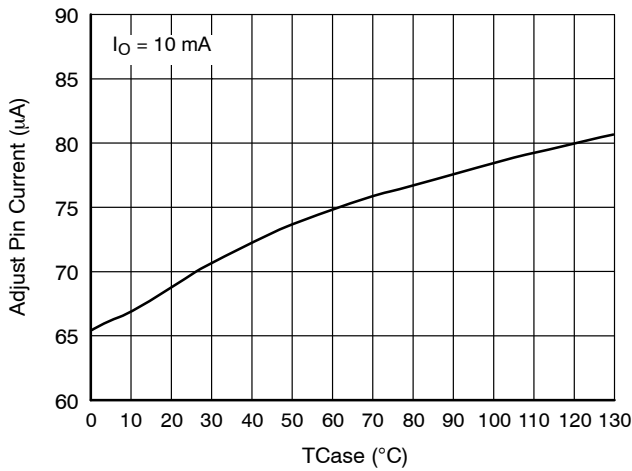

Figure 5. Adjust Pin Current vs. Temperature

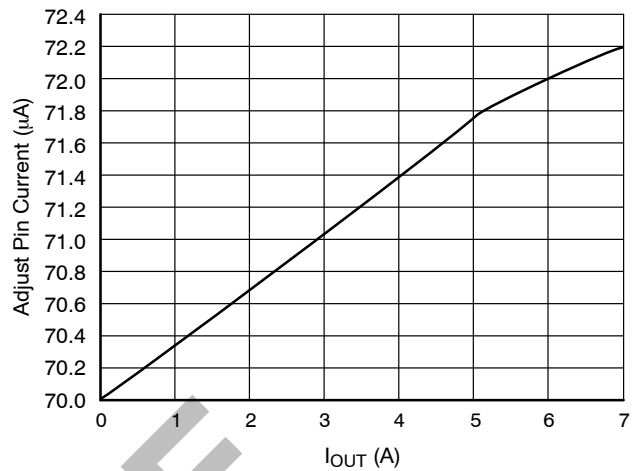

Figure 6. Adjust Pin vs. IO

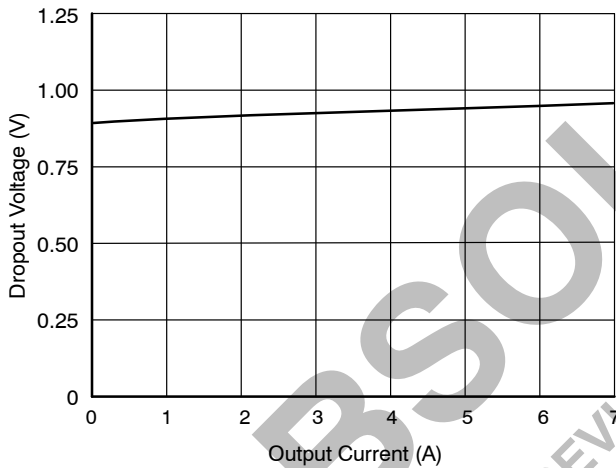

Figure 7. Dropout Voltage vs. Output Current

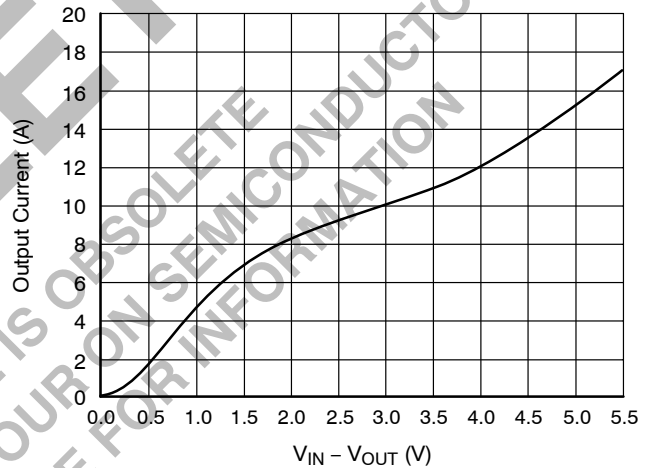

Figure 8. Short Circuit vs. VIN - VOUT

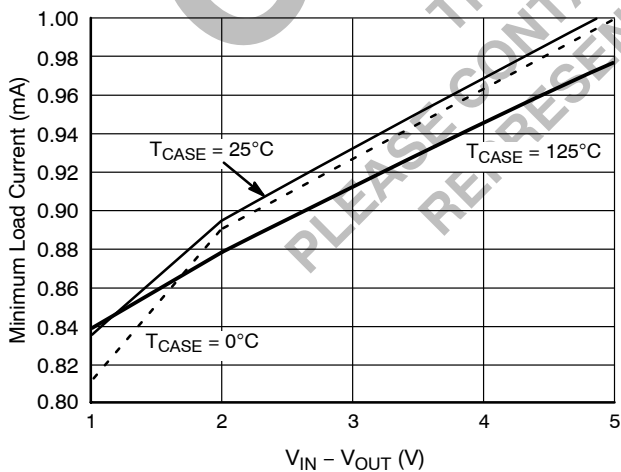

Figure 9. Minimum Load Current vs. VIN - VOUT

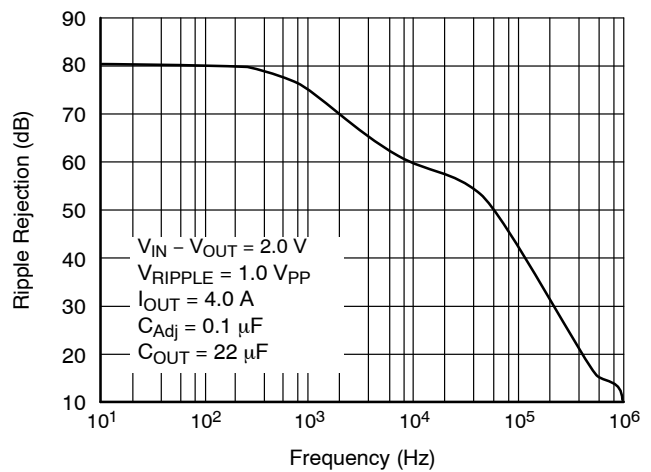

Figure 10. Ripple Rejection vs. Frequency

APPLICATION NOTES

THEORY OF OPERATION

The CS5207A-1 linear regulator has a composite PNP-NPN output stage that requires an output capacitor for stability. A detailed procedure for selecting this capacitor is included in the Stability Considerations section.

ADJUSTABLE OPERATION

Design Guidelines

This LDO adjustable regulator has an output voltage range of 1.25 V to 5.0 V. An external resistor divider sets the output voltage as shown in Figure 11. The regulator's voltage sensing error amplifier maintains a fixed 1.25 V reference between the output pin and the adjust pin.

A resistor divider network R_1 and R_2 causes a fixed current to flow to ground. This current creates a voltage across R_2 that adds to the 1.25 V across R_1 and sets the overall output voltage. The adjust pin current (typically 50 μ A) also flows through R_2 and adds a small error that should be taken into account if precise adjustment of V_{OUT} is necessary. The output voltage is set according to the formula:

$$V_{OUT} = V_{REF} \times \left(\frac{R_1 + R_2}{R_1} \right) + R_2 \times I_{Adj}$$

The term $I_{Adj} \times R_2$ represents the error added by the adjust pin current.

R_1 is chosen so that the minimum load current is at least 10 mA. R_1 and R_2 should be of the same composition for best tracking over temperature. For best results, the divider resistor should be placed near the regulator with a separate metal trace connecting them to output..

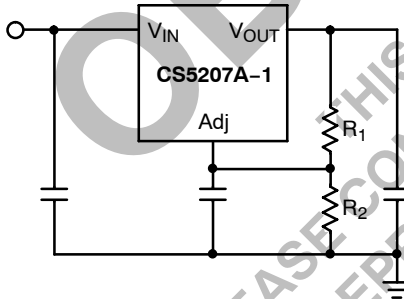

Figure 11.

While not required, a bypass capacitor connected between the adjust pin and ground will improve transient response and ripple rejection. A 0.1 μ F tantalum capacitor is recommended for "first cut" design. Value and type may be varied to optimize performance vs price.

OTHER ADJUSTABLE OPERATION CONSIDERATIONS

The CS5207A-1 linear regulator has an absolute maximum specification of 6.0 V for the voltage difference between V_{IN} and V_{OUT} . However, the IC may be used to regulate voltages in excess of 6.0 V. The main considerations in such a design are power-up and short circuit capability.

In most applications, ramp-up of the power supply to V_{IN} is fairly slow, typically on the order of several tens of milliseconds, while the regulator responds in less than one microsecond. In this case, the linear regulator begins charging the output capacitor as soon as the V_{IN} to V_{OUT} differential is large enough that the pass transistor conducts current. V_{OUT} is essentially at ground, and V_{IN} is on the order of several hundred millivolts, so the pass transistor is in dropout. As V_{IN} increases, the pass transistor will remain in dropout, and current is passed to the load until V_{OUT} is in regulation. Further increase in V_{IN} brings the pass transistor out of dropout. The result is that the output voltage follows the power supply ramp-up, staying in dropout until the regulation point is reached. In this manner, any output voltage may be regulated. There is no theoretical limit to the regulated voltage as long as the V_{IN} to V_{OUT} differential of 6.0 V is not exceeded.

However, maximum ratings of the IC will be exceeded in a short circuit condition. Short circuit conditions will result in the immediate operation of the pass transistor outside of its safe operating area. Over-voltage stresses will then cause destruction of the pass transistor before overcurrent or thermal shutdown circuitry can become active. Additional circuitry may be required to clamp V_{IN} to V_{OUT} differential to less than 6.0 V if failsafe operation is required. One possible clamp circuit is illustrated in Figure 12; however, the design of clamp circuitry must be done on an application by application basis. Care must be taken to ensure the clamp actually protects the design. Components used in the clamp design must be able to withstand the short circuit conditions indefinitely while protecting the IC.

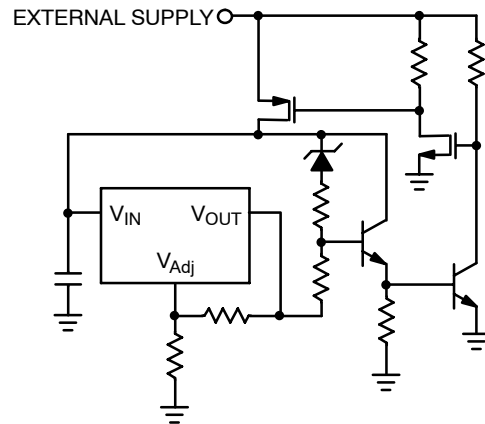

Figure 12.

STABILITY CONSIDERATIONS

The output compensation capacitor helps determine three main characteristics of a linear regulator: start-up delay, load transient response, and loop stability.

The capacitor value and type is based on cost, availability, size and temperature constraints. A tantalum or aluminum electrolytic capacitor is best, since a film or ceramic capacitor with almost zero ESR can cause instability. The aluminum electrolytic capacitor is the least expensive solution. However, when the circuit operates at low temperatures, both the value and ESR of the capacitor will vary considerably. The capacitor manufacturer's data sheet provides this information.

A 300 μF tantalum capacitor will work for most applications, but with high current regulators such as the CS5207A-1 the transient response and stability improve with higher values of capacitance. The majority of applications for this regulator involve large changes in load current so the output capacitor must supply the instantaneous load current. The ESR of the output capacitor causes an immediate drop in output voltage given by:

$$\Delta V = \Delta I \times ESR$$

For microprocessor applications it is customary to use an output capacitor network consisting of several tantalum and ceramic capacitors in parallel. This reduces the overall ESR and reduces the instantaneous output voltage drop under transient load conditions. The output capacitor network should be as close to the load as possible for the best results.

Protection Diodes

When large external capacitors are used with a linear regulator it is sometimes necessary to add protection diodes. If the input voltage of the regulator gets shorted, the output capacitor will discharge into the output of the regulator. The discharge current depends on the value of the capacitor, the output voltage and the rate at which V_{IN} drops. In the CS5207A-1 regulator, the discharge path is through a large junction and protection diodes are not usually needed. If the regulator is used with large values of output capacitance and the input voltage is instantaneously shorted to ground, damage can occur. In this case, a diode connected as shown in Figure 13 is recommended.

A rule of thumb useful in determining if a protection diode is required is to solve for current

$$I = \frac{C \times V}{T}$$

where:

- I is the current flow out of the load capacitance when V_{IN} is shorted,
- C is the value of the load capacitance,
- V is the output voltage, and
- T is the time duration required for V_{IN} to transition from high to being shorted.

If the calculated current is greater than or equal to the typical short circuit current value provided in the specifications, serious thought should be given to including a protection diode.

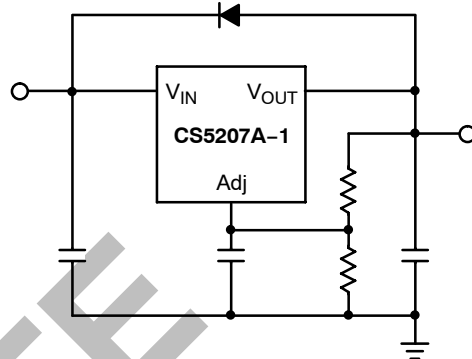

Figure 13.

Current Limit

The internal current limit circuit limits the output current under excessive load conditions and protects the regulator.

Short Circuit Protection

The device includes foldback short circuit current limit that clamps the output current at approximately two amperes less than its current limit value.

Thermal Shutdown

The thermal shutdown circuitry is guaranteed by design to become activated above a die junction temperature of 150°C and to shut down the regulator output. This circuitry includes a thermal hysteresis circuit with 25°C of typical hysteresis, thereby allowing the regulator to recover from a thermal fault automatically.

Calculating Power Dissipation and Heat Sink Requirements

High power regulators such as the CS5207A-1 usually operate at high junction temperatures. Therefore, it is important to calculate the power dissipation and junction temperatures accurately to ensure that an adequate heat sink is used. Since the package tab is connected to V_{OUT} on the CS5207A-1, electrical isolation may be required for some applications. Also, as with all high power packages, thermal compound is necessary to ensure proper heat flow. For added safety, this high current LDO includes an internal thermal shutdown circuit

The thermal characteristics of an IC depend on the following four factors. Junction temperature, ambient temperature, die power dissipation, and the thermal resistance from the die junction to ambient air. The maximum junction temperature can be determined by:

$$T_{J(max)} = T_{A(max)} + PD(max) \times R_{\theta JA}$$

CS5207A-1

The maximum ambient temperature and the power dissipation are determined by the design while the maximum junction temperature and the thermal resistance depend on the manufacturer and the package type. The maximum power dissipation for a regulator is:

$$P_{D(max)} = (V_{IN(max)} - V_{OUT(min)})I_{OUT(max)} + V_{IN(max)} \times I_{IN(max)}$$

A heat sink effectively increases the surface area of the package to improve the flow of heat away from the IC and into the surrounding air. Each material in the heat flow path between the IC and the outside environment has a thermal resistance. Like series electrical resistances, these resistances are summed to determine the total thermal resistance between the die junction and the surrounding air, $R_{\theta JC}$. This total thermal resistance is comprised of three components. These resistive terms are measured from

junction to case ($R_{\theta JC}$), case to heat sink ($R_{\theta CS}$), and heat sink to ambient air ($R_{\theta SA}$). The equation is:

$$R_{\theta JA} = R_{\theta JC} + R_{\theta CS} + R_{\theta SA}$$

$R_{\theta JC}$ is rated @ 1.4°C/W for the CS5207A-1. For a high current regulator such as the CS5207A-1 the majority of heat is generated in the power transistor section. The value for $R_{\theta SA}$ depends on the heat sink type, while the $R_{\theta CS}$ depends on factors such as package type, heat sink interface (is an insulator and thermal grease used?), and the contact area between the heat sink and the package. Once these calculations are complete, the maximum permissible value of $R_{\theta JA}$ can be calculated and the proper heat sink selected. For further discussion on heat sink selection, see application note "Thermal Management," document number AND8036/D, available through the Literature Distribution Center or via our website at <http://onsemi.com>.

OBSOLETE
THIS DEVICE IS OBSOLETE
PLEASE CONTACT YOUR ON SEMICONDUCTOR
REPRESENTATIVE FOR INFORMATION

CS5207A-1

PACKAGE DIMENSIONS

TO-220
THREE LEAD
T SUFFIX
CASE 221A-08
ISSUE AA

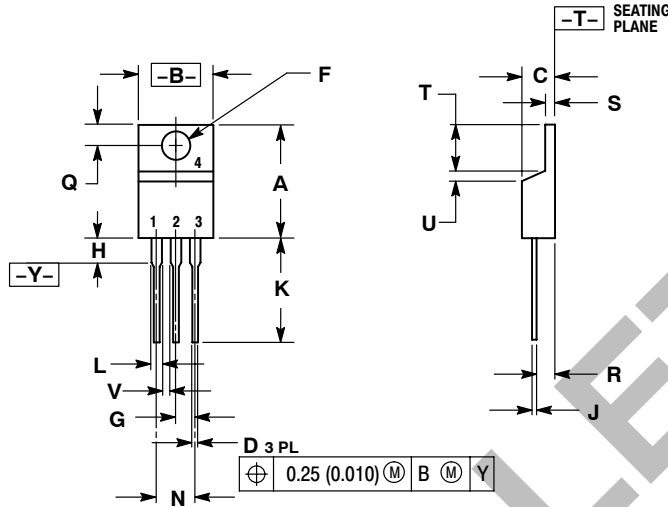

NOTES:

- DIMENSIONING AND TOLERANCING PER ANSI Y14.5M, 1982.
- CONTROLLING DIMENSION: INCH.

DIM	INCHES		MILLIMETERS	
	MIN	MAX	MIN	MAX
A	0.560	0.625	14.23	15.87
B	0.380	0.420	9.66	10.66
C	0.140	0.190	3.56	4.82
D	0.025	0.035	0.64	0.89
F	0.139	0.155	3.53	3.93
G	0.100 BSC		2.54 BSC	
H	---	0.280	---	7.11
J	0.012	0.045	0.31	1.14
K	0.500	0.580	12.70	14.73
L	0.045	0.060	1.15	1.52
N	0.200 BSC		5.08 BSC	
Q	0.100	0.135	2.54	3.42
R	0.080	0.115	2.04	2.92
S	0.020	0.055	0.51	1.39
T	0.235	0.265	5.97	6.47
U	0.000	0.050	0.00	1.27
V	0.045	---	1.15	---

PACKAGE THERMAL DATA

Parameter		TO-220 THREE LEAD	Unit
R _{θJC}	Typical	1.4	°C/W
R _{θJA}	Typical	50	°C/W

ON Semiconductor and are registered trademarks of Semiconductor Components Industries, LLC (SCILLC). SCILLC reserves the right to make changes without further notice to any products herein. SCILLC makes no warranty, representation or guarantee regarding the suitability of its products for any particular purpose, nor does SCILLC assume any liability arising out of the application or use of any product or circuit, and specifically disclaims any and all liability, including without limitation special, consequential or incidental damages. "Typical" parameters which may be provided in SCILLC data sheets and/or specifications can and do vary in different applications and actual performance may vary over time. All operating parameters, including "Typicals" must be validated for each customer application by customer's technical experts. SCILLC does not convey any license under its patent rights nor the rights of others. SCILLC products are not designed, intended, or authorized for use as components in systems intended for surgical implant into the body, or other applications intended to support or sustain life, or for any other application in which the failure of the SCILLC product could create a situation where personal injury or death may occur. Should Buyer purchase or use SCILLC products for any such unintended or unauthorized application, Buyer shall indemnify and hold SCILLC and its officers, employees, subsidiaries, affiliates, and distributors harmless against all claims, costs, damages, and expenses, and reasonable attorney fees arising out of, directly or indirectly, any claim of personal injury or death associated with such unintended or unauthorized use, even if such claim alleges that SCILLC was negligent regarding the design or manufacture of the part. SCILLC is an Equal Opportunity/Affirmative Action Employer. This literature is subject to all applicable copyright laws and is not for resale in any manner.

PUBLICATION ORDERING INFORMATION

LITERATURE FULFILLMENT:
Literature Distribution Center for ON Semiconductor
P.O. Box 5163, Denver, Colorado 80217 USA
Phone: 303-675-2175 or 800-344-3860 Toll Free USA/Canada
Fax: 303-675-2176 or 800-344-3867 Toll Free USA/Canada
Email: orderlit@onsemi.com

N. American Technical Support: 800-282-9855 Toll Free
USA/Canada
Europe, Middle East and Africa Technical Support:
Phone: 421 33 790 2910
Japan Customer Focus Center
Phone: 81-3-5773-3850

ON Semiconductor Website: www.onsemi.com
Order Literature: <http://www.onsemi.com/orderlit>
For additional information, please contact your local
Sales Representative