

FEATURES

- Filterless Class-D amplifier with Σ - Δ modulation
- No sync necessary when using multiple Class-D amplifiers from Analog Devices, Inc.
- 1.4 W into 8 Ω at 5.0 V supply with less than 1% THD + N
- 85% efficiency at 5.0 V, 1.4 W into 8 Ω speaker
- Greater than 98 dB SNR (signal-to-noise ratio)
- Single-supply operation from 2.5 V to 5.0 V
- 20 nA ultralow shutdown current
- Short-circuit and thermal protection
- Available in 8-lead, 3 mm \times 3 mm LFCSP and MSOP packages
- Pop-and-click suppression
- Built-in resistors reduce board component count
- Fixed and user-adjustable gain configurations

APPLICATIONS

- Mobile phones
- MP3 players
- Portable gaming
- Portable electronics
- Educational toys

GENERAL DESCRIPTION

The SSM2301 is a fully integrated, high efficiency, Class-D audio amplifier designed to maximize performance for mobile phone applications. The application circuit requires a minimum of external components and operates from a single 2.5 V to 5.0 V supply. It is capable of delivering 1.4 W of continuous output power with less than 1% THD + N driving an 8 Ω load from a 5.0 V supply.

The SSM2301 features a high efficiency, low noise modulation scheme that does not require external LC output filters. The modulation provides high efficiency even at low output power.

The SSM2301 operates with 85% efficiency at 1.4 W into 8 Ω from a 5.0 V supply and has a signal-to-noise ratio (SNR) that is greater than 98 dB. Spread-spectrum modulation is used to provide lower EMI-radiated emissions compared with other Class-D architectures.

The SSM2301 has a micropower shutdown mode with a maximum shutdown current of 30 nA. Shutdown is enabled by applying a logic low to the SD pin.

The device also includes pop-and-click suppression circuitry. This minimizes voltage glitches at the output during turn-on and turn-off, thus reducing audible noise on activation and deactivation.

The fully differential input of the SSM2301 provides excellent rejection of common-mode noise on the input. Input coupling capacitors can be omitted if the dc input common-mode voltage is approximately $V_{DD}/2$.

The SSM2301 also has excellent rejection of power supply noise, including noise caused by GSM transmission bursts and RF rectification. PSRR is typically 63 dB at 217 Hz.

The gain can be set to 6 dB or 12 dB by utilizing the gain control select pin connected respectively to ground or to VDD. Gain can also be adjusted externally by inserting a resistor in series with each input pin.

The SSM2301 is specified over the commercial temperature range (-40°C to $+85^{\circ}\text{C}$). It has built-in thermal shutdown and output short-circuit protection. It is available in both an 8-lead, 3 mm \times 3 mm lead-frame chip scale package (LFCSP) and an 8-lead MSOP package.

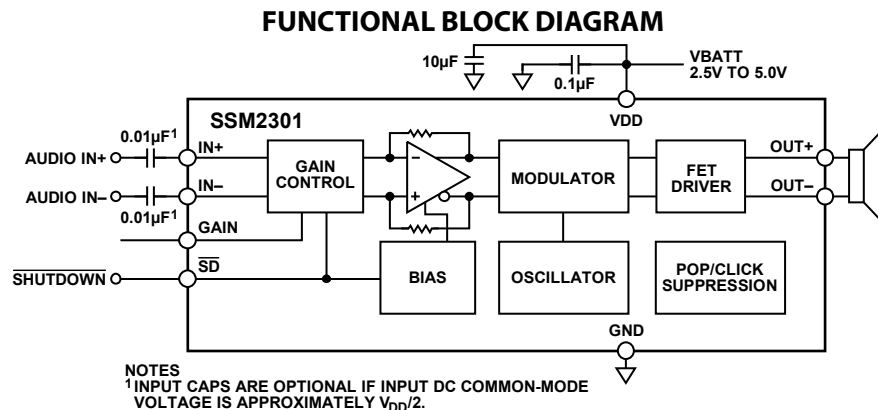

Figure 1.

Rev. A

Information furnished by Analog Devices is believed to be accurate and reliable. However, no responsibility is assumed by Analog Devices for its use, nor for any infringements of patents or other rights of third parties that may result from its use. Specifications subject to change without notice. No license is granted by implication or otherwise under any patent or patent rights of Analog Devices. Trademarks and registered trademarks are the property of their respective owners.

TABLE OF CONTENTS

Features	1	Typical Application Circuits	10
Applications.....	1	Applications Information	12
General Description	1	Overview	12
Functional Block Diagram	1	Gain Selection	12
Revision History	2	Pop-and-Click Suppression	12
Specifications.....	3	Layout	12
Absolute Maximum Ratings.....	4	Input Capacitor Selection.....	12
Thermal Resistance	4	Proper Power Supply Decoupling	13
ESD Caution.....	4	Outline Dimensions	14
Pin Configurations and Function Descriptions	5	Ordering Guide	14
Typical Performance Characteristics	6		

REVISION HISTORY

10/07—Rev. 0 to Rev. A

Added MSOP Package	Universal
Changes to Features.....	1
Changes to General Description	1
Changes to Table 1.....	3
Deleted Evaluation Board Information Section	14
Updated Outline Dimensions	14
Changes to Ordering Guide	14

1/07—Revision 0: Initial Version

SPECIFICATIONS

$V_{DD} = 5.0\text{ V}$, $T_A = 25^\circ\text{C}$, $R_L = 8\ \Omega + 33\ \mu\text{H}$, unless otherwise noted.

Table 1.

Parameter	Symbol	Conditions	Min	Typ	Max	Unit
DEVICE CHARACTERISTICS						
Output Power	P_O	$V_{DD} = 5.0\text{ V}$, $R_L = 8\ \Omega$, THD = 1% $f = 1\text{ kHz}$, 20 kHz BW		1.22		W
		$V_{DD} = 5.0\text{ V}$, $R_L = 8\ \Omega$, THD = 10% $f = 1\text{ kHz}$, 20 kHz BW		1.52		W
		$V_{DD} = 3.6\text{ V}$, $R_L = 8\ \Omega$, THD = 1% $f = 1\text{ kHz}$, 20 kHz BW		590		mW
		$V_{DD} = 3.6\text{ V}$, $R_L = 8\ \Omega$, THD = 10% $f = 1\text{ kHz}$, 20 kHz BW		775		mW
		$V_{DD} = 2.5\text{ V}$, $R_L = 8\ \Omega$, THD = 1% $f = 1\text{ kHz}$, 20 kHz BW		275		mW
		$V_{DD} = 2.5\text{ V}$, $R_L = 8\ \Omega$, THD = 10% $f = 1\text{ kHz}$, 20 kHz BW		345		mW
Efficiency	η	$P_{OUT} = 1.4\text{ W}$, $8\ \Omega$, $V_{DD} = 5.0\text{ V}$		85		%
Total Harmonic Distortion + Noise	THD + N	$P_O = 1\text{ W}$ into $8\ \Omega$, $f = 1\text{ kHz}$, $V_{DD} = 5.0\text{ V}$ $P_O = 0.5\text{ W}$ into $8\ \Omega$, $f = 1\text{ kHz}$, $V_{DD} = 3.6\text{ V}$		0.1 0.04		% %
Input Common-Mode Voltage Range	V_{CM}		1.0		$V_{DD} - 1.0$	V
Common-Mode Rejection Ratio	$CMRR_{GSM}$	$V_{CM} = 2.5\text{ V} \pm 100\text{ mV}$ at 217 Hz		55		dB
Average Switching Frequency	f_{SW}			1.8		MHz
Differential Output Offset Voltage	V_{OOS}	$G = 6\text{ dB}$; $G = 12\text{ dB}$		2.0		mV
POWER SUPPLY						
Supply Voltage Range	V_{DD}	Guaranteed from PSRR test	2.5		5.0	V
Power Supply Rejection Ratio	PSRR	$V_{DD} = 2.5\text{ V}$ to 5.0 V , dc input floating/ground	70	85		dB
	$PSRR_{GSM}$	$V_{RIPPLE} = 100\text{ mV}$ at 217 Hz, inputs are ac grounded, $C_{IN} = 0.01\ \mu\text{F}$, input referred		63		dB
Supply Current	I_{SY}	$V_{IN} = 0\text{ V}$, no load, $V_{DD} = 5.0\text{ V}$		4.2		mA
		$V_{IN} = 0\text{ V}$, no load, $V_{DD} = 3.6\text{ V}$		3.5		mA
		$V_{IN} = 0\text{ V}$, no load, $V_{DD} = 2.5\text{ V}$		2.9		mA
Shutdown Current	I_{SD}	$\overline{SD} = \text{GND}$		20		nA
GAIN CONTROL						
Closed-Loop Gain	A_{V0}	GAIN pin = 0 V		6		dB
	A_{V1}	GAIN pin = V_{DD}		12		dB
Differential Input Impedance	Z_{IN}	$\overline{SD} = V_{DD}$, $\overline{SD} = \text{GND}$		150 210		k Ω k Ω
SHUTDOWN CONTROL						
Input Voltage High	V_{IH}	$I_{SY} \geq 1\text{ mA}$		1.2		V
Input Voltage Low	V_{IL}	$I_{SY} \leq 300\text{ nA}$		0.5		V
Turn-On Time	t_{WU}	\overline{SD} rising edge from GND to V_{DD}		30		ms
Turn-Off Time	t_{SD}	\overline{SD} falling edge from V_{DD} to GND		5		μs
Output Impedance	Z_{OUT}	$\overline{SD} = \text{GND}$		>100		k Ω
NOISE PERFORMANCE						
Output Voltage Noise	e_n	$V_{DD} = 2.5\text{ V}$ to 5.0 V , $f = 20\text{ Hz}$ to 20 kHz , inputs are ac grounded, sine wave, $A_v = 6\text{ dB}$, A weighting		35		μV
Signal-to-Noise Ratio	SNR	$P_{OUT} = 1.4\text{ W}$, $R_L = 8\ \Omega$		98		dB

SSM2301

ABSOLUTE MAXIMUM RATINGS

Absolute maximum ratings apply at 25°C, unless otherwise noted.

Table 2.

Parameter	Rating
Supply Voltage	6 V
Input Voltage	V_{DD}
Common-Mode Input Voltage	V_{DD}
Storage Temperature Range	-65°C to +150°C
Operating Temperature Range	-40°C to +85°C
Junction Temperature Range	-65°C to +165°C
Lead Temperature (Soldering, 60 sec)	300°C

Stresses above those listed under Absolute Maximum Ratings may cause permanent damage to the device. This is a stress rating only; functional operation of the device at these or any other conditions above those indicated in the operational section of this specification is not implied. Exposure to absolute maximum rating conditions for extended periods may affect device reliability.

THERMAL RESISTANCE

θ_{JA} is specified for the worst-case conditions, that is, a device soldered in a circuit board for surface-mount packages.

Table 3. Thermal Resistance

Package Type	θ_{JA}	θ_{JC}	Unit
8-lead, 3 mm × 3 mm LFCSP	62	20.8	°C/W
8-lead MSOP	210	45	°C/W

ESD CAUTION



ESD (electrostatic discharge) sensitive device. Charged devices and circuit boards can discharge without detection. Although this product features patented or proprietary protection circuitry, damage may occur on devices subjected to high energy ESD. Therefore, proper ESD precautions should be taken to avoid performance degradation or loss of functionality.

PIN CONFIGURATIONS AND FUNCTION DESCRIPTIONS

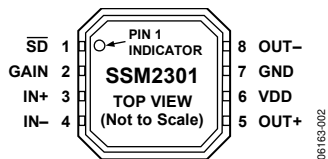

Figure 2. LFCSP Pin Configuration

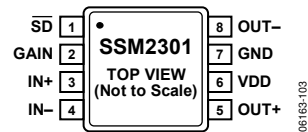

Figure 3. MSOP Pin Configuration

Table 4. Pin Function Descriptions

Pin No.	Mnemonic	Description
1	SD	Shutdown Input. Active low digital input.
2	GAIN	Gain Selection. Digital input.
3	IN+	Noninverting Input.
4	IN-	Inverting Input.
5	OUT+	Noninverting Output.
6	VDD	Power Supply.
7	GND	Ground.
8	OUT-	Inverting Output.

TYPICAL PERFORMANCE CHARACTERISTICS

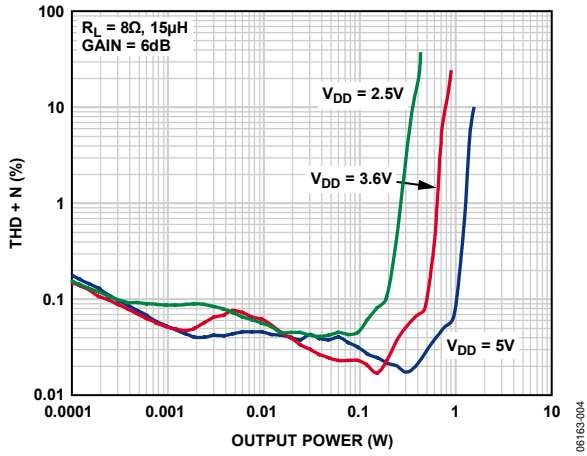

Figure 4. THD + N vs. Output Power into 8 Ω , $A_V = 6$ dB

06163-004

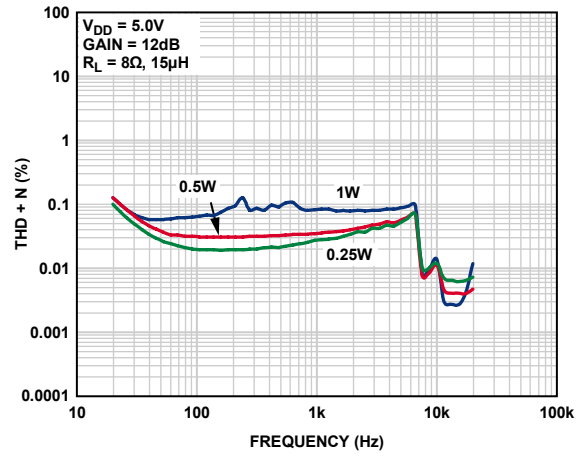

Figure 7. THD + N vs. Frequency, $V_{DD} = 5.0$ V, $A_V = 12$ dB, $R_L = 8$ Ω

06163-008

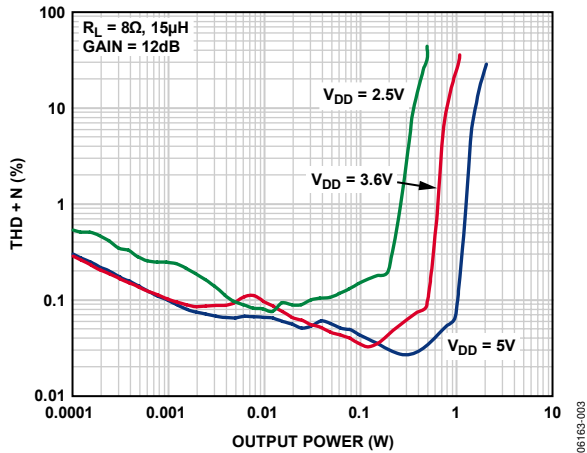

Figure 5. THD + N vs. Output Power into 8 Ω , $A_V = 12$ dB

06163-003

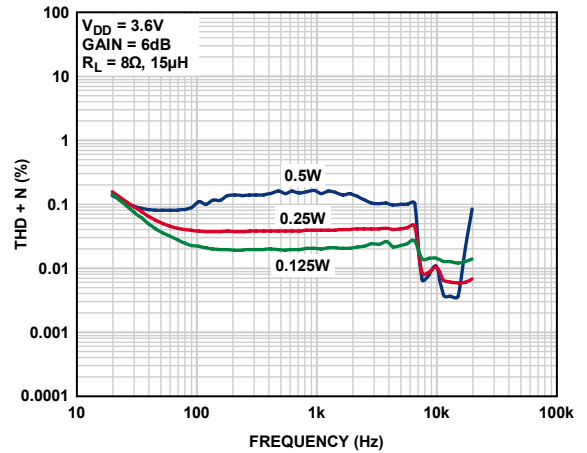

Figure 8. THD + N vs. Frequency, $V_{DD} = 3.6$ V, $A_V = 6$ dB, $R_L = 8$ Ω

06163-009

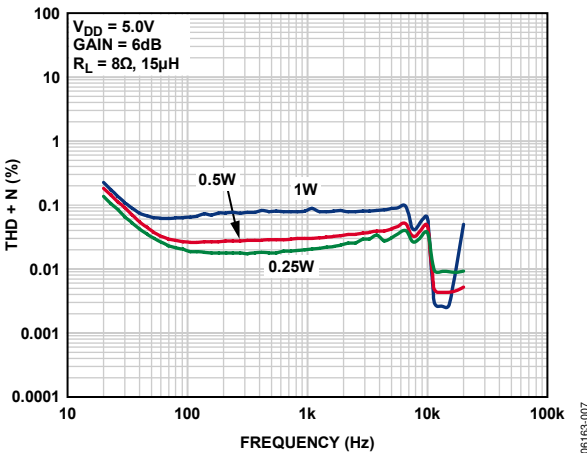

Figure 6. THD + N vs. Frequency, $V_{DD} = 5.0$ V, $A_V = 6$ dB, $R_L = 8$ Ω

06163-007

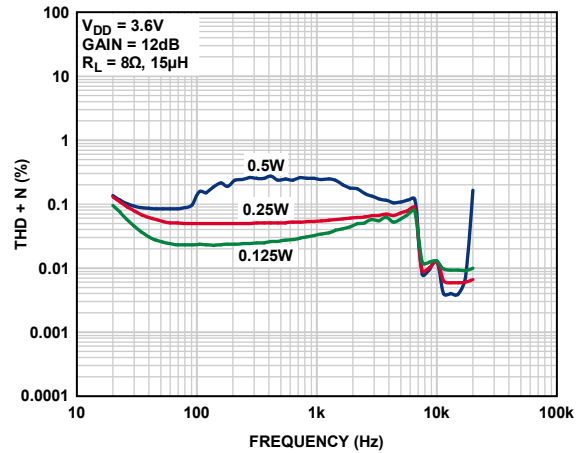

Figure 9. THD + N vs. Frequency, $V_{DD} = 3.6$ V, $A_V = 12$ dB, $R_L = 8$ Ω

06163-010

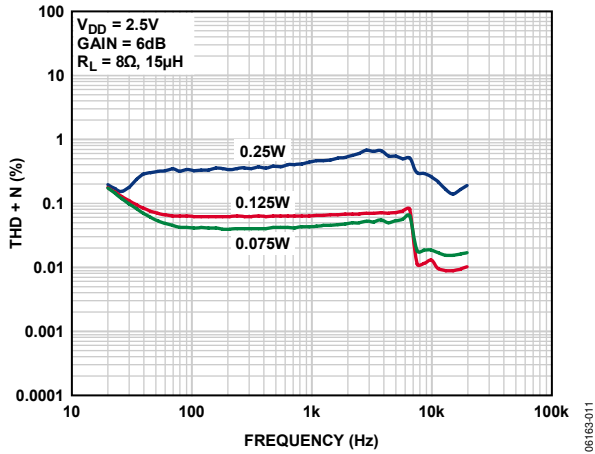

Figure 10. THD + N vs. Frequency, $V_{DD} = 2.5\text{ V}$, $A_v = 6\text{ dB}$, $R_L = 8\ \Omega$

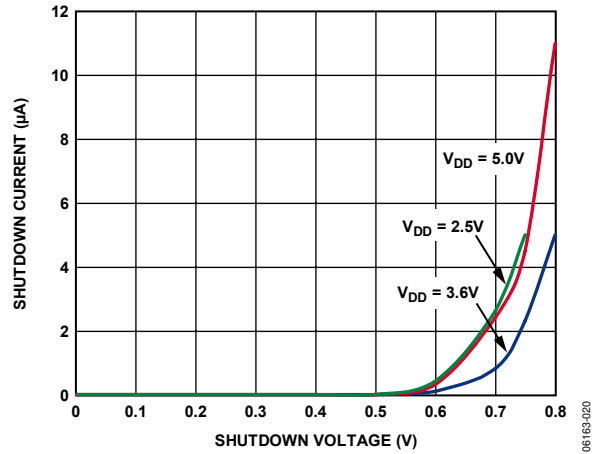

Figure 13. Shutdown Current vs. Shutdown Voltage

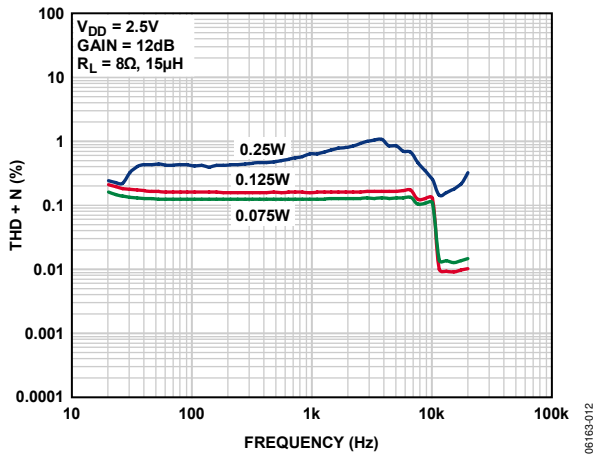

Figure 11. THD + N vs. Frequency, $V_{DD} = 2.5\text{ V}$, $A_v = 12\text{ dB}$, $R_L = 8\ \Omega$

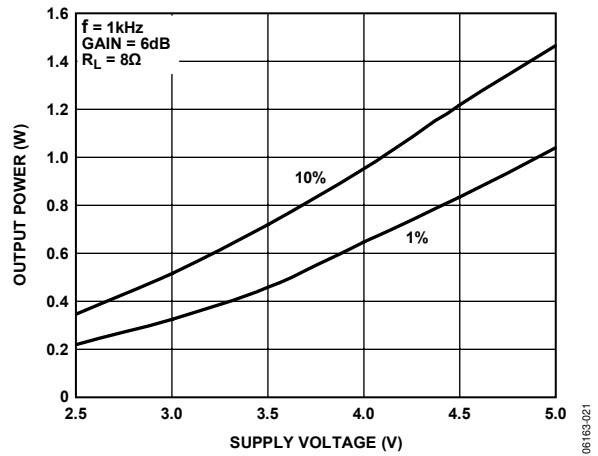

Figure 14. Maximum Output Power vs. Supply Voltage, $A_v = 6\text{ dB}$, $R_L = 8\ \Omega$

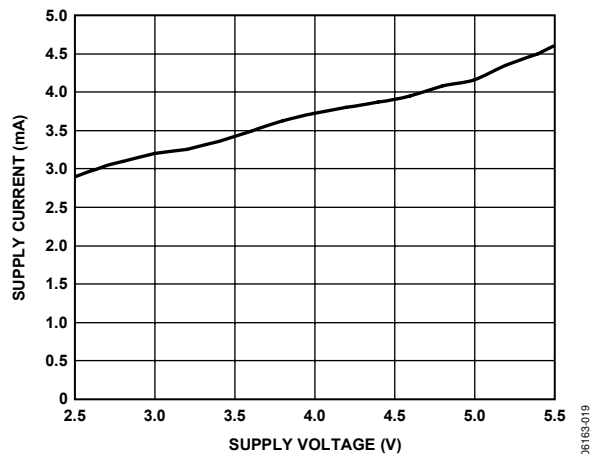

Figure 12. Supply Current vs. Supply Voltage, No Load

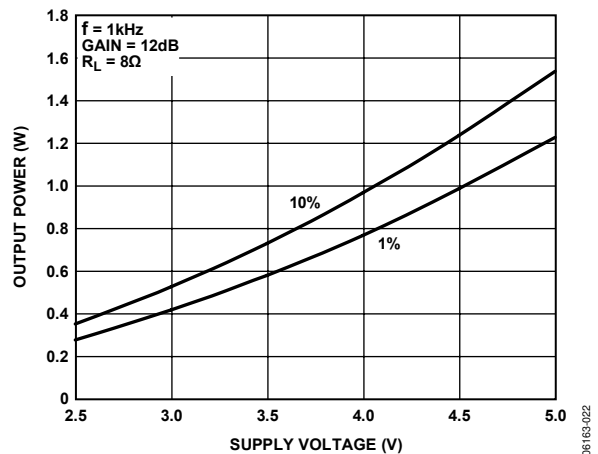

Figure 15. Maximum Output Power vs. Supply Voltage, $A_v = 12\text{ dB}$, $R_L = 8\ \Omega$

SSM2301

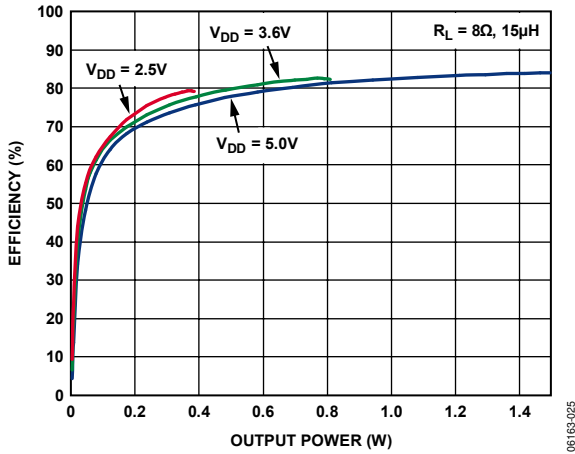

Figure 16. Efficiency vs. Output Power into 8Ω

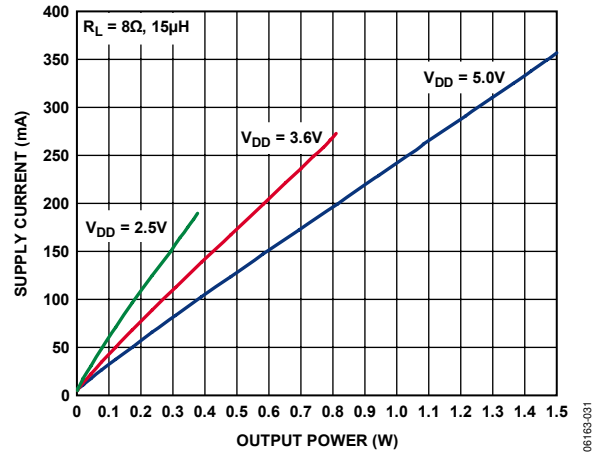

Figure 19. Supply Current vs. Output Power into 8Ω, One Channel

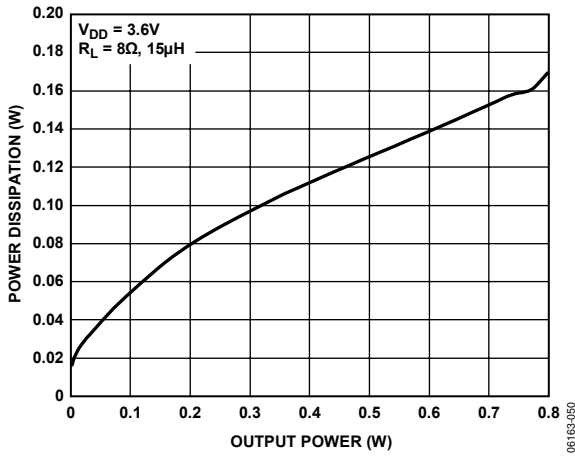

Figure 17. Power Dissipation vs. Output Power into 8Ω at $V_{DD} = 3.6V$

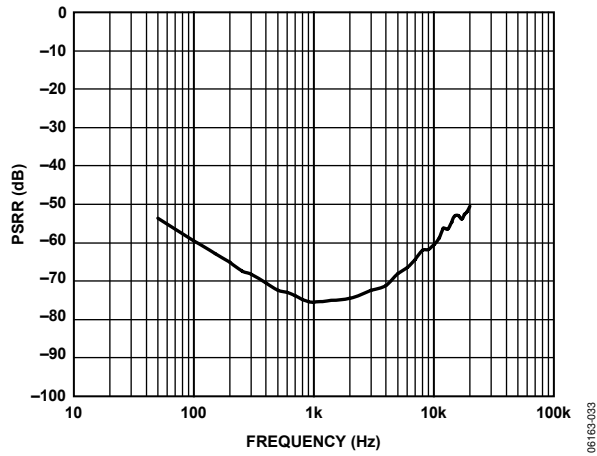

Figure 20. Power Supply Rejection Ratio vs. Frequency

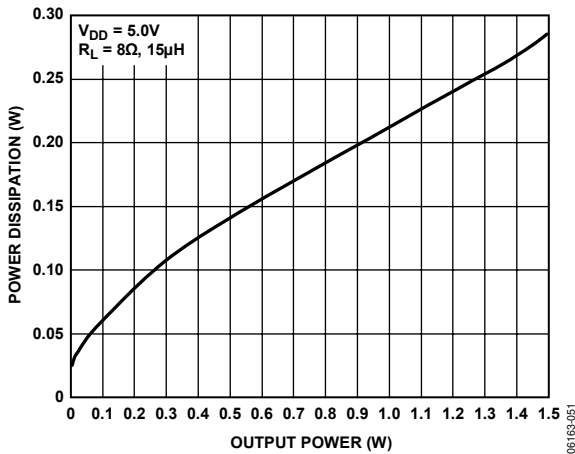

Figure 18. Power Dissipation vs. Output Power into 8Ω at $V_{DD} = 5.0V$

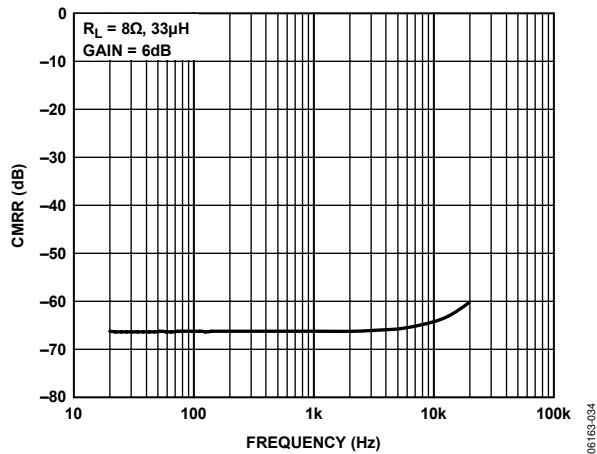

Figure 21. Common-Mode Rejection Ratio vs. Frequency

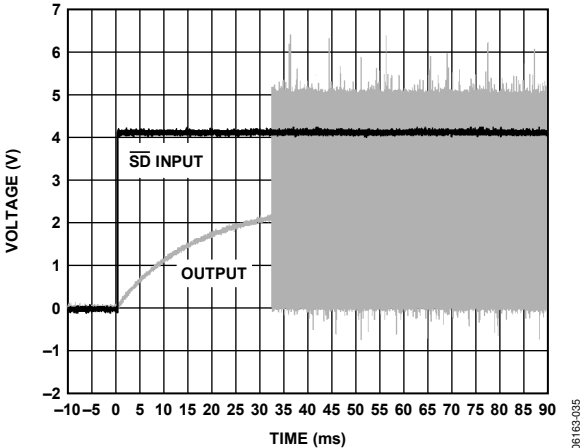

Figure 22. Turn-On Response

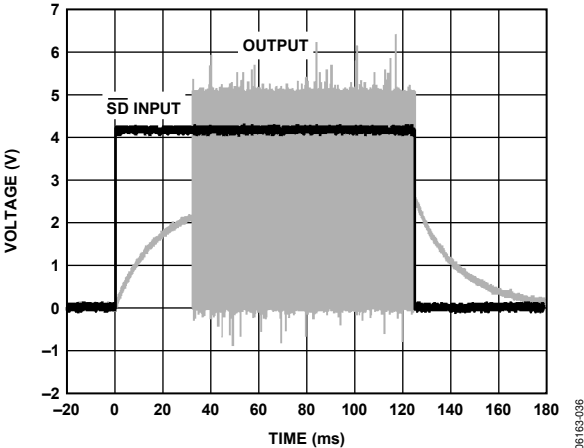
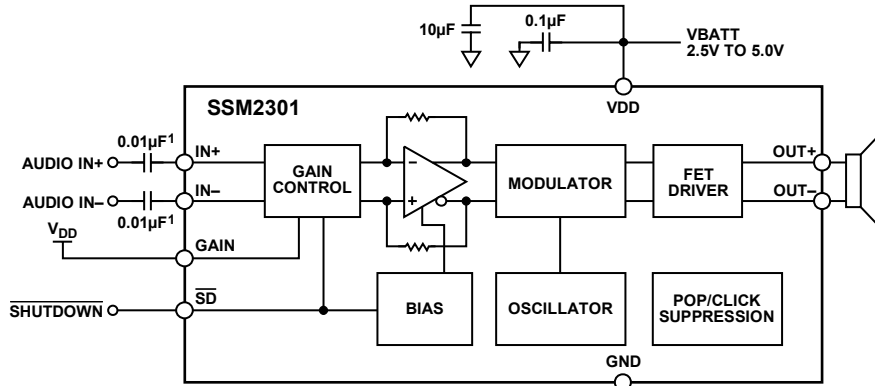

Figure 23. Turn-Off Response

TYPICAL APPLICATION CIRCUITS



NOTES
¹INPUT CAPACITORS ARE OPTIONAL IF INPUT DC COMMON-MODE VOLTAGE IS APPROXIMATELY $V_{DD}/2$.

Figure 24. Differential Input Configuration, Gain = 12 dB

06163-037

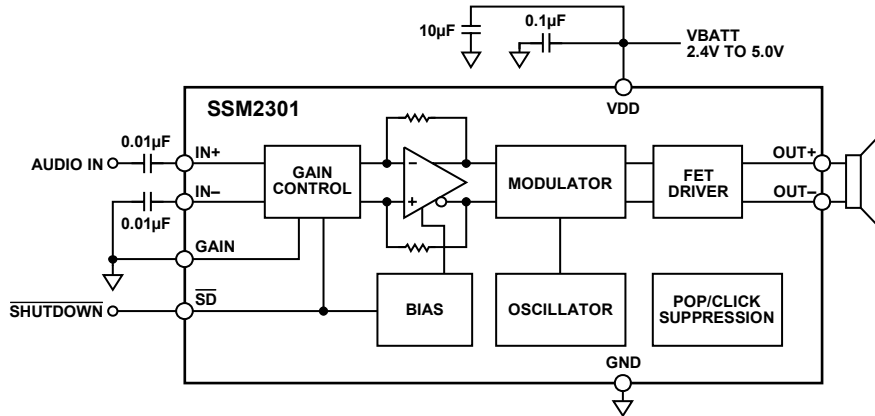
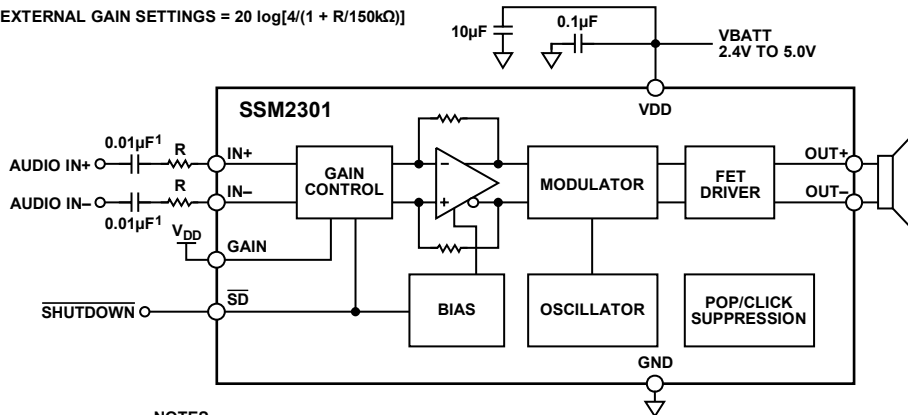

Figure 25. Single-Ended Input Configuration, Gain = 6 dB

06163-038

EXTERNAL GAIN SETTINGS = $20 \log[4/(1 + R/150k\Omega)]$



NOTES
¹INPUT CAPACITORS ARE OPTIONAL IF INPUT DC COMMON-MODE VOLTAGE IS APPROXIMATELY $V_{DD}/2$.

Figure 26. Differential Input Configuration, User-Adjustable Gain

06163-039

EXTERNAL GAIN SETTINGS = $20 \log[4/(1 + R/150k\Omega)]$

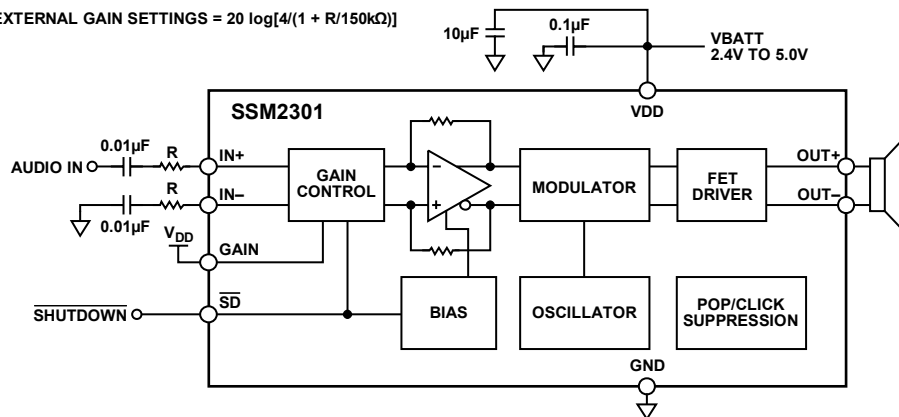

06163-040

Figure 27. Single-Ended Input Configuration, User-Adjustable Gain

EXTERNAL GAIN SETTINGS = $20 \log[2/(1 + R/150k\Omega)]$

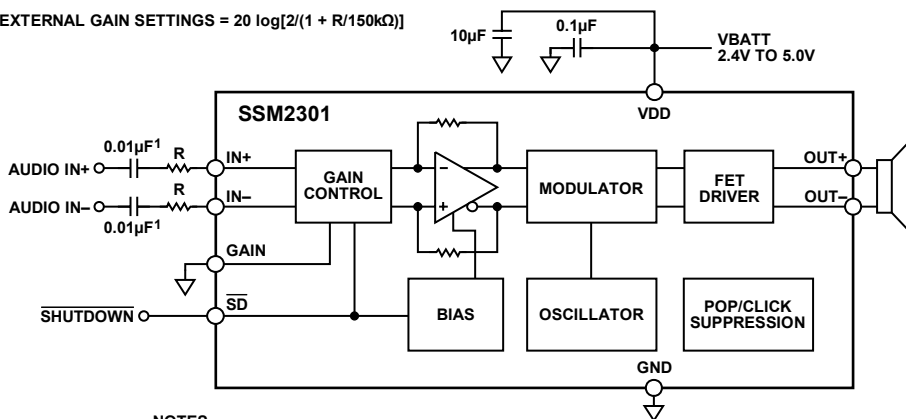

06163-041

NOTES
¹ INPUT CAPACITORS ARE OPTIONAL IF INPUT DC COMMON-MODE VOLTAGE IS APPROXIMATELY $V_{DD}/2$.

Figure 28. Differential Input Configuration, User-Adjustable Gain

EXTERNAL GAIN SETTINGS = $20 \log[2/(1 + R/150k\Omega)]$

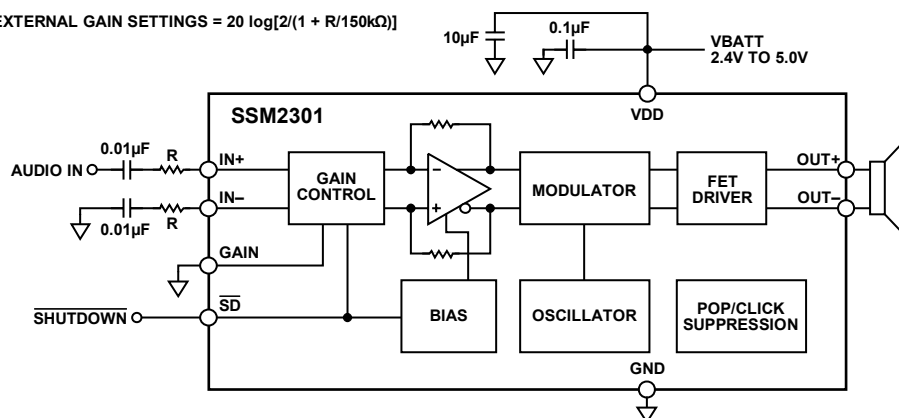

06163-042

Figure 29. Single-Ended Input Configuration, User-Adjustable Gain

APPLICATIONS INFORMATION

OVERVIEW

The SSM2301 mono Class-D audio amplifier features a filterless modulation scheme that greatly reduces external component count, conserving board space and, thus, reducing system cost. The SSM2301 does not require an output filter but, instead, relies on the inherent inductance of the speaker coil and the natural filtering of the speaker and human ear to fully recover the audio component of the square-wave output. While most Class-D amplifiers use some variation of pulse-width modulation (PWM), the SSM2301 uses a Σ - Δ modulation to determine the switching pattern of the output devices. This provides a number of important benefits. Σ - Δ modulators do not produce a sharp peak with many harmonics in the AM frequency band, as pulse-width modulators often do. Σ - Δ modulation reduces the amplitude of spectral components at high frequencies, thereby reducing EMI emission that might otherwise be radiated by speakers and long cable traces. The SSM2301 also offers protection circuitry for output short-circuit and high temperature conditions. When the fault-inducing condition is removed, the SSM2301 automatically recovers without the need for a hard reset.

GAIN SELECTION

Pulling the GAIN pin of the SSM2301 high sets the gain of the speaker amplifier to 12 dB; pulling it low sets the gain of the speaker amplifier to 6 dB.

It is possible to adjust the SSM2301 gain by using external resistors at the input. To set a gain lower than 12 dB, see Figure 26 for differential input configuration and Figure 27 for single-ended configuration. For external gain configuration from a fixed 12 dB gain, use the following formula:

$$\text{External Gain Settings} = 20 \log[4/(1 + R/150 \text{ k}\Omega)]$$

To set a gain lower than 6 dB, see Figure 28 for differential input configuration and Figure 29 for single-ended configuration. For external gain configuration from a fixed 6 dB gain, use the following formula:

$$\text{External Gain Settings} = 20 \log[2/(1 + R/150 \text{ k}\Omega)]$$

POP-AND-CLICK SUPPRESSION

Voltage transients at the output of audio amplifiers may occur when shutdown is activated or deactivated. Voltage transients as low as 10 mV can be heard as an audio pop in the speaker. Clicks and pops can also be classified as undesirable audible transients generated by the amplifier system and, therefore, as not coming from the system input signal. Such transients may be generated when the amplifier system changes its operating mode. For example, the following can be sources of audible transients: system power-up/power-down, mute/unmute, input source change, and sample rate change. The SSM2301 has a pop-and-click suppression architecture that reduces these output transients, resulting in noiseless activation and deactivation.

LAYOUT

As output power continues to increase, care must be taken to lay out PCB traces and wires properly between the amplifier, load, and power supply. A good practice is to use short, wide PCB tracks to decrease voltage drops and minimize inductance. Make track widths at least 200 mil for every inch of track length for lowest DCR, and use 1 oz or 2 oz of copper PCB traces to further reduce IR drops and inductance.

Poor layout increases voltage drops, consequently affecting efficiency. Use large traces for the power supply inputs and amplifier outputs to minimize losses due to parasitic trace resistance. Proper grounding guidelines help improve audio performance, minimize crosstalk between channels, and prevent switching noise from coupling into the audio signal. To maintain high output swing and high peak output power, PCB traces that connect the output pins to the load and supply pins should be as wide as possible to maintain the minimum trace resistances.

It is also recommended that a large-area ground plane be used for minimum impedances. Good PCB layouts also isolate critical analog paths from sources of high interference. High frequency circuits (analog and digital) should be separated from low frequency circuits. Properly designed multilayer printed circuit boards can reduce EMI emission and increase immunity to the RF field by a factor of 10 or more compared with double-sided boards. A multilayer board allows a complete layer to be used for the ground plane, whereas the ground plane side of a double-side board is often disrupted with signal crossover. If the system has separate analog and digital ground and power planes, the analog ground plane should be underneath the analog power plane, and, similarly, the digital ground plane should be underneath the digital power plane. There should be no overlap between analog and digital ground planes or analog and digital power planes.

INPUT CAPACITOR SELECTION

The SSM2301 does not require input coupling capacitors if the input signal is biased from 1.0 V to $V_{DD} - 1.0$ V. Input capacitors are required if the input signal is not biased within this recommended input dc common-mode voltage range, if high-pass filtering is needed (see Figure 24) or if using a single-ended source (see Figure 25). If high-pass filtering is needed at the input, the input capacitor, along with the input resistor of the SSM2301, forms a high-pass filter whose corner frequency is determined by the following equation:

$$f_c = 1/(2\pi \times R_{IN} \times C_{IN})$$

The input capacitor can have very important effects on the circuit performance. Not using input capacitors degrades the output offset of the amplifier as well as the PSRR performance.

PROPER POWER SUPPLY DECOUPLING

To ensure high efficiency, low total harmonic distortion (THD), and high PSRR, proper power supply decoupling is necessary. Noise transients on the power supply lines are short-duration voltage spikes. Although the actual switching frequency can range from 10 kHz to 100 kHz, these spikes can contain frequency components that extend into the hundreds of megahertz.

The power supply input needs to be decoupled with a good quality low ESL and low ESR capacitor, usually around 4.7 μF . This capacitor bypasses low frequency noises to the ground plane. For high frequency transients noises, use a 0.1 μF capacitor placed as close as possible to the VDD pin of the device. Placing the decoupling capacitor as close as possible to the SSM2301 helps maintain efficient performance.

OUTLINE DIMENSIONS

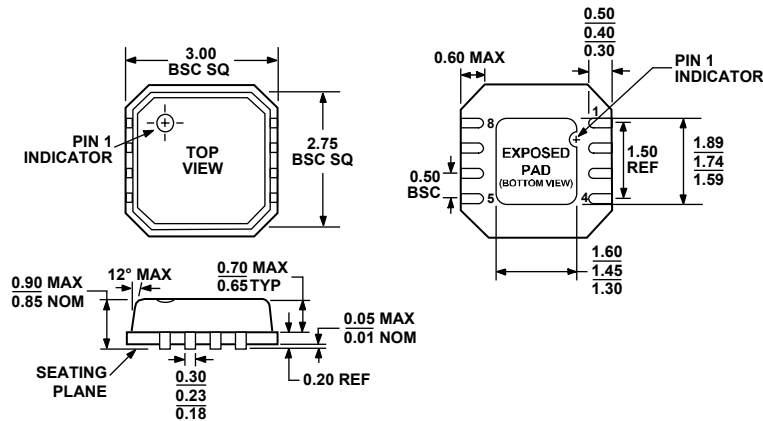
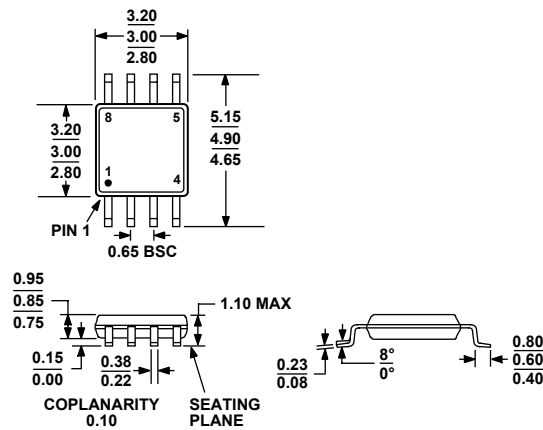

Figure 30. 8-Lead Lead Frame Chip Scale Package [LFCSP_VD]
3 mm × 3 mm Body, Very Thin, Dual Lead
(CP-8-2)
Dimensions shown in millimeters



COMPLIANT TO JEDEC STANDARDS MO-187-AA
Figure 31. 8-Lead Mini Small Outline Package [MSOP]
(RM-8)
Dimensions shown in millimeters

ORDERING GUIDE

Model	Temperature Range	Package Description	Package Option	Branding
SSM2301CPZ-R2 ¹	-40°C to +85°C	8-Lead Lead Frame Chip Scale Package [LFCSP_VD]	CP-8-2	A1C
SSM2301CPZ-REEL ¹	-40°C to +85°C	8-Lead Lead Frame Chip Scale Package [LFCSP_VD]	CP-8-2	A1C
SSM2301CPZ-REEL7 ¹	-40°C to +85°C	8-Lead Lead Frame Chip Scale Package [LFCSP_VD]	CP-8-2	A1C
SSM2301RMZ-R2 ¹	-40°C to +85°C	8-Lead Mini Small Outline Package [MSOP]	RM-8	A1C
SSM2301RMZ-REEL ¹	-40°C to +85°C	8-Lead Mini Small Outline Package [MSOP]	RM-8	A1C
SSM2301RMZ-REEL7 ¹	-40°C to +85°C	8-Lead Mini Small Outline Package [MSOP]	RM-8	A1C
SSM2301-EVALZ ¹		Evaluation Board with LFCSP Model		

¹ Z = RoHS Compliant Part.

NOTES

SSM2301

NOTES