

## Data Sheet

### Description

These Precision Optical Performance Oval LEDs are specially designed for full color/video and passenger information signs. The oval shaped radiation pattern and high luminous intensity ensure that these devices are excellent for wide field of view outdoor application where a wide viewing angle and readability in sunlight are essential. These lamps have very smooth, matched radiation patterns ensuring consistent color mixing in full color application, message uniformity across the viewing angle of the sign. High efficiency LED material is used in these lamps: Aluminum Indium Gallium Phosphide (AlInGaP) for amber and red. Each lamp is made with an advance optical grade epoxy offering superior high temperature and high moisture resistance in outdoor applications. The package epoxy contains both UV-A and UV-B inhibitors to reduce the effects of long term exposure to direct sunlight.

### Applications

- Traffic management:
  - Traffic Signals
  - Pedestrian signals
  - Work Zone Warning Lights
  - Variable Message Signs
- Commercial Outdoor advertising
  - Sign
  - Marquees

### Features

- High Luminous Output
- Well defined spatial radiation pattern
- Viewing angles:

	<b>30 x 70</b>
Major axis	70
Minor axis	30

- Red and Amber Intensity are available for AlInGaP
- Colors:
  - 626 nm red
  - 592 nm amber
- Superior resistance to moisture
- UV resistant epoxy
- Package
  - With or Without lead stand-Offs

### Benefits

- Viewing Angle match Traffic Management Sign Requirements
- Colors Meet Pedestrian Signal Specifications
- Superior performance In Outdoor and Indoor Environments
- Suitable for Auto-insertion onto PC Boards
- Suitable for high current application which give good sign contrast and reduce the number of LED use in a cluster

### Package Dimensions A

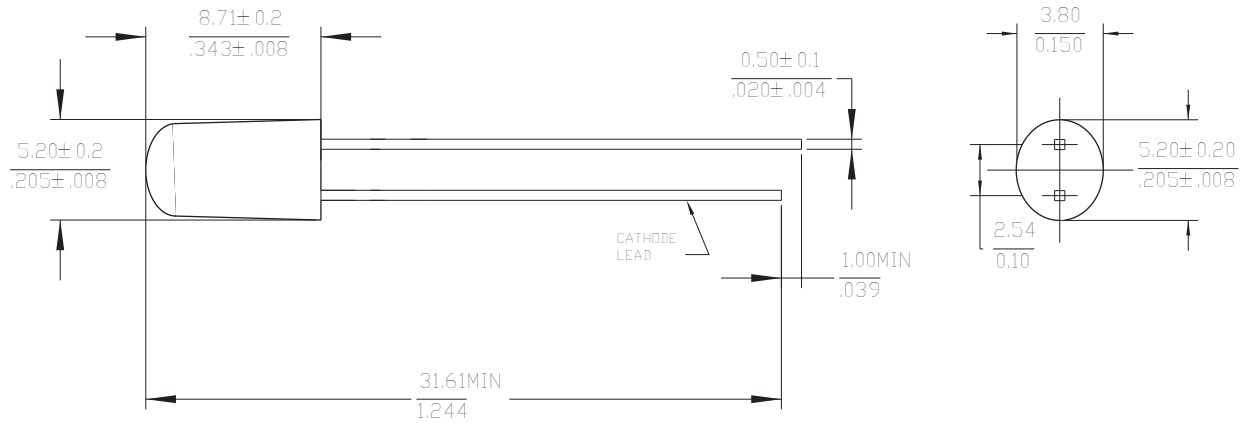

### Package Dimensions B

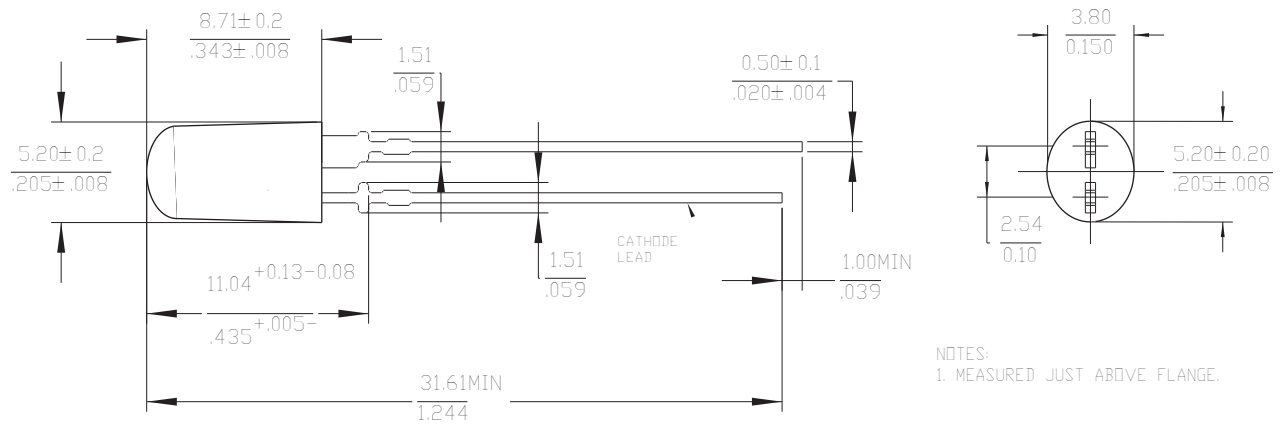

NOTES:  
1. MEASURED JUST ABOVE FLANGE.

#### Notes:

1. Dimension in millimeters (inches)
2. Tolerance  $\pm 0.1$  mm unless otherwise noted.

Part Number	Standoff Leads	Color and Dominant Wavelength (nm). Typ. [3]	Luminous Intensity $I_v$ (mcd) [1,2] @70 mA			Package Drawing
			Min.	Typ.	Max.	
HLMP-AD30-UX000	No	Red/626	3200	6053	9300	A
HLMP-AD31-UX000	Yes	Red/626	3200	6053	9300	B
HLMP-AL30-TW000	No	Amber/592	2500	3920	7200	A
HLMP-AL31-TW000	Yes	Amber/592	2500	3920	7200	B

#### Notes:

1. The luminous Intensity is measured on the axis of the lamps packages.
2. The optical axis is closely aligned with the package mechanical axis.
3. The dominant wavelength,  $\lambda_d$ , is derive from the CIE Chromaticity Diagram and represents the color of the lamps.
4.  $\theta_{1/2}$  is the off-axis angle where the luminous intensity is one half the on-axis intensity.

## Part Numbering System

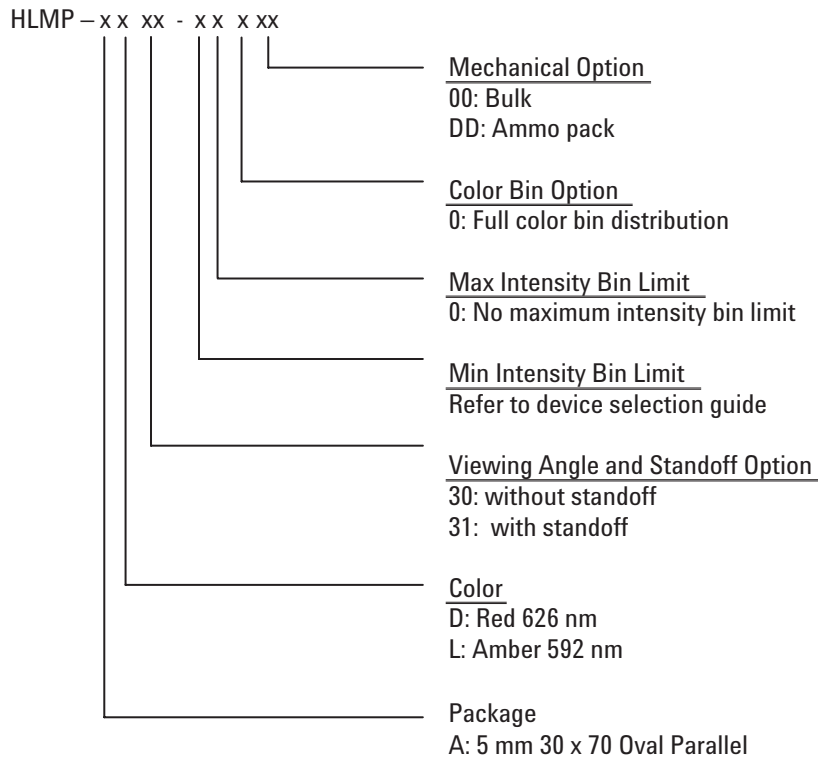

## Absolute Maximum Rating (TA = 25°C)

Parameters	Value
DC forward current <sup>[1]</sup>	70 mA
Peak pulsed forward current	100 mA
Average forward current	70 mA
Reverse voltage (I <sub>r</sub> = 100 A)	5 V
LED junction temperature	130 C
Operating temperature	-40 C to +100 C
Storage temperature	-40 C to +120 C
Wave soldering temperature <sup>[2]</sup>	250 C for 3 seconds
Solder Dipping Temperature <sup>[2]</sup>	260°C for 5 seconds

Note:

- Derate linearly as shown in figure 4.
- 1.59 mm (0.060 in.) below body

### Electrical and Optical Characteristics at TA=25°C

Parameters	Min	Typ	Max	Unit	Test Condition
Forward voltage					
Amber ( $\lambda_d=592$ nm)		2.10	2.45	V	$I_F = 70$ mA
Red ( $\lambda_d=626$ nm)		2.84	3.25		
Reverse voltage	5	20		V	$I_F = 100$ $\mu$ A
Peak Wavelength:					
Amber ( $\lambda_d=592$ nm)		595		nm	$I_F = 70$ mA
Red ( $\lambda_d=626$ nm)		638			
Spectral Halfwidth					
Amber ( $\lambda_d=592$ nm)		16		nm	$I_F = 70$ mA
Red ( $\lambda_d=626$ nm)		20			
Capacitance					
Amber ( $\lambda_d=592$ nm)		17		pF	$V_f=0$ , $f=1$ MHz
Red ( $\lambda_d=626$ nm)		34			
Thermal Resistance		130		$^{\circ}$ C/W	LED Junction to cathode
Luminous Efficacy[1]					
Amber ( $\lambda_d=592$ nm)		800		lm/W	Emitted Luminous
Red ( $\lambda_d=626$ nm)		970			Power/ Emitted Radiant power

Note:

1. The radiant intensity,  $I_e$  in watts per steradian, may be found from the equation  $I_e=I_v/h_v$ , where  $I_v$  is the luminous intensity in candelas and  $h_v$  is the luminous efficacy in lumens/watt.

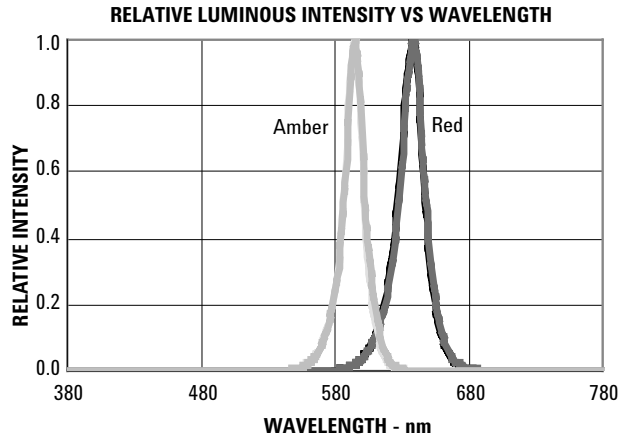

Figure 1. Relative Intensity vs. Wavelength

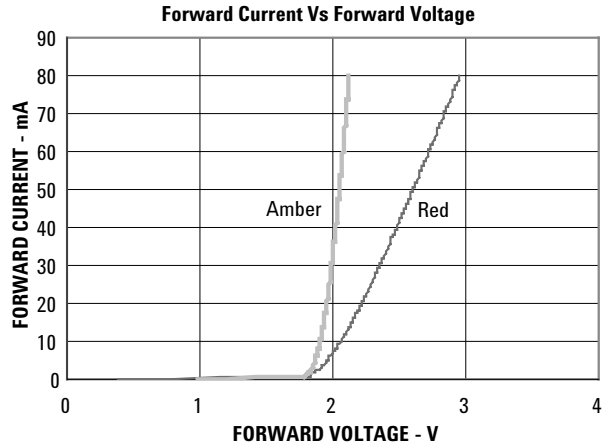

Figure 2. Forward Current vs. Forward Voltage

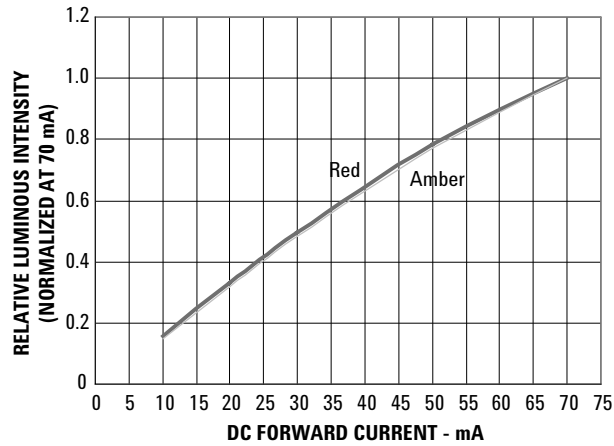

Figure 3. Relative Luminous Intensity vs. Forward Current

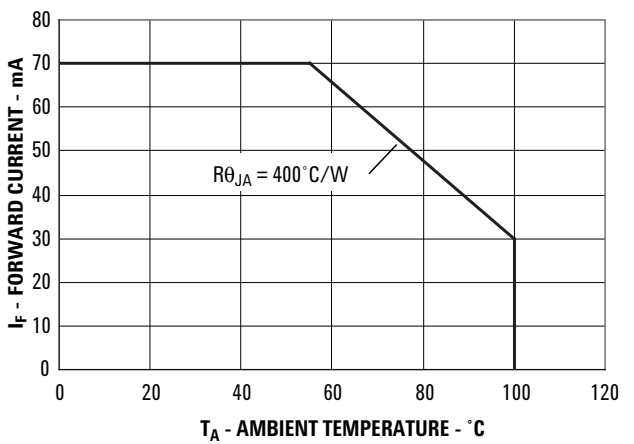

Figure 4. Maximum Forward Current vs. Ambient Temperature. Derating Based on  $T_{JMAX}=130^{\circ}C$ .

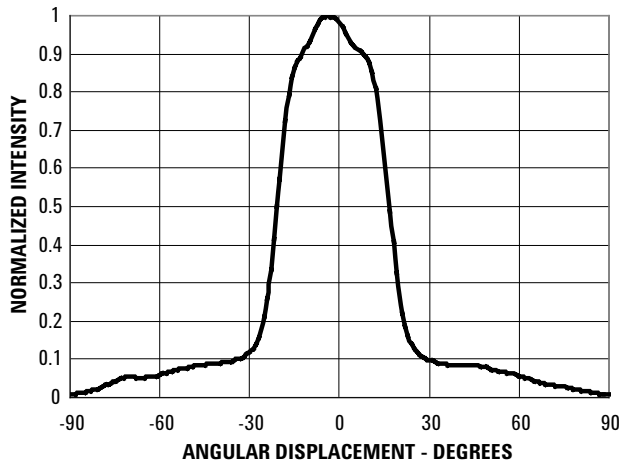

Figure 5. Representative Spatial Radiation Pattern of the — minor axis

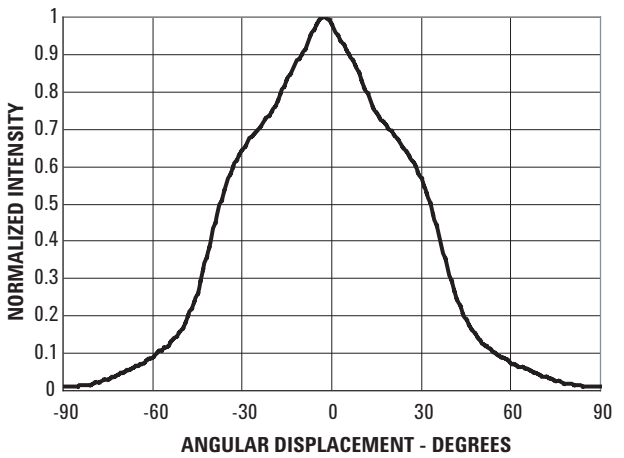

Figure 6. Representative Spatial Radiation Pattern for the — major axis

**Intensity Bin Limits  
(mcd at 70 mA)**

Bin Name	Min.	Max.
S	1900	2500
T	2500	3200
U	3200	4200
V	4200	5500
W	5500	7200
X	7200	9300

Tolerance for each bin limits is  $\pm 15\%$

**Amber color Bin Limits  
(nm at 70 mA)**

Bin Name	Min.	Max.	Corner Point	1	2	3	4
1	584.5	587.0	x	0.542	0.537	0.553	0.557
			y	0.458	0.455	0.440	0.442
2	587.0	589.5	x	0.557	0.553	0.567	0.572
			y	0.442	0.440	0.425	0.427
4	589.5	592.0	x	0.572	0.567	0.582	0.587
			y	0.427	0.425	0.411	0.413
6	592.0	594.5	x	0.587	0.582	0.595	0.600
			y	0.413	0.411	0.398	0.399

Tolerance for each bin limits is  $\pm 0.5\text{nm}$

For product information and a complete list of distributors, please go to our web site: [www.avagotech.com](http://www.avagotech.com)

Avago, Avago Technologies, and the A logo are trademarks of Avago Technologies, Limited in the United States and other countries.  
Data subject to change. Copyright © 2006 Avago Technologies Pte. All rights reserved.  
5989-3988EN - May 9, 2006

