

# RJ45 Jack, Right Angle, Tab Down, Shielded, Low Profile, 8P8C

ARJ014-011157

RoHS/RoHS II Compliant



15.74 x 11.75 x 18.65mm

## FEATURES:

- 8P8C standard DIP Jack
- Compliant with IEEE802.3 standard
- High performance for maximum EMI suppression
- High reliability 750 mating/unmating cycles

## APPLICATIONS:

- Designed for most leading PHY IC manufacturers such as Broadcom, Marvell, Microsemi.
- Side entry with wide temperature range(-40°C~85°C)
- Applicable for Ethernet Switch, Servers, & Access Point Routers

## STANDARD SPECIFICATIONS

Operating temperature range: -40°C to +85°C Storage temperature range: -40°C to +85°C

### Standard Electrical Specifications

Voltage Rating: 125 Vac RMS  
Current Rating: 1.5 Amp  
Contact Resistance: 40 mΩ Max  
Insulation resistance: 1000 MΩ Min @500 Vdc  
Dielectric strength: 1000Vac RMS @50 or 60Hz, 1Min

### Standard Mechanical Specifications

Mating/Unmating force: 2.2kgF max  
Retention strength: 7.7kgF min between jack and plug  
Operating life: 750 cycles min

## MECHANICAL DIMENSIONS

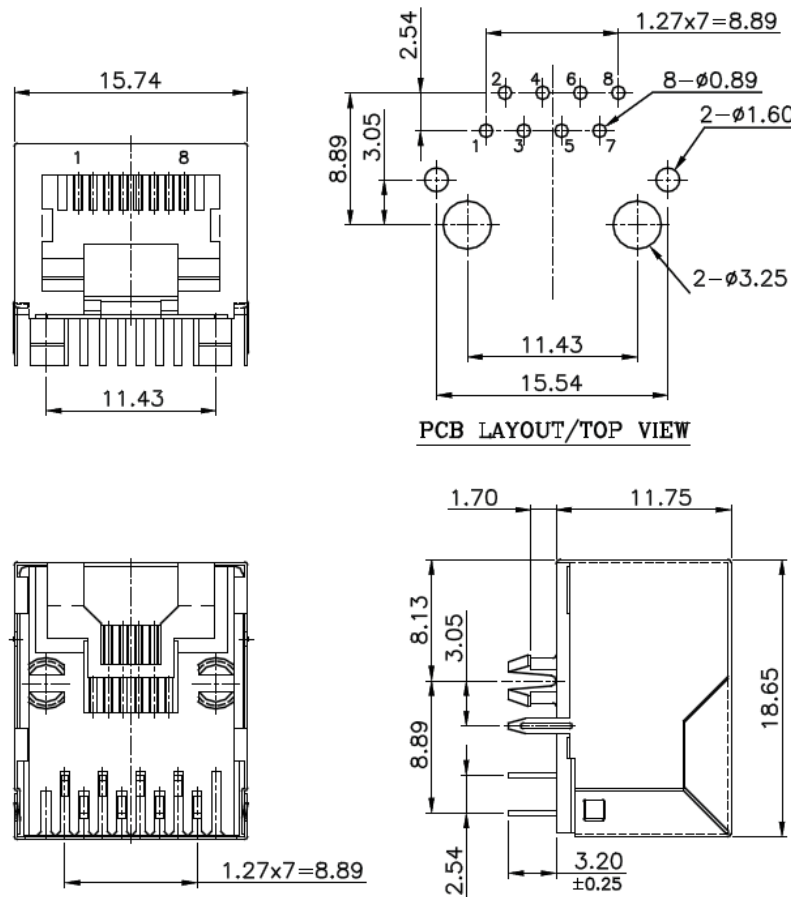

Dimensions: mm

# RJ45 Jack, Right Angle, Tab Down, Shielded, Low Profile, 8P8C

ARJ014-011157

RoHS/RoHS II Compliant



15.74 x 11.75 x 18.65mm

## DIP WAVE SOLDERING CURVE

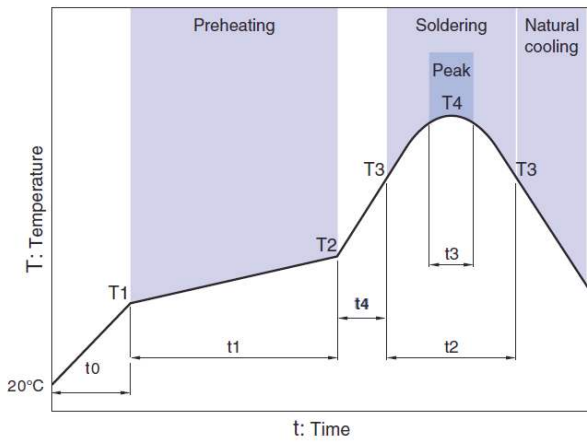

Preheating				Soldering				Peak	
Temp.	T2	t0	t1	Temp.	T2	t2	T4	t3	
100°C	150°C	30 to 60s	30 to 120s	30 to 60s	200°C	30s	230°C	5s	

Profile Feature	Pb-Free Assembly
Preheat	
-Temperature Min	100°C
-Temperature Max	200°C
-Time (min to max)	60-120 seconds
Time maintained above:	
-Temperature	200°C
-Time	30 seconds
Peak/Classification Temperature	230±5°C
Time within 230±5°C of actual Peak Temperature	5 seconds
Time 25°C to Peak Temperature	4 minutes 30 sec. max.

## PACKAGING:

**Packing:** (90pcs/tray) **MOQ:** 540pcs  
**Weight:** 4.02 grams/pcs

**Packaging material:** PET

**Outer carton unit(optional):**2340pcs/ 26trays/box,  
**Gross Weight:** 11.0kg

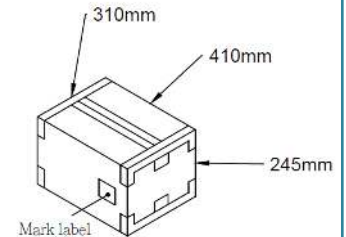
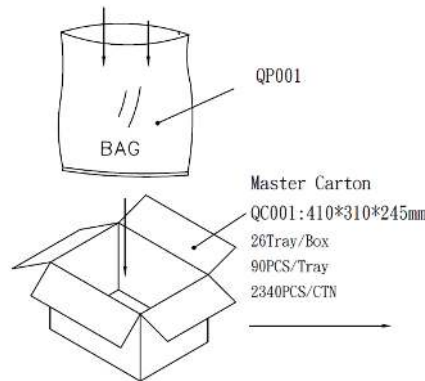
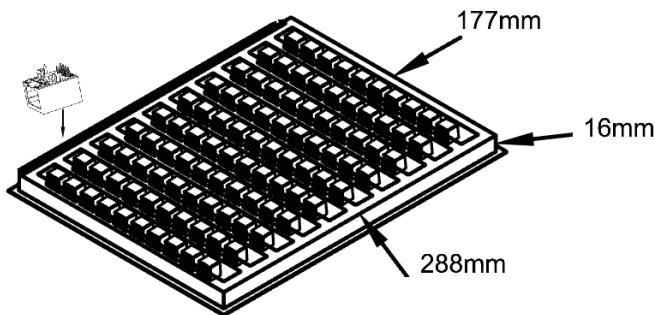

**Dimensions: mm**

**ATTENTION:** Abracon Corporation's products are COTS – Commercial-Off-The-Shelf products; suitable for Commercial, Industrial and, where designated, Automotive Applications. Abracon's products are not specifically designed for Military, Aviation, Aerospace, Life-dependant Medical applications or any application requiring high reliability where component failure could result in loss of life and/or property. For applications requiring high reliability and/or presenting an extreme operating environment, written consent and authorization from Abracon Corporation is required. Please contact Abracon Corporation for more information.

ABRACON IS  
 ISO 9001:2008  
 CERTIFIED



2 Faraday, Suite# B | Irvine | CA 92618 **Revised: 11.17.15**  
 Ph. 949.546.8000 | Fax. 949.546.8001  
 Visit [www.abracon.com](http://www.abracon.com) for Terms and Conditions of Sale