

| PART NUMBER | REV | FIRST USED |
|-------------|-----|------------|
| 687894-1 | G | 122500-1 |
| 687894-2 | G | 565435-5 |
| 687894-3 | G | 354500-1 |

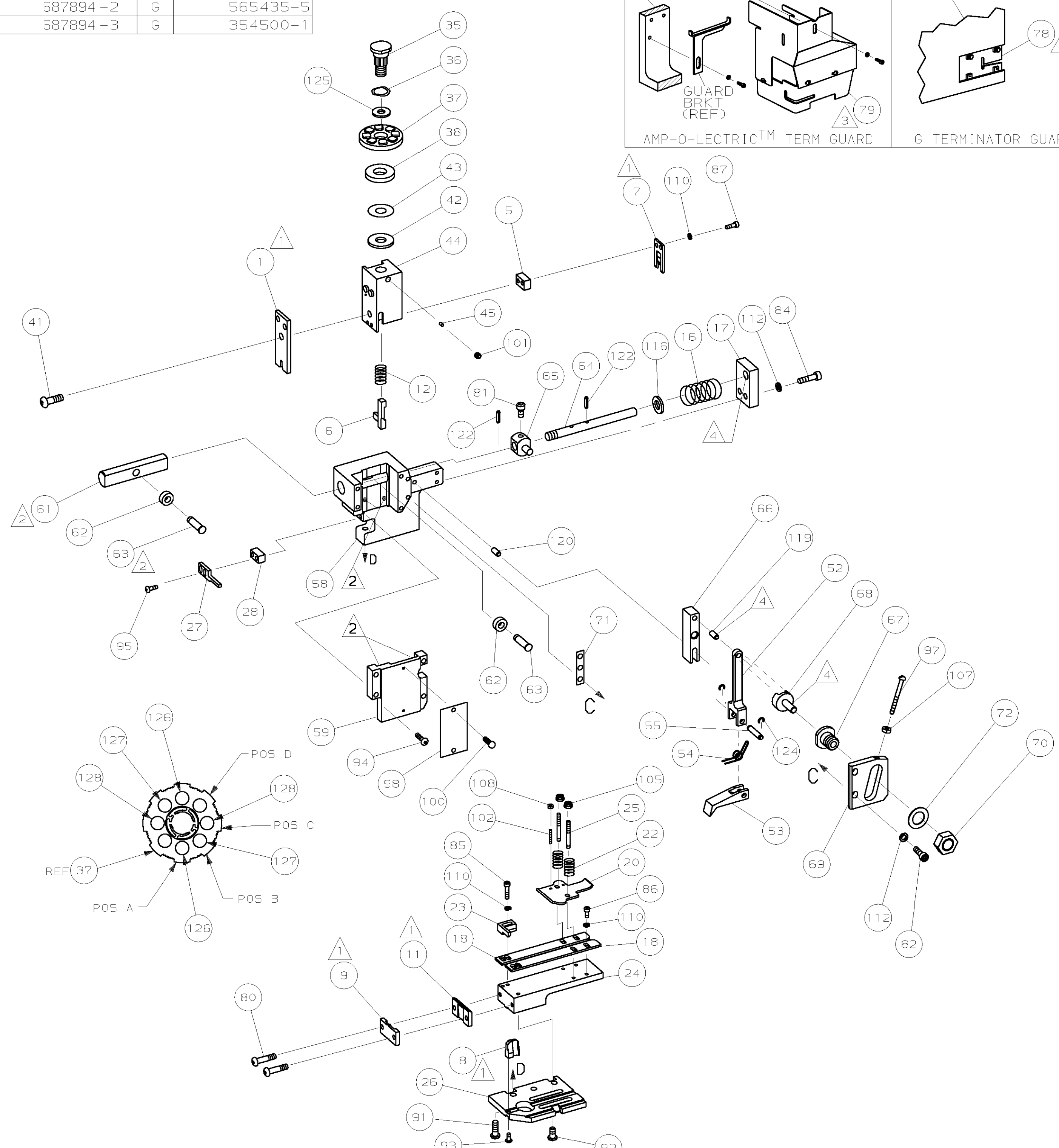
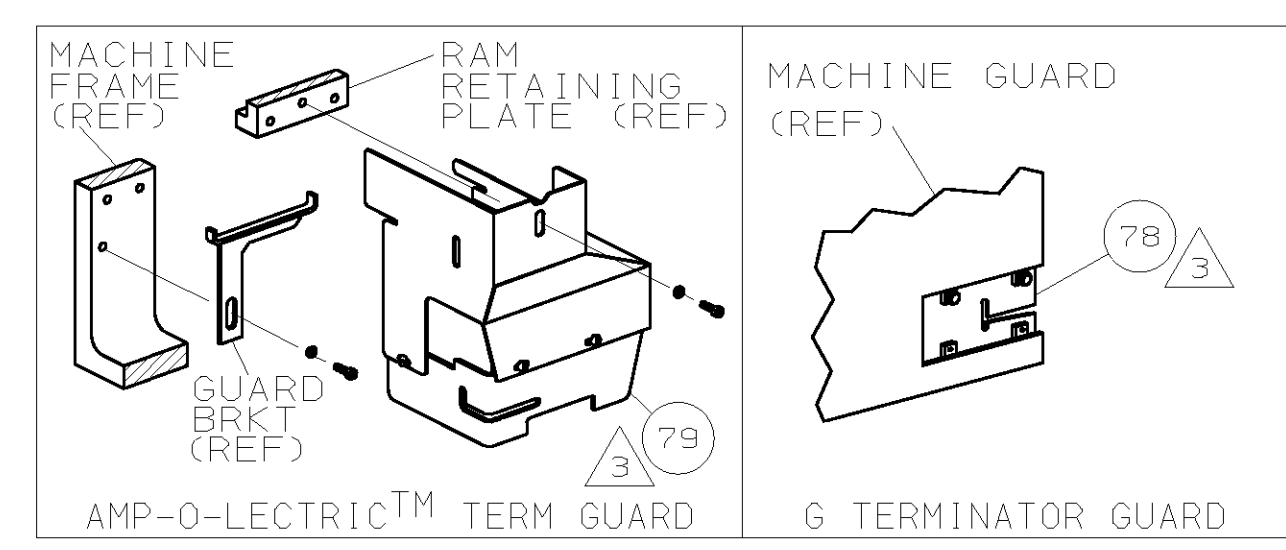

| TERMINAL NAME: PIN RECEPTACLE | | | | | |
|-------------------------------|----------------|----------------|------------------|-------------|-----------|
| 60440 | | | | | |
| PAD LTR | | | CRIMP HEIGHT | | WIRE SIZE |
| A | .045 ±.002 | [1.14 ±0.05mm] | | | 18 |
| B | .039 ±.002 | [0.99 ±0.05mm] | | | 20 |
| C | .036 ±.002 | [0.91 ±0.05mm] | | | 22 |
| D | NOT | | | | USED |
| CRIMP | SIZE | TYPE | RANGE | | |
| WIRE | .070 | [1.78mm] | F | 22-18 | |
| INSUL | | | - | | |
| WIRE STRIP LENGTH | TERM APPL SPEC | FEED | APPL INSTRUCTION | SET UP GAGE | LAYOUT |
| - | 114-02080 | .581 | 408-8039 | 458638-1 | 356 |

| QTY | REF | REF | REF | REF | REF | DESCRIPTION | ITEM NO |
|-----|-----|-----|-----|-----|-----|-------------|-------------------------------------|
| 2 | 2 | 2 | - | C | | 5-354779-0 | PIN, WIRE DISC (.3240)C 129 |
| 2 | 2 | 2 | - | C | | 4-354779-4 | PIN, WIRE DISC (.3210)B 128 |
| 2 | 2 | 2 | - | C | | 3-354779-2 | PIN, WIRE DISC (.3150)A 127 |
| 1 | 1 | 1 | - | A | | 986950-1 | WASHER, FLAT PRECISION 125 |
| REF | REF | REF | - | A | | 21045-3 | RING, RET "C" (Ø.187)FD PIN 124 |
| REF | REF | REF | - | A | | 5-21028-1 | PIN, STD SPRING(Ø.12)FD ADJ ROD 123 |
| REF | REF | REF | - | A | | 1-21030-7 | PIN, DOWEL (Ø.187x1.50)H56 122 |
| REF | REF | REF | - | A | | 1-21030-1 | PIN, DOWEL (Ø.187x.50)LEVER 121 |
| REF | REF | REF | - | A | | 21899-4 | WASHER, FLAT (Ø5/16) SCR ADJ 118 |
| REF | REF | REF | - | A | | 1-21030-7 | PIN, DOWEL (Ø.187x1.50)H56 117 |
| REF | REF | REF | - | A | | 1-21030-1 | PIN, DOWEL (Ø.187x.50)LEVER 116 |
| REF | REF | REF | - | A | | 21024-5 | WASHER, LOCK (NO.10)FD ROD GDE 115 |
| REF | REF | REF | - | A | | 21024-4 | WASHER, LOCK (NO.8)SHEAR BL 114 |
| REF | REF | REF | - | A | | 21018-4 | NUT, HEX (4-40)DRAG 113 |
| REF | REF | REF | - | A | | 21018-5 | NUT, HEX (6-32)FD ADJ PL 112 |
| REF | REF | REF | - | A | | 21022-2 | NUT, HEX SL (8-32)DRAG STUD 111 |
| REF | REF | REF | - | A | | 2-21006-6 | SCR, SKT SET (4-40x.62)DRAG 110 |
| REF | REF | REF | - | A | | 21009-2 | SCR, SKT SET (1/4-20x.25)RAM 109 |
| REF | REF | REF | - | A | | 21017-2 | SCR, DRIVE (#2x.19) ID PLATE 108 |
| REF | REF | REF | - | A | | 1-21002-7 | SCR, BHC (6-32x.38)CAM 107 |
| REF | REF | REF | - | B | | 461264-1 | PLATE, IDENTIFICATION 106 |
| REF | REF | REF | - | A | | 6-23715-5 | SCR, PAN HD (6-32x1.50)FEED ADJ 105 |
| REF | REF | REF | - | A | | 2-21002-2 | SCR, BHC (8-32x.50)STRIPPER 104 |
| REF | REF | REF | - | A | | 2-21002-9 | SCR, BHC (10-32x.75)H56 CAP 103 |
| REF | REF | REF | - | A | | 22733-8 | SCR, BHC (8-32x.38 LW)ANVIL 102 |
| REF | REF | REF | - | A | | 3-21002-3 | SCR, BHC (1/4-20x.50)ST 6D PL 101 |
| REF | REF | REF | - | A | | 2-22733-8 | SCR, BHC (1/4-20x.62)BASE PL 100 |
| REF | REF | REF | - | A | | 3-21000-6 | SCR, 5HC (10-32x.62)FEED ADJ PL 99 |
| REF | REF | REF | - | A | | 3-21000-4 | SCR, 5HC (10-32x.38)PIVOT BLOCK 98 |
| REF | REF | REF | - | A | | 3-21002-0 | SCR, BHC (10-32x.88)SHEAR PL 97 |
| REF | REF | REF | - | A | | 455745-1 | GUARD, WINDOW 96 |
| REF | REF | REF | - | A | | 679532-1 | INSERT, GUARD 95 |
| REF | REF | REF | - | A | | 458109-1 | WASHER, FLAT (SPECIAL) 94 |
| REF | REF | REF | - | A | | 690517-1 | SPACER 93 |

| -1 LEADMAKER | | MECH POST FEED | | | | | |
|------------------|-----|----------------|---|---|------------|------------------------------|----|
| -2 BENCH MODEL K | | MECH PRE FEED | | | | | |
| -3 BENCH MODEL G | | MECH PRE FEED | | | | | |
| REF | REF | REF | - | A | 22594-8 | NUT, HEX | 70 |
| REF | REF | REF | - | B | 240628-1 | PLATE, ADJ | 69 |
| REF | REF | REF | - | B | 240626-1 | SHAFT, PIVOT | 68 |
| REF | REF | REF | - | B | 240633-1 | BUSHING | 67 |
| REF | REF | REF | - | A | 455680-1 | LEVER, INTERMEDIATE | 66 |
| REF | REF | REF | - | B | 240629-1 | BLOCK, PIVOT | 65 |
| REF | REF | REF | - | A | 240632-2 | SCR, ADJ | 64 |
| REF | REF | REF | - | B | 240659-3 | PIN, CAM ROLLER | 63 |
| REF | REF | REF | - | B | 240658-1 | CAM, ROLLER | 62 |
| REF | REF | REF | - | B | 454398-1 | ROD, FEED | 61 |
| REF | REF | REF | - | C | 454220-1 | CAP, RAM | 60 |
| REF | REF | REF | - | D | 453736-1 | HOUSING | 59 |
| REF | REF | REF | - | B | 240624-1 | PIN, FEED FINGER | 58 |
| REF | REF | REF | - | B | 691499-1 | SPRING, FEED FINGER | 57 |
| REF | REF | REF | - | B | 240635-1 | FINGER, FEED | 56 |
| REF | REF | REF | - | B | 240634-1 | LEVER, TERMINAL | 55 |
| REF | REF | REF | - | B | 690602-6 | CAM, PRE-FEED 1 5/8 ST | 54 |
| REF | REF | REF | - | B | 690602-5 | CAM, PRE-FEED 1 1/8 ST | 53 |
| REF | REF | REF | - | B | 690501-4 | CAM, POST-FEED 1 5/8 ST | 52 |
| REF | REF | REF | - | A | 690191-1 | PLUG, NYLON | 51 |
| REF | REF | REF | - | C | 455674-1 | RAM | 50 |
| REF | REF | REF | - | A | 690125-1 | WASHER, LAMINATED | 49 |
| REF | REF | REF | - | A | 690124-1 | WASHER, RAM | 48 |
| REF | REF | REF | - | A | 7-21002-9 | BOLT, CRIMPER (5/16-24x1.00) | 47 |
| REF | REF | REF | - | A | 690223-2 | SPACER, INSULATION DISC | 46 |
| REF | REF | REF | - | D | 354777-1 | WIRE DISC, PLASTIC | 45 |
| REF | REF | REF | - | A | 22480-5 | WASHER, SPRING | 44 |
| REF | REF | REF | - | B | 690212-1 | POST, RAM | 43 |
| REF | REF | REF | - | A | 458980-1 | APPLICATOR, BASIC (SUB ASSY) | 42 |
| REF | REF | REF | - | A | 3-690451-2 | SPACER, STRIPPER | 41 |
| REF | REF | REF | - | A | 455566-1 | STRIPPER | 40 |
| REF | REF | REF | - | C | 455676-1 | PLATE, BASE | 39 |
| REF | REF | REF | - | A | 22354-8 | DRAG, STUD | 38 |
| REF | REF | REF | - | B | 455678-1 | PLATE, STRIP GUIDE | 37 |
| REF | REF | REF | - | C | 240825-9 | PLATE, STRIP HOLD DOWN | 36 |
| REF | REF | REF | - | A | 4-22281-1 | SPRING, DRAG | 35 |
| REF | REF | REF | - | A | 454177-1 | DRAG, STOCK | 34 |
| REF | REF | REF | - | C | 454204-1 | GUIDE, STRIP (FRONT) | 33 |
| REF | REF | REF | - | A | 454178-1 | GUIDE, FEED ROD | 32 |
| REF | REF | REF | - | A | 4-22284-9 | SPRING, FEED RETURN | 31 |
| REF | REF | REF | - | A | 23846-1 | SPRING, HOLD DOWN | 30 |
| REF | REF | REF | - | B | 240644-1 | PLATE, REAR SHEAR | 29 |
| REF | REF | REF | - | B | 690482-1 | PLATE, FRONT SHEAR | 28 |
| REF | REF | REF | - | D | 3-240654-7 | ANVIL | 27 |
| REF | REF | REF | - | B | 690474-2 | BLADE, SLUG | 26 |
| REF | REF | REF | - | D | 455892-1 | HOLD DOWN, TERMINAL | 25 |
| REF | REF | REF | - | C | 1-240641-6 | SPACER, SLUG BLADE | 24 |
| REF | REF | REF | - | C | 1-456404-8 | CRIMPER, WIRE | 23 |

| POST-FEED 1 5/8 STROKE | PRE-FEED 1 1/8 STROKE | PRE-FEED 1 5/8 STROKE |
|------------------------|----------------------------|----------------------------|
| | | |
| LEADMAKER | K TERMINATOR BENCH MACHINE | G TERMINATOR BENCH MACHINE |

1 RECOMMENDED SPARE PARTS.
 2 GREASE LIGHTLY.
 3 GUARD MUST BE IN PLACE WHEN OPERATING APPLICATOR IN A BENCH MACHINE.
 4 LUBRICATE DAILY USING NO. 20 MACHINE OIL.
 5. ITEMS WITH QTY OF REF SPECIFIED (EXCEPT ITEMS 78 AND 79) ARE USED ON ITEM 32.