

SPFEIM100_G

Fiber Optic Transceiver For Fast Ethernet



Data Sheet



Description

The 8-pin Optical Transceiver is a highly integrated CMOS IC combined with a high speed photodiode and LED designed to receive and transmit up to 125Mbit/s optical data which can be 4b5b or 8b10b coded (up to 125Mbit/s). The internal peaking and clamping circuit will yield an ideal eye-opening.

Application

Optical Transceiver for Fast Ethernet over POF

Features

The Avago high speed fiber optical transceiver for Fast Ethernet is an excellent solution for converting high speed binary data to differential digital data.

- Data rate up to 100Mbit/s (125MBaud)
- Integrated EMI shielding
- Operating temperature range 0°C to 70°C
- Operating @ 3.3V Power Supply
- Bare fiber header (which supports thin and flexible Plastic Optical Fiber (POF) with 1.5mm outer jacket diameter) integrated. Fiber pull out strength >20N (Ta = 25°C)
- Green package (lead free and halogen free)
- 650nm LED with integrated driving circuit (logic to light)
- No light toggling of the LED at no signals on the input data lines

Safety Hints

Applications of new chip technologies lead to increasing optical efficiency and growing and higher levels of optical performance. We therefore recommend that the current versions of the IEC 60825-1 and EN 60825-1 standards are taken into account right from the outset, i.e. at the equipment development stage, and that suitable protection facilities are provided.

Maximum Ratings [3], at $T_A = 25^\circ\text{C}$, unless otherwise specified

Parameter	Symbol	Min	Max	Unit
Storage Temperature Range [8]	T_{STG}	-40	+85	$^\circ\text{C}$
Soldering Temperature ($t \leq 5s$) [7]	T_S	-	245	$^\circ\text{C}$
Power Dissipation (depends on maximum temperature)	P_{TOT}	-	300	mW
Power supply voltage	V_{DDmax}	-0.5	4.0	V

Recommended Operating Conditions

Parameter	Symbol	Min	Max	Unit
Supply Voltage [4]	V_{DD}	3.05	3.55	V
Operating Temperature Range [3]	T_A	0	70	$^\circ\text{C}$

Electrical Characteristics for Transmitter ($T_A = 25^\circ\text{C}$; $V_{CC} = 3.3V$)

INPUT Parameter	Symbol	Min	Max	Unit
Data differential input voltage [5]	V_{diff_IN}	200	1200	mV
Common mode voltage [5]	V_{IN_BIAS}	GND+0.9	$V_{DD} - 0.8$	V

Characteristics LED with Standard POF ($N_A = 0.5$; $T_A = 25^\circ\text{C}$; $V_{CC} = 3.3V$)

Parameter	Symbol	Min	Typ	Max	Unit
Peak wavelength	λ_{Peak}	-	650	-	nm
Spectral bandwidth	$\Delta\lambda$	-	25	-	nm
Output power coupled into plastic fiber [1]	P_{IN}	100	150	250	μW
Mean launched power [1]	P_f	-11	-	-7	dBm, avg
Current consumption	I_{CC}	-	-	40	mA
Temperature coefficient P_{IN} [2]	TC_{Pin}	-	-0.35	-	%/K
Temperature coefficient λ_{Peak}	TC_{λ}	-	0.04	-	nm/K
Data rate [6]	B_R	-	-	125	Mbps
Rise and fall time (20-80%) optical	$t_r; t_f$	-	-	3	ns
Extinction Ratio [3]	r_e	10	-	-	dB

Electrical Characteristics for the Receiver ($T_A = 25^\circ\text{C}$; $V_{CC} = 3.3V$)

Parameter	Symbol	Min	Typ.	Max	Unit
Current consumption	$I_{CC} (Rx)$	-	30	40	mA
Differential Output Voltage (LVDS)	$[V_{QH} - V_{QL}]$	0.45	0.5	0.6	V
Output Offset Voltage	$(V_{QH} + V_{QL})/2$	-	1.2	-	V
Output rise and fall time (10-90%)	$t_r; t_f$	-	-	3	ns

Optical Signal Characteristics for Receiver ($N_A = 0.5$; $T_A = 25^\circ\text{C}$; $V_{CC} = 3.3V$)

Parameter	Symbol	Min	Max	Unit
Minimum Receiver Input Power (BER < 10^{-9})	P_{RxMin}	-22	-	dBm
Overload (BER < 10^{-9})	P_{RxMax}	-	-4	dBm

Link Characteristics ($T_A = 25^\circ\text{C}$; $V_{CC} = 3,3\text{V}$)

Parameter	Symbol	Value
Transmission length (Fiber: $N_A 0.5$; attenuation 0.2dB/m)	L_{POF}	up to 50m ^[9]

Notes:

1. The output power coupled into plastic fiber P_{IN} is measured with a large area detector at the end of a short length of fiber (about 2m). The 2m long POF is being used in order not to measure the power in the leaky modes (optical power not guided in a long fiber).
2. The temperature coefficient P_{IN} is described between $+20^\circ\text{C}$ and 70°C by using a linear coefficient
3. Defined by design (reviewed by monitoring, qualification and/ or characterisation). Not subject to production test
4. For Receiver defined by design (reviewed by monitoring, qualification and/ or characterisation). Not subject to production test
5. Tested with one fixed parameter
6. Max. testing data rate = 100Mbps; 125Mbps are defined by design (reviewed by characterisation and qualification)
7. In case of rework max. 1 time repair soldering is permitted (for more details see Application information).
8. Moisture sensitivity classification is MSL4 according to JEDEC J-STD-020C (for more details see Application information).
9. System test on reference board with INFINEON NINJA switch IC using clock recovery, random pattern and 100 Mbps net data rate.

Package outline

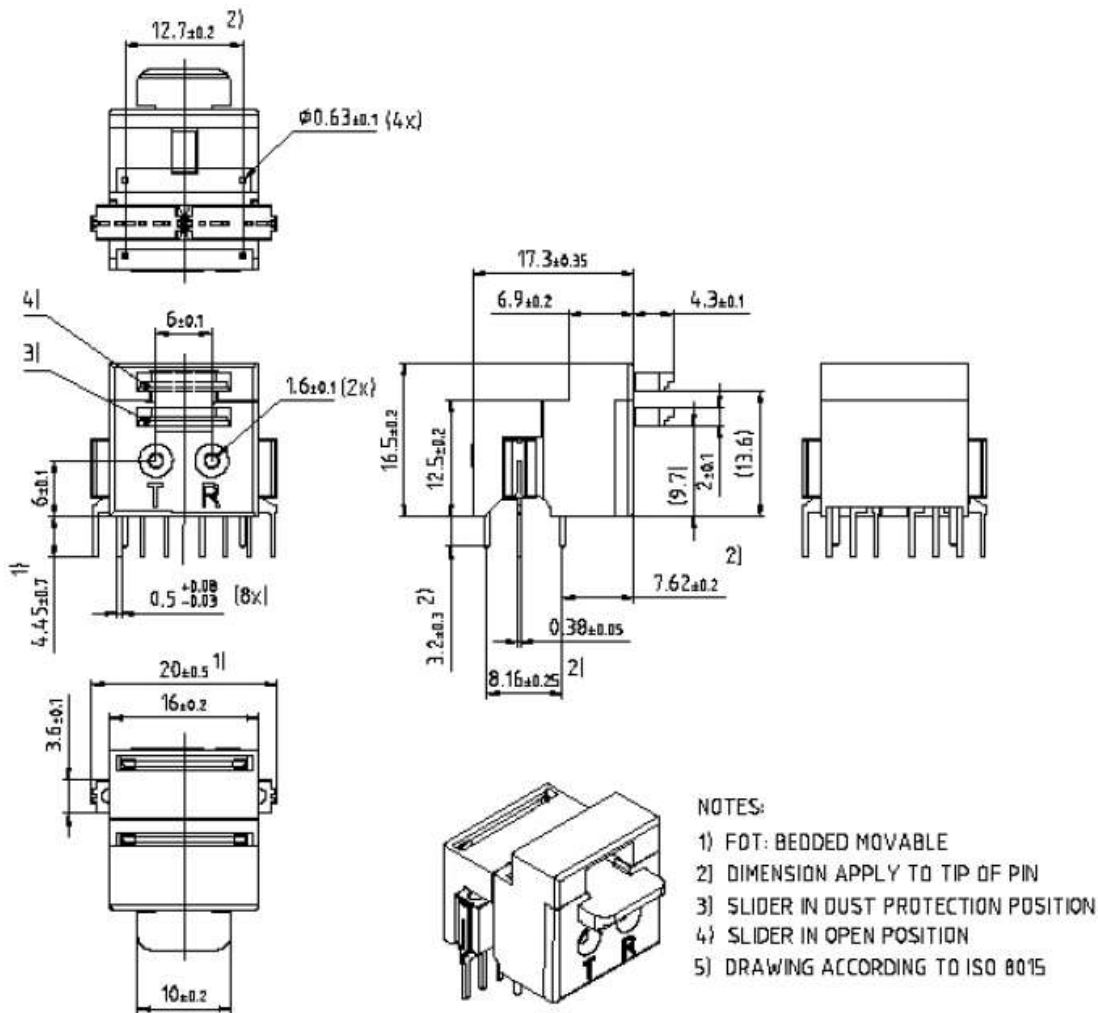

Footprint of Device (unit: mm)

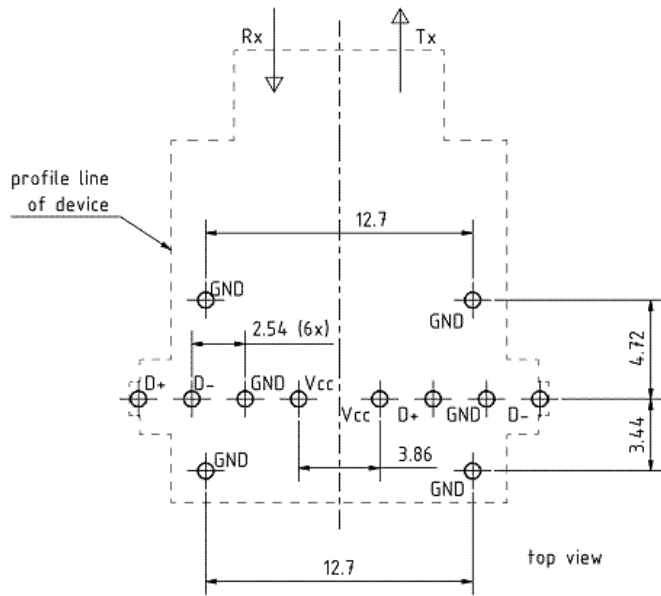

Recommended application

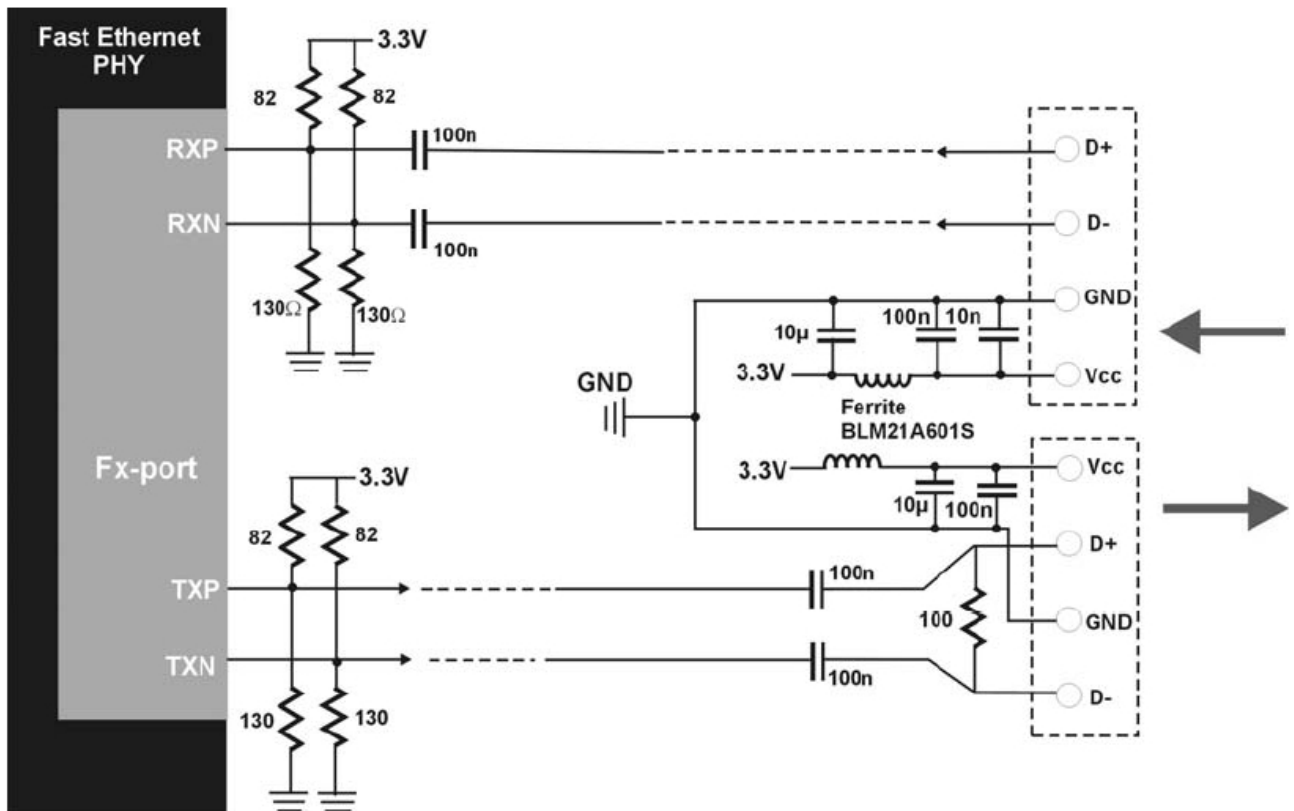

Note:

Shown is the minimum external circuitry at DC-coupling for the connection of the optical receiver to a FE-PHY. DC-coupling would be possible, if the common mode voltage and voltage swing at the data lines are within the recommended values (see electrical characteristics, parameters). Please use the product information of the actual Fast Ethernet PHY for connecting to the optical transmitter

Disclaimer

The information herein is given to describe certain components and shall not be considered as a guarantee of characteristics.

Terms of delivery and rights to technical change reserved. We hereby disclaim any and all warranties, including but not limited to warranties of non-infringement, regarding circuits, descriptions and charts stated herein.

Warnings

Due to technical requirements components may contain dangerous substances. For information on the types in question please contact your nearest Avago Technologies Office.

Avago Technologies Components may only be used in life-support devices or systems with the express written approval of Avago Technologies, if a failure of such components can reasonably be expected to cause the failure of that life-support device or system, or to affect the safety or effectiveness of that device or system. Life support devices or systems are intended to be implanted in the human body, or to support and/or maintain and sustain and/or protect human life. If they fail, it is reasonable to assume that the health of the user or other persons maybe endangered.

Information

For further information on technology, delivery terms and conditions and prices please contact your nearest Avago Technologies Office (www.avagotech.com).

For product information and a complete list of distributors, please go to our web site: www.avagotech.com

Avago, Avago Technologies, and the A logo are trademarks of Avago Technologies, Limited in the United States and other countries.
Data subject to change. Copyright © 2007 Avago Technologies Limited. All rights reserved.
AV01-0741EN - July 1, 2007

Avago
TECHNOLOGIES