

REVISIONS					
REV.	DATE	DESCRIPTION	DATE	BY	APPV.
G3	27AUG02	DRAWING OVERWORKED		MP	MB
G4	29.03.06	SILVER VARIANT ADDED		KF	MP
H	26OCT2016	ECR-16-009856		VH	JP
H1	15SEP2017	NOTE 9 IS ADDED, SPEC NUMBERS ARE UPDATED		GH	RM

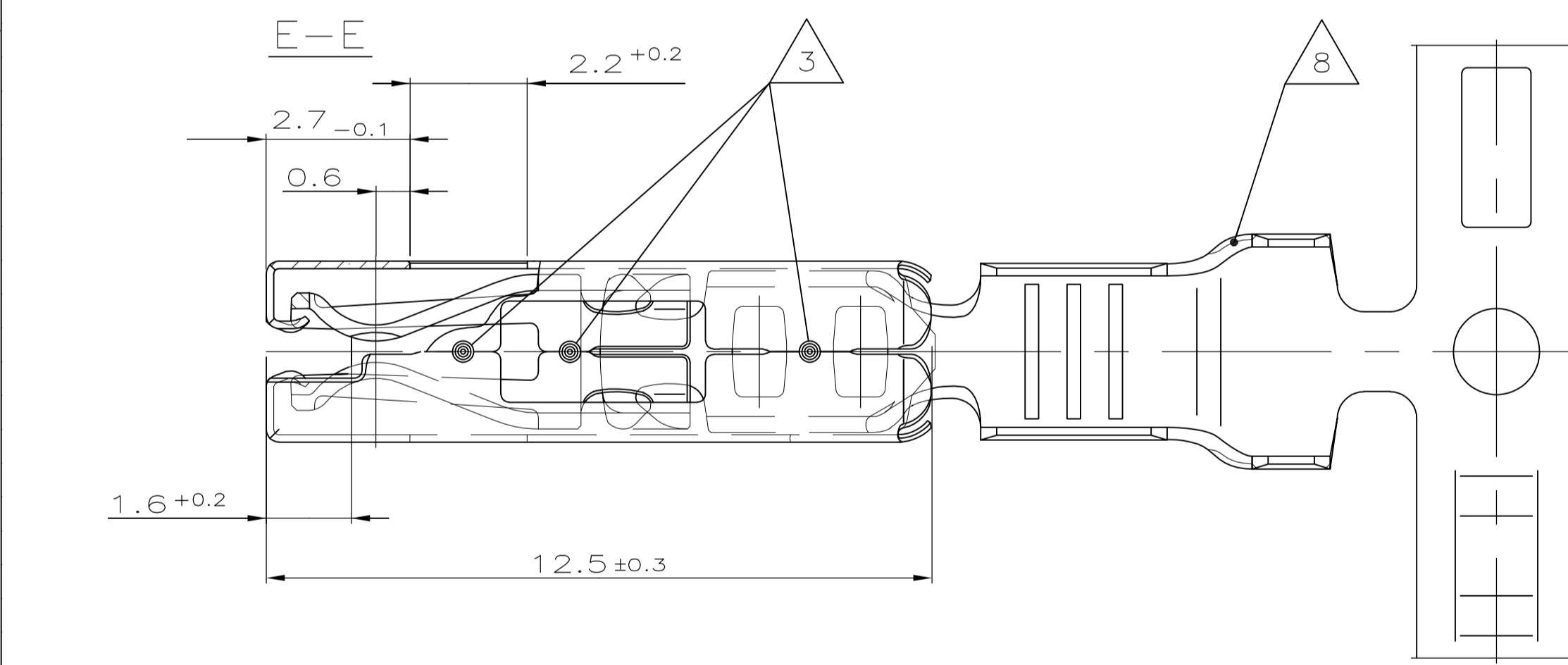

- |  |  |
|--|--|
| 1. TO BE USED ON TAB 1.5±0.1x0.8+0.04/-0.03                                  | 1. Geeignet fuer Flachstecker 1.5±0.1x0.8+0.04/-0.03   |
| 2 MAXIMUM INSERTION DEPTH  | 2 Groesste Einstecktiefe   |
| 3 LASERWELDED (4x)   | 3 Lasergeschweisst (4x)  |
| 4 BRANDNAME AND REVISION STATUS  | 4 Hersteller-Logo und Revisionsstand   |
| 5 1µm TO 1.4µm GOLDPLATE OVER NICKEL IN LOCALIZED AREA; TINPLATED REMAINDER. | 5 1µm bis 1.4µm Goldueberzug ueber Nickel im gekennzeichneten Bereich; Rest galvanisch verzinkt. |
| 6 INDEX AT SPRING FOR GOLDPLATING ONLY                                       | 6 Kennzeichnung an der Ueberfeder fuer Vergoldung  |
| 7 3-5µm SILVERPLATING IN LOCALIZED AREA TINPLATED REMAINDER                  | 7 3-5µm Silberueberzug im gekennzeichneten Bereich Rest galvanisch verzinkt                      |
| 8 BREAK EDGE IN THIS AREA  | 8 Kante in diesem Bereich entschaefft  |
| H1 9 INDEX 'Au' FOR GOLD PLATING, 'Ag' FOR SILVERPLATING                     | 9 Kennzeichnung 'Au' nur fuer Goldueberzug, 'Ag' fuer Silberueberzug                             |

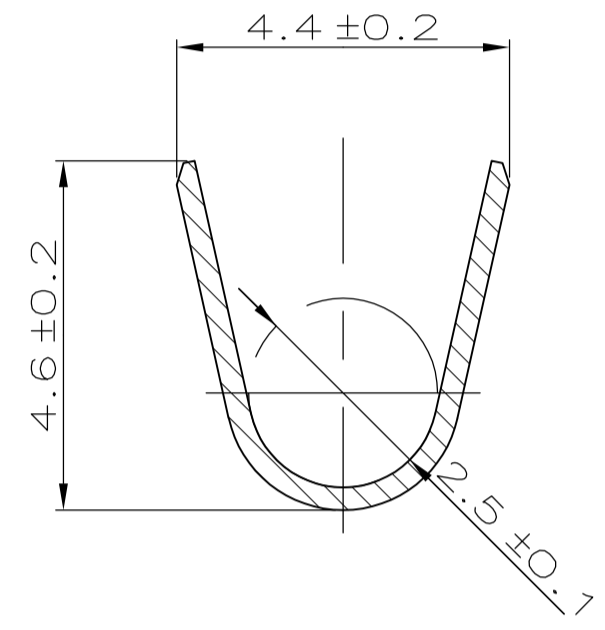
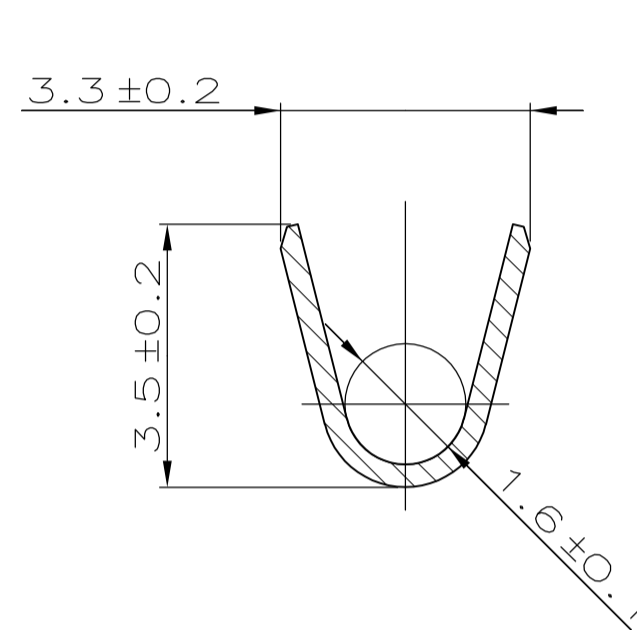
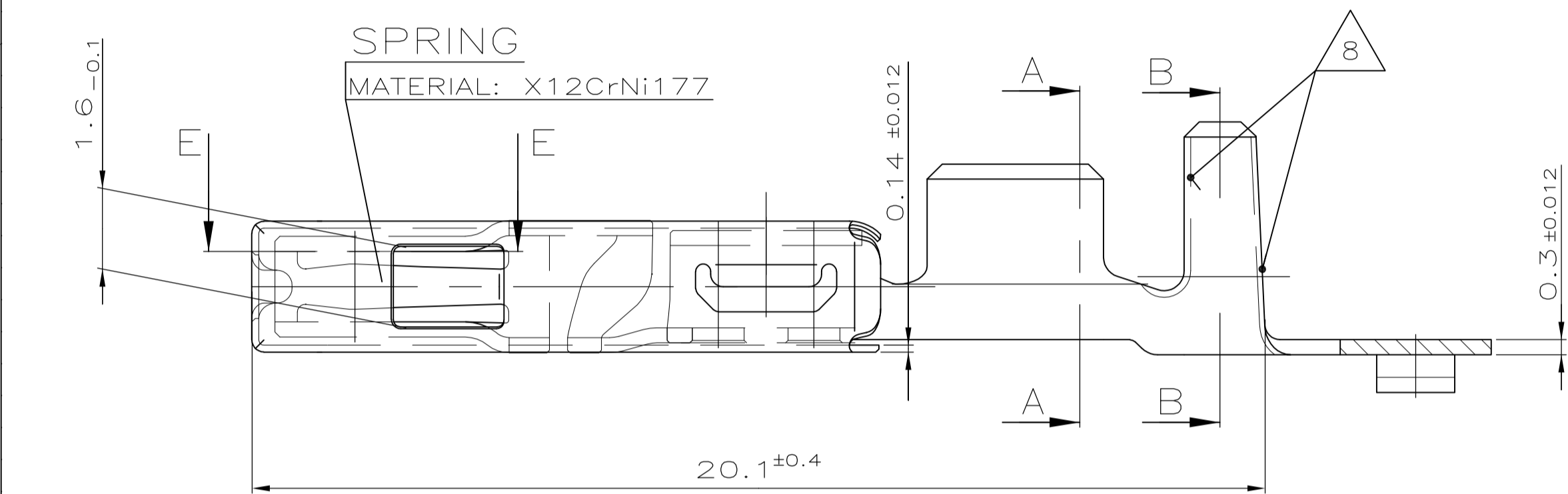
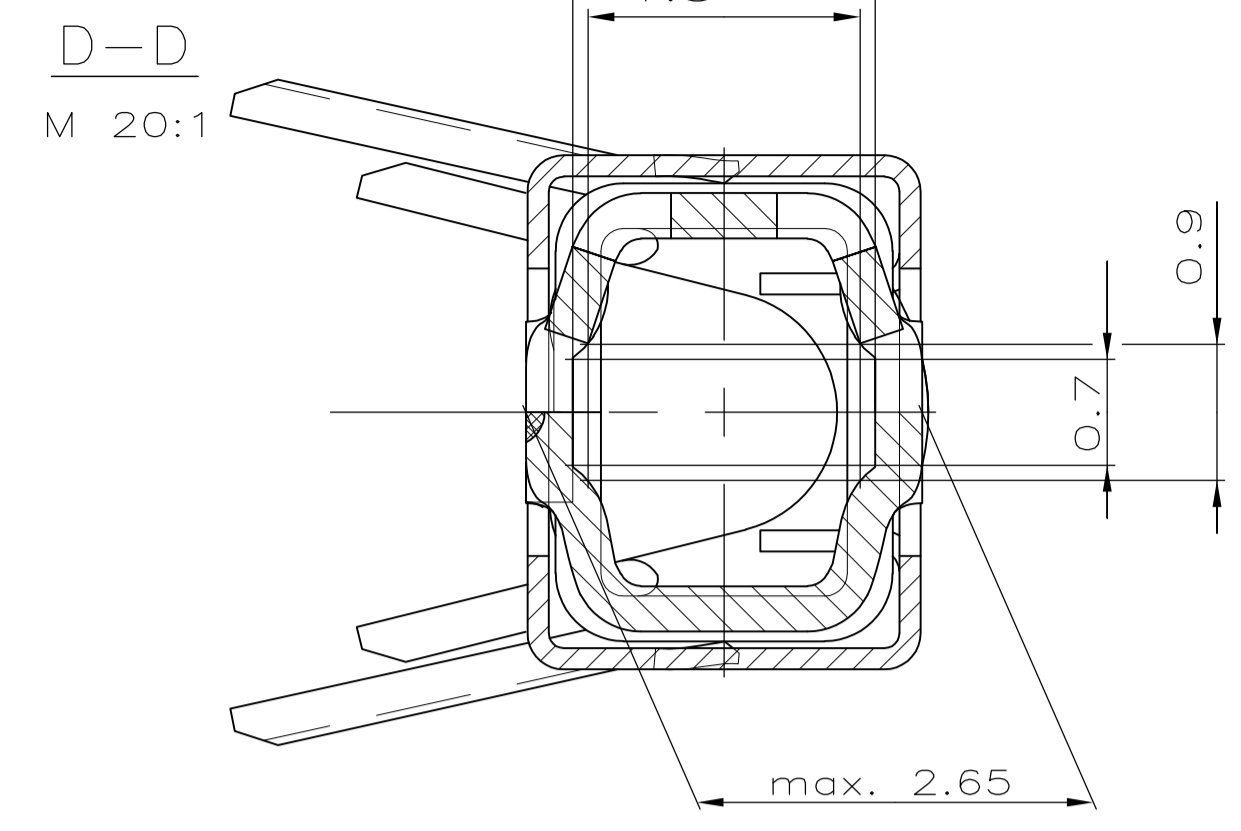
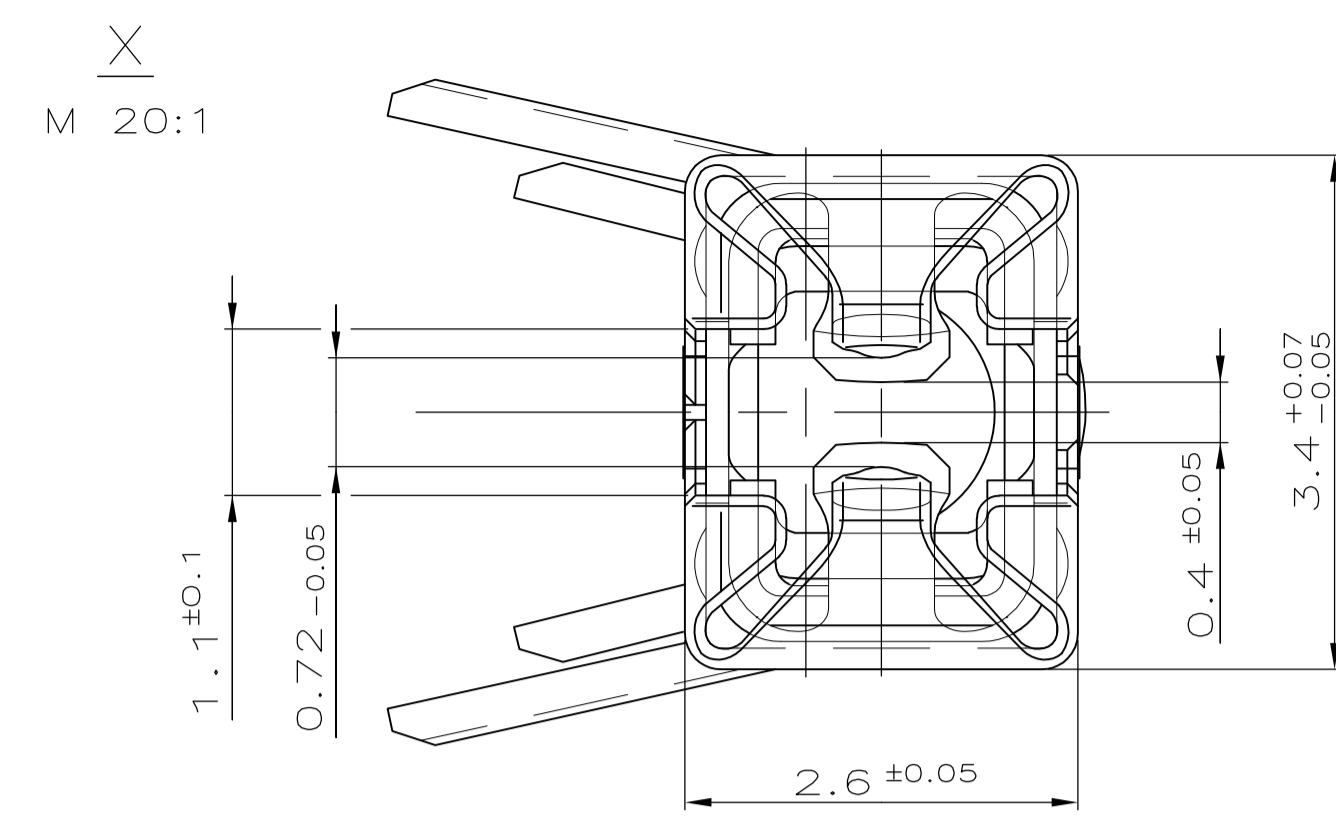
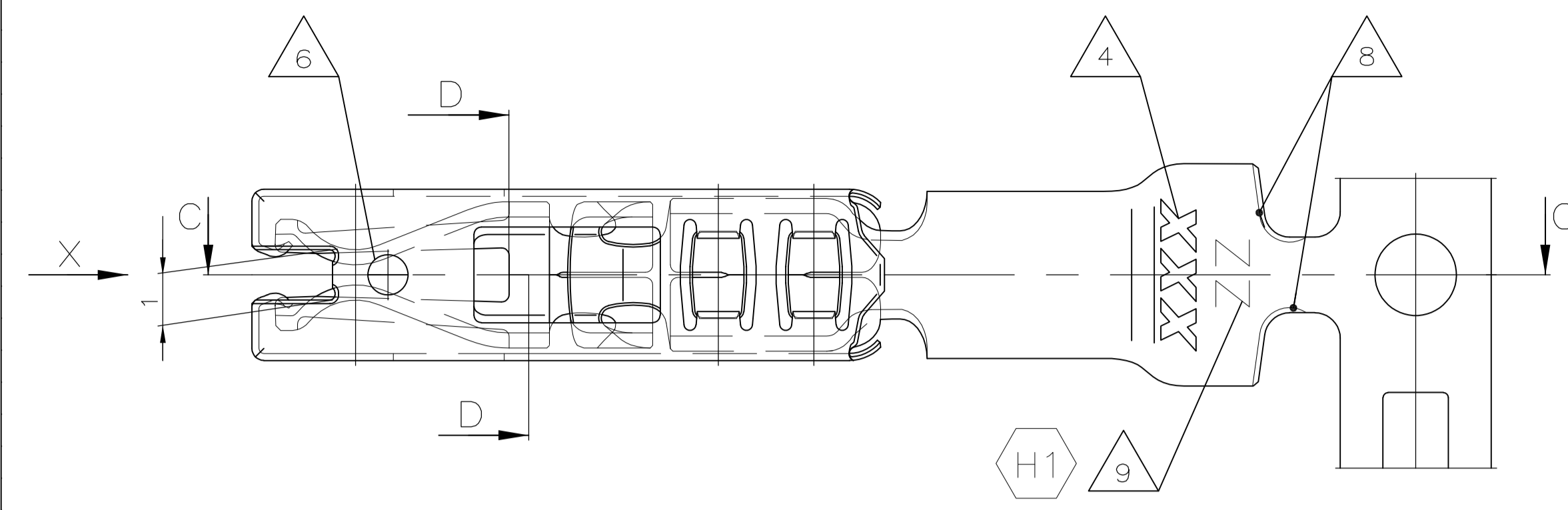
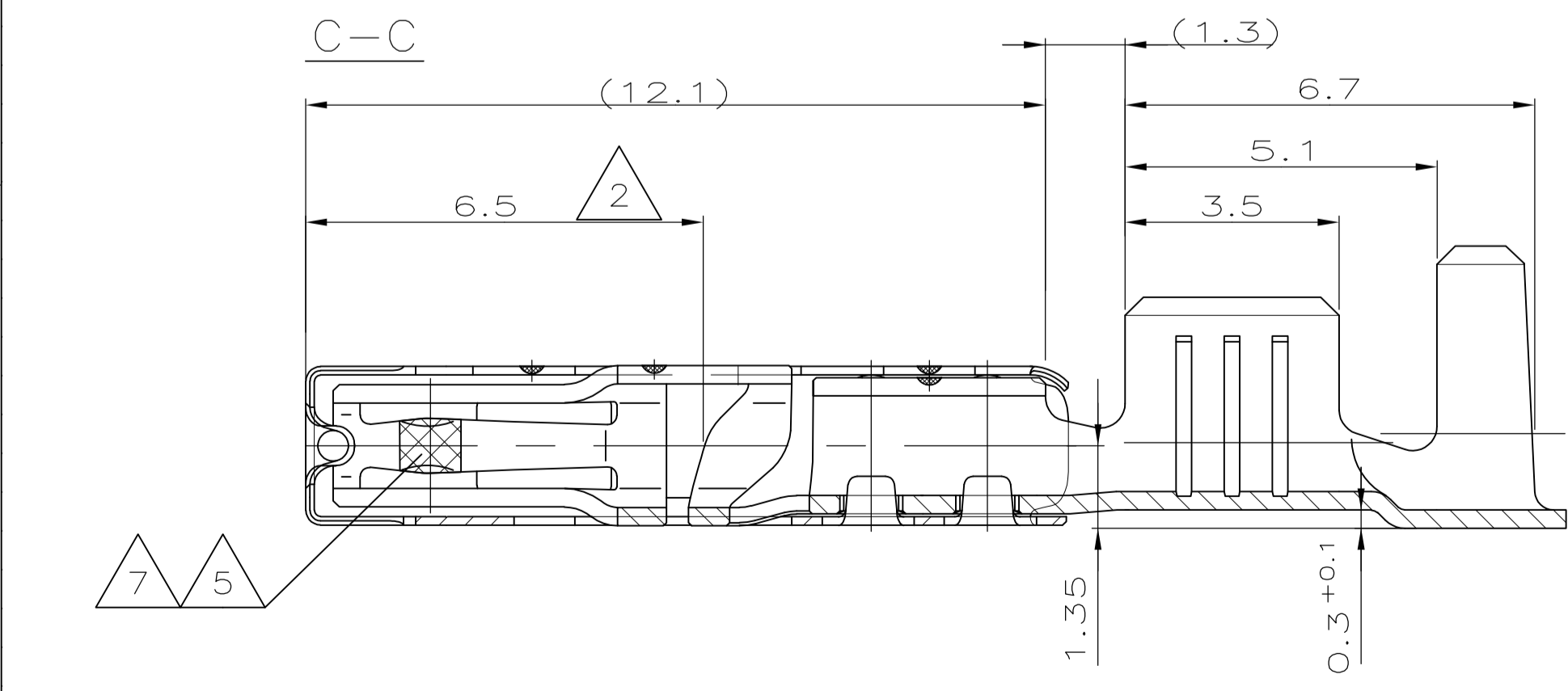

DIE IDENTIFICATION	TYPE OF PRODUCT	DWG.-NO.
4	SERIE	929025
3		

REV.	CUSTOMER PART NO	AMP PART NO	REV.	PCS.	MATERIAL	SURFACE COLOR	DESCRIPTION
-	-	-	-	-	-	-	-
A	-	929025-3	A	-	CuNiSi	SILVER/TINPLATED	WIRE SIZE 1,4 TO 2mm <sup>2</sup>
C	-	929025-2	C	-	CuNiSi	PRETINNED	WIRE SIZE 1,4 TO 2mm <sup>2</sup>
G	-	929025-1	G	△	CuNiSi	GOLD-/TINPLATED	WIRE SIZE 1,4 TO 2mm <sup>2</sup>

THIS DRAWING IS A CONTROLLED DOCUMENT.

DMB Egenolf, B. 10-NOV-1997  
 CHK Egenolf, B. 03-JUL-2001  
 APVD Bleicher, M. 15-NOV-2001

NAME: 1,5mm SENSOR FLATTYPE RECEPTACLE  
 1,5mm Sensor Flachkontakt

PRODUCT SPEC: 108-18617  
 APPLICATION SPEC: 114-18254-1

SIZE: A1  
 CASE CODE: 00779  
 DRAWING NO: 929025  
 WEIGHT: -

CUSTOMER DRAWING SCALE: 10:1 SHEET: 1 of 1 REV: H1