MTCH6102 Low-Power Projected Capacitive Touch Controller

Description:

Microchip's MTCH6102 is a turnkey projected capacitive touch controller that simplifies adding gestures to touch interface designs with industry-leading low-power performance. It utilizes up to 15 channels to support taps, swipes, and scrolling on XY touch pads and touch screens. MTCH6102 allows designers to quickly and easily integrate projected capacitive touch into their cost-sensitive, low-power application. MTCH6102 provides developers with a flexible touch-sensing solution to optimize common constraints of size, power and cost that are critical to applications such as wearable devices, remote controls, gaming devices and track pads.

Applications:

- Wearable Devices such as Headphones, Watches, Fitness Wristbands
- Track Pads and Computer Peripherals
- Input Devices with Configurable Button, Keypad or Scrolling Functions
- Any Interface with Single-Finger Gestures to Swipe, Scroll, or Doubletap Controls
- Home Automation Control Panels
- Security Control Keypads
- Automotive Center Stack Controls
- Gaming Devices
- Remote Control Touch Pads

Touch Sensor Support:

- Up to 15 Channels
- Sensor Sizes up to 120 mm (4.7")
- Individual Channel Tuning for Optimal Sensitivity
- Works with Printed Circuit Board (PCB) Sensors, Film, Glass and Flexible Printed Circuit (FPC) Sensors

Cover Layer Support:

- Plastic: up to 3 mm
- Glass: up to 5 mm

Touch Performance:

- >200 Reports per Second (configurable)
- 12-Bit Resolution Coordinate Reporting

Touch Features:

- Gesture Detection and Reporting
- Self-Capacitance Signal Acquisition
- Multiple Built-in Filtering Options

Power Management:

- Configurable Sleep/Idle Frame Rates
- Standby mode <500 nA (typical)
- Active mode <12 uA possible

Communication Interface:

- I²C™ (up to 400 kbps)
- Both Polling and Interrupt Schemes Supported
- Sync Signal Allows for Host Frame Detection
- Field Upgradeable over I²C

Operating Conditions:

- 1.8V to 3.6V, -40°C to +85°C

Package Types:

- 28-Pin SSOP
- 28-Pin UQFN

MTCH6102

Table of Contents

1.0	MTCH6102 Block Diagram	3
2.0	Pin Diagrams	4
3.0	MTCH6102 Pinout Description	5
4.0	Layout	6
5.0	Communication	8
6.0	Sensor Design Considerations	10
7.0	Operating Modes	13
8.0	Controller Commands	15
9.0	Touch Frame Control	16
10.0	Touch Data Registers	17
11.0	Acquisition and Touch Parameters	18
12.0	Compensation RAM	20
13.0	Baseline	21
14.0	Gesture Features and Parameters	22
15.0	Configuring a Non-Default Application	26
16.0	Manufacturing Testing	27
17.0	Memory Map	28
18.0	Electrical Characteristics	31
19.0	Ordering Information	35
20.0	Packaging Information	36
	The Microchip Web Site	43
	Customer Change Notification Service	43
	Customer Support	43
	Worldwide Sales and Service	45

TO OUR VALUED CUSTOMERS

It is our intention to provide our valued customers with the best documentation possible to ensure successful use of your Microchip products. To this end, we will continue to improve our publications to better suit your needs. Our publications will be refined and enhanced as new volumes and updates are introduced.

If you have any questions or comments regarding this publication, please contact the Marketing Communications Department via E-mail at docerrors@microchip.com. We welcome your feedback.

Most Current Data Sheet

To obtain the most up-to-date version of this data sheet, please register at our Worldwide Web site at:

<http://www.microchip.com>

You can determine the version of a data sheet by examining its literature number found on the bottom outside corner of any page. The last character of the literature number is the version number, (e.g., DS30000000A is version A of document DS30000000).

Errata

An errata sheet, describing minor operational differences from the data sheet and recommended workarounds, may exist for current devices. As device/documentation issues become known to us, we will publish an errata sheet. The errata will specify the revision of silicon and revision of document to which it applies.

To determine if an errata sheet exists for a particular device, please check with one of the following:

- Microchip's Worldwide Web site; <http://www.microchip.com>
- Your local Microchip sales office (see last page)

When contacting a sales office, please specify which device, revision of silicon and data sheet (include literature number) you are using.

Customer Notification System

Register on our web site at www.microchip.com to receive the most current information on all of our products.

1.0 MTCH6102 BLOCK DIAGRAM

FIGURE 1-1: MTCH6102 BLOCK DIAGRAM

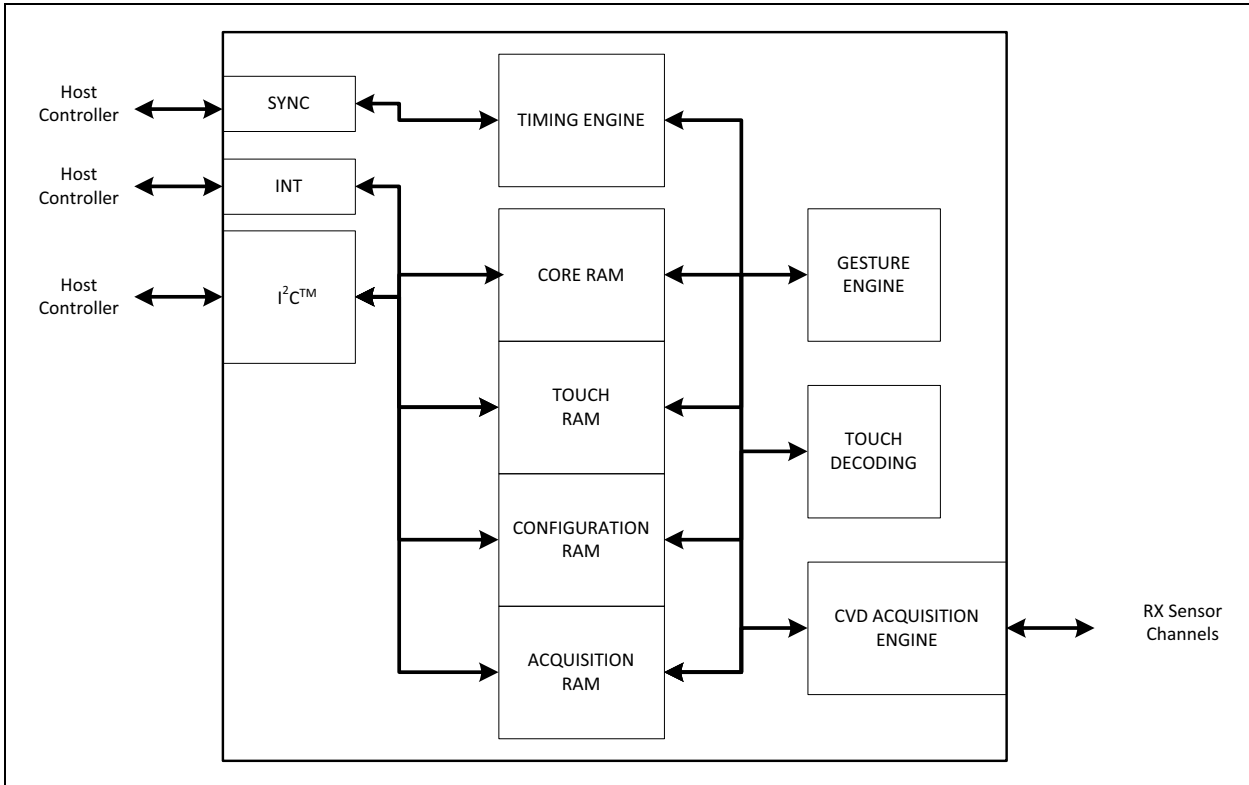

MTCH6102

2.0 PIN DIAGRAMS

FIGURE 2-1: 28-PIN UQFN (4X4)

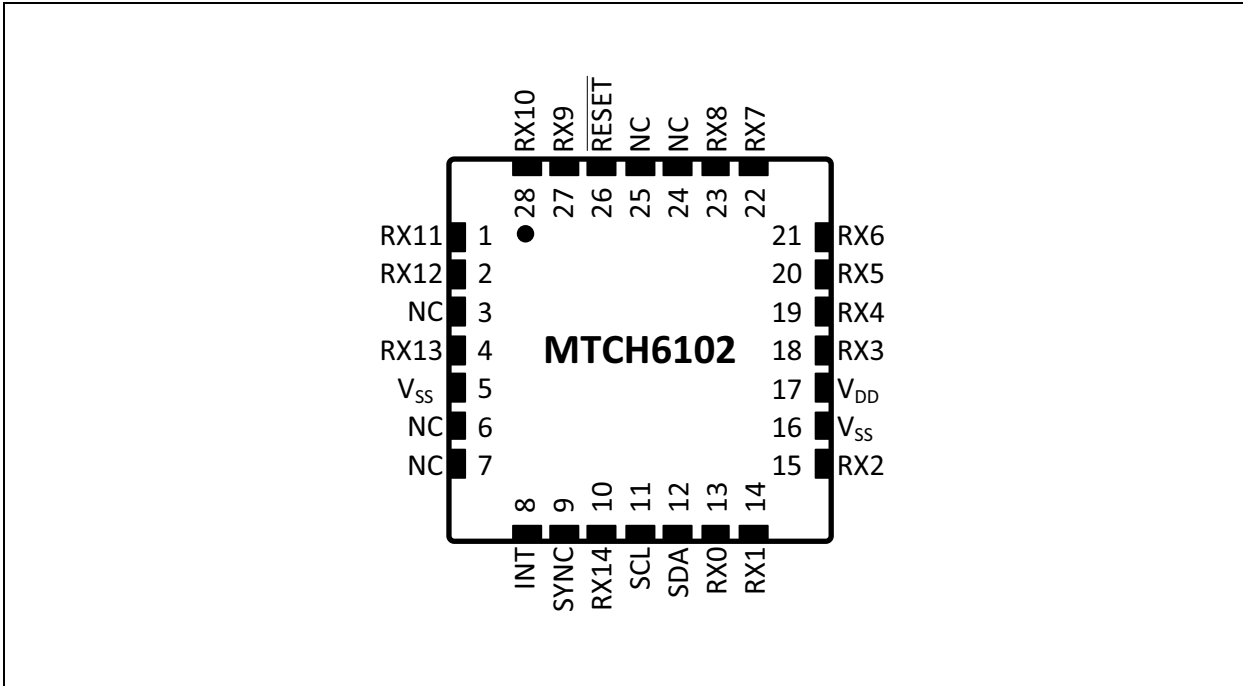
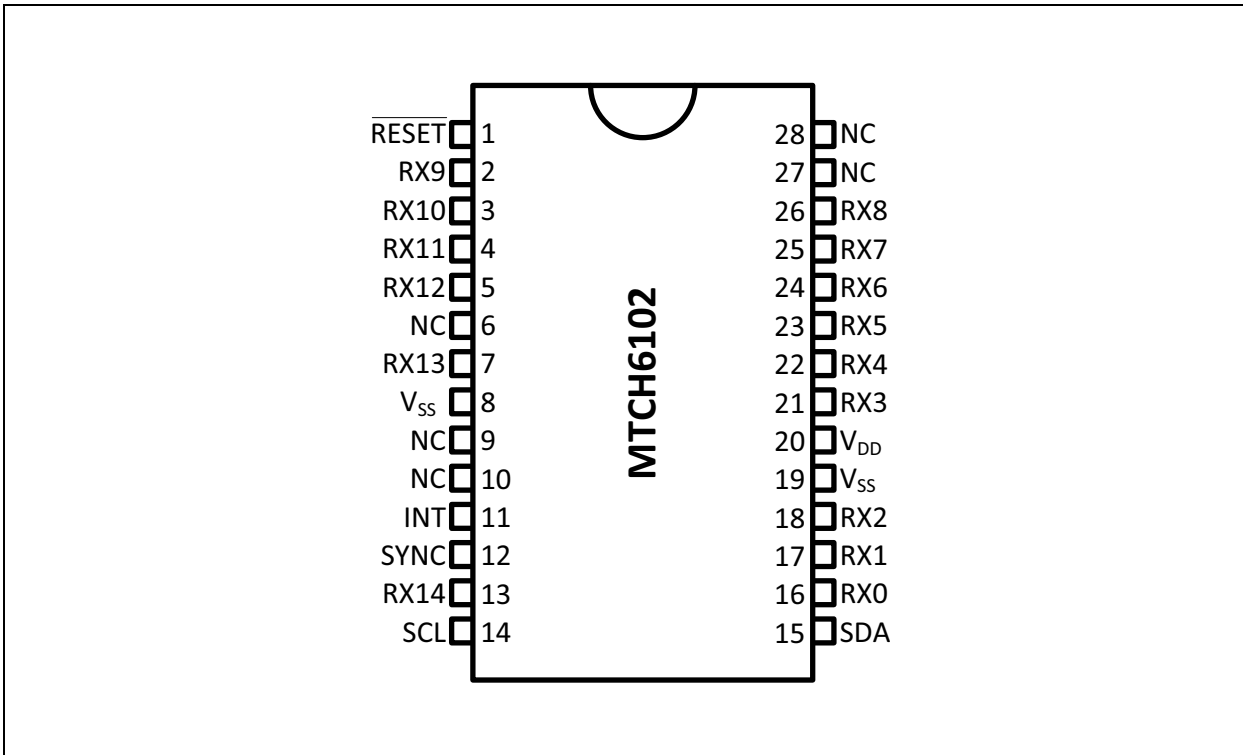

FIGURE 2-2: 28-PIN SSOP



3.0 MTCH6102 PINOUT DESCRIPTION

TABLE 3-1: MTCH6102 PINOUT DESCRIPTION

Pin Name	UQFN Pin	SSOP Pin	Pin Type	Description
RESET	26	1	I	Master Reset with Internal Pull-up
SCL	11	14	I/O	I ² C™ Clock
SDA	12	15	I/O	I ² C Data Input/Output
INT	8	11	O	Interrupt Request Output
SYNC	9	12	O	Synchronous Frame Output
RX0	13	16	I/O	Touch Sensor Channel Input
RX1	14	17	I/O	
RX2	15	18	I/O	
RX3	18	21	I/O	
RX4	19	22	I/O	
RX5	20	23	I/O	
RX6	21	24	I/O	
RX7	22	25	I/O	
RX8	23	26	I/O	
RX9	27	2	I/O	
RX10	28	3	I/O	
RX11	1	4	I/O	
RX12	2	5	I/O	
RX13	4	7	I/O	
RX14	10	13	I/O	
VDD	17	20	Power	Positive Supply
VSS	5,16	8,19	Power	Ground Reference
N/C	3, 6, 7, 24, 25	6, 9, 10, 27, 28	N/C	No Connect

MTCH6102

4.0 LAYOUT

FIGURE 4-1: TYPICAL APPLICATION CIRCUIT

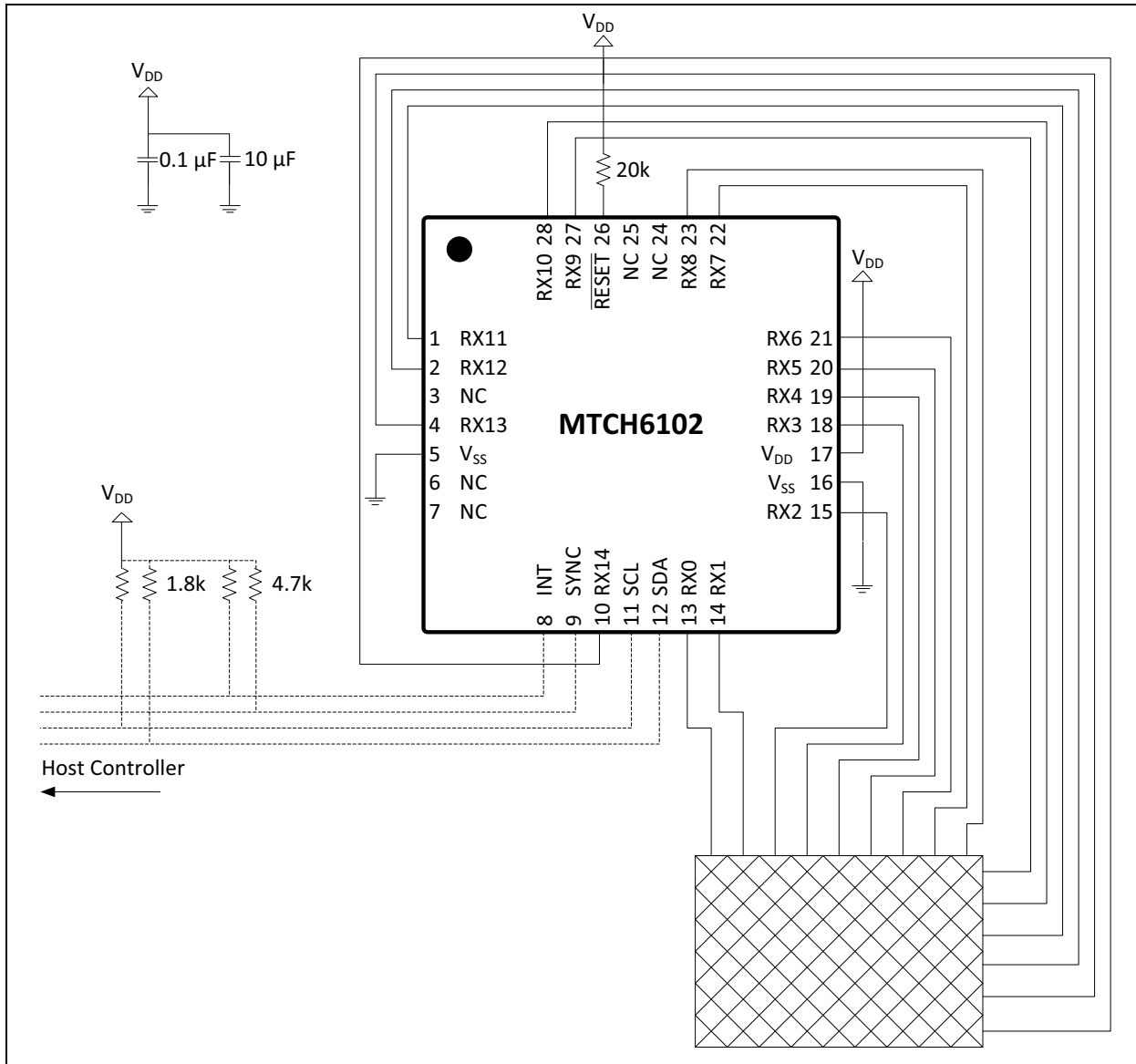

4.1 Decoupling Capacitors

The use of decoupling capacitors on power-supply pins, such as VDD and VSS, is required. Consider the following criteria when using decoupling capacitors:

1. Value and type of capacitor:

A value of 0.1 μF (100 nF), 10-20V is recommended. The capacitor should be a low Equivalent Series Resistance (low ESR) capacitor and have resonance frequency in the range of 20 MHz and higher. It is further recommended that ceramic capacitors be used.

2. Placement on the Printed Circuit Board:

The decoupling capacitors should be placed as close to the pins as possible. It is recommended that the capacitors be placed on the same side of the board as the device. If space is constricted, the capacitor can be placed on another layer on the PCB using a via; however, ensure that the trace length from the pin to the capacitor is within one-quarter inch (6 mm) in length.

3. Handling high-frequency noise:

If the board is experiencing high-frequency noise, upward of tens of MHz, add a second ceramic-type capacitor in parallel to the above-described decoupling capacitor. The value of the second capacitor can be in the range of 0.01 μF to 0.001 μF . Place this second capacitor next to the primary decoupling capacitor. In high-speed circuit designs, consider implementing a decade pair of capacitances as close to the power and ground pins as possible (for example, 0.1 μF in parallel with 0.001 μF).

4. Maximizing performance:

On the board layout from the power supply circuit, run the power and return traces to the decoupling capacitors first, and then to the device pins. This ensures that the decoupling capacitors are first in the power chain. It is equally important to keep the trace length between the capacitor and the power pins to a minimum, thereby reducing PCB track inductance.

4.2 Bulk Capacitors

The use of a bulk capacitor is recommended to improve power-supply stability. Typical values range from 4.7 μF to 47 μF . This capacitor should be located as close to the device as possible.

MTCH6102

5.0 COMMUNICATION

5.1 I²C Pin Specification

5.1.1 DESCRIPTION

The MTCH6102 low-power projected capacitive touch controller uses a standard register-based read/write I²C protocol based upon the memory map. This protocol is similar to many other devices such as temperature sensors and serial EEPROMs. Although data can be read at any time (polling), an interrupt pin (INT) is provided for flexible integration options.

5.1.2 READING/WRITING REGISTERS

To access memory (both to read or write), the I²C transaction must start by addressing the chip with the Write bit set, then writing out a single byte of data representing the memory address to be operated on. After that, the host can choose to do either of the following (see Figure 5-1):

1. To write memory, continue writing [n] data bytes (see Figure 5-2).
2. To read memory, restart the I²C transaction (via either a Stop-Start or Restart), then address the chip with the Read bit set. Continue to read in [n] data bytes (see Figure 5-3).

During either of these transactions, multiple bytes within the same block may be read or written due to the device's address auto-increment feature. See Section 17.0 "Memory Map" for block separation.

FIGURE 5-1: I²C™ TRANSACTION DIAGRAM

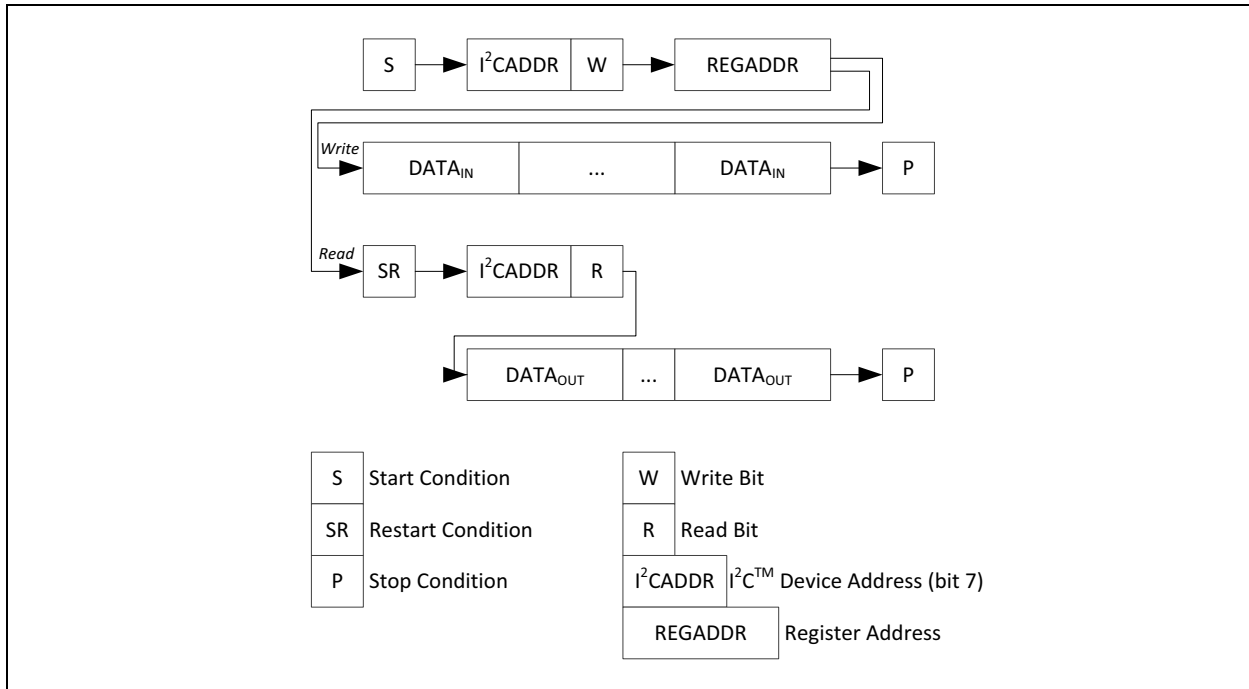

FIGURE 5-2: EXAMPLE I²C™ WRITE TRANSACTION

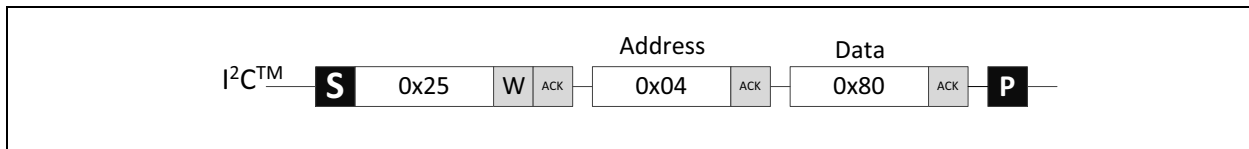
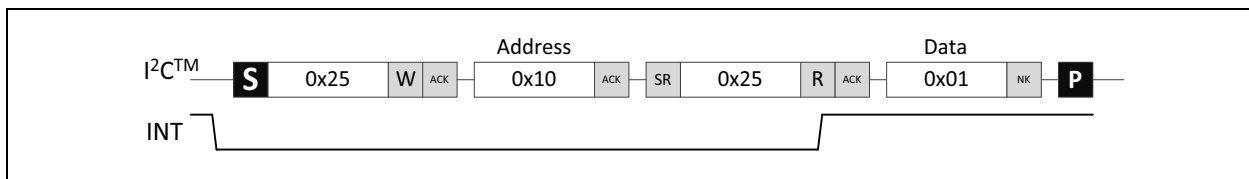

FIGURE 5-3: EXAMPLE I²C™ READ TRANSACTION



5.1.3 DEVICE ADDRESSING

The MTCH6102 default 7-bit base address is 0x25. Every transmission must be prefixed with this address, as well as a bit signifying whether the transmission is a master write ('0') or master read ('1'). After appending this Read/Write bit to the base address, this first byte becomes either 0x4A (write) or 0x4B (read).

This address can be modified (see [I²CADDR](#)), but this requires initially communicating with the device under the default address. If this is not feasible in the user's application, contact Microchip support for additional options.

5.2 Interrupt Pin

MTCH6102 provides an open-collector active-low Interrupt pin (INT) that will be asserted any time new data is available. INT is automatically released under two conditions:

1. A read is performed of *any* register within the device.
2. The next frame of decoding has started.

5.3 SYNC Output Pin

MTCH6102 provides an active-high sync signal that correlates with the current touch frame status. The SYNC pin is low while the device is sleeping (between frames) and high while touch sensing/decoding is occurring. A common use of this pin includes a host that makes use of data on every frame (such as raw-acquisition data), for host-side decoding (see [Figure 5-4](#)).

FIGURE 5-4: EXAMPLE INT/SYNC LOGIC

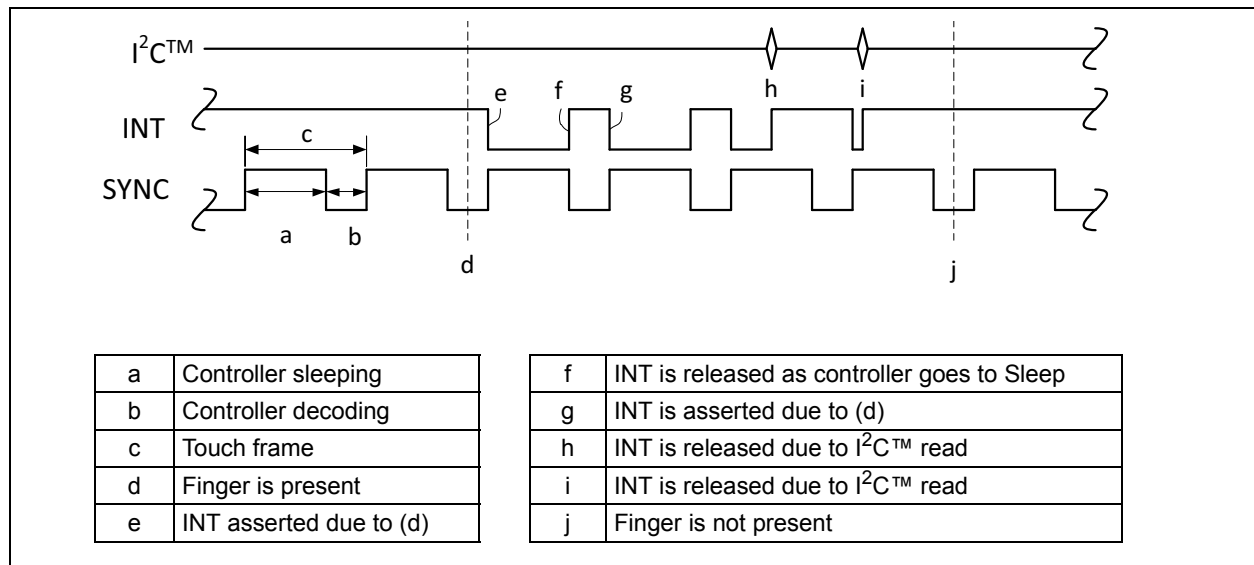

MTCH6102

6.0 SENSOR DESIGN CONSIDERATIONS

6.1 General Guidelines

FIGURE 6-1: DIAMOND DIMENSION GUIDELINES

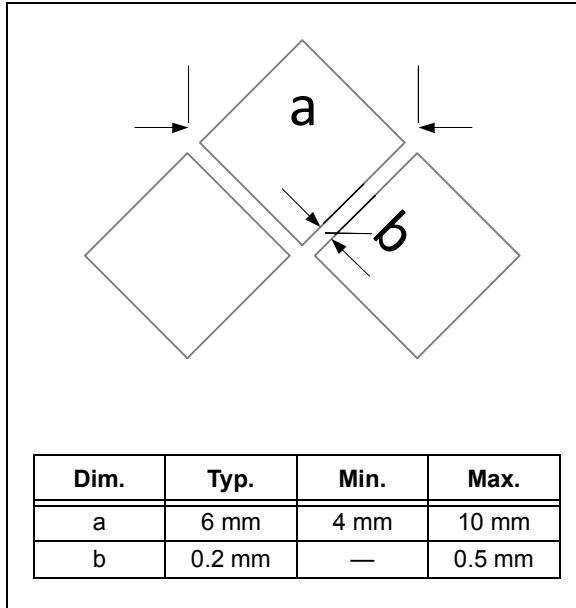

6.1.1 PROTOTYPING DESIGNS

Touch sensor designs typically require a thorough debugging phase to ensure a reliable product. If possible, it is suggested that flexible prototyping hardware be created with this in mind. A common example is providing external access to the communication lines for quick test and tuning while in-circuit.

6.1.2 SENSOR OVERLAY MATERIAL

To prevent saturation of sensor levels, a minimum overlay of 0.5 mm plastic or glass is required for proper operation of the device, even during a prototyping phase, even if this value is different than the final design.

Note: At no time should the device be expected to respond correctly to a user touching a bare PCB sensor.

6.1.3 OPERATION WITH AN LCD

MTCH6102 has integrated algorithms to detect and minimize the effects of noise, but proper care should always be taken in selecting an LCD and support components with a focus on reducing noise as much as possible. Since the interaction between the touch sensor and display is highly dependent upon the physical arrangement of the components, proper testing should always be executed with a fully integrated device. Please reference the appropriate projected capacitive touch screen manufacturer's integration guide for additional design considerations.

6.2 Sensor Layout Configuration

TABLE 6-1: REGISTERS ASSOCIATED WITH SENSOR LAYOUT CONFIGURATION

Address	Name	Description
0x20	NUMBEROFXCHANNELS	Number of channels used for X axis
0x21	NUMBEROFYCHANNELS	Number of channels used for Y axis

MTCH6102 is designed to work with sensors with a minimum of 3x3 sensor channels, and a total maximum of 15 channels. The number of channels on each axis is governed by the registers in [Table 6-1](#). For all sensor configurations, the following conditions must be met:

1. Channel layout must start at RX0.
2. Each axis must have the associated channels in either ascending or descending order.
3. No unconnected channel pins are allowed in the middle of a layout.

[Table 6-2](#) shows an example of each rule being broken by a 6x5 sensor layout, followed by the correct layout in the last column.

TABLE 6-2: EXAMPLE OF INCORRECT 6X5 SENSOR CONNECTIONS

	(1)	(2)	(3)	Correct
RX0		X0	X0	X0
RX1		X1	X1	X1
RX2		X2	X2	X2
RX3		X4	X3	X3
RX4	X0	X3	X4	X4
RX5	X1	X5	X5	X5
RX6	X2	Y0		Y0
RX7	X3	Y2		Y1
RX8	X4	Y1	Y0	Y2
RX9	X5	Y3	Y1	Y3
RX10	Y0	Y4	Y2	Y4
RX11	Y1		Y3	
RX12	Y2			
RX13	Y3		Y4	
RX14	Y4			

6.3 Sensor Output Resolution

MTCH6102 interpolates 64 discrete points between each channel and 32 points past the centerline of each edge. As a result, the maximum value in the TOUCHX and TOUCHY registers will be (64xNUMBEROFCHANNELS) on each axis. For the default 9x6 sensor, this results in a maximum resolution of 576x384.

MTCH6102

6.4 Sensor Orientation

To aid in PCB layout, the sensor can be oriented in any direction, have either axis reversed, or even have the axes swapped. The host controller must take into account the X/Y output and gesture orientation based on [Figure 6-2](#).

FIGURE 6-2: SENSOR ORIENTATION EXAMPLES

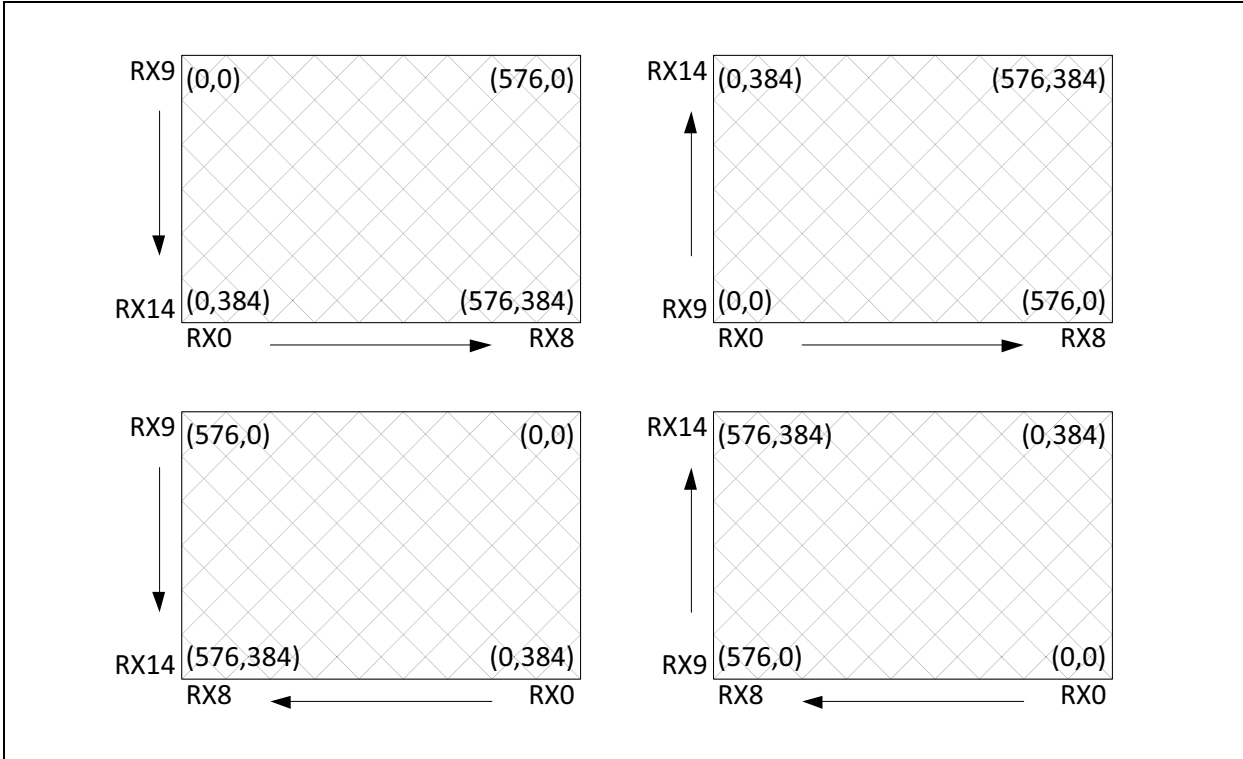

7.0 OPERATING MODES

MTCH6102 operates in multiple modes (see [Table 7-1](#)) governed by the MODE register (see [Register 7-1](#)).

TABLE 7-1: OPERATING MODE DESCRIPTIONS

Mode Name	Description	INT Behavior
Full	Full X/Y and gesture decoding occurs (Default mode)	Asserted if touch is present or if a change in touch status or a gesture have occurred
Touch	Full X/Y decoding only	Asserted if touch is present or if a change in touch status occurs
Gesture	Full X/Y and gesture decoding occurs, but INT is no longer asserted for touch data	Asserted for gestures only ⁽¹⁾
Raw	Raw-capacitance signals are stored in RAWADC registers, no decoding done. Channel selection and type of measurement is governed by the MODECON register	None
Standby	Device is no longer sensing or performing baseline tasks	None

Note 1: Data in TOUCH registers is still valid.

REGISTER 7-1: MODE: TOUCH DECODE MODE REGISTER

U-x	U-x	U-x	U-x	R/W-0	R/W-0	R/W-1	R/W-1
—	—	—	—	MODE<3:0>			
bit 7				bit 0			

Legend:

R = Readable bit	'1' = Bit is set	x = Bit is unknown	-n = Value after initialization (default)
W = Writable bit	'0' = Bit is cleared	U = Unimplemented bit	q = Conditional

bit 7-4 **Unimplemented:** Read as '0'

bit 3-0 **MODE<3:0>:** Touch Decoding mode bits

- 0000 = Standby
- 0001 = Gesture
- 0010 = Touch only
- 0011 = Full (touch and gesture)
- 01XX = Raw ADC

MTCH6102

REGISTER 7-2: MODECON: RAWADC MODE CONTROL REGISTER

R/W-0	R/W-0	R/W-0	R/W-0	R/W-0	R/W-0	R/W-0	R/W-0
TYPE<3:0>				CH<3:0>			
bit 7				bit 0			

Legend:

R = Readable bit	'1' = Bit is set	x = Bit is unknown	-n = Value after initialization (default)
W = Writable bit	'0' = Bit is cleared	U = Unimplemented bit	q = Conditional

bit 7-4 **TYPE<3:0>**: CVD Result Arithmetic bits

0000 = (1023 – Result1) + Result 2

0001 = Result 1 only

0010 = Result 2 only

bit 3-0 **CH<3:0>**: RX Sense Channel bits

0000 = RX0

..

..

1110 = RX14

1111 = Reserved, do not use

8.0 CONTROLLER COMMANDS

Various controller commands can be initiated by writing a '1' to the appropriate bit in the CMD register ([Register 8-1](#)). This bit will automatically be cleared after the command has been completed.

REGISTER 8-1: CMD: COMMAND REGISTER

R/W-0	R/W-0	R/W-0	U-x	R/W-0	U-x	U-x	R/W-0
NV	DEF	CFG	—	MFG	—	—	BS
bit 7							bit 0

Legend:

R = Readable bit	'1' = Bit is set	x = Bit is unknown	-n = Value after initialization (default)
W = Writable bit	'0' = Bit is cleared	U = Unimplemented bit	q = Conditional

- bit 7 **NV:** Nonvolatile Storage Write bit
- bit 6 **DEF:** Restore Controller to Default Configuration Values bit
- bit 5 **CFG:** Configure Controller bit (after parameters have been changed)
- bit 4 **Unimplemented:** Read as '0'
- bit 3 **MFG:** Execute Manufacturing Test bit
- bit 2-1 **Unimplemented:** Read as '0'
- bit 0 **BS:** Force Baseline bit (recalibration) to occur

MTCH6102

9.0 TOUCH FRAME CONTROL

Touch decoding is based around the concept of a touch *frame* that begins with acquisition, followed by decoding of the acquired values, and lastly a Sleep phase for power savings. The duration of the touch frame is governed by the current touch state, as well as the timing registers outlined in this section (see [Table 9-1](#)). [Figure 9-1](#) shows the interaction between these registers during a typical touch cycle.

TABLE 9-1: REGISTERS ASSOCIATED WITH TOUCH FRAME CONTROL

Address	Name	Description
0x25	ACTIVEPERIODL	Active Period
0x26	ACTIVEPERIODH	
0x27	IDLEPERIODL	Idle Period
0x28	IDLEPERIODH	
0x29	IDLETIMEOUT	Idle Timeout
0x2B	DEBOUNCEUP	Liftoff Debounce
0x2C	DEBOUNCEDOWN	Touch Down Debounce

Both active and idle period calculations are as shown in [Equation 9-1](#).

EQUATION 9-1:

$$\left(\frac{Duration(ms) \times 1000}{31} \right) + 1 = PERIOD$$

Typical frame rates have been computed for the user's convenience and are shown in [Table 9-2](#).

TABLE 9-2: EXAMPLE FRAME RATE PERIOD CALCULATIONS

Desired Rate (ms)	Period
10	0x0142
20	0x0284
50	0x064C
100	0x0C99

FIGURE 9-1: TOUCH FRAME TIMING

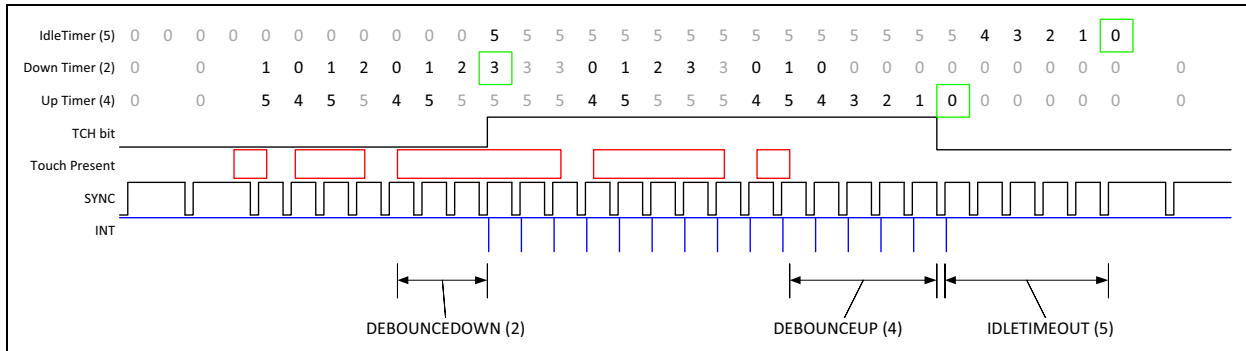

10.0 TOUCH DATA REGISTERS

REGISTER 10-1: TOUCHSTATE: CURRENT TOUCH STATE REGISTER

R/W-0	R/W-0	R/W-0	R/W-0	U-x	R/W-0	R/W-0	R/W-0
FRAME<3:0>				—	LRG	GES	TCH
bit 7							bit 0

Legend:

R = Readable bit	'1' = Bit is set	x = Bit is unknown	-n = Value after initialization (default)
W = Writable bit	'0' = Bit is cleared	U = Unimplemented bit	q = Conditional

- bit 7-4 **FRAME<3:0>**: Increments on Every Touch Frame
- bit 3 **Unimplemented**: Read as '0'
- bit 2 **LRG**: Large Activation is Present
- bit 1 **GES**: Gesture is Present
- bit 0 **TCH**: Touch is Present

REGISTER 10-2: TOUCHLSB REGISTER

R/W-0	R/W-0	R/W-0	R/W-0	R/W-0	R/W-0	R/W-0	R/W-0
TOUCHX<3:0>				TOUCHY<3:0>			
bit 7							bit 0

Legend:

R = Readable bit	'1' = Bit is set	x = Bit is unknown	-n = Value after initialization (default)
W = Writable bit	'0' = Bit is cleared	U = Unimplemented bit	q = Conditional

- bit 7-4 **TOUCHX<3:0>**: Current X Position (Least Significant bits)
- bit 3-0 **TOUCHY<3:0>**: Current Y Position (Least Significant bits)

TABLE 10-1: SUMMARY OF REGISTERS ASSOCIATED WITH TOUCH DATA

Address	Name	Bit 7	Bit 6	Bit 5	Bit 4	Bit 3	Bit 2	Bit 1	Bit 0
0x10	TOUCHSTATE	FRAME<3:0>				—	LRG	GES	TCH
0x11	TOUCHX	TOUCHX<11:4>							
0x12	TOUCHY	TOUCHY<11:4>							
0x13	TOUCHLSB	TOUCHX<3:0>				TOUCHY<3:0>			

MTCH6102

11.0 ACQUISITION AND TOUCH PARAMETERS

TABLE 11-1: REGISTERS ASSOCIATED WITH ACQUISITION AND TOUCH PARAMETERS

Address	Name	Default
0x22	SCANCOUNT	6
0x23	TOUCHTHRESHX	55
0x24	TOUCHTHRESHY	40
0x2A	HYSTERESIS	4
0x31	FILTERTYPE	2
0x32	FILTERSTRENGTH	1
0x35	LARGEACTIVATIONTHRESHL	0
0x36	LARGEACTIVATIONTHRESHH	0

11.1 SCANCOUNT

Every time a channel is scanned, it is scanned multiple times (SCANCOUNT) and summed. Increasing this number will give an inherent averaging effect, but at the cost of time and subsequently increased power consumption.

11.2 TOUCHTHRESHX/ TOUCHTHRESHY and HYSTERESIS

The presence of a touch is determined by the sensor channel's current value compared to the touch thresholds set by TOUCHTHRESHX (or TOUCHTHRESHY if the channel is on the Y axis).

The HYSTERESIS register contains a threshold modifier that acts as a dynamic threshold modifier depending on the state of the touch (higher without a touch). A single channel of touch is shown in Figure 11-1.

FIGURE 11-1: TOUCH THRESHOLD AND HYSTERESIS FUNCTIONALITY

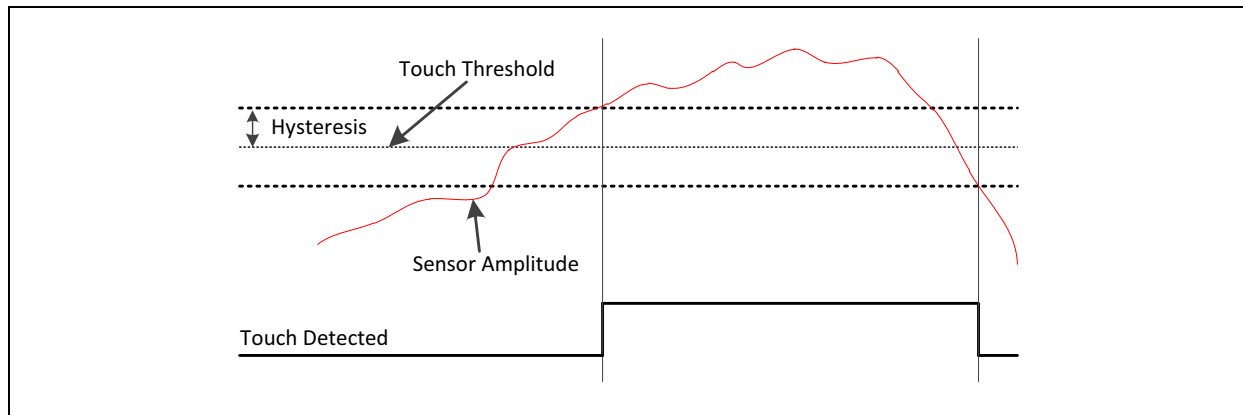

11.3 FILTERTYPE/FILTERSTRENGTH

As new sensor values are acquired, they are filtered based on the settings of the FILTERTYPE/FILTERSTRENGTH registers (see [Table 11-2](#)). Examples of the effects of each filter type are shown in [Figure 11-2](#).

TABLE 11-2: FILTERTYPE AND FILTERSTRENGTH DEFINITIONS

FILTERTYPE	FILTERSTRENGTH	Valid Values
0 – No Filter	N/A	—
1 – Median	Size of median window	3, 5, 7, 9
2 – IIR	Weighting of previous to current value	1, 2, 3 (1/2, 1/4 and 1/8 weighting accordingly)
3 – Average	Size of average window	1, 2, 3 (2, 4 and 8 accordingly)

FIGURE 11-2: FILTER EXAMPLES

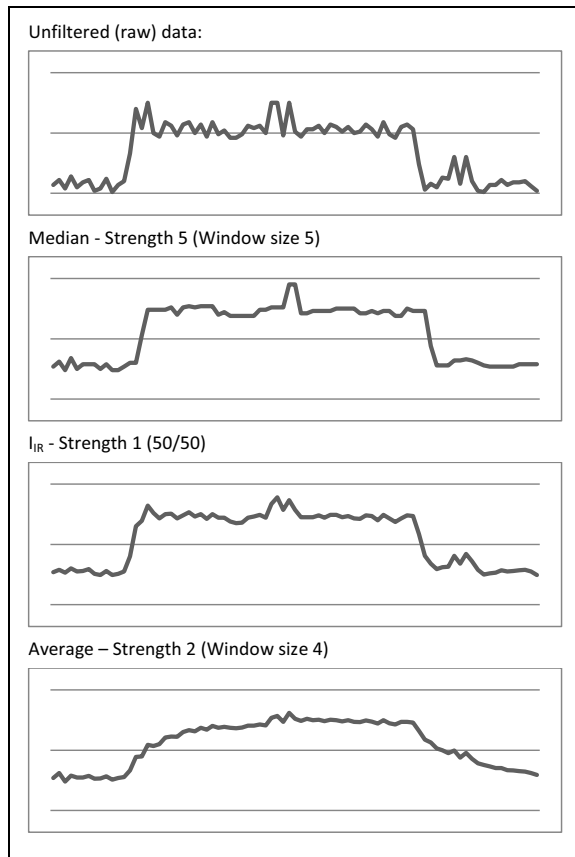

Choosing the correct filtering option for the user's application depends on the environment and sensor. Note that while the median filter has good characteristics, it is not the most efficient and will consume more power than other filters.

11.4 Large Activation

The LARGEACTIVATIONTHRESH registers provide a way to do simple rejection of signals that are too large to interpret. The amplitude of all sensor channels are added together and compared to this threshold. If greater, the LRG bit of the TOUCHSTATE register ([Register 10-1](#)) will be set.

Note that this does not affect touch decoding. In other words, even if the large activation threshold is breached, the controller will still decode the touch position as normal. The LRG bit merely serves to inform the host that the large activation threshold has been reached.

If this functionality is not intended to be used, this register should be set to zero, which will disable the large activation routines from running.

MTCH6102

12.0 COMPENSATION RAM

It is very common for a typical touch sensor to have non-uniform capacitive properties. To equalize the sensor, a series of coefficients can be written to the compensation RAM block. These coefficients represent a ratio that is applied to the individual channel in post-acquisition, before touch decoding occurs.

EQUATION 12-1: COMPENSATION RAM CALCULATION

$$\frac{[RAW\ VALUE] \times SENSORCOMP}{64} = [FINAL\ VALUE]$$

To obtain the correct compensation RAM values, the following procedure should be used:

1. Set all SENSORVALUES registers to zero (if necessary).
2. Record the peak values that occur in the SENSORVALUES registers when using the sensor under normal conditions (column A of [Table 12-1](#)).
3. Pick a commonly occurring value to represent the median of the set ('125').
4. Calculate the ratio of the peak value by dividing the median value by the peak (column B).
5. Multiply this value by 64 and truncate (column C). These are the compensation values that should be written to the SENSORCOMP registers. Please note that, if no compensation is required (value of '64', ratio of '1'), the register should be set to '0', to save time running compensation routines for that channel.
6. To see the expected output from the compensation values, follow [Equation 12-1](#) (result in column D).

TABLE 12-1: COMPENSATION RAM EXAMPLE CALCULATION

CH	A	B	C	D
0	102	1.225	78	124
1	113	1.106	71	125
2	118	1.059	68	125
3	125	1	64 (0)	125
4	125	1	64 (0)	125
5	128	0.977	63	126
6	132	0.947	61	126
7	160	0.781	50	125

13.0 BASELINE

Capacitive touch principles rely on analyzing a change in capacitance from a previously-stored baseline value (sometimes referred to as a calibration value). Baseline routines and behavior can be tweaked using the registers listed in [Table 13-1](#).

TABLE 13-1: REGISTERS ASSOCIATED WITH BASELINE

Address	Bit 7	Bit 6	Bit 5	Bit 4	Bit 3	Bit 2	Bit 1	Bit 0	Default
0x04	NV	DEF	CFG	-	MFG	-	-	BS	0
0x2D	BASEINTERVALL								10
0x2E	BASEINTERVALH								0
0x2F	BASEPOSFILTER								20
0x30	BASENEGFILTER								20
0x33	BASEFILTERTYPE								2
0x34	BASEFILTERSTRENGTH								1

13.1 BS Bit (CMD Register)

The BS bit forces the current sensor values to be stored as the baseline values, disregarding the constraints of BASEPOSFILTER and BASENEGFILTER.

13.2 BASEINTERVAL

It represents the number of touch frames between baseline sampling. Data that is sampled will be applied at the next baseline interval, provided that a touch has not occurred between the two.

If at any point, the touch threshold is breached, the baseline counter is reset, and a full interval without a touch must occur before baselining resumes.

Note that this value is specified in terms of the number of touch frames, so any changes in frame rate should take this into consideration by raising or lowering this interval accordingly.

13.3 BASEPOSFILTER/BASENEGFILTER

The positive and negative filters act as slew-rate limiters for a new baseline being applied. For example, if the new baseline value is larger than the previous by a value of 35, and the BASEPOSFILTER is set to 20 (default), the new baseline will only be increased by 20.

Use of these registers helps prevent unwanted spikes in the baseline value.

13.4 BASEFILTERTYPE/ BASEFILTERSTRENGTH

Baseline acquisition frames follow the same filter type and strength parameters as normal acquisition filters, defined in [Section 11.3 "FILTERTYPE/FILTER-STRENGTH"](#).

MTCH6102

14.0 GESTURE FEATURES AND PARAMETERS

Gesture detection and reporting is governed by the registers outlined in [Table 14-1](#).

TABLE 14-1: SUMMARY OF REGISTERS ASSOCIATED WITH GESTURES

Address	Name	Bit 7	Bit 6	Bit 5	Bit 4	Bit 3	Bit 2	Bit 1	Bit 0	Default
0x10	TOUCHSTATE	FRAME<3:0>				-	LRG	GES	TCH	N/A
0x14	GESTURESTATE	GESTURESTATE								0
0x15	GESTUREDIAG	GESTUREDIAG								0
0x37	HORIZONTALSWIPEDISTANCE	HORIZONTALSWIPEDISTANCE								64
0x38	VERTICALSWIPEDISTANCE	VERTICALSWIPEDISTANCE								64
0x39	SWIPEHOLDBOUNDARY	SWIPEHOLDBOUNDARY								25
0x3A	TAPDISTANCE	TAPDISTANCE								25
0x3B	DISTANCEBETWEENTAPS	DISTANCEBETWEENTAPS								64
0x3C	TAPHOLDTIME	TAPHOLDTIMEL								50
0x3D		TAPHOLDTIMEH								0
0x3E	GESTURECLICKTIME	GESTURECLICKTIME								12
0x3F	SWIPEHOLDTHRESH	SWIPEHOLDTHRESH								32
0x40	MINSWIPEVELOCITY	MINSWIPEVELOCITY								4
0x41	HORIZONTALGESTUREANGLE	HORIZONTALGESTUREANGLE								45
0x42	VERTICALGESTUREANGLE	VERTICALGESTUREANGLE								45

When a gesture is performed, the gesture ID will be placed in GESTURESTATE, and the GES bit of the TOUCHSTATE register will be set. Both of these items are cleared after reading the GESTURESTATE register. The GESTUREDIAG register contains a code explaining the logic behind the last operation of the gesture engine, primarily to help with debugging of the gesture parameters. These diagnostic codes are shown in [Register 14-2](#).

REGISTER 14-1: GESTURESTATE: CURRENT GESTURE STATE REGISTER

R/W-0	R/W-0	R/W-0	R/W-0	R/W-0	R/W-0	R/W-0	R/W-0
GESTURESTATE<7:0>							
bit 7							bit 0

Legend:

R = Readable bit	'1' = Bit is set	x = Bit is unknown	-n = Value after initialization (default)
W = Writable bit	'0' = Bit is cleared	U = Unimplemented bit	q = Conditional

bit 7-0	GESTURESTATE<7:0>:
	0x00 No Gesture Present
	0x10 Single Click
	0x11 Click and Hold
	0x20 Double Click
	0x31 Down Swipe
	0x32 Down Swipe and Hold
	0x41 Right Swipe
	0x42 Right Swipe and Hold
	0x51 Up Swipe
	0x52 Up Swipe and Hold
	0x61 Left Swipe
	0x62 Left Swipe and Hold

Please note that the gesture orientations listed in [Register 14-1](#) are correct for a default layout, with *right* moving on increasing X-axis channels, and *down* moving on increasing Y-axis channels. These default orientations are shown in [Figure 14-1](#). Depending on the application, the host may need to associate the gesture IDs differently.

FIGURE 14-1: GESTURE ORIENTATION

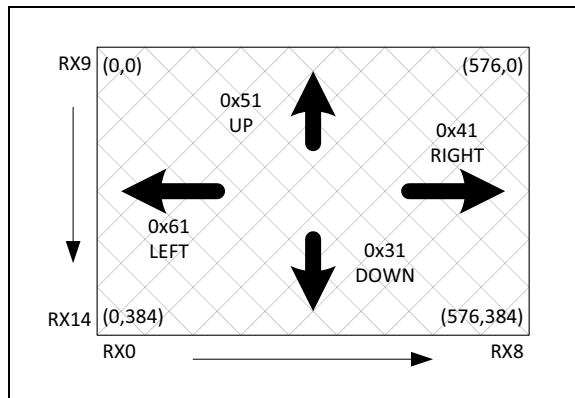

MTCH6102

REGISTER 14-2: GESTUREDIAG: GESTURE DIAGNOSTICS REGISTER

R/W-0	R/W-0	R/W-0	R/W-0	R/W-0	R/W-0	R/W-0	R/W-0
GESTUREDIAG<7:0>							
bit 7						bit 0	

Legend:

R = Readable bit	'1' = Bit is set	x = Bit is unknown	-n = Value after initialization (default)
W = Writable bit	'0' = Bit is cleared	U = Unimplemented bit	q = Conditional

bit 7-0

GESTUREDIAG<7:0>:

0x01	Click Timeout
0x02	Swipe Timeout
0x03	General Timeout
0x04	Click Threshold Exceeded
0x05	Swipe Threshold Exceeded
0x06	Swipe and Hold Threshold Exceeded
0x07	Swipe Opposite Direction Threshold Exceeded
0x08	Reserved
0x09	Swipe and Hold Value Exceeded
0x0A	Outside Swipe Angle

14.1 Gesture Tuning

FIGURE 14-2: GESTURE PARAMETER VISUALIZATION

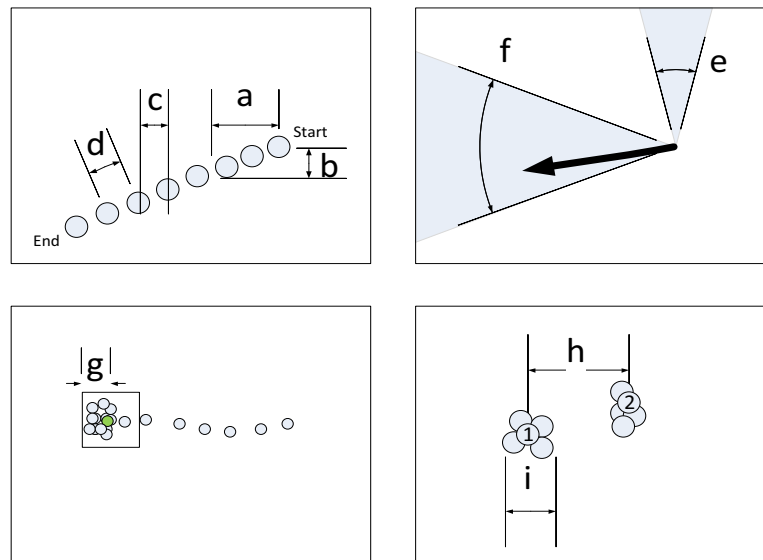

Legend:

1. HORIZONTALSWIPEDISTANCE/VERTICALSWIPEDISTANCE (**a/b**): Distance that a touch must move from the initial touchdown to be considered a *swipe*.
2. SWIPEHOLDTHRESH (**c**): Allowed movement in the opposite direction before a swipe is canceled.
3. MINSWIPEVELOCITY (**d**): Once a movement is classified as a *swipe*, this distance must be kept frame to frame before the swipe is classified as a *hold* (direction of travel is not important).
4. HORIZONTALGESTUREANGLE/VERTICALGESTUREANGLE (**f/e**): Angle in degrees allowed on horizontal (X-axis) and vertical (Y-axis) swipe movements. Swipes outside this parameter are detected, but not reported.
5. SWIPEHOLDBOUNDARY (**g**): Once a swipe is classified as a *hold*, movement must not exceed this parameter in any direction.
6. DISTANCEBETWEENTAPS (**h**): Distance allowed between two taps to be considered a *double click*.
7. TAPDISTANCE (**i**): Even when a sensor is pressed for a very short time (click), multiple frames of touch data occur. This parameter governs how close those individual touch points must be for a *click*.
8. TAPHOLDTIME (not shown): Duration of time a click must be held for to be considered a *click and hold*.
9. GESTURECLICKTIME (not shown): Maximum time between two clicks to be considered a *double click*.

15.0 CONFIGURING A NON-DEFAULT APPLICATION

When modifying sensor configuration parameters, the CFG bit of the CMD register must be set for the configuration to take effect. Setting this bit analyzes the following registers for validity and coerces them if necessary:

1. IDLEPERIOD/ACTIVEPERIOD
2. FILTERTYPE/FILTERSTRENGTH
3. BASELINEFILTERTYPE/FILTERSTRENGTH
4. NUMBEROFXCHANNELS/NUMBEROFYCHANNELS

Afterwards, the values take effect, and the sensor is base-lined and ready for use.

<p>Note: If the controller is not in Standby mode when changing configuration parameters, unreliable touch data may be generated until the CFG is set.</p>

Most applications will require custom parameters to be stored in the configuration RAM. The following methods are recommended for achieving this:

1. For permanent configuration: Either during manufacturing test or on first start-up, the host controller writes all configuration values to the controller, sets the CFG bit and stores them to NVRAM by using the NV bit.
2. For configuration on every power-up: The host writes all configuration data to the controller and sets the CFG bit on start-up.

16.0 MANUFACTURING TESTING

16.1 Automated Manufacturing Test

To start the automated manufacturing test, set the MFG bit of the CMD register. This test re-purposes the same RAM used for RAWADC commands to store the results. When the test is complete, the MFG bit will be cleared. The results of the manufacturing test are stored in the registers shown in [Table 16-1](#).

TABLE 16-1: MFG TEST RX LOOK-UP TABLE^(1,2)

Address	Bit 7	Bit 6	Bit 5	Bit 4	Bit 3	Bit 2	Bit 1	Bit 0
0XD0	—	—	RX13H	—	RX12H	RX11H	RX10H	RX9H
0XD1	—	—	RX13L	—	RX12L	RX11L	RX10L	RX9L
0XD2	—	—	RX8H	RX7H	RX6H	RX5H	RX4H	RX3H
0XD3	—	—	RX8L	RX7L	RX6L	RX5L	RX4L	RX3L
0XD4	RX2H	RX1H	RX0H	—	—	RX14H	—	—
0XD5	RX2L	RX1L	RX0L	—	—	RX14L	—	—

Note 1: RXnH: Pin was unable to set high and is likely shorted to VDD.

2: RXnL: Pin was unable to set low and is likely shorted to GND.

16.2 Sensor Integrity Testing

To test the integrity of both the touch sensor and the overlay for defects, the following test outline is advised:

1. For this test, a way to retrieve data from the MTCH6102 will be required. This can be either through a host controller, or the host controller can conduct the test itself with pre-set test values.
2. Collect the raw-capacitance values by reading the RAWVALUES registers under normal conditions on a set of at least 30 completely assembled sensors.
3. Use the information collected in step 2 to determine the variance and average value for each sensor channel. These values will be used as the standard by which manufactured sensors will need to fall within.
4. For each new sensor produced, compare the RAWVALUES to the range described in step 3. If the sensor falls out of this range, inspect the sensor assembly for defects.
5. To test for touch acquisition ability, repeat steps 1-4 with a known touch stimulus applied (e.g., simulated metal finger).

The above outline is intentionally generic, as manufacturing test setup will need to be modified for every application.

MTCH6102

17.0 MEMORY MAP

TABLE 17-1: CORE RAM MEMORY MAP

Addr.	Name	Core RAM									
		Bit 7	Bit 6	Bit 5	Bit 4	Bit 3	Bit 2	Bit 1	Bit 0	Default	
0x00	FWMAJOR	FW MAJOR									0x02
0x01	FWMINOR	FW MINOR									0x00
0x02	APPID	APPIDH <15:8>									0x00
0x03		APPIDL <7:0>									0x12
0x04	CMD	NV	DEF	CFG	—	MFG	—	—	BS	0x00	
0x05	MODE	—	—	—	—	MODE<3:0>				0x03	
0x06	MODECON	TYPE<3:0>				CH<3:0>				0x00	

TABLE 17-2: TOUCH RAM MEMORY MAP

Addr.	Name	Touch RAM									
		Bit 7	Bit 6	Bit 5	Bit 4	Bit 3	Bit 2	Bit 1	Bit 0	Default	
0x10	TOUCHSTATE	FRAME<3:0>				—	LRG	GES	TCH	0x00	
0x11	TOUCHX	TOUCHX<11:4>									0x00
0x12	TOUCHY	TOUCHY<11:4>									0x00
0x13	TOUCHLSB	TOUCHX<3:0>				TOUCHY<3:0>				0x00	
0x14	GESTURESTATE	GESTURESTATE									0x00
0x15	GESTUREDIAG	GESTUREDIAGNOSTIC									0x00

TABLE 17-3: COMPENSATION RAM MEMORY MAP

Addr.	Compensation RAM							
	Bit 7	Bit 6	Bit 5	Bit 4	Bit 3	Bit 2	Bit 1	Bit 0
0x50	SENSORCOMP<RX0>							
...	...							
0x5F	SENSORCOMP<RX14>							

TABLE 17-4: ACQUISITION RAM MEMORY MAP

Addr.	Acquisition RAM							
	Bit 7	Bit 6	Bit 5	Bit 4	Bit 3	Bit 2	Bit 1	Bit 0
0x80	SENSORVALUES<RX0>							
...	...							
0x8E	SENSORVALUES<RX14>							
—								
0x90	RAWVALUES<RX0>							
...	...							
0xAC	RAWVALUES<RX14>							
—								
0xB0	BASEVALUES<RX0>							
...	...							
0xCC	BASEVALUES<RX15>							
—								
0xD0	RAWADC<0>							
...	...							
0xEF	SENSORVALUES<31>							

MTCH6102

TABLE 17-5: CONFIGURATION RAM MEMORY MAP

Addr.	Configuration RAM								Default
	Bit 7	Bit 6	Bit 5	Bit 4	Bit 3	Bit 2	Bit 1	Bit 0	
0x20	NUMBEROFXCHANNELS								0x09
0x21	NUMBEROFYCHANNELS								0x06
0x22	SCANCOUNT								0x06
0x23	TOUCHTHRESHX								0x37
0x24	TOUCHTHRESHY								0x28
0x25	ACTIVEPERIODL								0x85
0x26	ACTIVEPERIODH								0x02
0x27	IDLEPERIODL								0x4C
0x28	IDLEPERIODH								0x06
0x29	IDLETIMEOUT								0x10
0x2A	HYSTERESIS								0x04
0x2B	DEBOUNCEUP								0x01
0x2C	DEBOUNCEDOWN								0x01
0x2D	BASEINTERVALL								0x0A
0x2E	BASEINTERVALH								0x00
0x2F	BASEPOSFILTER								0x14
0x30	BASENEGFILTER								0x14
0x31	FILTERTYPE								0x02
0x32	FILTERSTRENGTH								0x01
0x33	BASEFILTERTYPE								0x01
0x34	BASEFILTERSTRENGTH								0x05
0x35	LARGEACTIVATIONTHRESHL								0x00
0x36	LARGEACTIVATIONTHRESHH								0x00
0x37	HORIZONTALSWIPEDISTANCE								0x40
0x38	VERTICALSWIPEDISTANCE								0x40
0x39	SWIPEHOLDBOUNDARY								0x19
0x3A	TAPDISTANCE								0x19
0x3B	DISTANCEBETWEENTAPS								0x40
0x3C	TAPHOLDTIMEL								0x32
0x3D	TAPHOLDTIMEH								0x00
0x3E	GESTURECLICKTIME								0x0C
0x3F	SWIPEHOLDTHRESH								0x20
0x40	MINSWIPEVELOCITY								0x04
0x41	HORIZONTALGESTUREANGLE								0x2D
0x42	VERTICALGESTUREANGLE								0x2D
0x43	I ² CADDR								0x25

18.0 ELECTRICAL CHARACTERISTICS

18.1 Absolute Maximum Ratings^(†)

Ambient temperature under bias	-40°C to +85°C
Storage temperature	-65°C to +150°C
Voltage on pins with respect to V _{SS}	
on V _{DD} pin	-0.3V to +4.0V
on all other pins	0.3V to (V _{DD} + 0.3V)
Maximum current	
out of V _{SS} pin	340 mA
into V _{DD} pin	255 mA
Maximum output current	
sunk by any I/O pin	25 mA
sourced by any I/O pin	25 mA

Note: This device is sensitive to ESD damage and must be handled appropriately. Failure to properly handle and protect the device in an application may cause partial to complete failure of the device.

† NOTICE: Stresses above those listed under “Absolute Maximum Ratings” may cause permanent damage to the device. This is a stress rating only and functional operation of the device at those or any other conditions above those indicated in the operation listings of this specification is not implied. Exposure above maximum rating conditions for extended periods may affect device reliability.

18.2 Standard Operating Conditions

The standard operating conditions for any device are defined as:

Operating Voltage: $V_{DDMIN} \leq V_{DD} \leq V_{DDMAX}$
 Operating Temperature: $T_{A_MIN} \leq T_A \leq T_{A_MAX}$

V_{DD} — Operating Supply Voltage

MTCH6102

V _{DDMIN}	1.8V
V _{DDMAX}	3.6V

T_A — Operating Ambient Temperature Range

Industrial Temperature

T _{A_MIN}	-40°C
T _{A_MAX}	+85°C

MTCH6102

18.3 DC Characteristics

TABLE 18-1: OPERATING CONDITIONS

Rating	Min.	Typ.	Max.	Units
Supply Voltage	1.8	—	3.6	V
Supply Current (Full Active, No Frame Rate)	0.7	—	1.17	mA
Supply Current (Sleep)	<1			uA

TABLE 18-2: I/O PORTS

DC CHARACTERISTICS			Standard Operating Conditions (unless otherwise stated)					
Param. No.	Sym.	Characteristic	Min.	Typ.†	Max.	Units	Conditions	
D030 D031 D032 D033	V _{IL}	Input Low Voltage						
		I/O PORT:						
		with TTL buffer	—	—	0.15 V _{DD}	V	1.8V ≤ V _{DD} ≤ 4.5V	
		with Schmitt Trigger buffer	—	—	0.2 V _{DD}	V	2.0V ≤ V _{DD} ≤ 5.5V	
		with I ² C™ levels	—	—	0.3 V _{DD}	V		
		with SMBus levels	—	—	0.8	V	2.7V ≤ V _{DD} ≤ 5.5V	
D032		RESET, OSC1 (RC mode)	—	—	0.2 V _{DD}	V		
D033		OSC1 (HS mode)	—	—	0.3 V _{DD}	V		
D040 D041 D042 D043A D043B	V _{IH}	Input High Voltage						
		I/O ports:						
		with TTL buffer	0.25 V _{DD} + 0.8	—	—	V	1.8V ≤ V _{DD} ≤ 4.5V	
		with Schmitt Trigger buffer	0.8 V _{DD}	—	—	V	2.0V ≤ V _{DD} ≤ 5.5V	
		with I ² C levels	0.7 V _{DD}	—	—	V		
		with SMBus levels	2.1	—	—	V	2.7V ≤ V _{DD} ≤ 5.5V	
		D042	RESET	0.8 V _{DD}	—	—	V	
		D043A D043B	OSC1 (HS mode) OSC1 (RC mode)	0.7 V _{DD} 0.9 V _{DD}	— —	— —	V V	Note 1
D060 D061	I _{IL}	Input Leakage Current⁽²⁾						
		I/O ports	—	± 5	± 125	nA	V _{SS} ≤ V _{PIN} ≤ V _{DD} , Pin at high-impedance at 85°C	
D061		RESET ⁽²⁾	—	± 50	± 200	nA	V _{SS} ≤ V _{PIN} ≤ V _{DD} at 85°C	

* These parameters are characterized but not tested.

† Data in "Typ." column is at 3.0V, 25°C unless otherwise stated. These parameters are for design guidance only and are not tested.

Note 1: Negative current is defined as current sourced by the pin.

Note 2: The leakage current on the RESET pin is strongly dependent on the applied voltage level. The specified levels represent normal operating conditions. Higher leakage current may be measured at different input voltages.

TABLE 18-2: I/O PORTS (CONTINUED)

DC CHARACTERISTICS			Standard Operating Conditions (unless otherwise stated)				
Param. No.	Sym.	Characteristic	Min.	Typ.†	Max.	Units	Conditions
D070*	IPUR	Weak Pull-up Current					
			25	100	200	μA	VDD = 3.3V, VPIN = VSS
D080	VOL	Output Low Voltage					
		I/O ports	—	—	0.6	V	IOL = 6 mA, VDD = 3.3V IOL = 1.8 mA, VDD = 1.8V
D090	VOH	Output High Voltage					
		I/O ports	VDD - 0.7	—	—	V	I _{OH} = 3 mA, VDD = 3.3V I _{OH} = 1 mA, VDD = 1.8V
D101*	CIO	Capacitive Loading Specs on Output Pins					
		All I/O pins	—	—	50	pF	

* These parameters are characterized but not tested.

† Data in "Typ." column is at 3.0V, 25°C unless otherwise stated. These parameters are for design guidance only and are not tested.

Note 1: Negative current is defined as current sourced by the pin.

Note 2: The leakage current on the RESET pin is strongly dependent on the applied voltage level. The specified levels represent normal operating conditions. Higher leakage current may be measured at different input voltages.

MTCH6102

18.4 AC Characteristics and Timing Parameters

FIGURE 18-1: I²C™ BUS DATA TIMING

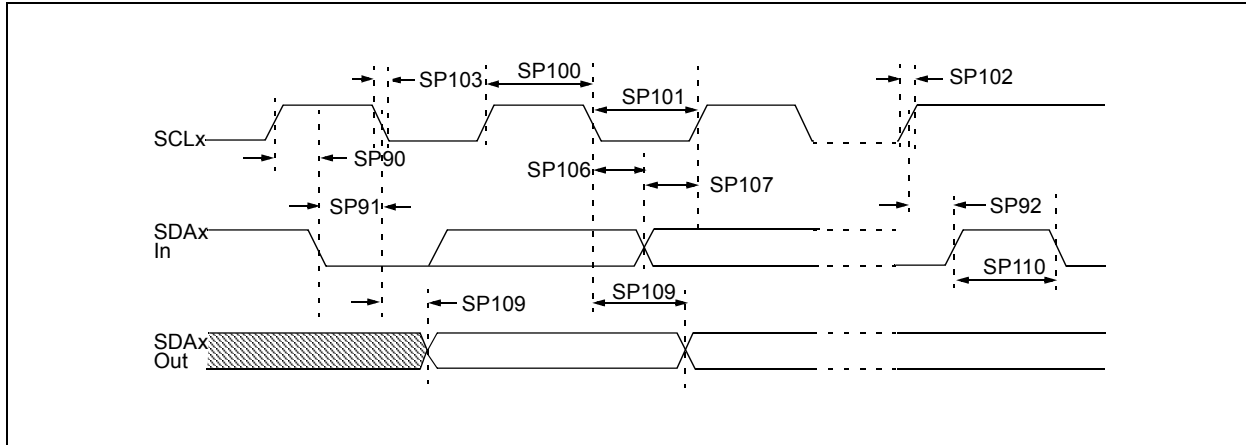

TABLE 18-3: I²C™ BUS DATA REQUIREMENTS

Param. No.	Symbol	Characteristic	Min.	Max.	Units	Conditions
SP100*	T _{HIGH}	Clock high time	400 kHz mode	0.6	—	μs
			SSP module	1.5T _{CY}	—	—
SP101*	T _{LOW}	Clock low time	400 kHz mode	1.3	—	μs
			SSP module	1.5T _{CY}	—	—
SP102*	T _R	SDAx and SCLx rise time	20 + 0.1C _B	300	ns	
SP103*	T _F	SDAx and SCLx fall time	20 + 0.1C _B	250	ns	
SP106*	T _{HD:DAT}	Data input hold time	0	0.9	μs	
SP107*	T _{SU:DAT}	Data input setup time	100	—	ns	
SP109*	T _{AA}	Output valid from clock	—	—	ns	
SP110*	T _{BUF}	Bus free time	1.3	—	μs	
SP111	C _B	Bus capacitive loading	—	400	pF	

* These parameters are characterized but not tested.

19.0 ORDERING INFORMATION

TABLE 19-1: ORDERING INFORMATION

Part Number	Pin Package	Packing
MTCH6102-I/SS	28-Lead SSOP (5.30 mm)	Tube
MTCH6102-I/MV	28-Lead UQFN (4x4x0.5 mm)	Tube
MTCH6102T-I/SS	28-Lead SSOP (5.30 mm)	T/R
MTCH6102T-I/MV	28-Lead UQFN (4x4x0.5 mm)	T/R

MTCH6102

20.0 PACKAGING INFORMATION

20.1 Package Marking Information

28-Lead Plastic Shrink Small Outline – 5.30 mm Body [SSOP]

28-Lead SSOP (5.30 mm)

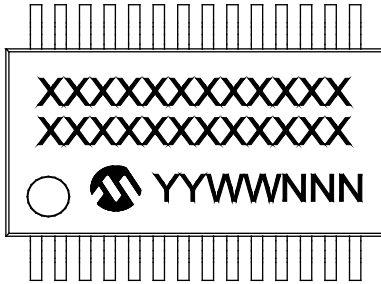

Example

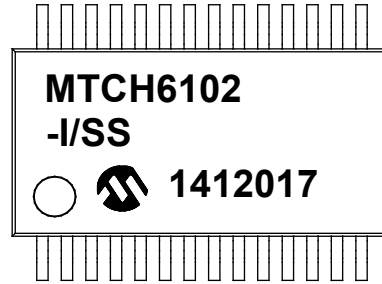

28-Lead Plastic Ultra Thin Quad Flat, No Lead Package – 4x4x0.5 mm Body [UQFN]

28-Lead UQFN (4x4x0.5 mm)

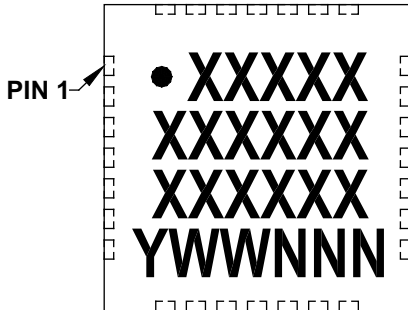

Example

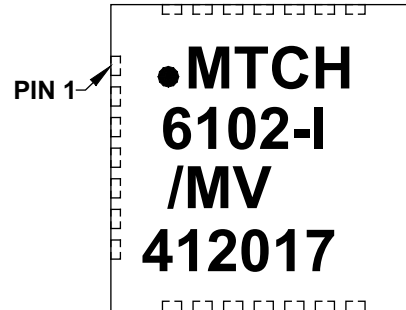

Legend:	XX...X	Customer-specific information
	Y	Year code (last digit of calendar year)
	YY	Year code (last 2 digits of calendar year)
	WW	Week code (week of January 1 is week '01')
	NNN	Alphanumeric traceability code
	(e3)	Pb-free JEDEC® designator for Matte Tin (Sn)
	*	This package is Pb-free. The Pb-free JEDEC designator (e3) can be found on the outer packaging for this package.
Note: In the event the full Microchip part number cannot be marked on one line, it will be carried over to the next line, thus limiting the number of available characters for customer-specific information.		

20.2 Package Details

The following sections give the technical details of the packages.

28-Lead Plastic Shrink Small Outline (SS) – 5.30 mm Body [SSOP]

Note: For the most current package drawings, please see the Microchip Packaging Specification located at <http://www.microchip.com/packaging>

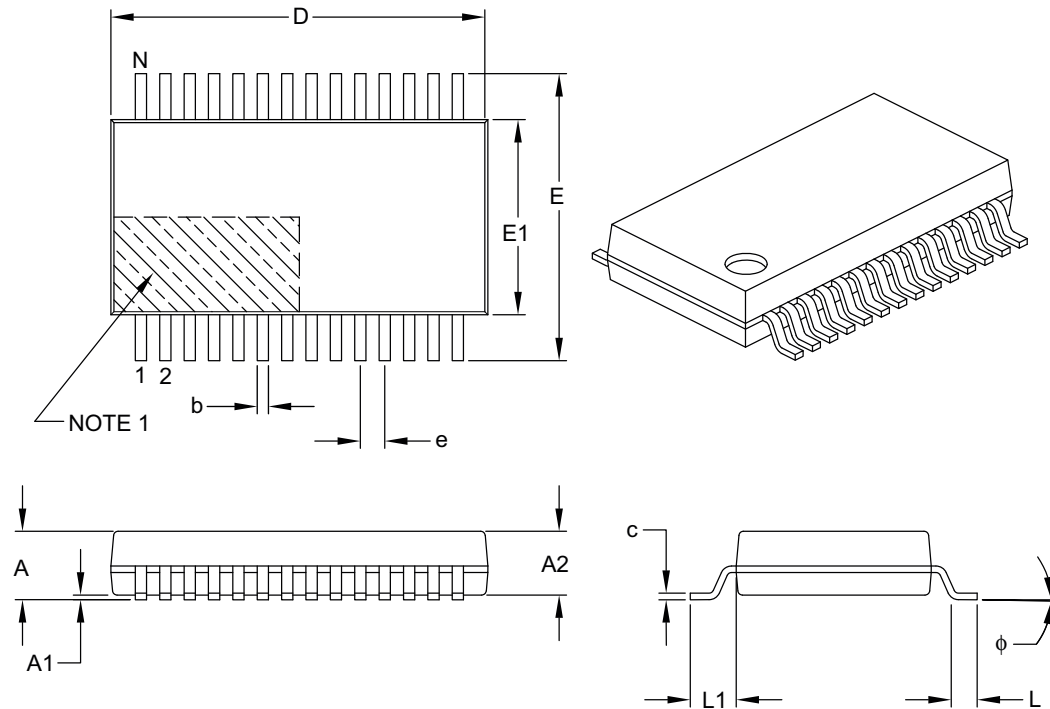

Dimension Limits	Units	MILLIMETERS		
		MIN	NOM	MAX
Number of Pins	N	28		
Pitch	e	0.65 BSC		
Overall Height	A	–	–	2.00
Molded Package Thickness	A2	1.65	1.75	1.85
Standoff	A1	0.05	–	–
Overall Width	E	7.40	7.80	8.20
Molded Package Width	E1	5.00	5.30	5.60
Overall Length	D	9.90	10.20	10.50
Foot Length	L	0.55	0.75	0.95
Footprint	L1	1.25 REF		
Lead Thickness	c	0.09	–	0.25
Foot Angle	ϕ	0°	4°	8°
Lead Width	b	0.22	–	0.38

Notes:

1. Pin 1 visual index feature may vary, but must be located within the hatched area.
2. Dimensions D and E1 do not include mold flash or protrusions. Mold flash or protrusions shall not exceed 0.20 mm per side.
3. Dimensioning and tolerancing per ASME Y14.5M.

BSC: Basic Dimension. Theoretically exact value shown without tolerances.

REF: Reference Dimension, usually without tolerance, for information purposes only.

Microchip Technology Drawing C04-073B

MTCH6102

28-Lead Plastic Shrink Small Outline (SS) - 5.30 mm Body [SSOP]

Note: For the most current package drawings, please see the Microchip Packaging Specification located at <http://www.microchip.com/packaging>

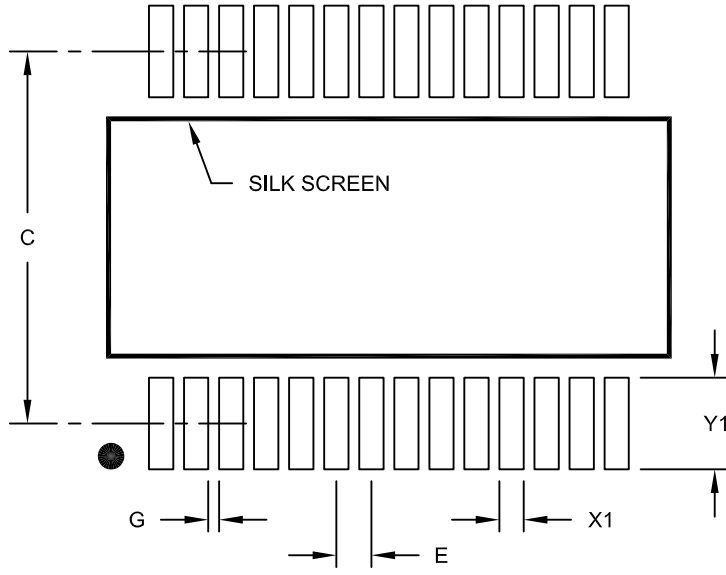

RECOMMENDED LAND PATTERN

Dimension Limits	Units	MILLIMETERS		
		MIN	NOM	MAX
Contact Pitch	E	0.65 BSC		
Contact Pad Spacing	C		7.20	
Contact Pad Width (X28)	X1			0.45
Contact Pad Length (Y1)	Y1			1.75
Distance Between Pads	G	0.20		

Notes:

1. Dimensioning and tolerancing per ASME Y14.5M

BSC: Basic Dimension. Theoretically exact value shown without tolerances.

Microchip Technology Drawing No. C04-2073A

28-Lead Plastic Ultra Thin Quad Flat, No Lead Package (MV) – 4x4x0.5 mm Body [UQFN]

Note: For the most current package drawings, please see the Microchip Packaging Specification located at <http://www.microchip.com/packaging>

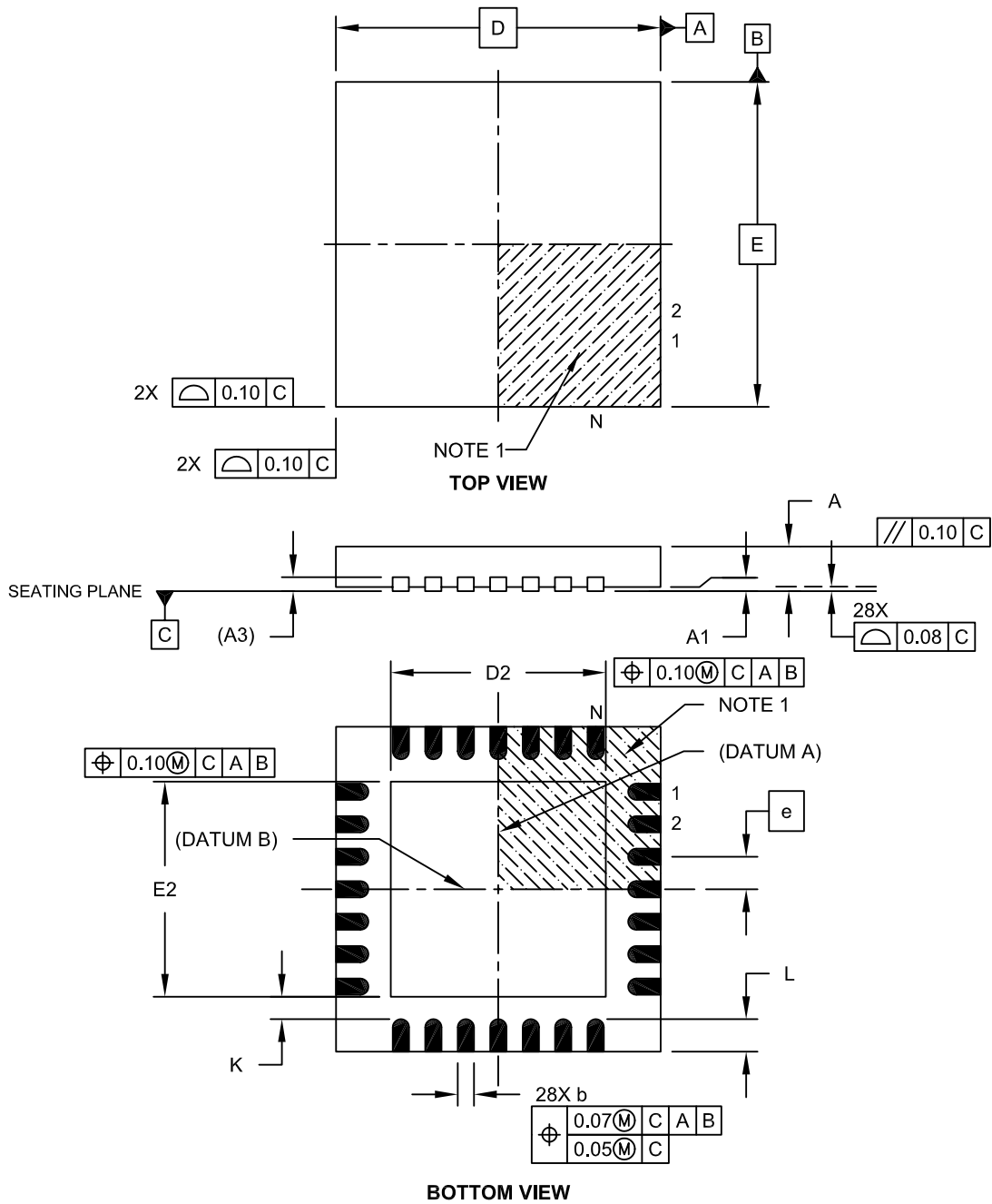

Microchip Technology Drawing C04-152A Sheet 1 of 2

MTCH6102

28-Lead Plastic Ultra Thin Quad Flat, No Lead Package (MV) – 4x4x0.5 mm Body [UQFN]

Note: For the most current package drawings, please see the Microchip Packaging Specification located at <http://www.microchip.com/packaging>

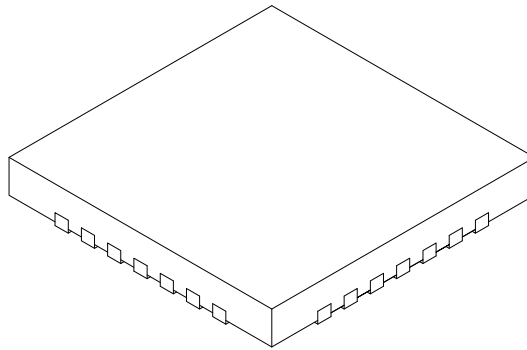

Units		MILLIMETERS		
Dimension Limits		MIN	NOM	MAX
Number of Pins	N	28		
Pitch	e	0.40 BSC		
Overall Height	A	0.45	0.50	0.55
Standoff	A1	0.00	0.02	0.05
Contact Thickness	A3	0.127 REF		
Overall Width	E	4.00 BSC		
Exposed Pad Width	E2	2.55	2.65	2.75
Overall Length	D	4.00 BSC		
Exposed Pad Length	D2	2.55	2.65	2.75
Contact Width	b	0.15	0.20	0.25
Contact Length	L	0.30	0.40	0.50
Contact-to-Exposed Pad	K	0.20	-	-

Notes:

1. Pin 1 visual index feature may vary, but must be located within the hatched area.
2. Package is saw singulated.
3. Dimensioning and tolerancing per ASME Y14.5M.

BSC: Basic Dimension. Theoretically exact value shown without tolerances.

REF: Reference Dimension, usually without tolerance, for information purposes only.

Microchip Technology Drawing C04-152A Sheet 2 of 2

28-Lead Ultra Thin Plastic Quad Flat, No Lead Package (MV) - 4x4 mm Body [UQFN] With 0.40 mm Contact Length

Note: For the most current package drawings, please see the Microchip Packaging Specification located at <http://www.microchip.com/packaging>

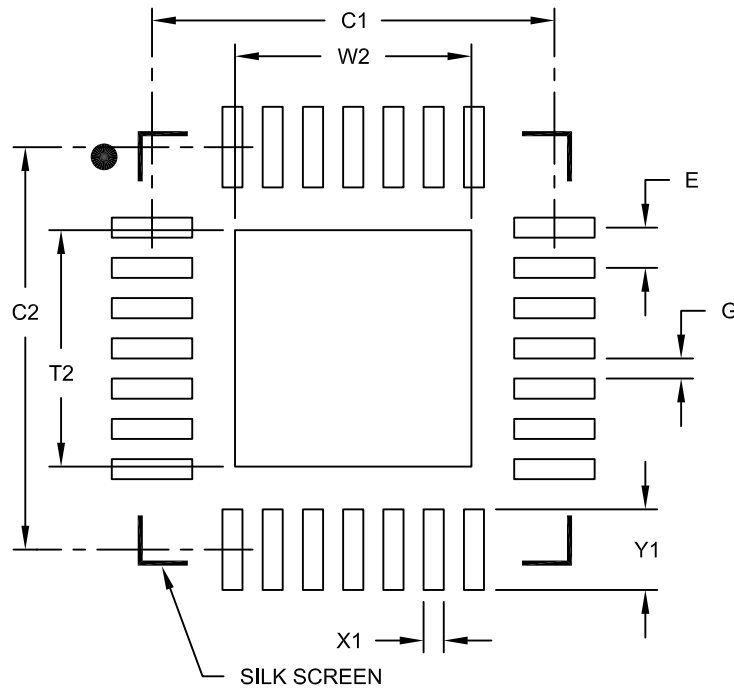

RECOMMENDED LAND PATTERN

Dimension Limits	Units	MILLIMETERS		
		MIN	NOM	MAX
Contact Pitch	E	0.40 BSC		
Optional Center Pad Width	W2			2.35
Optional Center Pad Length	T2			2.35
Contact Pad Spacing	C1		4.00	
Contact Pad Spacing	C2		4.00	
Contact Pad Width (X28)	X1			0.20
Contact Pad Length (X28)	Y1			0.80
Distance Between Pads	G	0.20		

Notes:

1. Dimensioning and tolerancing per ASME Y14.5M

BSC: Basic Dimension. Theoretically exact value shown without tolerances.

Microchip Technology Drawing No. C04-2152A

MTCH6102

APPENDIX A: DATA SHEET REVISION HISTORY

Revision A (03/2014)

Initial release of the document.

THE MICROCHIP WEB SITE

Microchip provides online support via our WWW site at www.microchip.com. This web site is used as a means to make files and information easily available to customers. Accessible by using your favorite Internet browser, the web site contains the following information:

- **Product Support** – Data sheets and errata, application notes and sample programs, design resources, user's guides and hardware support documents, latest software releases and archived software
- **General Technical Support** – Frequently Asked Questions (FAQ), technical support requests, online discussion groups, Microchip consultant program member listing
- **Business of Microchip** – Product selector and ordering guides, latest Microchip press releases, listing of seminars and events, listings of Microchip sales offices, distributors and factory representatives

CUSTOMER CHANGE NOTIFICATION SERVICE

Microchip's customer notification service helps keep customers current on Microchip products. Subscribers will receive e-mail notification whenever there are changes, updates, revisions or errata related to a specified product family or development tool of interest.

To register, access the Microchip web site at www.microchip.com. Under "Support", click on "Customer Change Notification" and follow the registration instructions.

CUSTOMER SUPPORT

Users of Microchip products can receive assistance through several channels:

- Distributor or Representative
- Local Sales Office
- Field Application Engineer (FAE)
- Technical Support

Customers should contact their distributor, representative or Field Application Engineer (FAE) for support. Local sales offices are also available to help customers. A listing of sales offices and locations is included in the back of this document.

Technical support is available through the web site at: <http://microchip.com/support>

Note the following details of the code protection feature on Microchip devices:

- Microchip products meet the specification contained in their particular Microchip Data Sheet.
- Microchip believes that its family of products is one of the most secure families of its kind on the market today, when used in the intended manner and under normal conditions.
- There are dishonest and possibly illegal methods used to breach the code protection feature. All of these methods, to our knowledge, require using the Microchip products in a manner outside the operating specifications contained in Microchip's Data Sheets. Most likely, the person doing so is engaged in theft of intellectual property.
- Microchip is willing to work with the customer who is concerned about the integrity of their code.
- Neither Microchip nor any other semiconductor manufacturer can guarantee the security of their code. Code protection does not mean that we are guaranteeing the product as "unbreakable."

Code protection is constantly evolving. We at Microchip are committed to continuously improving the code protection features of our products. Attempts to break Microchip's code protection feature may be a violation of the Digital Millennium Copyright Act. If such acts allow unauthorized access to your software or other copyrighted work, you may have a right to sue for relief under that Act.

Information contained in this publication regarding device applications and the like is provided only for your convenience and may be superseded by updates. It is your responsibility to ensure that your application meets with your specifications. MICROCHIP MAKES NO REPRESENTATIONS OR WARRANTIES OF ANY KIND WHETHER EXPRESS OR IMPLIED, WRITTEN OR ORAL, STATUTORY OR OTHERWISE, RELATED TO THE INFORMATION, INCLUDING BUT NOT LIMITED TO ITS CONDITION, QUALITY, PERFORMANCE, MERCHANTABILITY OR FITNESS FOR PURPOSE. Microchip disclaims all liability arising from this information and its use. Use of Microchip devices in life support and/or safety applications is entirely at the buyer's risk, and the buyer agrees to defend, indemnify and hold harmless Microchip from any and all damages, claims, suits, or expenses resulting from such use. No licenses are conveyed, implicitly or otherwise, under any Microchip intellectual property rights.

Trademarks

The Microchip name and logo, the Microchip logo, dsPIC, FlashFlex, KEELOQ, KEELOQ logo, MPLAB, PIC, PICmicro, PICSTART, PIC³² logo, rfPIC, SST, SST Logo, SuperFlash and UNI/O are registered trademarks of Microchip Technology Incorporated in the U.S.A. and other countries.

FilterLab, Hampshire, HI-TECH C, Linear Active Thermistor, MTP, SEEVAL and The Embedded Control Solutions Company are registered trademarks of Microchip Technology Incorporated in the U.S.A.

Silicon Storage Technology is a registered trademark of Microchip Technology Inc. in other countries.

Analog-for-the-Digital Age, Application Maestro, BodyCom, chipKIT, chipKIT logo, CodeGuard, dsPICDEM, dsPICDEM.net, dsPICworks, dsSPEAK, ECAN, ECONOMONITOR, FanSense, HI-TIDE, In-Circuit Serial Programming, ICSP, Mindi, MiWi, MPASM, MPF, MPLAB Certified logo, MPLIB, MPLINK, mTouch, Omniscient Code Generation, PICC, PICC-18, PICDEM, PICDEM.net, PICKit, PICtail, REAL ICE, rLAB, Select Mode, SQI, Serial Quad I/O, Total Endurance, TSHARC, UniWinDriver, WiperLock, ZENA and Z-Scale are trademarks of Microchip Technology Incorporated in the U.S.A. and other countries.

SQTP is a service mark of Microchip Technology Incorporated in the U.S.A.

GestIC and ULPP are registered trademarks of Microchip Technology Germany II GmbH & Co. KG, a subsidiary of Microchip Technology Inc., in other countries.

All other trademarks mentioned herein are property of their respective companies.

© 2014, Microchip Technology Incorporated, Printed in the U.S.A., All Rights Reserved.

 Printed on recycled paper.

ISBN: 978-1-63276-043-2

QUALITY MANAGEMENT SYSTEM
CERTIFIED BY DNV
== ISO/TS 16949 ==

Microchip received ISO/TS-16949:2009 certification for its worldwide headquarters, design and wafer fabrication facilities in Chandler and Tempe, Arizona; Gresham, Oregon and design centers in California and India. The Company's quality system processes and procedures are for its PIC[®] MCUs and dsPIC[®] DSCs, KEELOQ[®] code hopping devices, Serial EEPROMs, microperipherals, nonvolatile memory and analog products. In addition, Microchip's quality system for the design and manufacture of development systems is ISO 9001:2000 certified.



MICROCHIP

Worldwide Sales and Service

AMERICAS

Corporate Office
2355 West Chandler Blvd.
Chandler, AZ 85224-6199
Tel: 480-792-7200
Fax: 480-792-7277
Technical Support:
<http://www.microchip.com/support>
Web Address:
www.microchip.com

Atlanta
Duluth, GA
Tel: 678-957-9614
Fax: 678-957-1455

Austin, TX
Tel: 512-257-3370

Boston
Westborough, MA
Tel: 774-760-0087
Fax: 774-760-0088

Chicago
Itasca, IL
Tel: 630-285-0071
Fax: 630-285-0075

Cleveland
Independence, OH
Tel: 216-447-0464
Fax: 216-447-0643

Dallas
Addison, TX
Tel: 972-818-7423
Fax: 972-818-2924

Detroit
Novi, MI
Tel: 248-848-4000

Houston, TX
Tel: 281-894-5983

Indianapolis
Noblesville, IN
Tel: 317-773-8323
Fax: 317-773-5453

Los Angeles
Mission Viejo, CA
Tel: 949-462-9523
Fax: 949-462-9608

New York, NY
Tel: 631-435-6000

San Jose, CA
Tel: 408-735-9110

Canada - Toronto
Tel: 905-673-0699
Fax: 905-673-6509

ASIA/PACIFIC

Asia Pacific Office
Suites 3707-14, 37th Floor
Tower 6, The Gateway
Harbour City, Kowloon
Hong Kong
Tel: 852-2943-5100
Fax: 852-2401-3431

Australia - Sydney
Tel: 61-2-9868-6733
Fax: 61-2-9868-6755

China - Beijing
Tel: 86-10-8569-7000
Fax: 86-10-8528-2104

China - Chengdu
Tel: 86-28-8665-5511
Fax: 86-28-8665-7889

China - Chongqing
Tel: 86-23-8980-9588
Fax: 86-23-8980-9500

China - Hangzhou
Tel: 86-571-8792-8115
Fax: 86-571-8792-8116

China - Hong Kong SAR
Tel: 852-2943-5100
Fax: 852-2401-3431

China - Nanjing
Tel: 86-25-8473-2460
Fax: 86-25-8473-2470

China - Qingdao
Tel: 86-532-8502-7355
Fax: 86-532-8502-7205

China - Shanghai
Tel: 86-21-5407-5533
Fax: 86-21-5407-5066

China - Shenyang
Tel: 86-24-2334-2829
Fax: 86-24-2334-2393

China - Shenzhen
Tel: 86-755-8864-2200
Fax: 86-755-8203-1760

China - Wuhan
Tel: 86-27-5980-5300
Fax: 86-27-5980-5118

China - Xian
Tel: 86-29-8833-7252
Fax: 86-29-8833-7256

China - Xiamen
Tel: 86-592-2388138
Fax: 86-592-2388130

China - Zhuhai
Tel: 86-756-3210040
Fax: 86-756-3210049

ASIA/PACIFIC

India - Bangalore
Tel: 91-80-3090-4444
Fax: 91-80-3090-4123

India - New Delhi
Tel: 91-11-4160-8631
Fax: 91-11-4160-8632

India - Pune
Tel: 91-20-3019-1500

Japan - Osaka
Tel: 81-6-6152-7160
Fax: 81-6-6152-9310

Japan - Tokyo
Tel: 81-3-6880-3770
Fax: 81-3-6880-3771

Korea - Daegu
Tel: 82-53-744-4301
Fax: 82-53-744-4302

Korea - Seoul
Tel: 82-2-554-7200
Fax: 82-2-558-5932 or
82-2-558-5934

Malaysia - Kuala Lumpur
Tel: 60-3-6201-9857
Fax: 60-3-6201-9859

Malaysia - Penang
Tel: 60-4-227-8870
Fax: 60-4-227-4068

Philippines - Manila
Tel: 63-2-634-9065
Fax: 63-2-634-9069

Singapore
Tel: 65-6334-8870
Fax: 65-6334-8850

Taiwan - Hsin Chu
Tel: 886-3-5778-366
Fax: 886-3-5770-955

Taiwan - Kaohsiung
Tel: 886-7-213-7830

Taiwan - Taipei
Tel: 886-2-2508-8600
Fax: 886-2-2508-0102

Thailand - Bangkok
Tel: 66-2-694-1351
Fax: 66-2-694-1350

EUROPE

Austria - Wels
Tel: 43-7242-2244-39
Fax: 43-7242-2244-393

Denmark - Copenhagen
Tel: 45-4450-2828
Fax: 45-4485-2829

France - Paris
Tel: 33-1-69-53-63-20
Fax: 33-1-69-30-90-79

Germany - Dusseldorf
Tel: 49-2129-3766400

Germany - Munich
Tel: 49-89-627-144-0
Fax: 49-89-627-144-44

Germany - Pforzheim
Tel: 49-7231-424750

Italy - Milan
Tel: 39-0331-742611
Fax: 39-0331-466781

Italy - Venice
Tel: 39-049-7625286

Netherlands - Drunen
Tel: 31-416-690399
Fax: 31-416-690340

Poland - Warsaw
Tel: 48-22-3325737

Spain - Madrid
Tel: 34-91-708-08-90
Fax: 34-91-708-08-91

Sweden - Stockholm
Tel: 46-8-5090-4654

UK - Wokingham
Tel: 44-118-921-5800
Fax: 44-118-921-5820

03/25/14