



## Piezoelectric Powder Level Sensors

# TSP<sub>series</sub>

---

---

# Piezoelectric Powder Level Sensors

Product compatible with RoHS directive

## Overview of the TSP series

### FEATURES

TDK's piezoelectric powder level sensor, which uses a sensor element consisting of piezoelectric ceramic, was originally developed by TDK. The sensor detects the presence of powder when the sensor element, which its built-in oscillating circuit causes to vibrate, comes into contact with powder and the vibrational conditions are altered.

- This is a unique sensor by TDK that employs a piezoelectric ceramic sensor element.
- The exterior has a die cast finish that makes the sensor highly resistant to effects caused by external vibrations, and provides stable detection characteristics.
- The sensor can detect both magnetic and non-magnetic powders.
- The sensor can be easily mounted to a wide range of locations.
- Compact and low-cost.

### APPLICATION

- Toner detectors for copiers, laser beam printers, etc.
- Detectors for other types of powders.

### PART NUMBER CONSTRUCTION

TSP	1	5	D	10	C-01
Series name	Sensor diameter (mm)	Driving voltage (V)	Type	Shape of case	Identifying control number
	1   $\phi 11$	5   5	D   Assembly A   Element		

### PRODUCT LINEUP

#### ASSEMBLY (BUILT-IN OSCILLATION/CONTROL CIRCUITS)

Type	Electrical characteristics			Size		
	Driving voltage (V)	Output voltage (V)max.	Output signal	Detection portion (mm)	Body width (mm)	Body length (mm)
TSP15D10C-01	5	5	High/Low	$\phi 11 \times 4$	17	14



#### ELEMENT (SEPARATED OSCILLATION/CONTROL CIRCUITS)

Type	Electrical characteristics			Size		
	Resonance frequency (kHz)	Resonant impedance ( $\Omega$ )	Phase (deg)	Detection portion (mm)	Body width (mm)	Body length (mm)
TSP15A10C-17	6	1000	0 to 80	$\phi 11 \times 4$	17	14



 Background yellow: The product is not recommended to a new design.

RoHS Directive Compliant Product: See the following for more details. <https://product.tdk.com/info/en/environment/rohs/index.html>

 Please be sure to request delivery specifications that provide further details on the features and specifications of the products for proper and safe use. Please note that the contents may change without any prior notice due to reasons such as upgrading.

## Assembly Built-in Oscillation/Control Circuits

## TSP15D10C-01

## SHAPE &amp; DIMENSIONS

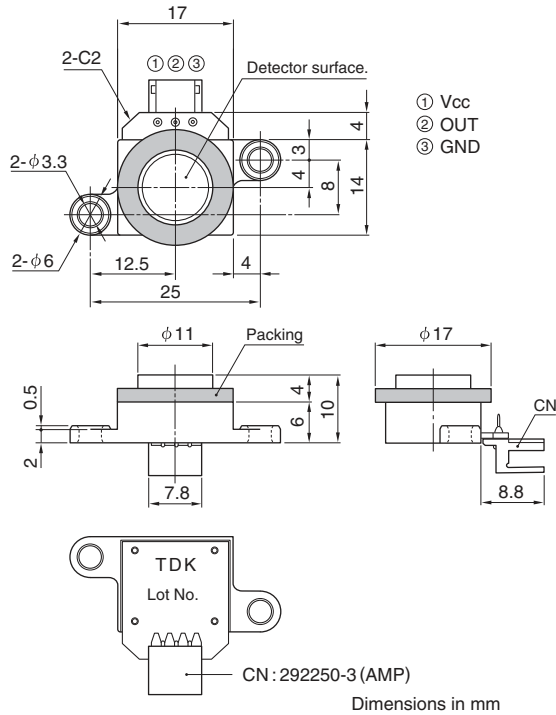

## EXAMPLE CIRCUIT CONNECTION

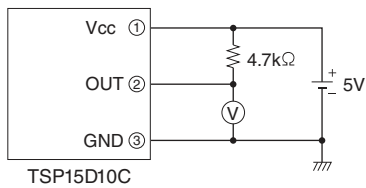

## TYPICAL ELECTRICAL CHARACTERISTICS

Driving voltage Vcc	(V)	5±0.5
Input current	(mA)	20 max.
Sensor level*	(mm)	5±3
Output voltage High	(V)	4.5 min.
Output voltage Low	(V)	0.5 max.
Operating temperature range	(°C)	0 to 50

\* Sensor level: in the model described below in which the amount of powder increases, the value of A at the moment when the sensor detects the presence of powder (the measurement from the top surface of the powder to the upper end of the sensor part of this product).

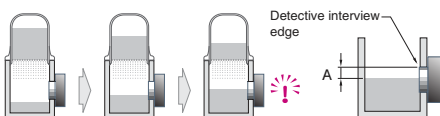

Element Separated Oscillation/Control Circuits

# TSP15A10C-17

## SHAPE & DIMENSIONS

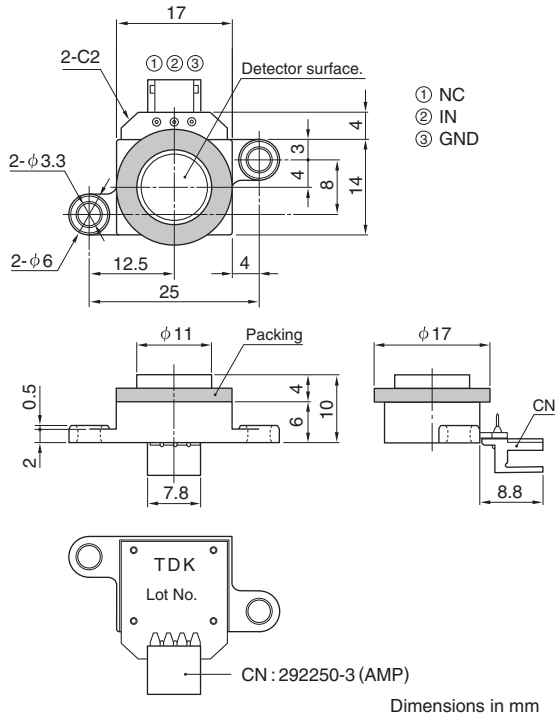

## EXAMPLE CIRCUIT CONNECTION

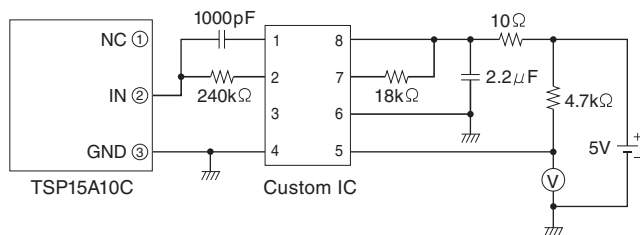

## TYPICAL ELECTRICAL CHARACTERISTICS

Resonance frequency	(kHz)	6±1
Resonant impedance	(Ω)	1000±500
Phase	(deg)	0 to 80
Capacitance	(nF)	6.5±20% [at 1kHz]
Operating temperature range	(°C)	0 to 50

# TSP series

## ■ Handling Precautions

### For TSP series products of all types

- Please request a delivery specification form containing more detailed information on characteristics and specifications so as to ensure correct and safe use of the products.

#### [Storage Environment]

- Check the standards concerning the storage conditions described in the delivery specifications of the products, and store them in accordance with the standards.

#### [Usage Environment/Operating Conditions]

- As for usage environment conditions and operating conditions of the products, check the standards concerning the usage environment conditions and operating conditions described in the delivery specifications, and use the products in accordance with the standards.

#### [Handling]

- Do not apply mechanical pressure on the sensing surface of the product, as a very thin metal plate and piezoelectric element are used for the sensing surface.

### D Type (Built-in Oscillation / Control Circuits)

#### [Handling]

- The products are susceptible to surges and electrostatic discharge. Take measures such as the use of a protective circuit if necessary.
- Make sure that the OFF time of the sensor's power supply is at least 1 msec to prevent a malfunctioning of the internal IC.

## ■ Other Requests/Notices

- We do not assume any responsibility for any damage caused by the use of our products exceeding the scope or conditions defined in the delivery specifications.
- Specifications of the products in this catalog are subject to change without notice due to improvements or other reasons. In addition, supply of the products may be cancelled without notice.