

PART NUMBER	REV	FIRST USED
680167-1	C	122500-1
680167-2	C	565435-5
680167-3	C	354500-1

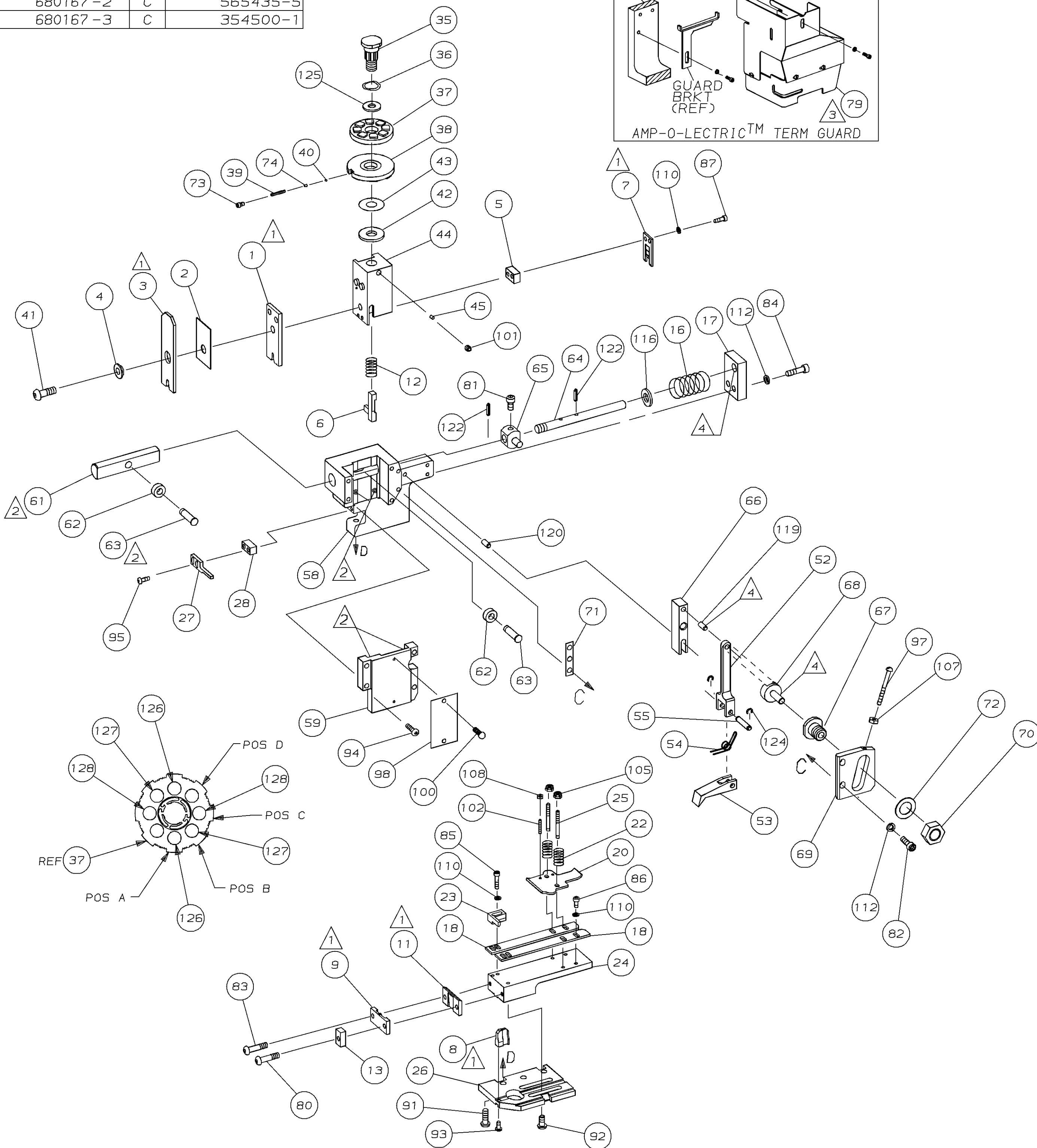
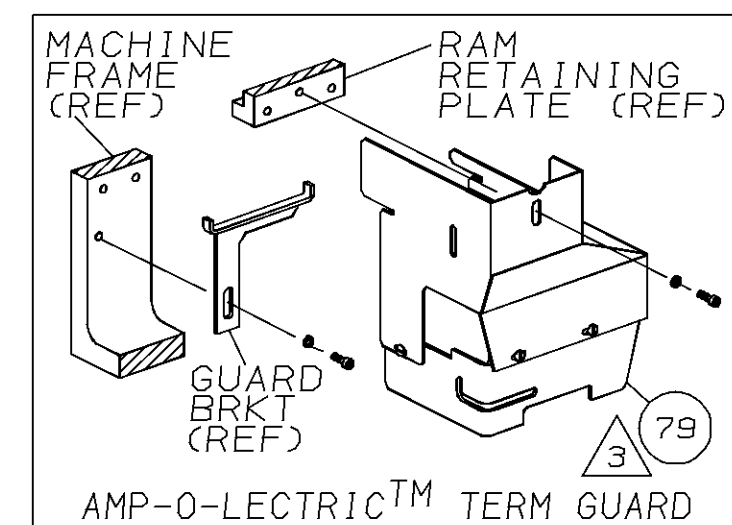

TERMINAL NAME: 9.5 SERIES FASTIN - FASTON™ REC						
963851						
CRIMPING DATA						
PAD LTR	CRIMP HEIGHT		WIRE SIZE			
A	.134 ±.002	[3.4 ±0.05mm]	10mm ²			
B	.122 ±.002	[3.09 ±0.05mm]	8 mm ²			
C	.109 ±.002	[2.78 ±0.05mm]	6 mm ²			
D	NOT		USED			
CRIMP	SIZE	TYPE	RANGE			
INSUL	.200	[5.08mm]	F	6 - 10 mm ²		
INSUL	.280	[7.11mm]	F	4.5 - 6.6 mm		
WIRE STRIP LENGTH	TERM APPL	SPEC	FEED	APPL INSTRUCTION	SET UP GAGE	LAYOUT
-	-	-	1.134	408-8039	458638-1	L1648

-1		LEADMAKER		MECH POST FEED			
-2		BENCH MODEL K		MECH PRE FEED			
-3		BENCH MODEL G		MECH PRE FEED			
REF	REF	REF	-	A			
REF	REF	REF	-	A	22594-8	NUT, HEX	70
REF	REF	REF	-	B	240628-1	PLATE, ADJ	69
REF	REF	REF	-	B	240626-1	SHAFT, PIVOT	68
REF	REF	REF	-	B	240633-1	BUSHING	67
REF	REF	REF	-	A	455680-1	LEVER, INTERMEDIATE	66
REF	REF	REF	-	B	240629-1	BLOCK, PIVOT	65
REF	REF	REF	-	A	240632-2	SCR, ADJ	64
REF	REF	REF	-	B	240659-3	PIN, CAM ROLLER	63
REF	REF	REF	-	B	240658-1	CAM, ROLLER	62
REF	REF	REF	-	B	454398-1	ROD, FEED	61
REF	REF	REF	-	C	454220-1	CAP, RAM	59
REF	REF	REF	-	D	453736-1	HOUSING	58
REF	REF	REF	-	B	240624-1	PIN, FEED FINGER	55
REF	REF	REF	-	B	691499-1	SPRING, FEED FINGER	54
REF	REF	REF	-	B	240635-1	FINGER, FEED	53
REF	REF	REF	-	B	240634-3	LEVER, TERMINAL	52
REF	REF	REF	-	C	454220-1	CAP, RAM	59
REF	REF	REF	-	D	453736-1	HOUSING	58
REF	REF	REF	-	B	690602-6	CAM, PRE-FEED 1 5/8 ST	49
REF	REF	REF	-	B	690602-5	CAM, PRE-FEED 1 1/8 ST	48
REF	REF	REF	-	B	690501-4	CAM, POST-FEED 1 5/8 ST	47
REF	REF	REF	-	A	690191-1	PLUG, NYLON	45
REF	REF	REF	-	C	455674-1	RAM	44
REF	REF	REF	-	A	690125-1	WASHER, LAMINATED	43
REF	REF	REF	-	A	690124-7	WASHER, RAM	42
REF	REF	REF	-	A	690686-2	BOLT, CRIMPER (5/16-24x1.00)	41
REF	REF	REF	-	A	23241-6	BALL, STEEL	40
REF	REF	REF	-	A	690170-1	SPRING, COMPRESSION	39
REF	REF	REF	-	C	690142-1	DISC, INSULATION	38
REF	REF	REF	-	D	354777-1	WIRE DISC, PLASTIC	37
REF	REF	REF	-	A	22480-5	WASHER, SPRING	36
REF	REF	REF	-	B	690212-1	POST, RAM	35
REF	REF	REF	-	D	458980-2	APPLICATOR, BASIC (SUB ASSY)	32
REF	REF	REF	-	A	4-690451-8	SPACER, STRIPPER	28
REF	REF	REF	-	A	690455-8	STRIPPER	27
REF	REF	REF	-	C	455676-1	PLATE, BASE	26
REF	REF	REF	-	A	22354-8	DRAG, STUD	25
REF	REF	REF	-	B	458803-5	PLATE, STRIP GUIDE	24
REF	REF	REF	-	C	240825-5	PLATE, STRIP HOLD DOWN	23
REF	REF	REF	-	A	4-22281-1	SPRING, DRAG	22
REF	REF	REF	-	A	454177-1	DRAG, STOCK	20
REF	REF	REF	-	C	1-454204-0	GUIDE, STRIP (FRONT)	18
REF	REF	REF	-	A	454178-1	GUIDE, FEED ROD	17
REF	REF	REF	-	A	4-22284-9	SPRING, FEED RETURN	16
REF	REF	REF	-	C	1-690481-0	SPACER, HOLD DOWN	13
REF	REF	REF	-	A	23846-1	SPRING, HOLD DOWN	12
REF	REF	REF	-	B	240833-3	PLATE, REAR SHEAR	11
REF	REF	REF	-	B	690482-5	PLATE, FRONT SHEAR	9
REF	REF	REF	-	D	9-683452-4	ANVIL	8
REF	REF	REF	-	B	690474-5	BLADE, SLUG	7
REF	REF	REF	-	D	1-455892-4	HOLD DOWN, TERMINAL	6
REF	REF	REF	-	C	5-240641-1	SPACER, SLUG BLADE	5
REF	REF	REF	-	B	238009-1	SPACER, BLOCK CRIMPER	4
REF	REF	REF	-	C	8-456134-1	CRIMPER, INSULATION	3
REF	REF	REF	-	B	2-455888-3	SPACER, CRIMPER	2
REF	REF	REF	-	C	3-458141-9	CRIMPER, WIRE	1

QTY	REQD	PER	ASSY	PART NO	DESCRIPTION	ITEM NO	
2	2	2	-	C	8-354778-9	PIN, WIRE DISC (.2940)C	129
2	2	2	-	C	7-354778-1	PIN, WIRE DISC (.2850)B	128
2	2	2	-	C	4-354778-1	PIN, WIRE DISC (.2700)A	126
1	1	1	-	A	986950-1	WASHER, FLAT PRECISION	125
REF	REF	REF	-	A	21045-3	RING, RET "C" (Ø.187)FD PIN	124
REF	REF	REF	-	A	5-21028-1	PIN, STD SPRING (Ø.12)FD ADJ ROD	123
REF	REF	REF	-	A	1-21030-7	PIN, DOWEL (Ø.187x1.50)HSG	120
REF	REF	REF	-	A	1-21030-1	PIN, DOWEL (Ø.187x.50)LEVER	119
REF	REF	REF	-	A	21899-4	WASHER, FLAT (Ø5/16)SCR ADJ	116
REF	REF	REF	-	A	21024-5	WASHER, LOCK (NO.10)FD ROD GDE	112
7	7	7	-	A	21024-4	WASHER, LOCK (NO.8)SHEAR BL	110
2	2	2	-	A	21018-4	NUT, HEX (4-40)DRAG	108
REF	REF	REF	-	A	21018-5	NUT, HEX (6-32)FD ADJ PL	107
2	2	2	-	A	21022-2	NUT, HEX SL (8-32)DRAG STUD	105
2	2	2	-	A	2-21006-6	SCR, SKT SET (4-40x.62)DRAG	102
1	1	1	-	A	21009-2	SCR, SKT SET (1/4-20x.25)RAM	101
2	2	2	-	A	21017-2	SCR, DRIVE (#2x.19) ID PLATE	100
1	1	1	-	A	1-21002-7	SCR, BHC (6-32x.38) CAM	99
1	1	1	-	B	461264-1	PLATE, IDENTIFICATION	98
REF	REF	REF	-	A	6-23715-5	SCR, PAN HD (6-32x1.50)FEED ADJ	97
2	2	2	-	A	2-21002-3	SCR, BHC (8-32x.62) STRIPPER	95
REF	REF	REF	-	A	2-21002-9	SCR, BHC (10-32x.75)HSG CAP	94
1	1	1	-	A	22733-8	SCR, BHC (8-32x.38 LW) ANVIL	93
4	4	4	-	A	3-21002-3	SCR, BHC (1/4-20x.50) ST 6D PL	92
REF	REF	REF	-	A	2-22733-8	SCR, BHC (1/4-20x.62)BASE PL	91
REF	REF	REF	-	A	2-21000-8	SCR, SHC (8-32x.62) SLUG BLADE	87
3	3	3	-	A	2-21000-6	SCR, SHC (8-32x.375) STRIP GUIDE	86
2	2	2	-	A	2-21000-9	SCR, SHC (8-32x.75)R STRIP GUIDE	85
REF	REF	REF	-	A	3-21000-7	SCR, SHC (10-32x.75)FEED ROD GDE	84
1	1	1	-	A	3-21000-6	SCR, SHC (10-32x.62)SHEAR PL	83
REF	REF	REF	-	A	3-21000-6	SCR, SHC (10-32x.62)FEED ADJ PL	82
REF	REF	REF	-	A	3-21000-4	SCR, SHC (10-32x.38)PIVOT BLOCK	81
1	1	1	-	A	3-21002-1	SCR, BHC (10-32x1.00)SHEAR PL	80
-	REF	-	-	A	455745-1	GUARD, WINDOW	79
1	1	1	-	A	690603-1	SPRING, ASSIST	74
1	1	1	-	A	23030-1	SCR, SKT CAP (6-32x.25)CP DSC	73
REF	REF	REF	-	A	458109-1	WASHER, FLAT (SPECIAL)	72
REF	REF	REF	-	A	690517-1	SPACER	71

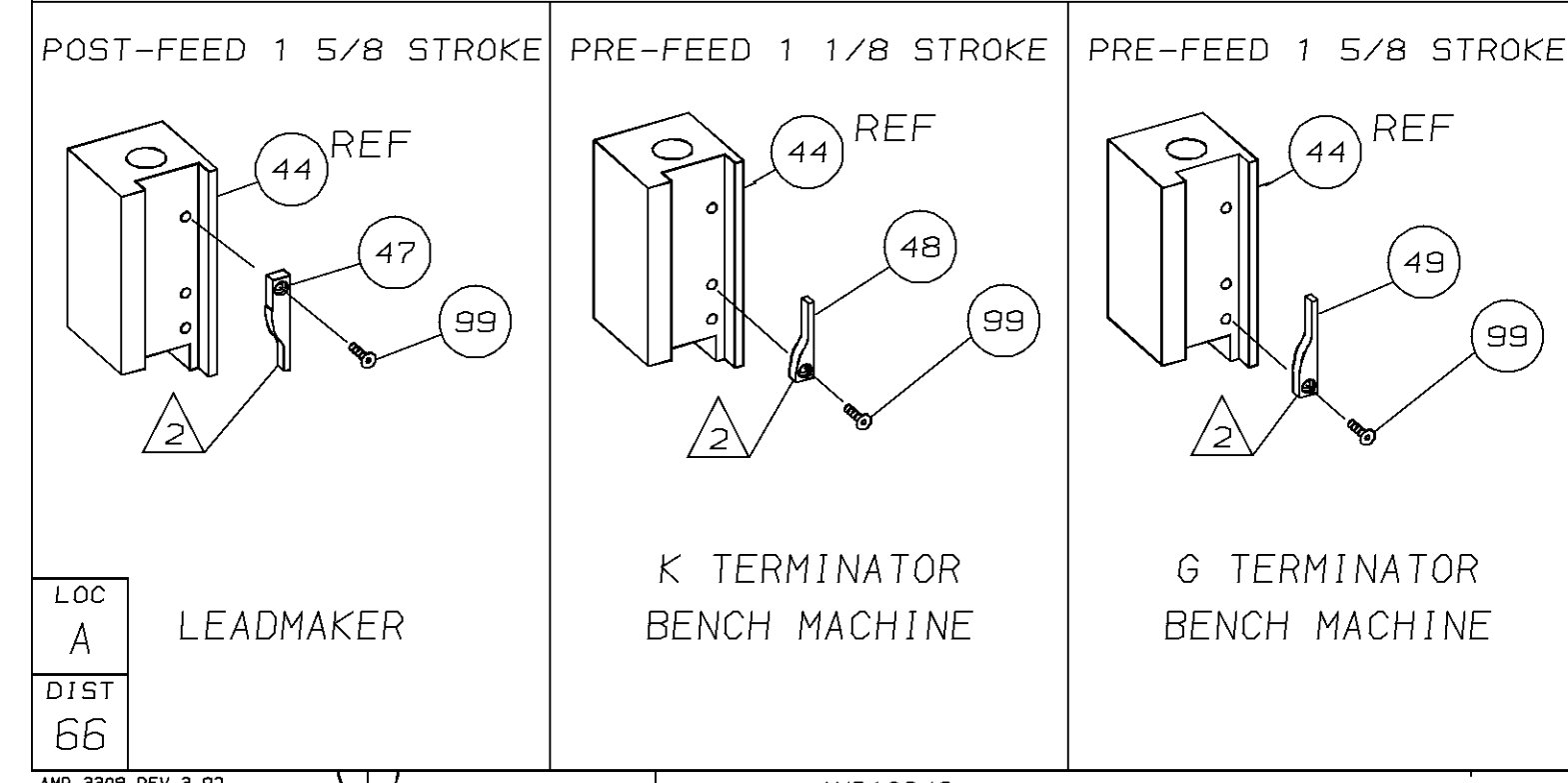

- 1 RECOMMENDED SPARE PARTS.
- 2 GREASE LIGHTLY.
- 3 GUARD MUST BE IN PLACE WHEN OPERATING APPLICATOR IN A BENCH MACHINE.
- 4 LUBRICATE DAILY USING NO. 20 MACHINE OIL.
- 5. ITEMS WITH QTY OF REF SPECIFIED (EXCEPT ITEMS 78 AND 79) ARE USED ON ITEM 32.

QTY REQD PER ASSY		PARTS LIST		REVISION OF EACH ASSY NO (WHEN BLANK, USE DWG REVISION)	
DR	J. BAKER	5/25/95	APP	5/31/95	A BEDDICK
CHK	C. ERISMAN	5/31/95	REL	7/28/95	B. MORGAN
3	PLC DEC	±			
4	PLC DEC	±			