

NHD-C12864CR-FSW-GBW

COG (Chip-On-Glass) Liquid Crystal Display Module

NHD- Newhaven Display
C12864- 128 x 64 pixels
CR- Model
F- Transflective
SW- Side White LED backlight
G- STN - Gray
B- 6:00 view
W- Wide Temperature
RoHS Compliant

Newhaven Display International, Inc.

2661 Galvin Court

Elgin IL, 60124

Ph: 847-844-8795

Fax: 847-844-8796

www.newhavendisplay.com

nhtech@newhavendisplay.com

nhsales@newhavendisplay.com

Document Revision History

Revision	Date	Description	Changed by
0	6/22/2011	Initial Release	-
1	11/26/2012	Backlight connector information updated	AK
2	4/23/2013	LCD backlight connector changed to A2001H-2P	AK
3	3/17/2015	Pin Description updated	RM

Functions and Features

- 128 x 64 pixels
- Built-in ST7565R controller
- Parallel/Serial mode
- +3.3V power supply
- 1/65 duty cycle; 1/9 bias
- RoHS Compliant

Mechanical Drawing

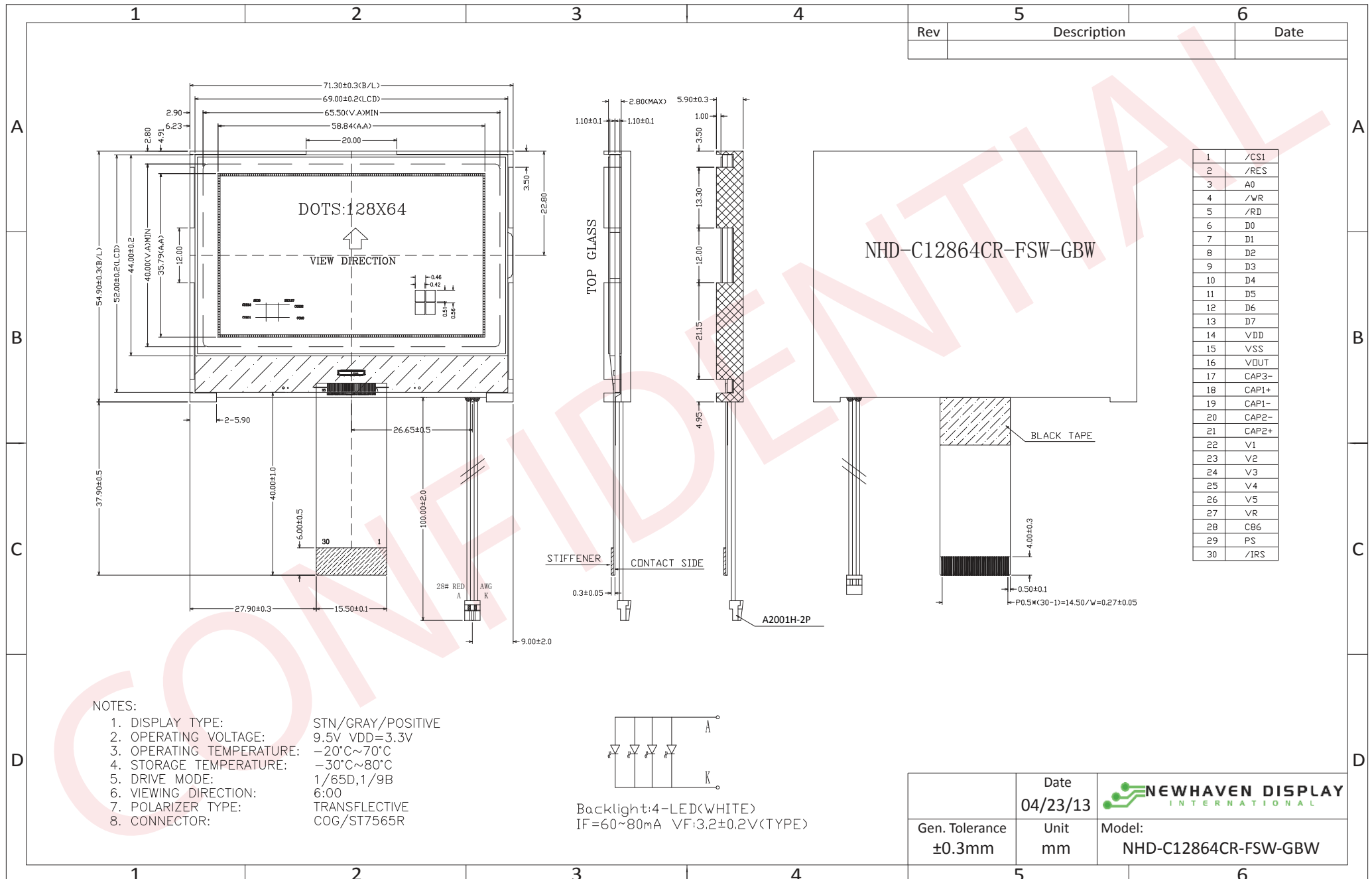

The drawing contained herein is the exclusive property of Newhaven Display International, Inc. and shall not be copied, reproduced, and/or disclosed in any format without permission.

Pin Description and Wiring Diagram

Pin No.	Symbol	External Connection	Function Description
1	/CS1	MPU	Active LOW chip select
2	/RES	MPU	Active LOW Reset signal
3	A0	MPU	Register select signal. 0: instruction; 1: data
4	R/W /WR	MPU	6800 Mode: Read/Write select signal. R/W=1: Read R/W:=0: Write 8080 Mode: Active LOW Write Signal
5	E /RD	MPU	6800 Mode: Active HIGH Enable Signal 8080 Mode: Active LOW Read Signal
6	D0	MPU	Parallel Interface DB0-DB7: Bi-directional 8-bit data bus Serial Interface: DB0-DB5: No connect DB6= Serial clock (SCL) DB7= Serial data input (SI)
7	D1		
8	D2		
9	D3		
10	D4		
11	D5		
12	D6/SCL		
13	D7/SI	MPU	
14	VDD	Power Supply	Power supply for LCD and logic (+3.3V)
15	VSS	Power Supply	Ground
16	VOUT	Power Supply	Connect to 1uF cap to VSS
17	CAP3+	Power Supply	Connect to 1uF cap to CAP1- (PIN-18)
18	CAP1-	Power Supply	Connect to 1uF cap to CAP3+(PIN17) and CAP1+(PIN19)
19	CAP1+	Power Supply	Connect to 1uF cap to CAP1- (PIN-18)
20	CAP2-	Power Supply	Connect to 1uF cap to CAP2+ (PIN-21)
21	CAP2+	Power Supply	Connect to 1uF cap to CAP2- (PIN-20)
22-26	V1-V5	Power Supply	1.0uF-2.2uF cap to VSS
27	VR	-	No Connect
28	C86	MPU	Select MPU interface pin. C86=H: 6800; C86=L: 8080
29	PS	MPU	Parallel/Serial select. PS= H: Parallel; PS=L: Serial
30	/IRS	MPU	Set HIGH to use internal resistors for V0 voltage level adjustment

Recommended LCD connector: 0.5mm Pitch, 30 pin FFC. Molex p/n: 52892-3095

Backlight connector: A2001H-2P **Mates with:** A2001WR-2P, A2001WR-S-2P, A2001WV-2P, A2001WV-S-2P

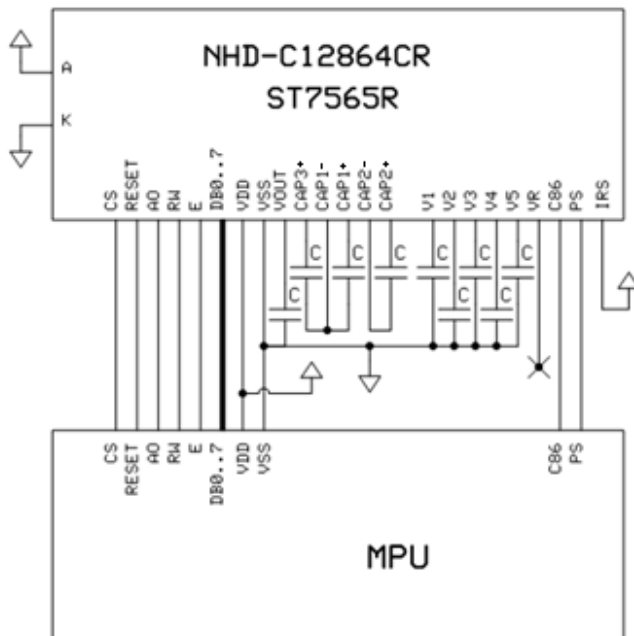

Electrical Characteristics

Item	Symbol	Condition	Min.	Typ.	Max.	Unit
Operating Temperature Range	TOP	Absolute Max	-20	-	+70	°C
Storage Temperature Range	TST	Absolute Max	-30	-	+80	°C
Supply Voltage	VDD		2.7	3.0	3.3	V
Supply Current	IDD	Ta=25°C, VDD=3.0V	-	-	0.5	mA
Supply for LCD (contrast)	VDD-V0	Ta=25°C	-	9.5	-	V
"H" Level input	Vih		0.8*VDD	-	VDD	V
"L" Level input	Vil		VSS	-	0.2*VDD	V
"H" Level output	Voh		0.8*VDD	-	VDD	V
"L" Level output	Vol		VSS	-	0.2*VDD	V
Backlight Supply Voltage	VLED		-	3.2	-	V
Backlight Supply Current	ILED	VLED=3.0V	-	60	80	mA

Optical Characteristics

Item	Symbol	Condition	Min.	Typ.	Max.	Unit
Viewing Angle - Top		CR≥2	-	35	-	°
Viewing Angle - Bottom			-	60	-	°
Viewing Angle - Left			-	40	-	°
Viewing Angle - Right			-	40	-	°
Contrast Ratio	CR		-	6	-	-
Response Time (rise)	Tr		-	150	250	ms
Response Time (fall)	Tf		-	150	250	ms

Controller Information

Built-in ST7565R controller.

Please download specification at http://www.newhavendisplay.com/app_notes/ST7565R.pdf

Table of Commands

Command	Command Code									Function			
	A0	/RD	/WR	D7	D6	D5	D4	D3	D2		D1	D0	
(1) Display ON/OFF	0	1	0	1	0	1	0	1	1	1	0	1	LCD display ON/OFF 0: OFF, 1: ON
(2) Display start line set	0	1	0	0	1	Display start address					0	Sets the display RAM display start line address	
(3) Page address set	0	1	0	1	0	1	Page address					0	Sets the display RAM page address
(4) Column address set upper bit	0	1	0	0	0	0	1	Most significant column address				0	Sets the most significant 4 bits of the display RAM column address.
Column address set lower bit				0	0	0	0	Least significant column address				0	Sets the least significant 4 bits of the display RAM column address.
(5) Status read	0	0	1	Status				0	0	0	0	0	Reads the status data
(6) Display data write	1	1	0	Write data							0	Writes to the display RAM	
(7) Display data read	1	0	1	Read data							0	Reads from the display RAM	
(8) ADC select	0	1	0	1	0	1	0	0	0	0	0	1	Sets the display RAM address SEG output correspondence 0: normal, 1: reverse
(9) Display normal/reverse	0	1	0	1	0	1	0	0	1	1	0	1	Sets the LCD display normal/ reverse 0: normal, 1: reverse
(10) Display all points ON/OFF	0	1	0	1	0	1	0	0	1	0	0	1	Display all points 0: normal display 1: all points ON
(11) LCD bias set	0	1	0	1	0	1	0	0	0	1	0	1	Sets the LCD drive voltage bias ratio 0: 1/9 bias, 1: 1/7 bias (ST7565R)
(12) Read-modify-write	0	1	0	1	1	1	0	0	0	0	0	0	Column address increment At write: +1 At read: 0
(13) End	0	1	0	1	1	1	0	1	1	1	0	0	Clear read/modify/write
(14) Reset	0	1	0	1	1	1	0	0	0	0	1	0	Internal reset
(15) Common output mode select	0	1	0	1	1	0	0	0	*	*	*	*	Select COM output scan direction 0: normal direction 1: reverse direction
(16) Power control set	0	1	0	0	0	1	0	1	Operating mode			0	Select internal power supply operating mode
(17) V ₀ voltage regulator internal resistor ratio set	0	1	0	0	0	1	0	0	Resistor ratio			0	Select internal resistor ratio(Rb/Ra) mode
(18) Electronic volume mode set	0	1	0	1	0	0	0	0	0	0	0	1	Set the V ₀ output voltage electronic volume register
Electronic volume register set				0	0	Electronic volume value					0		
(19) Sleep mode set	0	1	0	1	0	1	0	1	1	0	0	1	0: Sleep mode, 1: Normal mode
(20) Booster ratio set	0	1	0	1	1	1	1	1	0	0	0	0	select booster ratio 00: 2x,3x,4x 01: 5x 11: 6x
(21) NOP	0	1	0	1	1	1	0	0	0	0	1	1	Command for non-operation
(22) Test	0	1	0	1	1	1	1	*	*	*	*	*	Command for IC test. Do not use this command

Timing Characteristics

System Bus Read/Write Characteristics 1 (For the 8080 Series MPU)

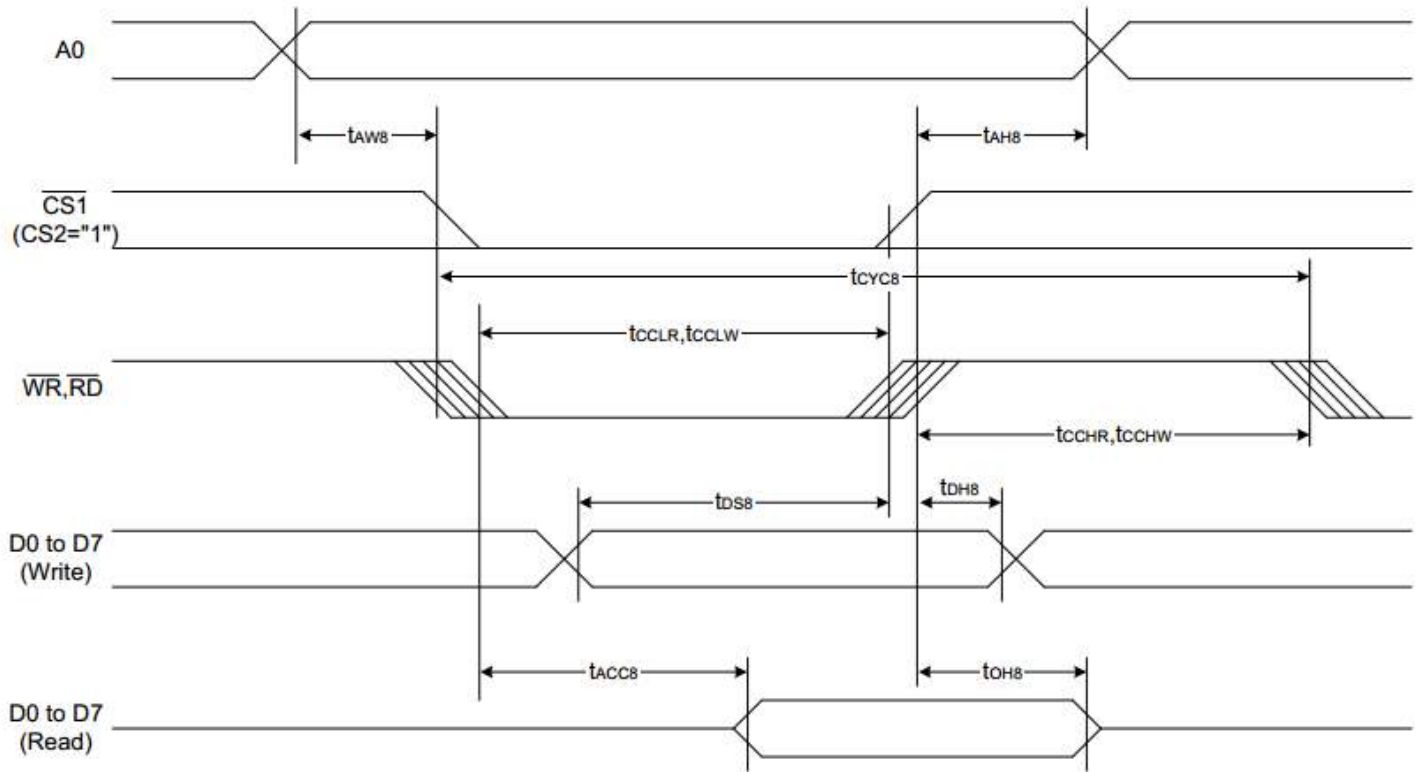

Item	Signal	Symbol	Condition	Rating		Units
				Min.	Max.	
Address hold time	A0	t_{AH8}		0	—	Ns
Address setup time		t_{AW8}		0	—	
System cycle time		t_{CYC8}		240	—	
Enable L pulse width (WRITE)	WR	t_{CCLW}		80	—	
Enable H pulse width (WRITE)		t_{CCHR}		80	—	
Enable L pulse width (READ)	RD	t_{CCLR}		140	—	
Enable H pulse width (READ)		t_{CCHR}		80	—	
WRITE Data setup time	D0 to D7	t_{DSS}		40	—	
WRITE Address hold time		t_{DHS}		0	—	
READ access time		t_{ACC8}	$C_L = 100 \text{ pF}$	—	70	
READ Output disable time		t_{OHS}	$C_L = 100 \text{ pF}$	5	50	

System Bus Read/Write Characteristics 2 (For the 6800 Series MPU)

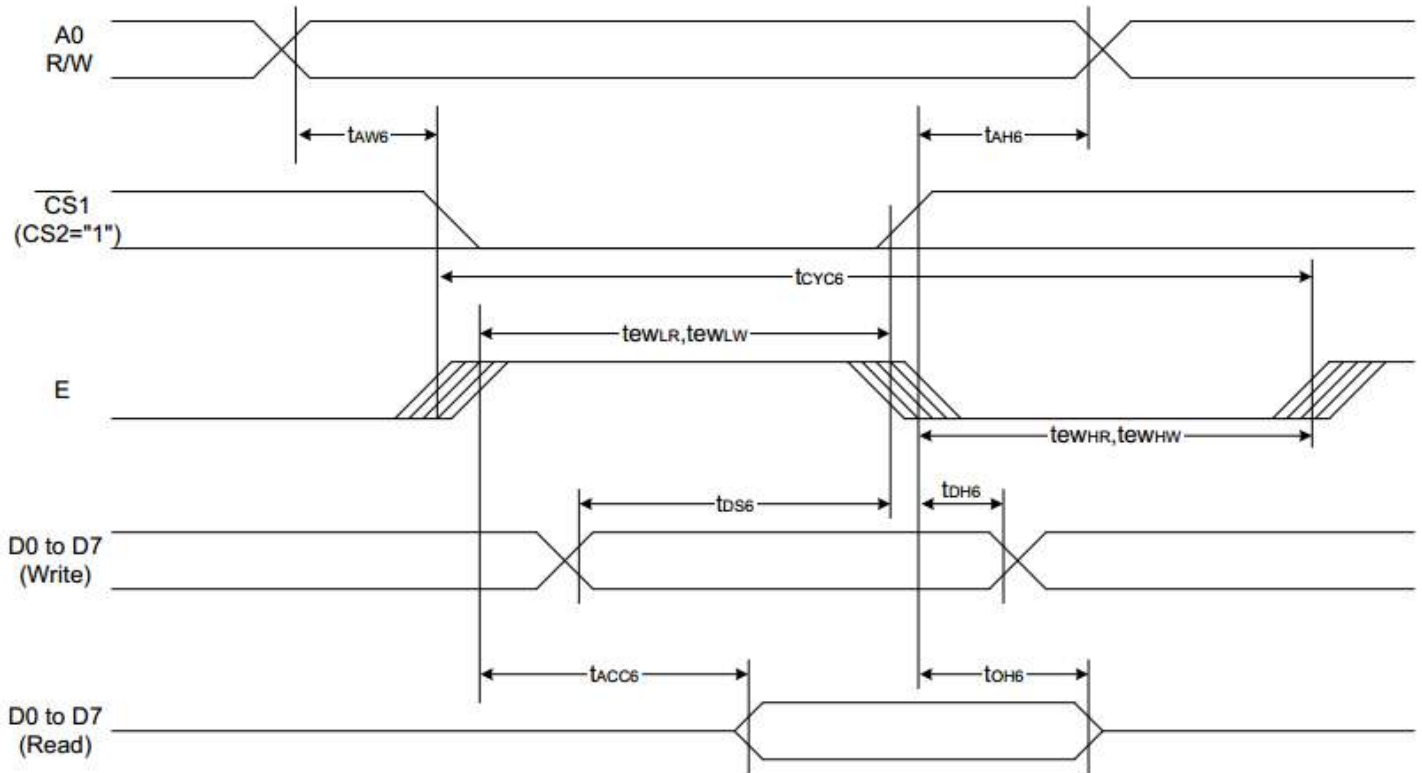

Item	Signal	Symbol	Condition	Rating		Units
				Min.	Max.	
Address hold time	A0	t_{AH6}		0	—	ns
Address setup time		t_{AW6}		0	—	
System cycle time		t_{CYC6}		240	—	
Enable L pulse width (WRITE)	WR	t_{EWLW}		80	—	
Enable H pulse width (WRITE)		t_{EWHW}		80	—	
Enable L pulse width (READ)	RD	t_{EWLR}		80	—	
Enable H pulse width (READ)		t_{EWHR}		140	—	
WRITE Data setup time	D0 to D7	t_{DSE}		40	—	
WRITE Address hold time		t_{DH6}		0	—	
READ access time		t_{ACC6}	$C_L = 100 \text{ pF}$	—	70	
READ Output disable time		t_{OH6}	$C_L = 100 \text{ pF}$	5	50	

The 4-line SPI Interface

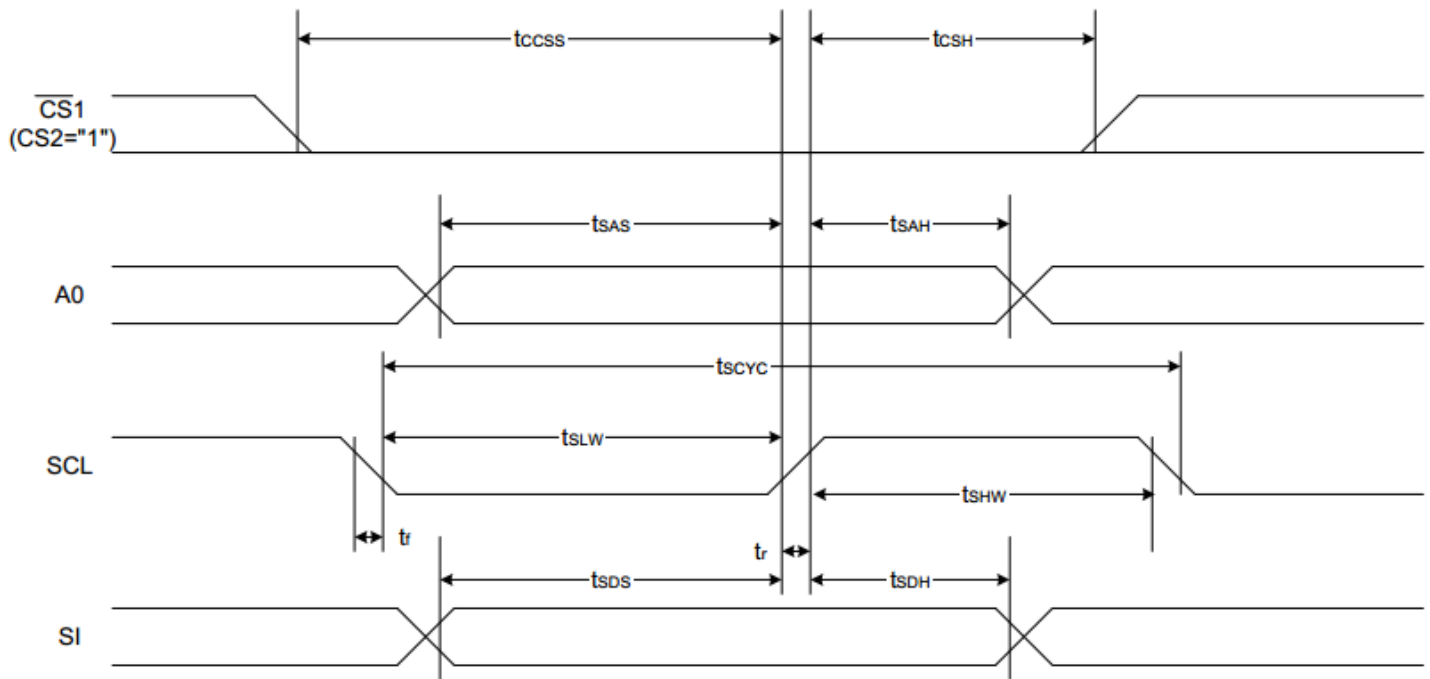

Item	Signal	Symbol	Condition	Rating		Units
				Min.	Max.	
4-line SPI Clock Period	SCL	T_{scyc}		50	—	ns
SCL "H" pulse width		T_{shw}		25	—	
SCL "L" pulse width		T_{SLW}		25	—	
Address setup time	A0	T_{SAS}		20	—	
Address hold time		T_{SAH}		10	—	
Data setup time	SI	T_{sds}		20	—	
Data hold time		T_{SDH}		10	—	
CS-SCL time	CS	T_{css}		20	—	
CS-SCL time		T_{csh}		40	—	

Example Initialization Program

```
.....  
  
Sub Init  
Set P3.0  
Set P3.1  
Reset P3.4  
Set P3.3          'reset  
Reset P3.3  
Waitms 2  
Set P3.3  
Waitms 20  
A = &HA2          '1/9 BIAS  
Call Writecom  
A = &HA0          'ADC SELECT , NORMAL  
Call Writecom  
A = &HC8          'COM OUTPUT REVERSE  
Call Writecom  
A = &HA4          'DISPLAY ALL POINTS NORMAL  
Call Writecom  
A = &H40          'DISPLAY START LINE SET  
Call Writecom  
A = &H25          'INTERNAL RESISTOR RATIO  
Call Writecom  
A = &H81          'ELECTRONIC VOLUME MODE SET  
Call Writecom  
A = &H13          'ELECTRONIC VOLUME  
Call Writecom  
A = &H2F          'POWER CONTROLLER SET  
Call Writecom  
A = &HAF          'DISPLAY ON  
Call Writecom  
End Sub
```

```
.....  
  
Sub Writecom  
Reset P3.2        'A0  
Reset P3.1        'R/W  
Reset P3.4        'CS1  
Set P3.0          'E  
P1 = A  
Reset P3.0  
Set P3.4  
End Sub
```

```
.....  
  
Sub Writedata  
Set P3.2  
Reset P3.1  
Reset P3.4  
Set P3.0  
P1 = A  
Reset P3.0  
Set P3.4  
End Sub
```

Quality Information

Test Item	Content of Test	Test Condition	Note
High Temperature storage	Endurance test applying the high storage temperature for a long time.	+80°C , 48hrs	2
Low Temperature storage	Endurance test applying the low storage temperature for a long time.	-30°C , 48hrs	1,2
High Temperature Operation	Endurance test applying the electric stress (voltage & current) and the high thermal stress for a long time.	+70°C 48hrs	2
Low Temperature Operation	Endurance test applying the electric stress (voltage & current) and the low thermal stress for a long time.	-20°C , 48hrs	1,2
High Temperature / Humidity Operation	Endurance test applying the electric stress (voltage & current) and the high thermal with high humidity stress for a long time.	+40°C , 90% RH , 48hrs	1,2
Thermal Shock resistance	Endurance test applying the electric stress (voltage & current) during a cycle of low and high thermal stress.	-0°C,30min -> 25°C,5min -> 50°C,30min = 1 cycle 10 cycles	
Vibration test	Endurance test applying vibration to simulate transportation and use.	10-55Hz , 15mm amplitude. 60 sec in each of 3 directions X,Y,Z For 15 minutes	3
Static electricity test	Endurance test applying electric static discharge.	VS=800V, RS=1.5kΩ, CS=100pF One time	

Note 1: No condensation to be observed.

Note 2: Conducted after 4 hours of storage at 25°C, 0%RH.

Note 3: Test performed on product itself, not inside a container.

Precautions for using LCDs/LCMs

See Precautions at www.newhavendisplay.com/specs/precautions.pdf

Warranty Information and Terms & Conditions

http://www.newhavendisplay.com/index.php?main_page=terms