

DATE	REV	ECN	APP'D BY
2/4/2021	A0		JE
4/23/2021	A1	11739	GL

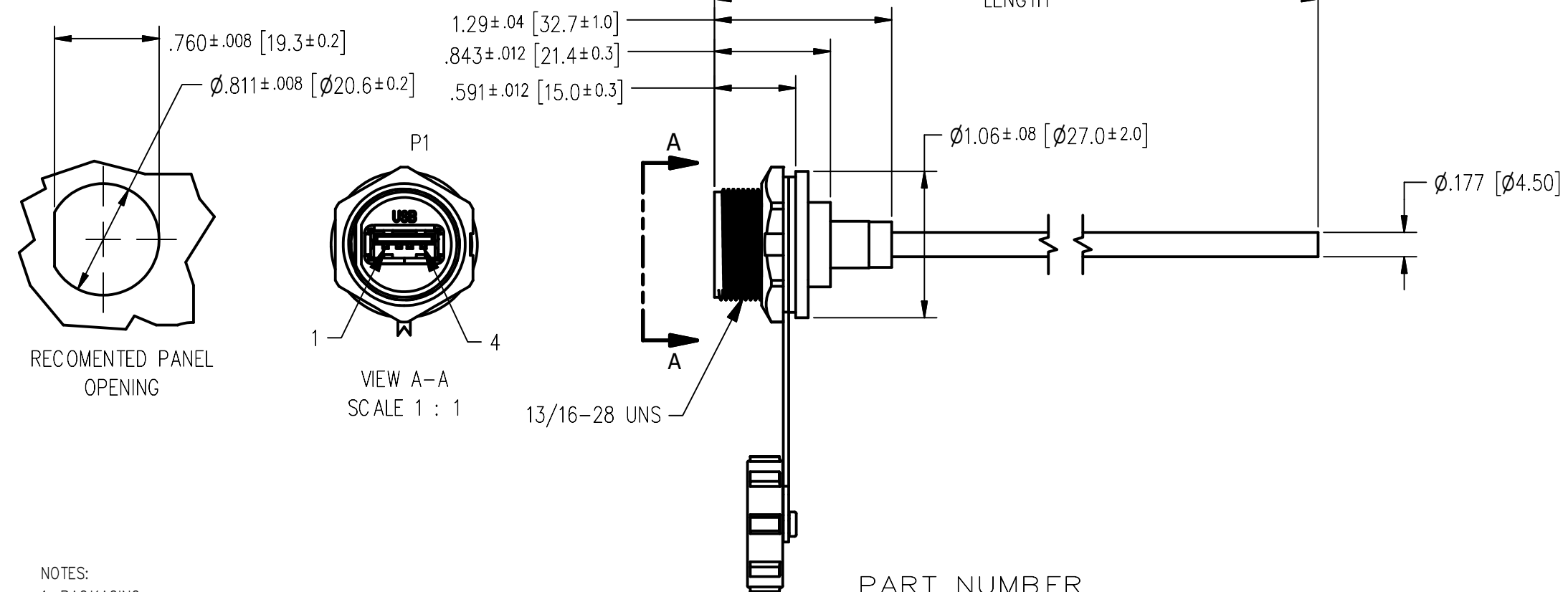

NOTES:

1. PACKAGING:
  - a. EACH CABLE ASSEMBLY TO BE INDIVIDUALLY BAGGED
2. MATERIAL:
  - a. CABLE: USB 2.0 A/F UL2725 1P\*28AWG (7/0.2TC) +AL+D+B64 PVC COVER, COLOR BLACK.
  - b. USB 2.0 A/F
    - INSULATOR: PPT UL 94V-0, COLOR WHITE
    - METAL SHELL: COPPER ALLOY, NI PLATING
    - CONTACTS: COPPER ALLOY Au FLASH ON CONTACT AREA OVER NI
  - c. OVERMOLD: PVC UL 94V-0 COLOR BLACK
  - d. HOUSING: PA66 UL94V-0 COLOR BLACK
  - e. GASKET: SILICONE, COLOR BLACK
  - f. SCREW NUT: PA66 UL94V-0 COLOR BLACK
  - g. DUST CAP: PA66 UL94V-0 COLOR BLACK
  - h. DUST CAP GASKET: SILICONE
  - g. DUST CAP: PA66 UL94V-0 COLOR BLACK
  - h. DUST CAP GASKET: SILICONE
3. SPECIFICATIONS:
  - a. WIRE SPEIFICATION 23/24 AWG
  - b. NUMBER OF CONTACTS: 4
  - c. TEMPERATURE RANGE -40~C~ 80~C
  - d. FLAMMABILYY RATING: UL94-V0
  - e. PROTECTION LEVEL: IP67
  - f. WITHSTANDING VOLTAGE: 1000V/1 MIN
  - g. CURRENT RATING: 1.5A
  - h. CONTACT RESISTANCE: ≤ 30MΩ
  - ii. NSULATION RESISTANCE: 100MΩ DC500V

PART NUMBER  
STRUCTURE

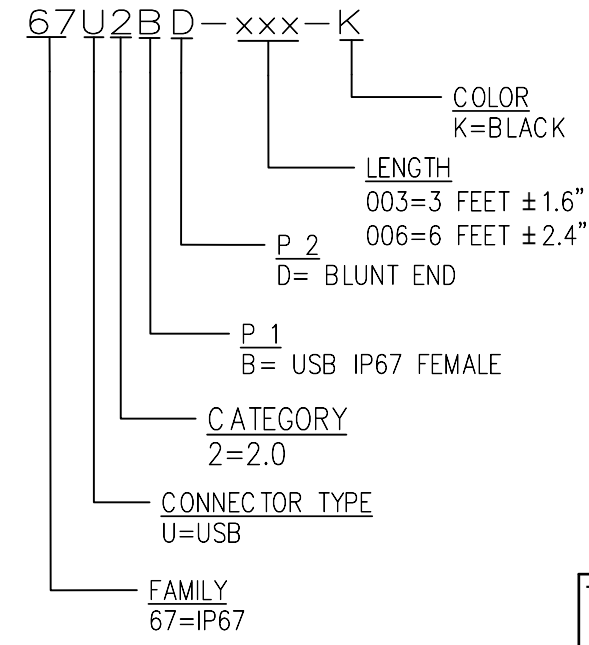

P1	WIRE COLOR	P2
1	RED	
2	WHITE	
3	GREEN	
4	BLACK	
SHELL	SHIELD BRAID	

<p>THIRD ANGLE PROJECTION</p>	<p>11118 Susquehanna Trail South Glen Rock, PA 17327-9199 (717) 235-7512 <a href="http://www.stewartconnector.com">http://www.stewartconnector.com</a></p>						
<p>DO NOT SCALE DRAWING DRAWING IS SUBJECT TO CHANGE WITHOUT NOTICE</p>	<p>TITLE: <b>USB 2.0 TYPE A FEMALE CIRCULAR COUPLING TO BLUNT</b></p>						
<p>DIMENSIONS: INCHES [METRIC]</p> <p>UNLESS OTHERWISE SPECIFIED TOLERANCES ARE ±.005 [0.13] ANGLES ARE ± 1°</p>	<p>THIS DRAWING AND THE SUBJECT MATTER SHOWN THEREON ARE CONFIDENTIAL AND THE PROPRIETARY PROPERTY OF STEWART CONNECTOR AND SHALL NOT BE REPRODUCED, COPIED, OR USED IN ANY MANNER WITHOUT PRIOR WRITTEN CONSENT OF STEWART CONNECTOR. THIS PRODUCT MAY BE PROTECTED BY ONE OR MORE OF THE FOLLOWING US PATENTS: 5791942 6217391 6368159 6419526 6602097 687722 6964587 7048590 7086909 7568950 7686650 OTHER PATENTS MAY BE PENDING.</p>						
<p>SHEET NO. <b>1 OF 1</b></p>	<table border="1"> <tr> <td>DRN BY: <b>GWL</b></td> <td>DATE: <b>1/14/2021</b></td> </tr> <tr> <td>APPD BY: <b>JE</b></td> <td>DATE: <b>2/4/2021</b></td> </tr> <tr> <td>DWG NO: <b>CT999239</b></td> <td>REV. <b>A1</b></td> </tr> </table>	DRN BY: <b>GWL</b>	DATE: <b>1/14/2021</b>	APPD BY: <b>JE</b>	DATE: <b>2/4/2021</b>	DWG NO: <b>CT999239</b>	REV. <b>A1</b>
DRN BY: <b>GWL</b>	DATE: <b>1/14/2021</b>						
APPD BY: <b>JE</b>	DATE: <b>2/4/2021</b>						
DWG NO: <b>CT999239</b>	REV. <b>A1</b>						

