

PRODUCT NUMBER
SEE TABLE

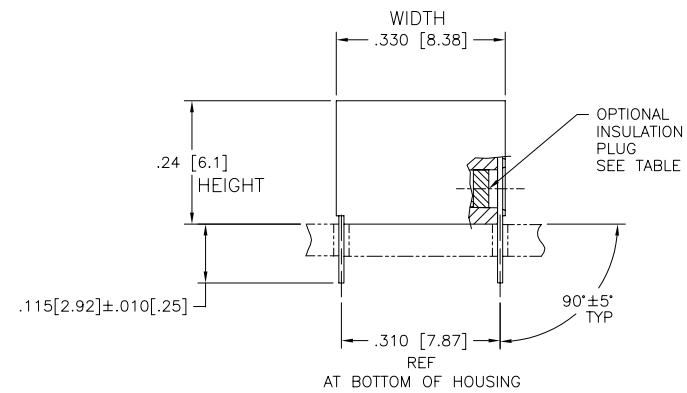
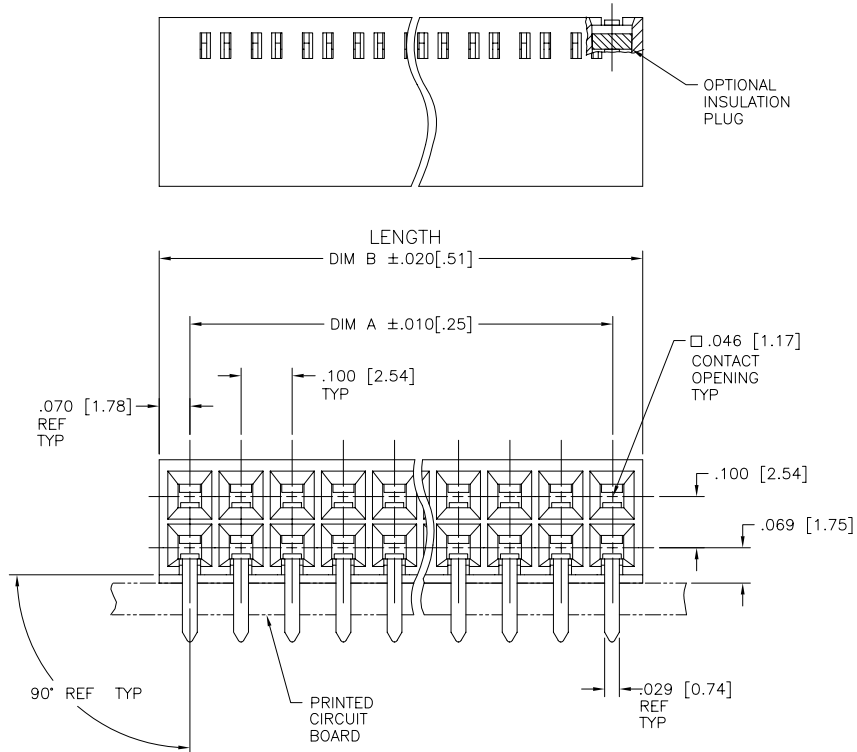

Copyright FCI

mat'l. code				surface ISO 1302 ✓		tolerance ISO 406 ISO 1101		projection INCH/MM		product family CARD CONN.	
tolerances unless otherwise specified				angles		linear		scale 1:1		title	
ltr	ecn	no	dr	date						BERGCON HORIZ. CARD CONN	
AR	V32114	MSC	6/8/94							DOUBLE ROW .100/2.54 cc	
AS	V41413	MRC	9/30/94							dwg no	
AT	V61611	MDF	10/29/96	0'±2'						sheet 1 of 11 size	
AU	V70992	JM	10/12/97	dr	M.CLOUSER	6/7/94				65000 A3	
AV	V02523	AZ	10/20/00	enr	H.SUNDY	6/7/94				type Product Customer Drawing	
AW	M05-0181	ERE	09/05/05	chr	H.SUNDY	6/7/94					
AX	M06-0319	MHT	8/21/06	appd	H.SUNDY	6/7/94					
sheet	revision	AX	AX	AX	AX	AX	AX	AX	AX	AX	AX
index	sheet	1	2	3	4	5	6	7	8	9	10

form: A3

PRODUCT NUMBER
SEE TABLE

NOTES:

1. HOUSING MATERIAL: (SEE TABLE)
FILLED HIGH TEMPERATURE NYLON, COLOR BLACK
2. TERMINAL MATERIAL:
BODY-BRASS, .010/.25 THICK
SPRING- Be-Cu, HEAT TREATED
BODY PLATING- SEE TABLE FOR Au PLATING THICKNESS
OVER 50u"/1.27u Ni IN CONTACT AREA.
SPRING PLATING:- Au FLASH
LEAD FREE BODY PLATING: 2.54u/100u" Sn
3. MARKING: "FCJ" PART NUMBER AND DATE CODE
LEGIBLE ON TUBE LABEL.
4. APPLICATION INFORMATION:
A. RECOMMENDED MOUNTING HOLE PATTERN IS SHOWN
IN FIGURE 1.
B. ALL MATING PINS TO BE .025/.64 SQ. ON TRUE
CENTER OF GIVEN TERMINAL SPACINGS WITHIN
.015/.38 DIA.
C. SUGGESTED MATING PIN LENGTH .350[8.89]±.020[.51].
5. ADD "LF" SUFFIX AT THE END OF PART NUMBER
FOR LEAD FREE OPTION.
6. THESE PRODUCTS MEET EUROPEAN UNION DIRECTIVES
AND OTHER COUNTRY REGULATIONS AS DESCRIBED IN
GS-22-008.
7. THIS PART WILL WITHSTAND EXPOSURE TO 260°C PEAK
TEMPERATURE FOR 20 SECONDS IN A WAVE SOLDER,
INFRA-RED OR VAPOR PHASE
SOLDER PROCESS.
8. "THIS PRODUCT HAS 100% TIN PLATING IN THE INTERFACE
AND HAS NOT BEEN TESTED FOR WHISKER GROWTH IN ALL
INTERCONNECT ENVIRONMENTS."

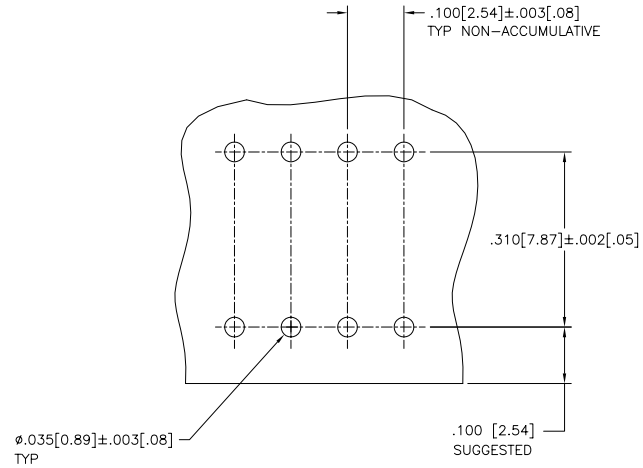

FIGURE 1
SCALE 10/1

FCJ
FCJconnect.com

Copyright FCJ

mat'l. code		surface ISO 1302 ✓		tolerance ISO 406 ISO 1101		projection ⊕		product family CARD CONN.	
ltr	ecn	no	dr	date		tolerances unless otherwise specified		title	
AX						angles	linear	BERGCON HORIZ. CARD CONN	
						0'±2'	.xx±.01/.3 .xxx±.005/.13 .xxxx±.0020/.051	DOUBLE ROW .100/2.54 cc	
			dr	M.CLOUSER 6/7/94		scale 1:1		dwg no sheet2 of11size	
			enr	H.SUNDY 6/7/94		FCJ		65000 A3	
			chr	H.SUNDY 6/7/94				type Product Customer Drawing	
			appd	H.SUNDY 6/7/94					
sheet index	revision sheet								

PRODUCT NUMBER	HOUSING MATERIAL	NO. OF POS	DIM A	DIM B	SPRING THICKNESS	BODY PLATING THICKNESS	SPECIAL MARKINGS AND MISCELLANEOUS	CUSTOMER RESTRICTED	LEAD FREE OPTION
65000-001	HT NYLON	2X8	.700/17.78	.840/21.34	.0035/.089	40u"/1.02u Au			NOTE 5, 6
-002		2X8	.700/17.78	.840/21.34					
-003		2X9	.800/20.32	.940/23.88					
-004		2X9	.800/20.32	.940/23.88					
-005		2X10	.900/22.86	1.040/26.42					
-006		2X10	.900/22.86	1.040/26.42					
-007		2X11	1.000/25.40	1.140/28.96					
-008		2X11	1.000/25.40	1.140/28.96					
-009		2X12	1.100/27.94	1.240/31.50					
-010		2X12	1.100/27.94	1.240/31.50					
-011		2X13	1.200/30.48	1.340/34.04					
-012		2X13	1.200/30.48	1.340/34.04					
-013		2X14	1.300/33.02	1.440/36.58					
-014		2X14	1.300/33.02	1.440/36.58					
-015		2X15	1.400/35.56	1.540/39.12					
-016		2X15	1.400/35.56	1.540/39.12					
-017		2X16	1.500/38.10	1.640/41.66					
-018		2X16	1.500/38.10	1.640/41.66					
-019		2X17	1.600/40.64	1.740/44.20					
-020		2X17	1.600/40.64	1.740/44.20					
-021		2X18	1.700/43.18	1.840/46.74					
-022		2X18	1.700/43.18	1.840/46.74					
-023		2X19	1.800/45.72	1.940/49.28					
-024		2X19	1.800/45.72	1.940/49.28					
-025		2X20	1.900/48.26	2.040/51.82					
-026		2X20	1.900/48.26	2.040/51.82					
-027		2X21	2.000/50.80	2.140/54.36					
-028		2X21	2.000/50.80	2.140/54.36					
-029		2X22	2.100/53.34	2.240/56.90					
-030		2X22	2.100/53.34	2.240/56.90					
-031		2X23	2.200/55.68	2.340/59.44					
-032		2X23	2.200/55.68	2.340/59.44					
-033		2X24	2.300/58.42	2.440/61.98					
-034		2X24	2.300/58.42	2.440/61.98					
-035		2X25	2.400/60.96	2.540/64.52					
65000-036	HT NYLON	2X25	2.400/60.96	2.540/64.52	.0035/.089	40u"/1.02u Au			NOTE 5, 6



Copyright FCI

mat'l. code		surface ISO 1302 <input checked="" type="checkbox"/>	tolerance ISO 406 ISO 1101	projection 	product family CARD CONN.
ltr	ecn no	dr	date	tolerances unless otherwise specified	title
AX				angles linear .xx±.01/.3 .xxx±.005/.13 .xxxx±.0020/.051	BERGCON HORIZ. CARD CONN DOUBLE ROW .100/2.54 cc
				0'±2'	scale 1:1
		dr	M.CLOUSER	6/7/94	dwg no sheet 3 of 11 size
		enr	H.SUNDY	6/7/94	65000 A3
		chr	H.SUNDY	6/7/94	type Product Customer Drawing
		appd	H.SUNDY	6/7/94	
sheet index	revision sheet				

PRODUCT NUMBER	HOUSING MATERIAL	NO. OF POS	DIM A	DIM B	SPRING THICKNESS	BODY PLATING THICKNESS	SPECIAL MARKINGS AND MISCELLANEOUS	CUSTOMER RESTRICTED	LEAD FREE OPTION
65000-037	HT NYLON	2X 26	2.500/63.50	2.640/67.06	.0035/.089	40u"/1.02u Au			NOTE 5, 6
-038		2X 26	2.500/63.50	2.640/67.06					
-039		2X 27	2.600/66.04	2.740/69.60					
-040		2X 27	2.600/66.04	2.740/69.60					
-041		2X 28	2.700/68.58	2.840/72.14					
-042		2X 28	2.700/68.58	2.840/72.14					
-043		2X 29	2.800/71.12	2.940/74.68					
-044		2X 29	2.800/71.12	2.940/74.68					
-045		2X 30	2.900/73.66	3.040/77.22					
-046		2X 30	2.900/73.66	3.040/77.22					
-047		2X 31	3.000/76.20	3.140/79.76					
-048		2X 31	3.000/76.20	3.140/79.76					
-049		2X 32	3.100/78.74	3.240/82.30					
-050		2X 32	3.100/78.74	3.240/82.30					
-051		2X 33	3.200/81.28	3.340/84.84					
-052		2X 33	3.200/81.28	3.340/84.84					
-053		2X 34	3.300/83.82	3.440/87.38					
-054		2X 34	3.300/83.82	3.440/87.38					
-055		2X 35	3.400/86.36	3.540/89.92					
-056		2X 35	3.400/86.36	3.540/89.92					
-057		2X 36	3.500/88.90	3.640/92.46					
-058		2X 36	3.500/88.90	3.640/92.46					
-059		2X 37	3.600/91.44	3.740/95.00					
-060		2X 37	3.600/91.44	3.740/95.00					
-061		2X 38	3.700/93.98	3.840/97.54					
-062		2X 38	3.700/93.98	3.840/97.54					
-063		2X 39	3.800/96.52	3.940/100.08					
-064		2X 39	3.800/96.52	3.940/100.08					
-065		2X 40	3.900/99.06	4.040/102.62					
-066		2X 40	3.900/99.06	4.040/102.62					
-067		2X 41	4.000/101.60	4.140/105.16					
-068		2X 41	4.000/101.60	4.140/105.16					
-069		2X 42	4.100/104.14	4.240/107.70					
-070		2X 42	4.100/104.14	4.240/107.70					
-071		2X 43	4.200/106.68	4.340/110.24					
65000-072	HT NYLON	2X 43	4.200/106.68	4.340/110.24	.0035/.089	40u"/1.02u Au			NOTE 5, 6



FCIconnect.com

Copyright FCI

mat'l. code		surface ISO 1302 <input checked="" type="checkbox"/>		tolerance ISO 406 ISO 1101		projection 		product family CARD CONN.	
ltr		ecn no		dr		date		title	
AX								BERGCON HORIZ. CARD CONN DOUBLE ROW .100/2.54 cc	
								dwg no 65000	
								sheet 4 of 11 size A3	
								type Product Customer Drawing	
sheet index		revision sheet							

PRODUCT NUMBER	HOUSING MATERIAL	NO. OF POS	DIM A	DIM B	SPRING THICKNESS	BODY PLATING THICKNESS	SPECIAL MARKINGS AND MISCELLANEOUS	CUSTOMER RESTRICTED	LEAD FREE OPTION
65000-073	HT NYLON	2X44	4.300/109.22	4.440/112.78	.0035/.089	40u"/1.02u Au			NOTE 5, 6
-074		2X44	4.300/109.22	4.440/112.78					
-075		2X45	4.400/111.76	4.540/115.31					
-076		2X45	4.400/111.76	4.540/115.31					
-077		2X46	4.500/114.30	4.640/117.86					
-078		2X46	4.500/114.30	4.640/117.86					
-079		2X47	4.600/116.84	4.740/120.40					
-080		2X47	4.600/116.84	4.740/120.40					
-081		2X48	4.700/119.38	4.840/122.94					
-082		2X48	4.700/119.38	4.840/122.94					
-083		2X49	4.800/121.92	4.940/125.48					
-084		2X49	4.800/121.92	4.940/125.48					
-085		2X50	4.900/124.46	5.040/128.02					
-086		2X50	4.900/124.46	5.040/128.02					
-087		2X51	5.000/127.00	5.140/130.56					
-088		2X51	5.000/127.00	5.140/130.56					
-089		2X52	5.100/129.54	5.240/133.10					
-090		2X52	5.100/129.54	5.240/133.10					
-091		2X53	5.200/132.08	5.340/135.64					
-092		2X53	5.200/132.08	5.340/135.64					
-093		2X54	5.300/134.62	5.440/138.18					
-094		2X54	5.300/134.62	5.440/138.18					
-095		2X55	5.400/137.16	5.540/140.72					
-096		2X55	5.400/137.16	5.540/140.72		40u"/1.02u Au			
-097		2X14	1.300/33.02	1.440/36.58		50u"/1.27u Au			
-098		2X14	1.300/33.02	1.440/36.58					
-099		2X29	2.800/71.12	2.940/74.68					
-100		2X29	2.800/71.12	2.940/74.68					
-101		2X26	2.500/63.50	2.640/67.06					
-102		2X26	2.500/63.50	2.640/67.06		50u"/1.27u Au			
-103		2X7	.600/15.24	.740/18.80		40u"/1.02u Au			
-104	HT NYLON	2X30	2.900/73.66	3.040/77.22	.0035/.089	50u"/1.27u Au			
-105									
-106									
-107	HT NYLON	2X8	.700/17.78	.840/21.34	.0035/.089	50u"/1.27u Au			
65000-108	HT NYLON	2X15	1.400/33.56	1.540/39.12	.0035/.089	50u"/1.27u Au			NOTE 5, 6



Copyright FCI

mat'l. code		surface ISO 1302 <input checked="" type="checkbox"/>		tolerance ISO 406		projection		product family CARD CONN.	
ltr		ecn no		date		tolerances unless otherwise specified		title	
AX						.xx±.01/.3		BERGCON HORIZ. CARD CONN	
						linear .xxx±.005/.13		DOUBLE ROW .100/2.54 cc	
						0'±2'		scale 1:1	
						dr M.CLOUSER 6/7/94		dwg no sheet5 of11size	
						enr H.SUNDY 6/7/94		65000 A3	
						chr H.SUNDY 6/7/94		type Product Customer Drawing	
						appd H.SUNDY 6/7/94			
sheet index		revision sheet							

PRODUCT NUMBER	HOUSING MATERIAL	NO. OF POS	DIM A	DIM B	SPRING THICKNESS	BODY PLATING THICKNESS	SPECIAL MARKINGS AND MISCELLANEOUS	CUSTOMER RESTRICTED	LEAD FREE OPTION	
65000-109	HT NYLON	2X20	1.900/48.26	2.040/51.82	.0035/.089	50u"1.27u Au			NOTE 5, 6	
-110		2X24	2.300/58.42	2.440/61.98	.0035/.089	50u"1.27u Au				
-111		OBSOLETE								
-112		2X4	.300/7.62	.440/11.18	.0035/.089	50u"1.27u Au				
-113		2X8	.700/17.78	.840/21.34	.0048/.122	40u"/1.02u Au				
-114		2X5	.400/10.16	.540/13.72	.0035/.089					
-115		2X5	.400/10.16	.540/13.72						
-116		2X6	.500/12.70	.640/16.26						
-117		2X6	.500/12.70	.640/16.26						
-118		2X7	.600/15.24	.740/18.80						
-119		2X1	.000/.00	.140/3.56		40u"/1.02u Au				
-120		2X4	.300/7.62	.440/11.18		50u"1.27u Au				
-121		2X6	.500/12.70	.640/16.26						
-122		2X8	.700/17.78	.840/21.34						
-123		2X10	.900/22.86	1.040/26.42						
-124		2X12	1.100/27.94	1.240/31.50						
-125		2X14	1.300/33.02	1.440/36.56		50u"1.27u Au				
-126		2X1	.000/.00	.140/3.56		40u"/1.02u Au				
-127		2X2	.100/2.54	.240/6.10						
-128		2X2	.100/2.54	.240/6.10						
-129		2X3	.200/5.08	.340/8.64						
-130		2X3	.200/5.08	.340/8.64						
-131		2X4	.300/7.62	.440/11.18						
-132		2X4	.300/7.62	.440/11.18	.0035/.089					
-133		2X8	.700/17.78	.840/21.34	.0048/.122					
-134		2X65	6.400/162.56	6.540/166.12	.0035/.089					
-135		2X65	6.400/162.56	6.540/166.12	.0035/.089					
-136		2X45	4.400/111.76	4.540/115.32	.0048/.122					
-137		2X48	4.700/119.38	4.840/122.94	.0048/.122					
-138		2X56	5.500/139.70	5.640/143.56	.0035/.089					
-139		2X56	5.500/139.70	5.640/143.56						
-140		2X57	5.600/142.24	5.740/145.80						
-141		2X57	5.600/142.24	5.740/145.80						
-142		2X58	5.700/144.78	5.840/148.34						
-143		2X58	5.700/144.78	5.840/148.34						
65000-144	HT NYLON	2X59	6.800/147.32	5.940/150.88	.0035/.089	40u"/1.02u Au			NOTE 5, 6	



Copyright FCI

mat'l. code		surface ISO 1302 <input checked="" type="checkbox"/>		tolerance ISO 406 ISO 1101		projection 		product family CARD CONN.	
ltr	ecn no	dr	date	tolerances unless otherwise specified					
AX				angles	linear	.xx±.01/.3	INCH/MM		title
				0'±2'		.xxx±.005/.13	scale 1:1		BERGCON HORIZ. CARD CONN DOUBLE ROW .100/2.54 cc
						.xxxx±.0020/.051			dwg no
				dr	M.CLOUSER	6/7/94			sheet 6 of 11 size
				enr	H.SUNDY	6/7/94			65000 A3
				chr	H.SUNDY	6/7/94			type
				appd	H.SUNDY	6/7/94			Product Customer Drawing
sheet index	revision sheet								

PRODUCT NUMBER	HOUSING MATERIAL	NO. OF POS	DIM A	DIM B	SPRING THICKNESS	BODY PLATING THICKNESS	SPECIAL MARKINGS AND MISCELLANEOUS	CUSTOMER RESTRICTED	LEAD FREE OPTION
65000-145	HT NYLON	2X59	6.800/147.32	5.940/150.88	.0035/.089	40u"/1.02u Au			NOTE 5, 6
-146		2X60	5.900/149.86	6.040/153.52					
-147		2X60	5.900/149.86	6.040/153.52					
-148		2X61	6.000/152.40	6.140/155.96					
-149		2X61	6.000/152.40	6.140/155.96					
-150		2X62	6.100/154.94	6.240/158.40					
-151		2X62	6.100/154.94	6.240/158.40					
-152		2X63	6.200/157.48	6.340/161.04					
-153		2X63	6.200/157.48	6.340/161.04					
-154		2X64	6.300/160.02	6.440/163.58					
-155		2X64	6.300/160.02	6.440/163.58					
-156		2X23	2.200/55.88	2.320/58.93		40u"/1.02u Au			
-157		2X34	3.300/83.82	3.440/87.38	.0035/.089	50u"/1.27u Au			
-158		2X9	.800/20.32	.940/23.88	.0048/.122	40u"/1.02u Au			
-159		2X12	1.100/27.94	1.240/31.50	.0048/.122	40u"/1.02u Au			
-160									
-161									
-162									
-163		2X52	5.100/129.54	5.220/132.59	.0035/.089	40u"/1.02u Au		RESTRICTED	
-164		2X9	.900/20.32	.920/23.37					
-165		2X14	1.300/33.02	1.420/36.07					
-166		2X19	1.800/45.72	1.920/48.77					
-167		2X20	1.900/48.26	2.020/51.82					
-168		2X23	2.200/55.88	2.320/58.93					
-169		2X26	2.500/63.50	2.620/66.57					
-170		2X48	4.700/119.38	4.820/122.43					
-171		2X5	.400/10.16	.520/13.21					
-172		2X25	2.400/60.96	2.520/64.01					
-173		2X33	3.200/81.28	3.320/84.33					
-174		2X30	2.900/73.66	3.040/77.22					
-175		2X32	3.100/78.74	3.240/82.30		40u"/1.02u Au			
-176		2X45	4.400/111.76	4.540/115.32		40u"/1.02u Au		RESTRICTED	
-177		2X34	3.300/83.82	3.440/87.38		50u"/1.27u Au			
-178		2X20	1.900/48.26	2.040/51.82		50u"/1.27u Au			
-179		2X10	.900/22.86	1.040/26.42		50u"/1.27u Au			
65000-180	HT NYLON	2X40	3.900/99.06	4.040/102.62	.0035/.089	40u"/1.02u Au		RESTRICTED	NOTE 5, 6



FCIconnect.com

Copyright FCI

mat'l. code		surface ISO 1302 ✓		tolerance ISO 406 ISO 1101		projection ⊕		product family CARD CONN.	
ltr	ecn no	dr	date	tolerances unless otherwise specified		INCH/MM		title	
AX				angles	linear	.xx±.01/.3		BERGCON HORIZ. CARD CONN	
				0'±2'		.xxx±.005/.13		DOUBLE ROW .100/2.54 cc	
						.xxxx±.0020/.051		scale 1:1	
		dr	M.CLOUSER	6/7/94		FCI		dwg no sheet 7 of 11 size	
		enr	H.SUNDY	6/7/94				65000 A3	
		chr	H.SUNDY	6/7/94				type Product Customer Drawing	
		appd	H.SUNDY	6/7/94					
sheet index	revision sheet								

form: A3

PRODUCT NUMBER	HOUSING MATERIAL	NO. OF POS	DIM A	DIM B	SPRING THICKNESS	BODY PLATING THICKNESS	SPECIAL MARKINGS AND MISCELLANEOUS	CUSTOMER RESTRICTED	LEAD FREE OPTION
65000-181	HT NYLON	2X50	4.900/124.46	5.040/128.02	.0035/.089	40u"/1.02u Au		RESTRICTED	NOTE 5, 6
-182		2X14	2.000/50.80	2.140/54.36	.0035/.089	40u"/1.02u Au		RESTRICTED	
-183		2X50	4.900/124.46	5.040/128.02	.0030/.076	50u"/1.27u Au			
-184		2X44	4.300/109.22	4.440/112.78	.0035/.089	40u"/1.02u Au			
-185		2X6	.500/12.70	.640/16.26	.0035/.089	50u"/1.27u Au		RESTRICTED	
-186		2X22	2.100/53.34	2.240/56.90	.0035/.089	50u"/1.27u Au		RESTRICTED	
-187		2X10	.900/22.86	1.040/26.42	.0048/.122	100u"/2.54u TIN LEAD			
-201		2X1	.000/.00	.140/3.56	.0035/.089				
-202		2X2	.100/2.54	.240/6.10					
-203		2X3	.200/5.08	.340/8.64					
-204		2X4	.300/7.62	.440/11.18					
-205		2X5	.400/10.16	.540/13.72					
-206		2X6	.500/12.70	.640/16.26					
-207		2X7	.600/15.24	.740/18.80					
-208		2X8	.700/17.78	.840/21.34					
-209		2X9	.800/20.32	.940/23.88					
-210		2X10	.900/22.86	1.040/26.42					
-211		2X11	1.000/25.40	1.140/28.96					
-212		2X12	1.100/27.94	1.240/31.50					
-213		2X13	1.200/30.48	1.340/34.04					
-214		2X14	1.300/33.02	1.440/36.58					
-215		2X15	1.400/35.56	1.540/39.12					
-216		2X16	1.500/38.10	1.640/41.66					
-217		2X17	1.600/40.64	1.740/44.20					
-218		2X18	1.700/43.18	1.840/46.74					
-219		2X19	1.800/45.72	1.940/49.28					
-220		2X20	1.900/48.26	2.040/51.82					
-221		2X21	2.000/50.80	2.140/54.36					
-222		2X22	2.100/53.34	2.240/56.90					
-223		2X23	2.200/55.68	2.340/59.44					
-224		2X24	2.300/58.42	2.440/61.98					
-225		2X25	2.400/60.96	2.540/64.52					
-226		2X26	2.500/63.50	2.640/67.06					
-227		2X27	2.600/66.04	2.740/69.60					
-228		2X28	2.700/68.58	2.840/72.14					
65000-229	HT NYLON	2X29	2.800/71.12	2.940/74.68	.0035/.089	100u"/2.54u TIN LEAD			NOTE 5, 6



FCIconnect.com

Copyright FCI

mat'l. code		surface ISO 1302 <input checked="" type="checkbox"/>	tolerance ISO 406 ISO 1101	projection 	product family CARD CONN.
ltr	ecn no	dr	date	tolerances unless otherwise specified	title
AX				angles linear .xx±.01/.3 0'±2' .xxx±.005/.13 .xxxx±.0020/.051	BERGCON HORIZ. CARD CONN DOUBLE ROW .100/2.54 cc
		dr	M.CLOUSER	6/7/94	dwg no sheet 8 of 11 size
		enr	H.SUNDY	6/7/94	65000 A3
		chr	H.SUNDY	6/7/94	type Product Customer Drawing
		appd	H.SUNDY	6/7/94	
sheet index	revision sheet				



PRODUCT NUMBER	HOUSING MATERIAL	NO. OF POS	DIM A	DIM B	SPRING THICKNESS	BODY PLATING THICKNESS	SPECIAL MARKINGS AND MISCELLANEOUS	CUSTOMER RESTRICTED	LEAD FREE OPTION
65000-230	HT NYLON	2X30	2.900/73.66	3.040/77.22	.0035/.089	100u"/2.54u TIN LEAD			NOTE 5, 6
-231		2X31	3.000/76.20	3.140/79.76					
-232		2X32	3.100/78.74	3.240/82.30					
-233		2X33	3.200/81.28	3.340/84.84					
-234		2X34	3.300/83.82	3.440/87.38					
-235		2X35	3.400/86.36	3.540/89.92					
-236		2X36	3.500/88.90	3.640/92.46					
-237		2X37	3.600/91.44	3.740/95.00					
-238		2X38	3.700/93.98	3.840/97.54					
-239		2X39	3.800/96.52	3.940/100.08					
-240		2X40	3.900/99.06	4.040/102.62					
-241		2X41	4.000/101.60	4.140/105.16					
-242		2X42	4.100/104.14	4.240/107.70					
-243		2X43	4.200/106.68	4.340/110.24					
-244		2X44	4.300/109.22	4.440/112.78					
-245		2X45	4.400/111.76	4.540/115.31					
-246		2X46	4.500/114.30	4.640/117.86					
-247		2X47	4.600/116.84	4.740/120.40					
-248		2X48	4.700/119.38	4.840/122.94					
-249		2X49	4.800/121.92	4.940/125.48					
-250		2X50	4.900/124.46	5.040/128.02					
-251		2X51	5.000/127.00	5.140/130.56					
-252		2X52	5.100/129.54	5.240/133.10					
-253		2X53	5.200/132.08	5.340/135.64					
-254		2X54	5.300/134.62	5.440/138.18					
-255		2X55	5.400/137.16	5.540/140.72					
-256		2X56	5.500/139.70	5.640/143.26					
-257		2X57	5.600/142.24	5.740/145.80					
-258		2X58	5.700/144.78	5.840/148.34					
-259		2X59	5.800/147.32	5.940/150.88					
-260		2X60	5.900/149.86	6.040/153.42					
-261		2X61	6.000/152.40	6.140/155.96					
-262		2X62	6.100/154.94	6.240/158.50					
-263		2X63	6.200/157.40	6.340/161.04					
-264		2X64	6.300/160.02	6.440/163.58					
65000-265	HT NYLON	2X65	6.400/162.56	6.540/166.12	.0035/.089	100u"/2.54u TIN LEAD			NOTE 5, 6



FCJconnect.com

Copyright FCJ

mat'l. code		surface ISO 1302 <input checked="" type="checkbox"/>		tolerance ISO 406 ISO 1101		projection 		product family CARD CONN.	
ltr		ecn no		date		tolerances unless otherwise specified		title	
AX						.xx±.01/.3 linear		INCH/MM	
				0'±2'		.xxx±.005/.13 .xxxx±.0020/.051		scale 1:1	
				dr		M.CLOUSER 6/7/94		dwg no	
				enr		H.SUNDY 6/7/94		sheet 9 of 11 size	
				chr		H.SUNDY 6/7/94		65000 A3	
				appd		H.SUNDY 6/7/94		type Product Customer Drawing	
sheet index		revision sheet							



PRODUCT NUMBER	HOUSING MATERIAL	NO. OF POS	DIM A	DIM B	SPRING THICKNESS	BODY PLATING THICKNESS	SPECIAL MARKINGS AND MISCELLANEOUS	CUSTOMER RESTRICTED	LEAD FREE OPTION
65000-266	HT NYLON	2X30	2.900/73.66	3.040/77.22	.0030/.076	40u"/1.02u Au		RESTRICTED	NOTE 5, 6
-267		2X40	3.900/99.06	4.040/102.60	.0030/.076	40u"/1.02u Au		RESTRICTED	
-268		2X10	.900/22.86	1.040/26.42	.0035/.089	50u"/1.27u Au			
-269		2X11	1.000/25.40	1.140/28.96					
-270		2X13	1.200/30.48	1.340/34.04					
-271		2X14	1.300/33.02	1.440/36.58					
-272		2X15	1.400/33.56	1.540/39.12					
-273		2X17	1.600/40.64	1.740/44.20					
-274		2X20	1.900/48.26	2.040/51.82					
-275		2X21	2.000/50.80	2.140/54.36					
-276		2X22	2.100/53.34	2.240/56.90					
-277		2X25	2.400/60.96	2.540/64.52					
-278		2X26	2.500/63.50	2.640/67.06					
-279		2X30	2.900/73.66	3.040/77.22					
-280		2X32	3.100/78.74	3.240/82.30					
-281		2X34	3.300/83.82	3.440/87.38					
-282		2X35	3.400/86.36	3.540/89.92					
-283		2X37	3.600/91.44	3.740/95.00					
-284		2X39	3.800/96.52	3.940/100.08					
-285		2X40	3.900/99.06	4.040/102.60					
-286		2X41	4.000/101.60	4.140/105.16					
-287		2X44	4.300/109.22	4.440/112.78					
-288		2X46	4.500/114.30	4.640/117.88					
-289		2X47	4.600/116.84	4.740/120.40					
-290		2X49	4.800/121.92	4.940/125.48	.0035/.089				
-291		2X50	4.900/124.46	5.040/128.02	.0030/.076				
-292		2X51	5.000/127.00	5.140/130.56					
-293		2X52	5.100/129.54	5.240/133.10					
-294		2X55	5.400/137.16	5.540/140.72					
-295		2X58	5.700/144.78	5.840/148.34					
-296		2X61	6.000/152.40	6.140/155.96		50u"/1.27u Au			
-297		2X50	4.900/124.46	5.040/128.02	.0030/.076	30u"/.76u Au		RESTRICTED	
-298		2X25	2.400/60.96	2.540/64.52	.0035/.089	40u"/1.02u Au			
-299		2X40	3.900/99.06	4.040/102.60	.0035/.089	40u"/1.02u Au			
-300		2X61	6.000/152.40	6.140/155.96	.003/.076	40u"/1.02u Au			
65000-301	HT NYLON	2X65	6.400/162.56	6.540/166.12	.0035/.089	30u"/.76u Au			NOTE 5, 6



FCIconnect.com

Copyright FCI

mat'l. code		surface ISO 1302 <input checked="" type="checkbox"/>		tolerance ISO 406 ISO 1101		projection 		product family CARD CONN.	
ltr		ecn no		dr		date		title	
AX								BERGCON HORIZ. CARD CONN DOUBLE ROW .100/2.54 cc	
								dwg no 65000	
								sheet 0 of 11 size A3	
								type Product Customer Drawing	
sheet index		revision sheet							



PRODUCT NUMBER	HOUSING MATERIAL	NO. OF POS	DIM A	DIM B	SPRING THICKNESS	BODY PLATING THICKNESS	SPECIAL MARKINGS AND MISCELLANEOUS	CUSTOMER RESTRICTED	LEAD FREE OPTION
65000-302	HT NYLON	2X7	.600/15.24	.740/18.80	.0035/.089	50u"/1.27u Au		RESTRICTED	NOTE 5, 6
-303		2X19	1.800/45.72	1.940/49.28		30u"/.76u Au			
-304		2X22	2.100/53.34	2.240/56.90					
-305		2X25	2.400/60.96	2.540/64.52					
-306		2X40	3.900/99.06	4.040/102.60					
-307		2X44	4.300/109.22	4.440/112.78	.0035/.089				
-308		2X61	6.000/152.40	6.140/155.96	.0030/.076				
-309		2X10	.900/22.86	1.040/26.42	.0035/.089				
-310		2X41	4.000/101.60	4.140/105.16	.0035/.089				
-311		2X35	3.400/86.36	3.540/89.92	.0035/.089				
-312		2X59	5.800/147.32	5.940/150.88	.0030/.076				
-313		2X30	2.900/73.66	3.040/77.22	.0035/.089				
-314		2X20	1.900/48.26	2.040/51.82					
-315		2X24	2.300/58.24	2.440/61.98					
-316		2X14	1.300/33.02	1.440/36.58		30u"/0.76u Au			
-317		2X28	2.700/68.58	2.840/72.14	.0035/.089	30u"/0.76u Au			
-318		2X65	6.400/162.56	6.540/166.12	.0030/.076	50u"/1.27u Au		RESTRICTED	
-319		2X20	1.900/48.26	2.040/51.82	.0035/.089	80u"/2.04u Au		BNL ONLY	OBS.
-450		2X10	.900/22.86	1.040/26.42	.0035/.089	30u"/0.76u Au		RESTRICTED	
-451		2X9	.800/20.32	.940/23.88		50u"/1.27u Au		BNL ONLY	
-452		2X28	2.700/68.58	2.840/72.14		50u"/1.27u Au		BNL ONLY	
65000-453	HT NYLON	2X32	3.100/78.74	3.240/82.30	.0035/.089	50u"/1.27u Au		BNL ONLY	NOTE 5, 6



Copyright FCJ

mat'l. code		surface ISO 1302 <input checked="" type="checkbox"/>		tolerance ISO 406		projection		product family	
ltr		ecn no		date		tolerances unless otherwise specified		CARD CONN.	
AX						.xx±.01/.3		title	
						linear .xxx±.005/.13		BERGCON HORIZ. CARD CONN	
						.xxxx±.0020/.051		DOUBLE ROW .100/2.54 cc	
						scale 1:1		dwg no	
								sheet 11 of 11 size	
								65000 A3	
								type Product Customer Drawing	
sheet index		revision sheet							