

ARM[®] Cortex[®]-M
32-bit Microcontroller

MuMaker-PFM-NUC472
User Manual
NuMicro[®] NUC472 Series

The information described in this document is the exclusive intellectual property of Nuvoton Technology Corporation and shall not be reproduced without permission from Nuvoton.

Nuvoton is providing this document only for reference purposes of NuMicro microcontroller based system design. Nuvoton assumes no responsibility for errors or omissions.

All data and specifications are subject to change without notice.

For additional information or questions, please contact: Nuvoton Technology Corporation.

www.nuvoton.com

Table of Contents

1 Overview 6

 1.1 Introduction to ARM® mbed™ 6

 1.2 Introduction to NuMaker-PFM-NUC472 Board 6

 1.3 NUC472 Series MCU Features 7

 1.4 NuMaker-PFM-NUC472 Board Features 8

2 NuMaker-PFM-NUC472 Board Overview 10

 2.1 Front View 10

 2.2 Rear View 11

 2.3 Arduino UNO Compatible Interface 12

 2.4 System Configuration 14

 2.4.1 Power Settings 14

 2.4.2 USB Connectors 14

 2.4.3 Ethernet Connectors 14

 2.4.4 Arduino UNO Compatible Interface Connectors 14

 2.4.5 Buttons 15

 2.4.6 Power Connectors 15

 2.5 PCB Placement 16

3 Getting Started 17

 3.1 Connect to the PC Host 17

 3.2 Confirm Your PC can Access the Internet 18

 3.3 Login the ARM® mbed™ 19

 3.4 Open Mbed Compiler 21

 3.5 Compile Program 21

 3.6 Download Program 21

 3.7 Run Program 21

 3.8 Debug Program 21

4 NuMaker-PFM-NUC472 Schematics 22

 4.1 NUC472 Series MCU 22

 4.2 Nu-Link-Me 23

 4.3 Power Supply 24

 4.4 Arduino UNO Compatible Interface 25

 4.5 Reset 25

 4.6 Crystal 26

4.7 Battery26

4.8 LED27

4.9 RGB LED27

4.10 Push Buttons28

4.11 Buzzer28

4.12 RS23229

4.13 MicroSD Card29

4.14 USB OTG and Host30

4.15 Ethernet31

4.16 RS-48532

4.17 CAN32

4.18 24-bit Stereo Audio Codec33

4.19 SRAM34

4.20 MPU650035

5 REVISION HISTORY 36

List of Figures

Figure 1-1 NuMaker-PFM-NUC472 Board..... 7

Figure 2-1 Front View of NuMaker-PFM-NUC472 Board 10

Figure 2-2 Rear View of NuMaker-PFM-NUC472 Board 11

Figure 2-3 Arduino UNO Compatible Interface 12

Figure 2-4 Front Placement 16

Figure 2-5 Back Placement..... 16

Figure 3-1 Connect to PC Host 17

Figure 3-2 Nu-Link in “Devices and Printers” and “Device Manager” 18

Figure 3-3 “MBED” Disk 18

Figure 3-4 Contents in “MBED” Disk..... 19

Figure 3-5 Login Web-page in ARM® mbed™ 19

Figure 3-6 Signup to Create A New Account 20

Figure 3-7 Log in ARM® mbed™ on NUC472 20

Figure 3-8 ARM® mbed™ Compiler Based on NUC472 21

Figure 4-1 NUC472 Series Pin Assignment..... 22

Figure 4-2 Nu-Link-Me Circuit 23

Figure 4-3 Power Circuit and Configurations 24

Figure 4-4 Arduino UNO Compatible Interface 25

Figure 4-5 Reset Circuit 25

Figure 4-6 External Crystal Circuit 26

Figure 4-7 Battery Circuit 26

Figure 4-8 Power LED and IO LED Circuit 27

Figure 4-9 RGB LED Circuit..... 27

Figure 4-10 Push Buttons Circuit 28

Figure 4-11 Buzzer Circuit 28

Figure 4-12 RS232 Circuit..... 29

Figure 4-13 MicroSD Card Circuit 29

Figure 4-14 USB OTG and Host Circuit..... 30

Figure 4-15 Ethernet Circuit 31

Figure 4-16 RS-485 Circuit and Connectors..... 32

Figure 4-17 CAN Circuit and Connectors 32

Figure 4-18 Audio Codec Circuit 33

Figure 4-19 External SRAM Memory Circuit..... 34

Figure 4-20 MPU6500 Circuit..... 35

List of Tables

Table 2-1 Arduino UNO Interface Mapping with NUC472 GPIO 13
Table 2-2 Power Mode Settings 14

1 OVERVIEW

This user manual is aimed to give users a fast introduction to the use of ARM® mbed™ and NuMaker-PFM-NUC472 board.

1.1 Introduction to ARM® mbed™

The ARM® mbed™ IoT Device Platform provides the operating system, cloud services, tools and developer ecosystem to make the creation and deployment of commercial, standards-based IoT solutions possible.

The ARM® mbed™ allows IoT devices to collaborate and communicate with each other on the basis of transparency - otherwise each of the devices will not be able to talk to each other or to the cloud. For more detailed information about ARM® mbed™, user can visit the related ARM® mbed™ websites as the follows:

ARM® mbed™ homepage: www.mbed.com/en/

Software homepage: developer.mbed.org/handbook/Homepage

Official C/C++ SDK: developer.mbed.org/users/mbed_official/code/mbed/

1.2 Introduction to NuMaker-PFM-NUC472 Board

The NuMaker-PFM-NUC472 is a development board based on a Cortex®-M4 microcontroller (MCU) – NUC472 series which has very rich peripherals.

This board is provided by Nuvoton and created specially to support the ARM® mbed™ IoT Device Platform, and let user easily to develop the IoT application program on this board. The NuMaker-PFM-NUC472 also provides user many useful and powerful learning materials for how to develop and verify the application programs through the peripherals and interfaces on MCU and this board.

Furthermore, this board also provides an Arduino UNO compatible interface for user to develop the specific function with any of Arduino modules or kits. Regarding to the Arduino, user can link directly to the Wikipedia website: en.wikipedia.org/wiki/Arduino to get more detailed introductions.

The NuMaker-PFM-NUC472 board consists of NUC472 Platform and Nu-Link-Me ICE Bridge. Figure 1-1 shows the NuMaker-PFM-NUC472 board.

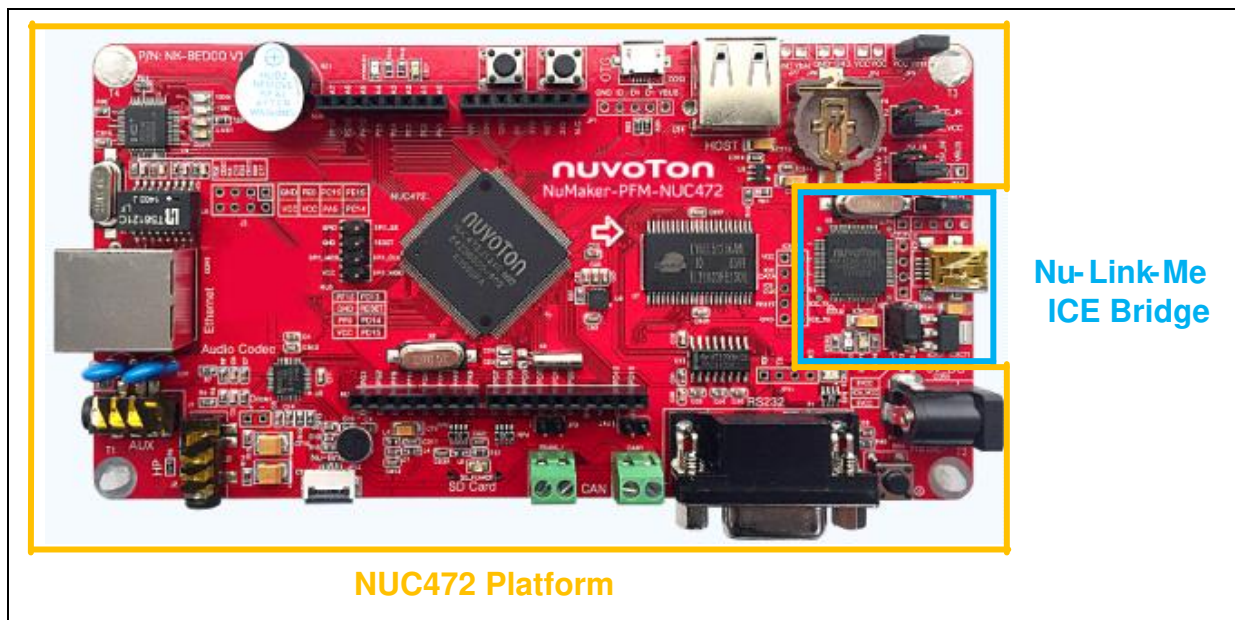

Figure 1-1 NuMaker-PFM-NUC472 Board

The left portion of this board is the NUC472 Platform that includes the target chip NUC472 MCU which embedded Cortex[®]-M4 core with DSP extensions and a Floating Point Unit (FPU) and the other related on-board application parts and connectors.

The right portion of this board is a Nu-Link-Me ICE Bridge based on the SWD (Serial Wire Debug) interface connected with the target chip, allowing user to program the application code to the flash of target chip through the USB port from PC Host.

For more information on the NuMaker-PFM-NUC472 board for the ARM[®] mbed[™] Device Platform, please visit the ARM[®] mbed[™] hardware board website:

www.mbed.com/en/development/hardware/boards/nuvotontechnology/nuvoton_nuc472/

1.3 NUC472 Series MCU Features

- NUC472JI8AE in LQFP144 package
- ARM[®] Cortex[®]-M4 core running up to 84 MHz with DSP extensions and FPU (Floating Point Unit)
- Build-in LDO for wide operating voltage ranged from 2.5 V to 5.5 V
- 512 Kbytes Flash
- 64 Kbytes SRAM
- External Bus Interface (EBI)
- GPIO (114)
- Peripheral DMA (PDMA)
- Timer (4)
- PWM (16)
- WDT and WWDT

- RTC
- UART (6)
- Smart Card (ISO-7816-3) Host Interface (6)
- PS/2 Device
- I²C (5)
- SPI (4)
- I2S (2)
- USB OTG / FS Host / HS Device
- CAN (2)
- Ethernet MAC
- SD Host
- Cryptographic Accelerator
- CRC
- ADC (2 x 16-ch)
- Comparator (3)
- OP (2)

For more detailed information about the NuMicro[®] Family NUC472 series, please directly visit Nuvoton website:

Nuvoton ARM[®] Cortex[®]-M4 MCUs: www.nuvoton.com/hq/products/microcontrollers/arm-cortex-m4-mcus/?_locale=en

NUC472 Series Datasheet (DS): www.nuvoton.com/hq/products/microcontrollers/arm-cortex-m4-mcus/Data-Sheet/?_locale=en&resourcePage=Y

NUC472 Series Technical Reference Manual (TRM): www.nuvoton.com/hq/products/microcontrollers/arm-cortex-m4-mcus/Technical-Reference-Manual/?_locale=en&resourcePage=Y

1.4 NuMaker-PFM-NUC472 Board Features

- On board Nu-Link-Me ICE Bridge (Mass storage as USB Disk drive) for drag and drop programming
- Arduino UNO compatible interface
- On board 1 Mbytes SRAM
- Audio codec (NAU8822LYG) with Microphone, Line In and Headphone Out
- Ethernet for network application
- USB OTG and Host
- MicroSD Card slot for T-Flash
- 3-axis Accelerometer and 3-axis Gyroscope (MPU6500)

- RS232 transceiver with UART COM port
- RS485 transceiver with connectors
- CAN transceiver with connectors
- Two push buttons
- Buzzer
- RGB LED
- Battery for RTC

2 NUMAKER-PFM-NUC472 BOARD OVERVIEW

2.1 Front View

Figure 2-1 shows the main components and connectors from the front side of NuMaker-PFM-NUC472 board.

The following lists components and connectors from the front view:

- Target Chip: NUC472J18AE (U1)
- Nu-Link-Me ICE Bridge: ICE Controller NUC12SRE3DE (ICEU2), USB Mini-B connector (ICEJ1) to PC Host
- Memory: 1Mbytes SRAM LY61L51216AML (U7)
- Audio: Audio Codec NAU8822LYG (U2), Microphone (MIC1), Aux Line In (J1), Headphone (J2)
- Arduino UNO compatible interface connectors (NU1, NU2, NU3, NU4 and NU5)
- USB: USB OTG Micro-AB connector (CON2) and USB Host Type-A connector (U14)
- 3-axis Accelerometer and 3-axis Gyroscope: MPU6500 (U6)
- Ethernet Transceivers: IP101GA (U4)
- RS232 Transceivers: 75C3232E (U13)
- Push buttons (SW1, SW2)
- Buzzer (BZ1)
- RGB LED (RGBLED1)
- Battery (BT1)

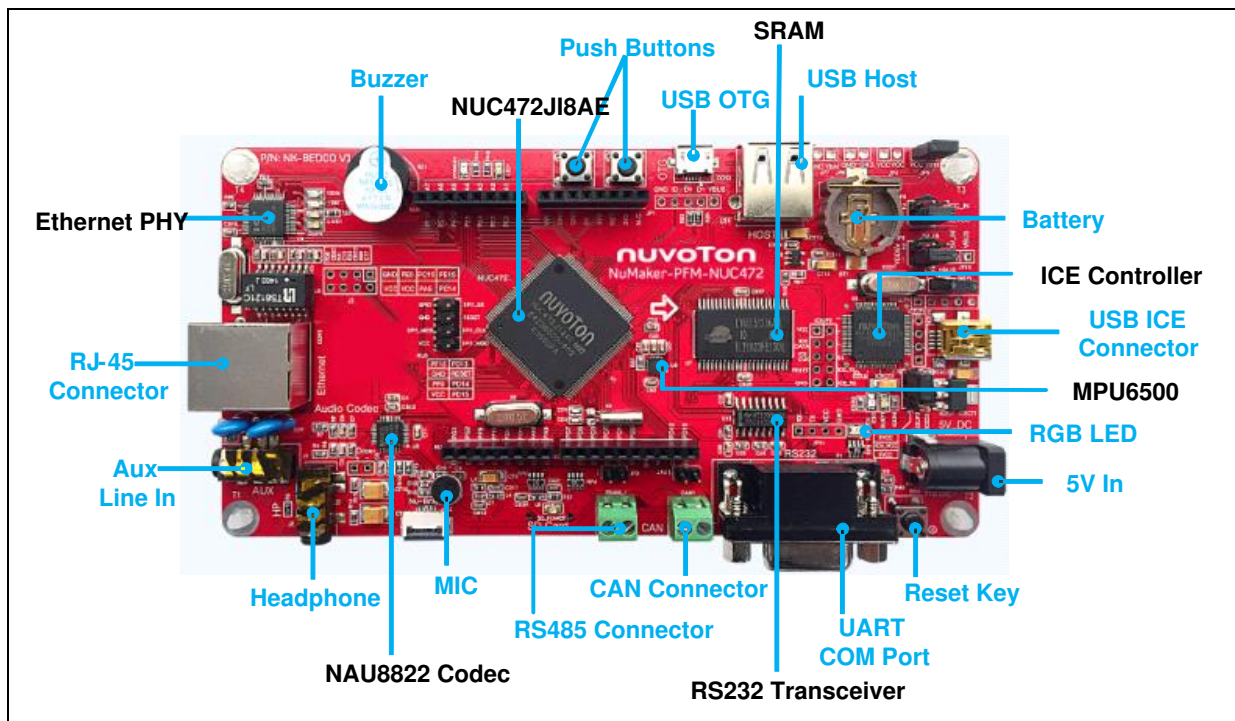

Figure 2-1 Front View of NuMaker-PFM-NUC472 Board

2.2 Rear View

Figure 2-2 shows the main components and connectors from the rear side of NuMaker-PFM-NUC472 board.

The following lists components and connectors from the rear view:

- MicroSD Card Slot: T-Flash slot (U12)
- RS485 Transceivers: SP585E (UT1)
- CAN Transceivers: SN65HVD230 (U10)
- D-type Latches: HC373 (U8 and U9)

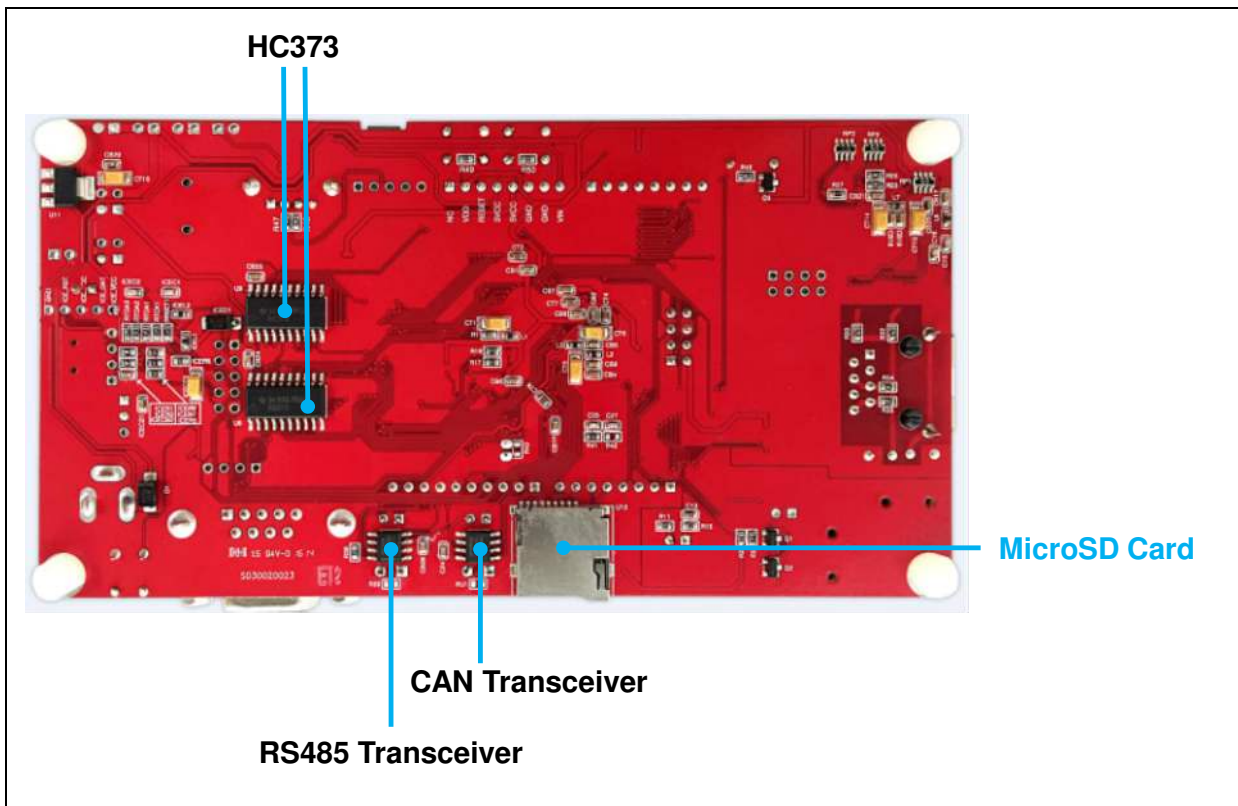

Figure 2-2 Rear View of NuMaker-PFM-NUC472 Board

2.3 Arduino UNO Compatible Interface

Figure 2-3 shows the Arduino UNO compatible interface.

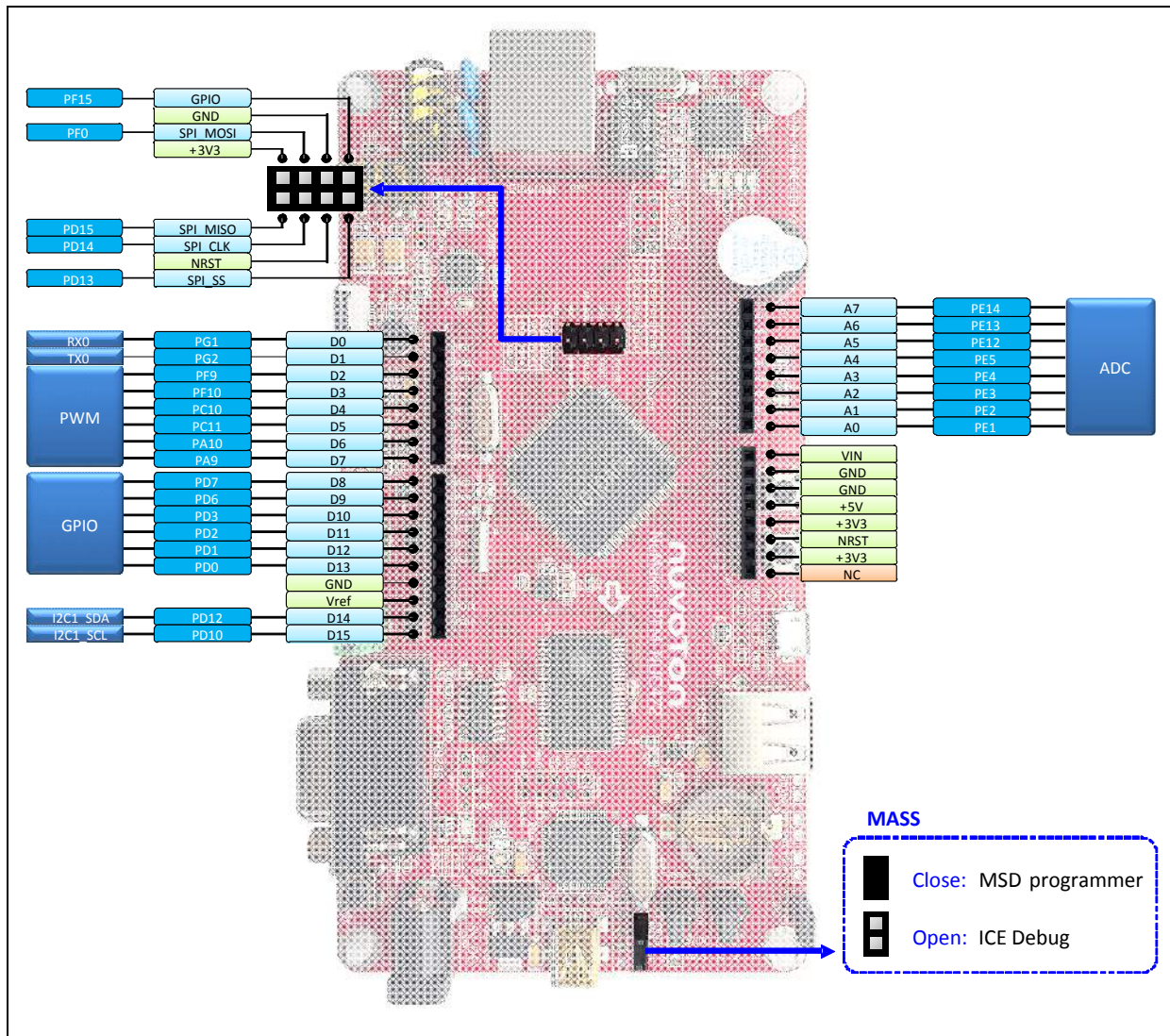

Figure 2-3 Arduino UNO Compatible Interface

Header		NuMaker-PFM-NUC472		Header		NuMaker-PFM-NUC472	
		Compatible to Arduino UNO	GPIO Pin of NUC472			Compatible to Arduino UNO	GPIO Pin of NUC472
NU1	NU1.1	NC	NC	NU4	NU4.1	ADC0	PE.1
	NU1.2	VDD	VCC		NU4.2	ADC1	PE.2
	NU1.3	MCU_RESET	RESET		NU4.3	ADC2	PE.3
	NU1.4	3VCC	3VCC		NU4.4	ADC3	PE.4
	NU1.5	5VCC	5VCC		NU4.5	ADC4	PE.5
	NU1.6	VSS	GND		NU4.6	ADC5	PE.12
	NU1.7	VSS	GND		NU4.7	ADC6	PE.13
	NU1.8	VIN	VIN		NU4.8	ADC7	PE.14
NU2	NU2.1	PWM6	PD.7	NU5	NU5.1	UART_RX0	PG.1
	NU2.2	PWM7	PD.6		NU5.2	UART_TX0	PG.2
	NU2.3	PWM8	PD.3		NU5.3	PWM0	PF.9
	NU2.4	PWM9	PD.2		NU5.4	PWM1	PF.10
	NU2.5	PWM10	PD.1		NU5.5	PWM2	PC.10
	NU2.6	PWM11	PD.0		NU5.6	PWM3	PC.11
	NU2.7	VSS	GND		NU5.7	PWM4	PA.10
	NU2.8	VREF	VREF		NU5.8	PWM5	PA.9
	NU2.9	I2C1_DAT	PD.12				
	NU2.10	I2C1_SCL	PD.10				
NU3	NU3.1	SPI0_MISO	PD.15				
	NU3.2	VCC	VCC				
	NU3.3	SPI0_CLK	PD.14				
	NU3.4	SPI0_MOSI	PF.0				
	NU3.5	MCU_RESET	RESET				
	NU3.6	VSS	GND				
	NU3.7	SPI0_SS	PD.13				
	NU3.8	GPIO	PF.15				

Table 2-1 Arduino UNO Interface Mapping with NUC472 GPIO

2.4 System Configuration

2.4.1 Power Settings

- **ICEJ1**: USB Mini-B connector in Nu-Link-Me to program code and supplies 5V power from PC Host.
- **CON2**: USB OTG Micro-AB connector in NuMaker-PFM-NUC472 to supply 5V power from PC Host when this USB is a device that be decided by the ID pin of OTG cable and this ID pin is low.
- **CON4**: 5V_IN Power JACK connector in NuMaker-PFM-NUC472.
- **JP8, JP10**: VDD5V voltage connectors in NuMaker-PFM-NUC472.

X: Unused.

Power Model	ICEJ1 USB Port (Mini)	CON2 USB Port (Micro)	CON4 DC JACK (5V)	JP8/JP10 VDD5V	MCU Voltage	Comment
Model 1	Connected to PC	X	X	DC 5V Output	DC 3.3 V	ICEJ1 supplies the power from PC.
Model 2	X	Connected to PC (this USB port is device)	X	DC 5V Output	DC 3.3 V	CON2 supplies the power from PC. Note: JP10 should be shorted 0R, and both pin2 and pin4 of JP8 should be shorted 0R too.
Model 3	X	X	Connected to DC JACK	DC 5V Output	DC 3.3V	Note: JP10 should be shorted 0R, and both pin2 and pin4 of JP8 should be shorted 0R too.

Table 2-2 Power Mode Settings

2.4.2 USB Connectors

- **ICEJ1**: USB Mini-B connector (ICE) in Nu-Link-Me that connects to a PC's USB Host port to program code and supply power.
- **CON2**: USB Micro-AB connector (OTG) in NuMaker-PFM-NUC472 for USB OTG application use.
- **U14**: USB Type-A connector (Host) in NuMaker-PFM-NUC472 for USB Host application use.

2.4.3 Ethernet Connectors

- **CON3**: Ethernet connector (RJ-45) in NuMaker-PFM-NUC472 for application use.

2.4.4 Arduino UNO Compatible Interface Connectors

- **NU1, NU2, NU3, NU4 and NU5**: Arduino UNO compatible pins in the NuMaker-PFM-NUC472 board.

2.4.5 Buttons

- **SW1, SW2:** Only for application use.
- **SW4:** Reset button to reset the target chip in NuMaker-PFM-NUC472.

2.4.6 Power Connectors

- **VCC:** VCC connector in the NuMaker-PFM-NUC472 board.
- **GND:** GND connector in the NuMaker-PFM-NUC472 board.

2.5 PCB Placement

Figure 2-4 and Figure 2-5 show the front and back placement of NuMaker-PFM-NUC472 board.

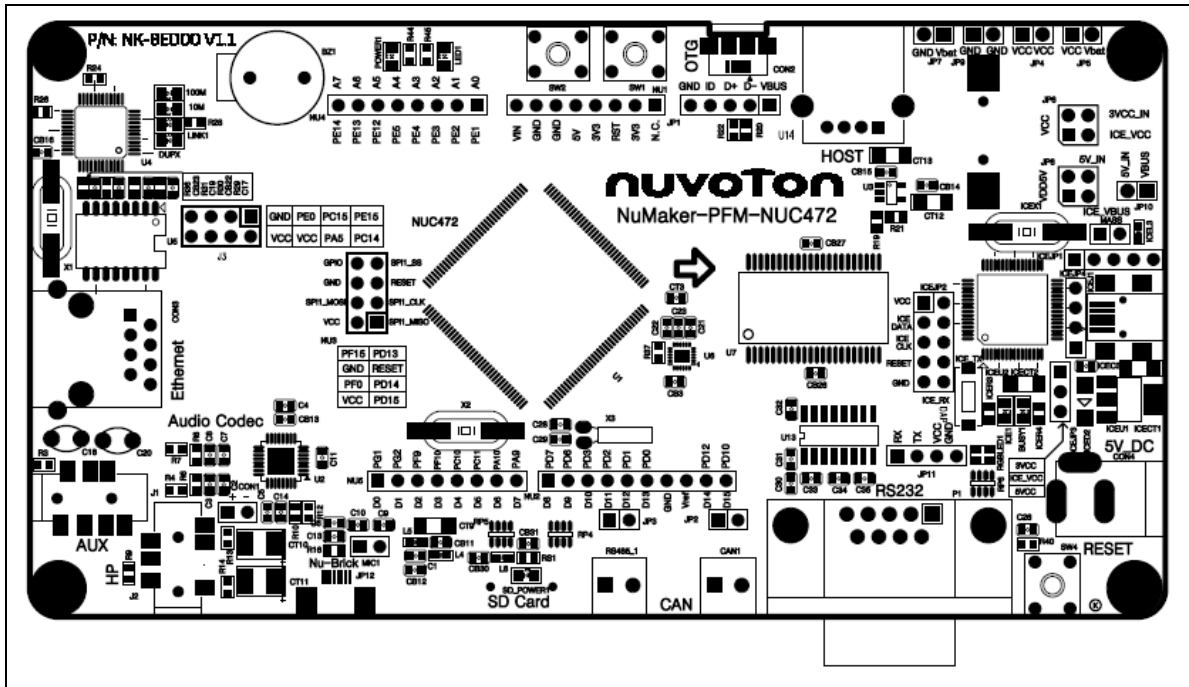

Figure 2-4 Front Placement

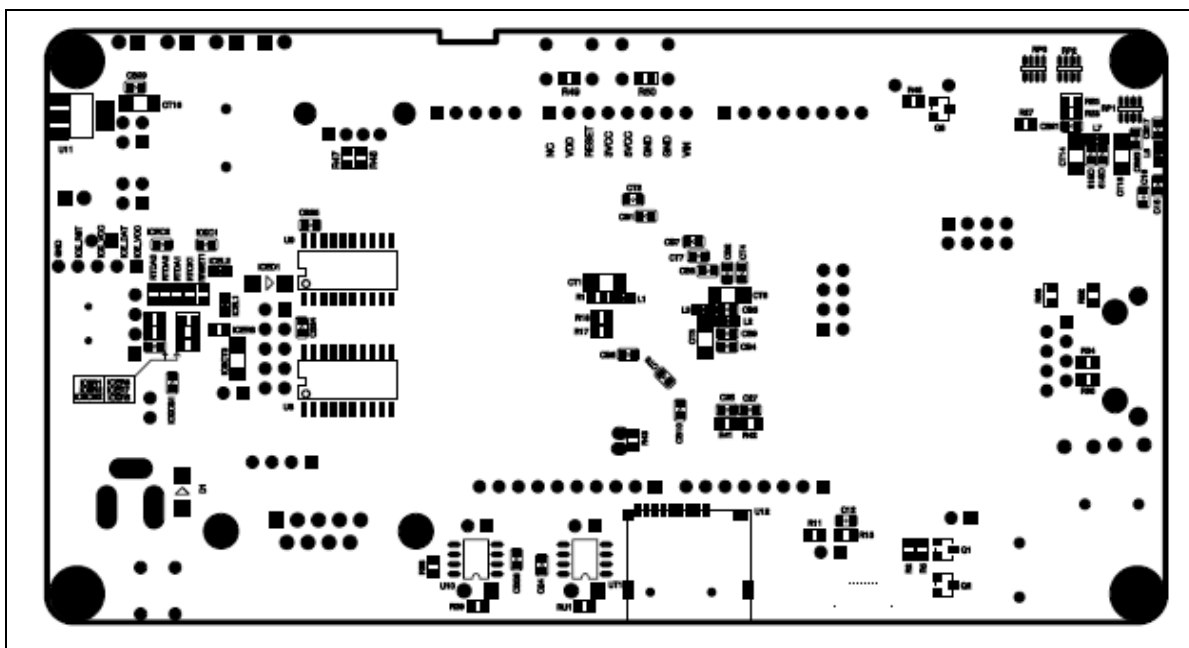

Figure 2-5 Back Placement

3 GETTING STARTED

This chapter describes the steps of using the NuMaker-PFM-NUC472 board.

3.1 Connect to the PC Host

Connect the USB Mini-B port (ICEJ1) in Nu-Link-Me to the PC Host as Figure 3-1. The PC Host will supply 5V power to this NuMaker-PFM-NUC472 board and recognize this board as USB composite device named as Nu-Link which has both Mass Storage and Virtual COM (VCOM) Port functions. The Mass Storage function is easy for user to program the bin file to the flash of target chip and user just only drags and drops the bin file to this Mass Storage disk to update program. The VCOM port function is used to print some messages on PC API, like Tera Term, through the standard UART protocol to help user to debug program.

User can check the device status from the “Devices and Printers” or “Device Manager” in your “Computer” of OS as shown in Figure 3-2.

After connecting successfully with PC Host, your PC will add-in an extra disk named as “MBED”, as shown in Figure 3-3.

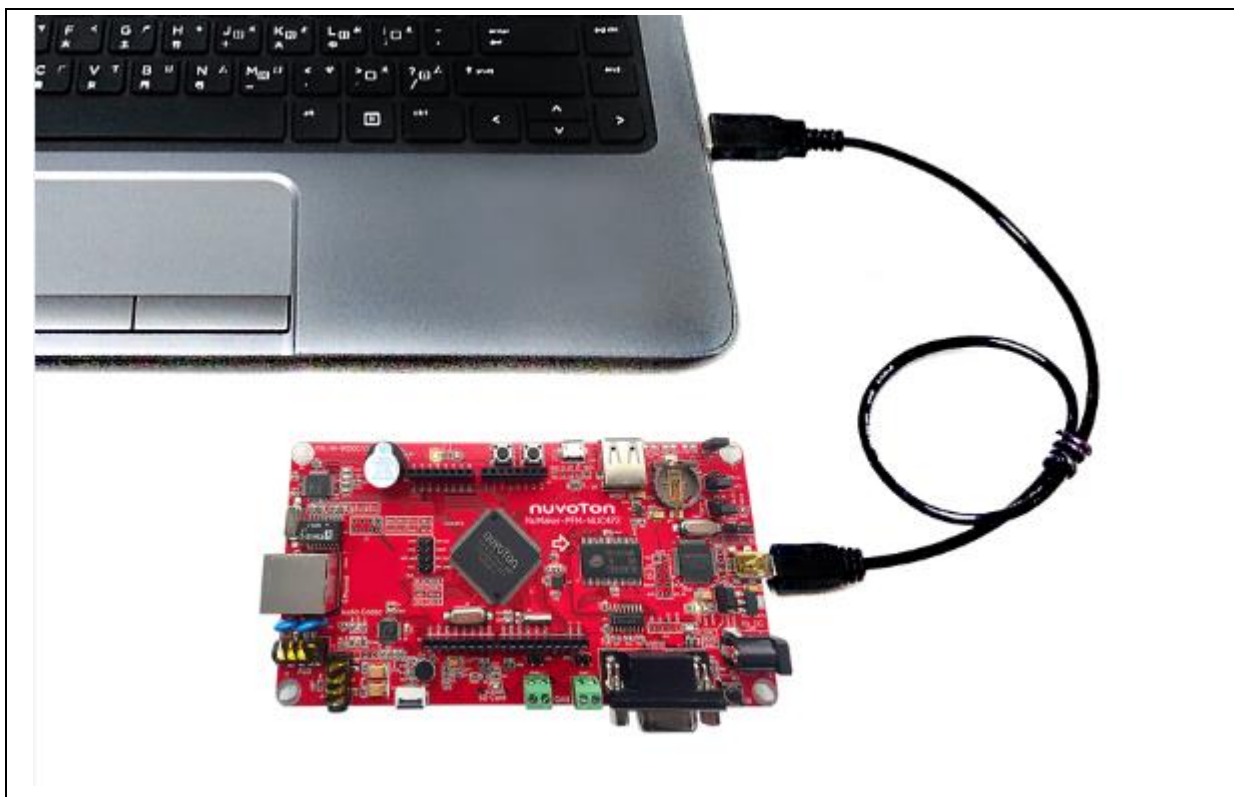

Figure 3-1 Connect to PC Host

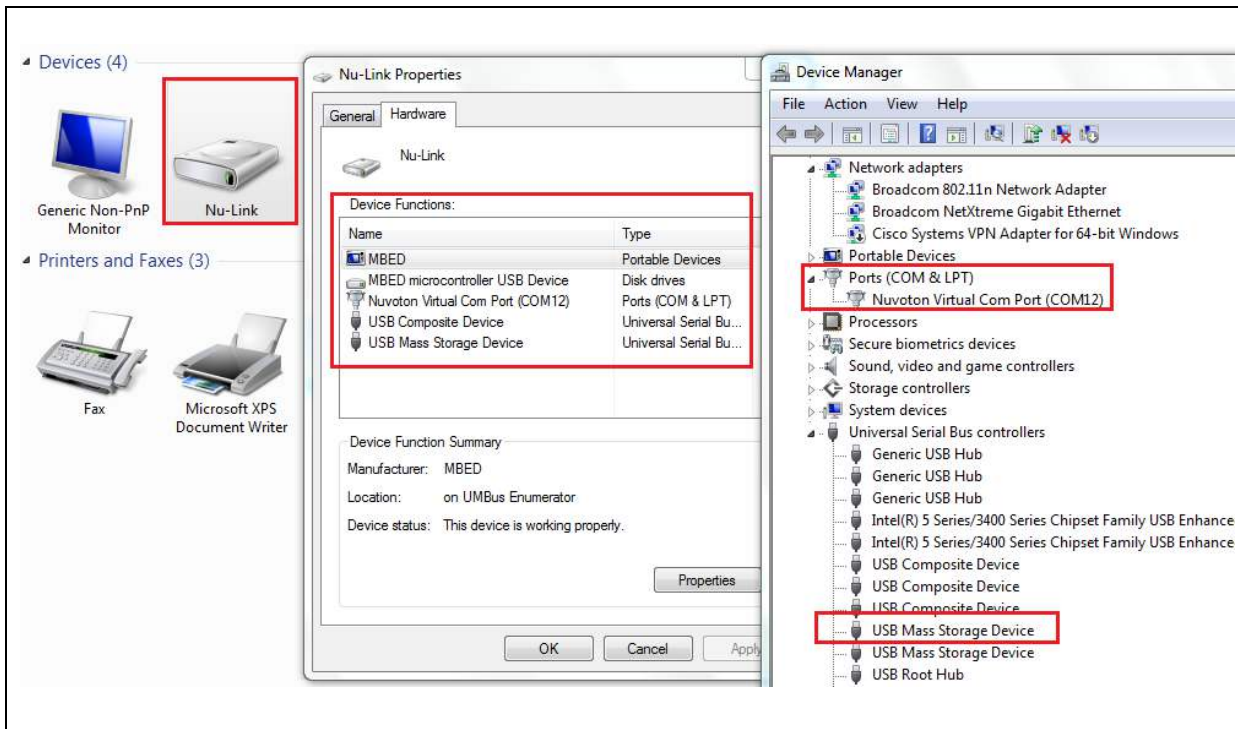

Figure 3-2 Nu-Link in “Devices and Printers” and “Device Manager”

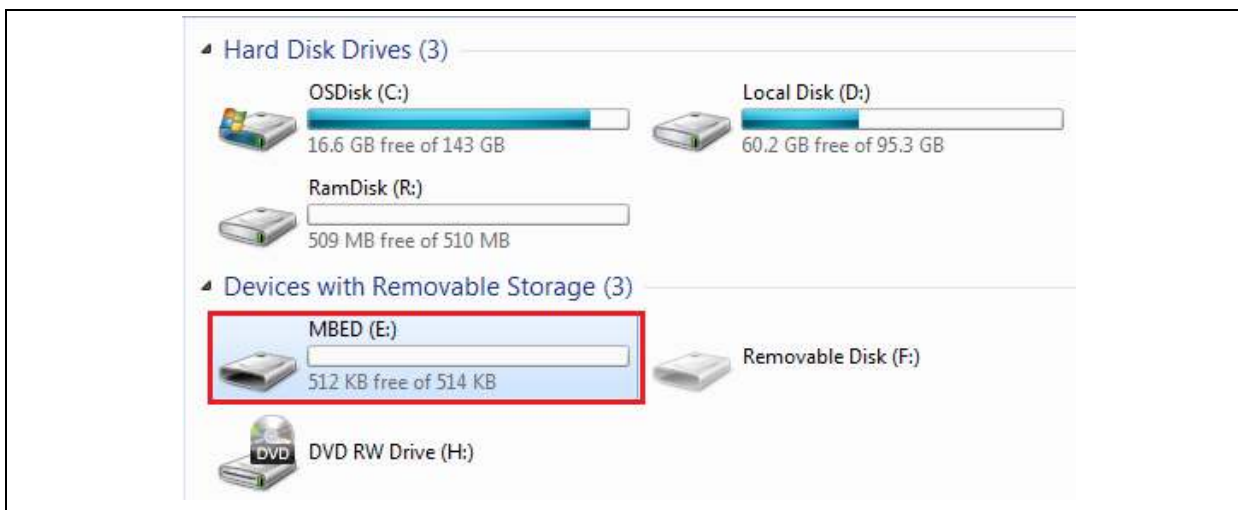

Figure 3-3 “MBED” Disk

3.2 Confirm Your PC can Access the Internet

The ARM[®] mbed[™] platform provides free and online compiler for all users. User must firstly confirm own PC can access the Internet unlimitedly.

3.3 Login the ARM® mbed™

User can double-click the “mbed.htm” in the MBED disk as shown in Figure 3-4 to link or directly link (developer.mbed.org/account/login) to the ARM® mbed™ login web-page as shown in Figure 3-5.

If you have an account created before, please login your account directly. Otherwise, choose the “Signup” icon to create a new account to register the ARM® mbed™ platform as Figure 3-6.

After logging in the ARM® mbed™ platform, user will see as the contents as shown in Figure 3-7.

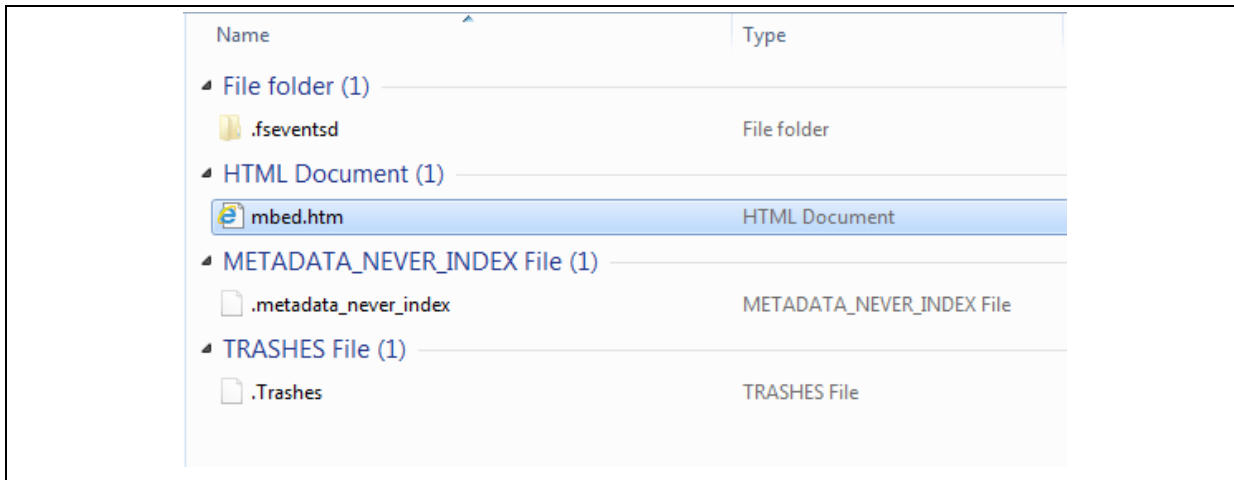

Figure 3-4 Contents in “MBED” Disk

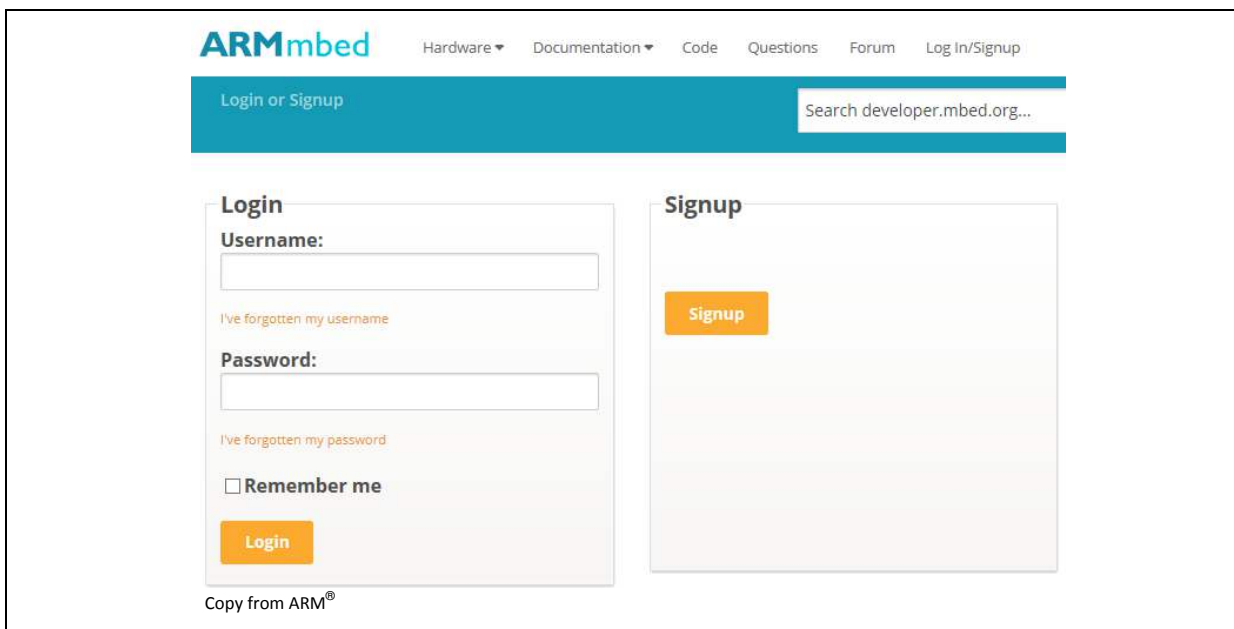

Figure 3-5 Login Web-page in ARM® mbed™

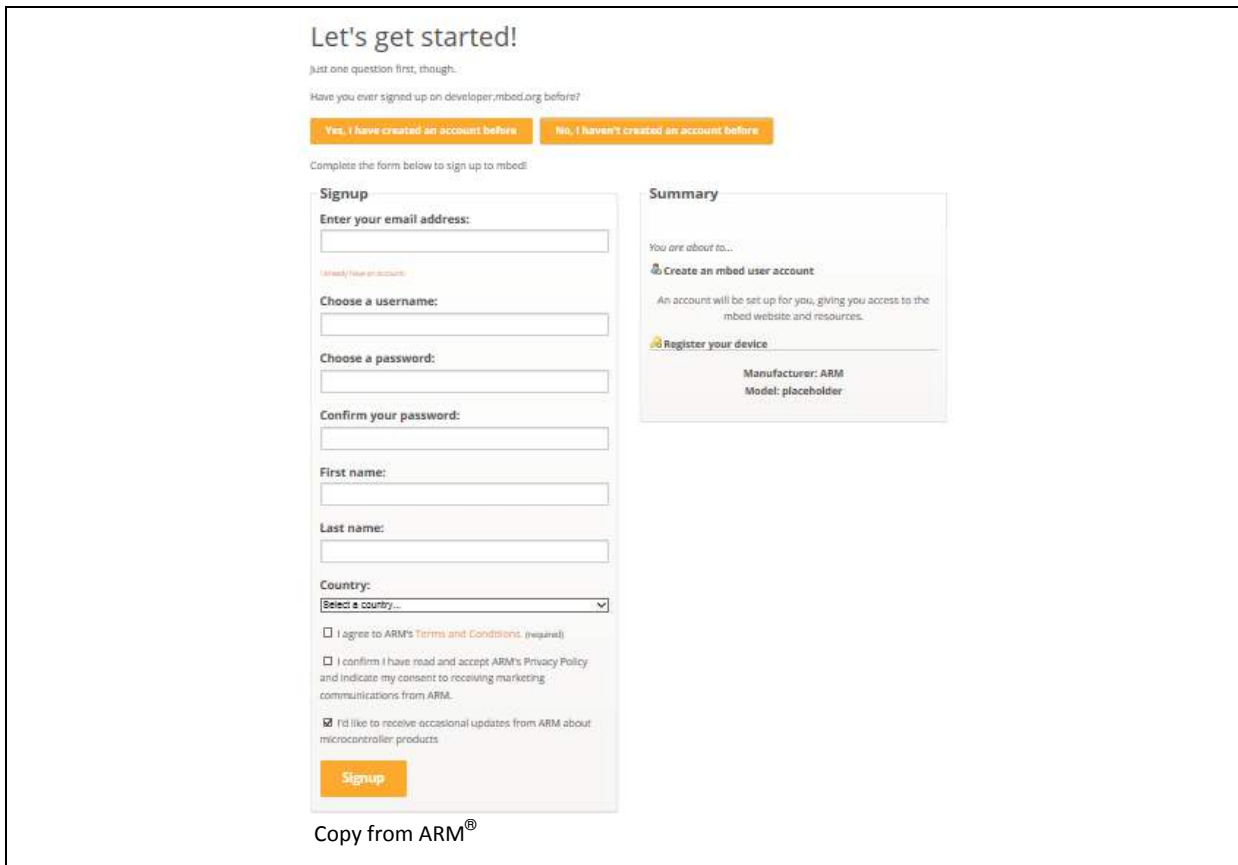

Figure 3-6 Signup to Create A New Account

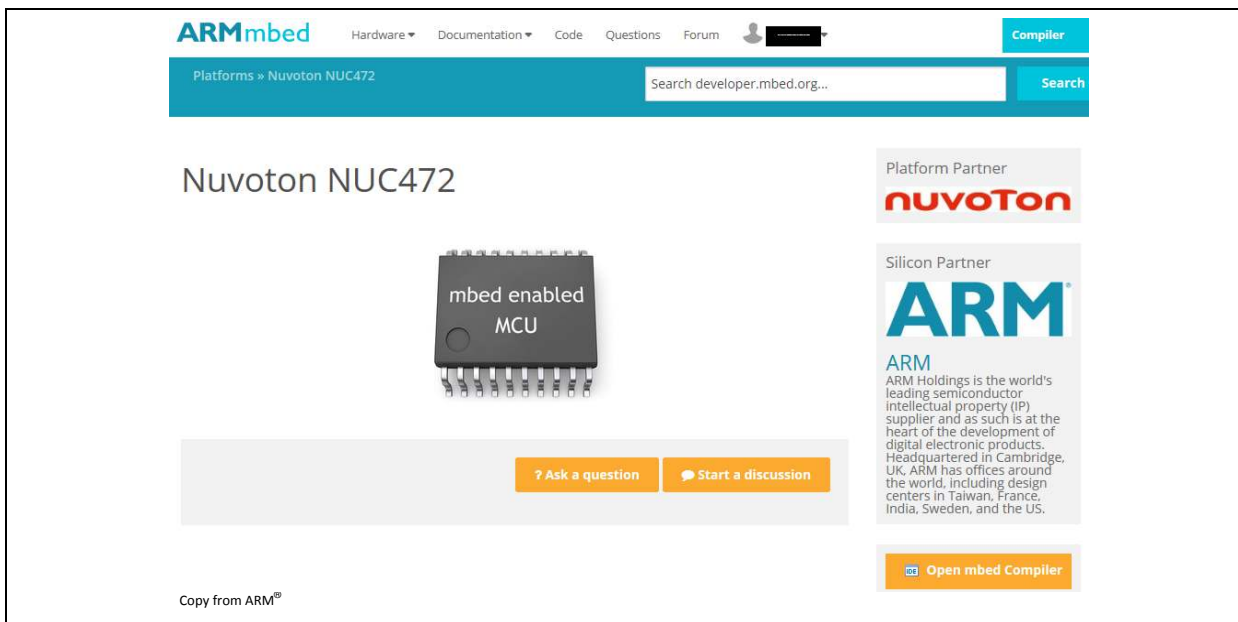

Figure 3-7 Log in ARM® mbed™ on NUC472

3.4 Open Mbed Compiler

To open the free and on-line mbed Compiler as shown in Figure 3-8, user can import a program or create a new one to develop the specific application based on the NuMaker-PFM-NUC472 board.

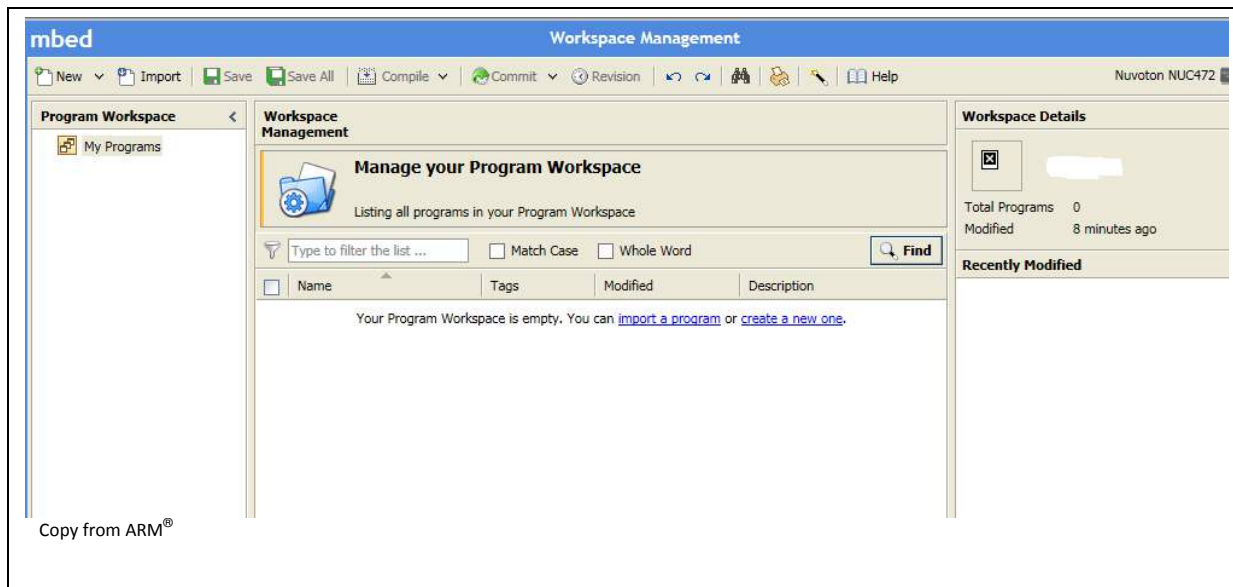

Figure 3-8 ARM® mbed™ Compiler Based on NUC472

3.5 Compile Program

User can click the “Compile” icon to compile the program on-line and check the compile results and fix the errors if needed.

3.6 Download Program

User just needs to drag and drop the bin file to the “MBED” disk to program the flash of target chip on the NuMaker-PFM-NUC472 board.

3.7 Run Program

User can press the RESET button (SW4) to reset the target chip and run the program freely on the NuMaker-PFM-NUC472 board.

3.8 Debug Program

User can write some printf() functions to show messages in the program to debug the program. The Nu-Link-Me ICE Bridge also supports the VCOM Port function to print some messages on PC API, like Tera Term, through the standard UART protocol.

4 NUMAKER-PFM-NUC472 SCHEMATICS

4.1 NUC472 Series MCU

Figure 4-1 shows the pin assignment of the NUC472 series MCU.

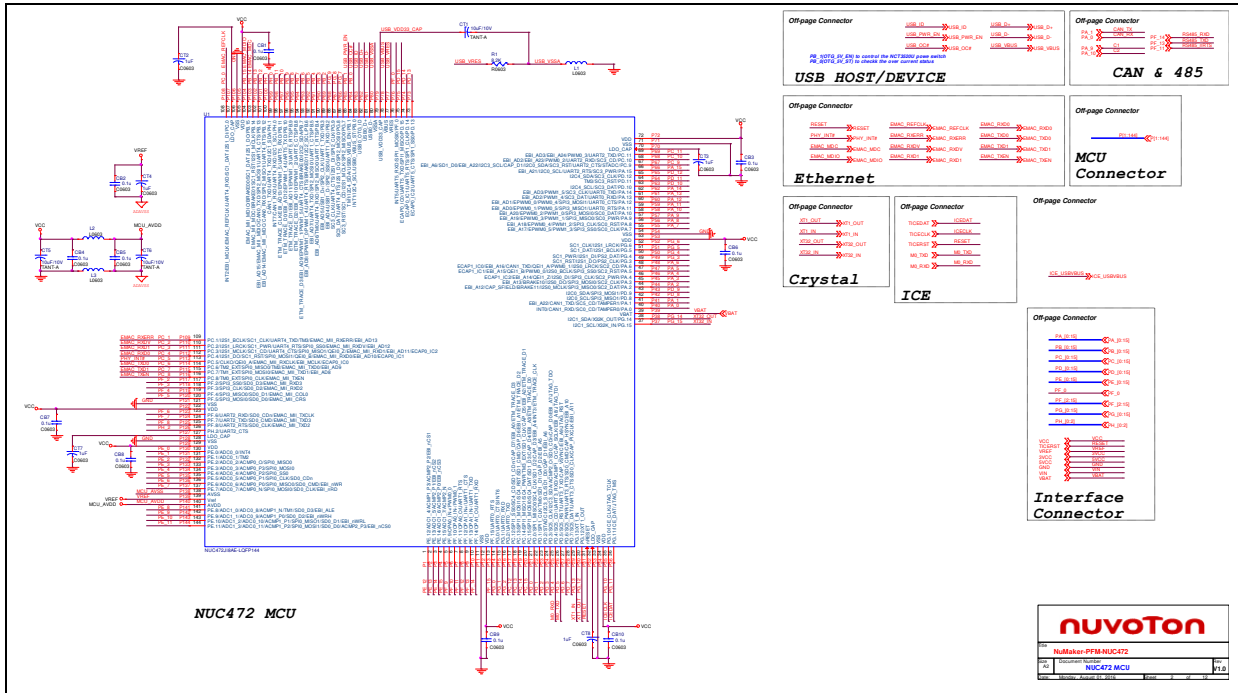

Figure 4-1 NUC472 Series Pin Assignment

4.2 Nu-Link-Me

Figure 4-2 shows the Nu-Link-Me circuit, which is a USB-to-SWD bridge used to program code to the target chip.

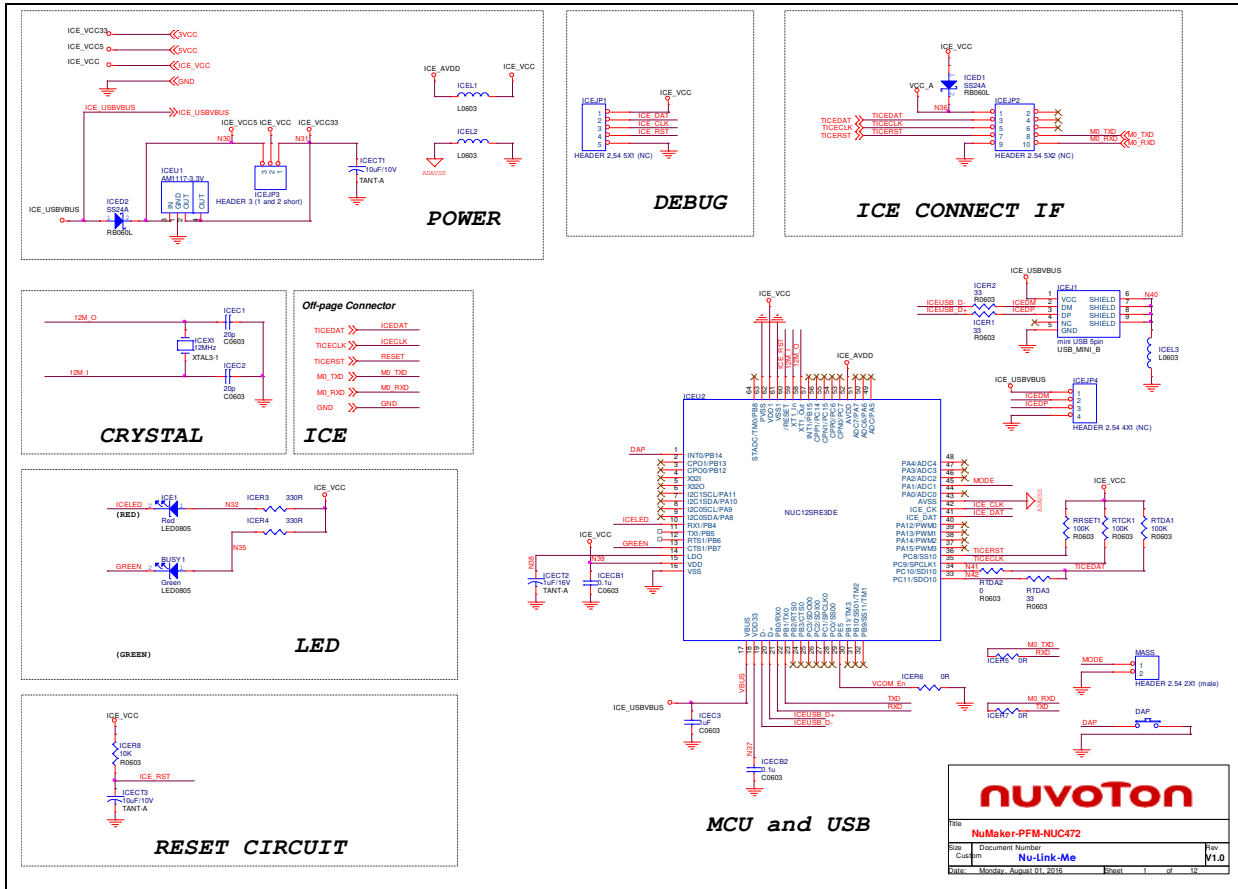

Figure 4-2 Nu-Link-Me Circuit

4.3 Power Supply

Figure 4-3 shows power configurations of NuMaker-PFM-NUC472 board.

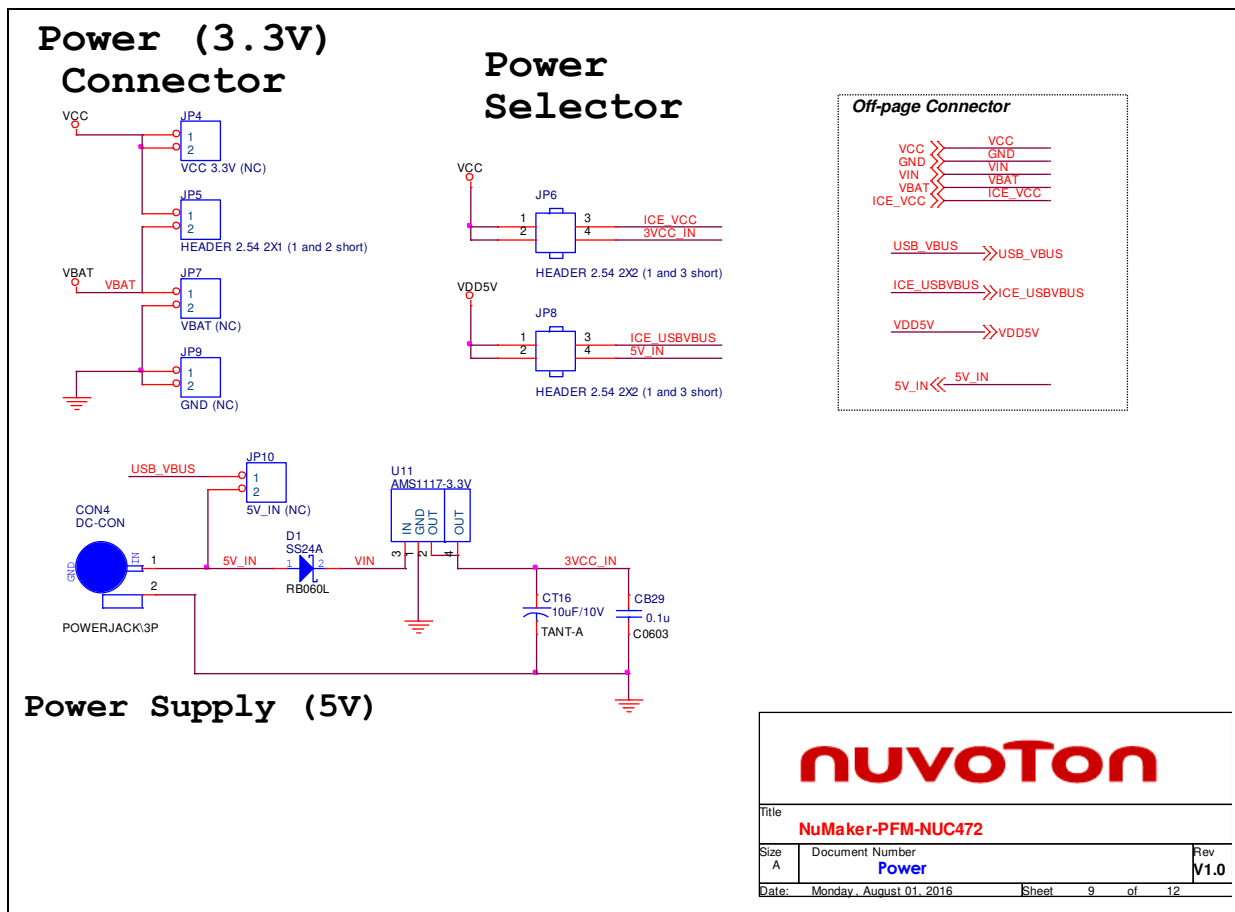

Figure 4-3 Power Circuit and Configurations

4.4 Arduino UNO Compatible Interface

Figure 4-4 shows the Arduino UNO compatible interface of NU1~5 connectors.

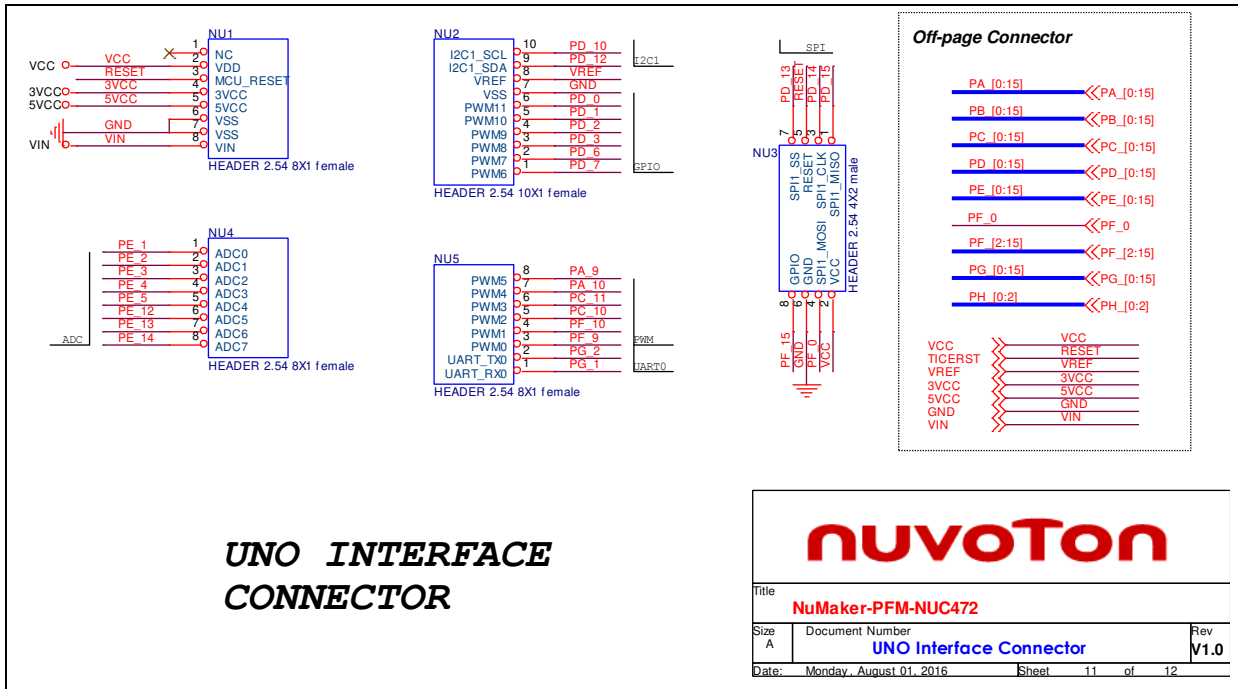

Figure 4-4 Arduino UNO Compatible Interface

4.5 Reset

Figure 4-5 shows the reset circuit for the NUC472 series MCU.

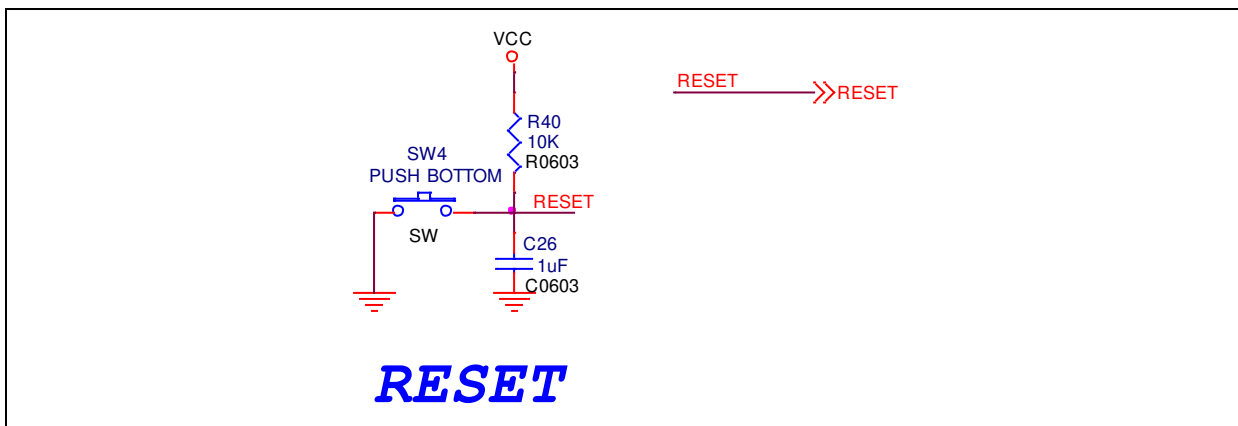

Figure 4-5 Reset Circuit

4.6 Crystal

Figure 4-6 shows two external crystal circuits for the NUC472 series MCU.

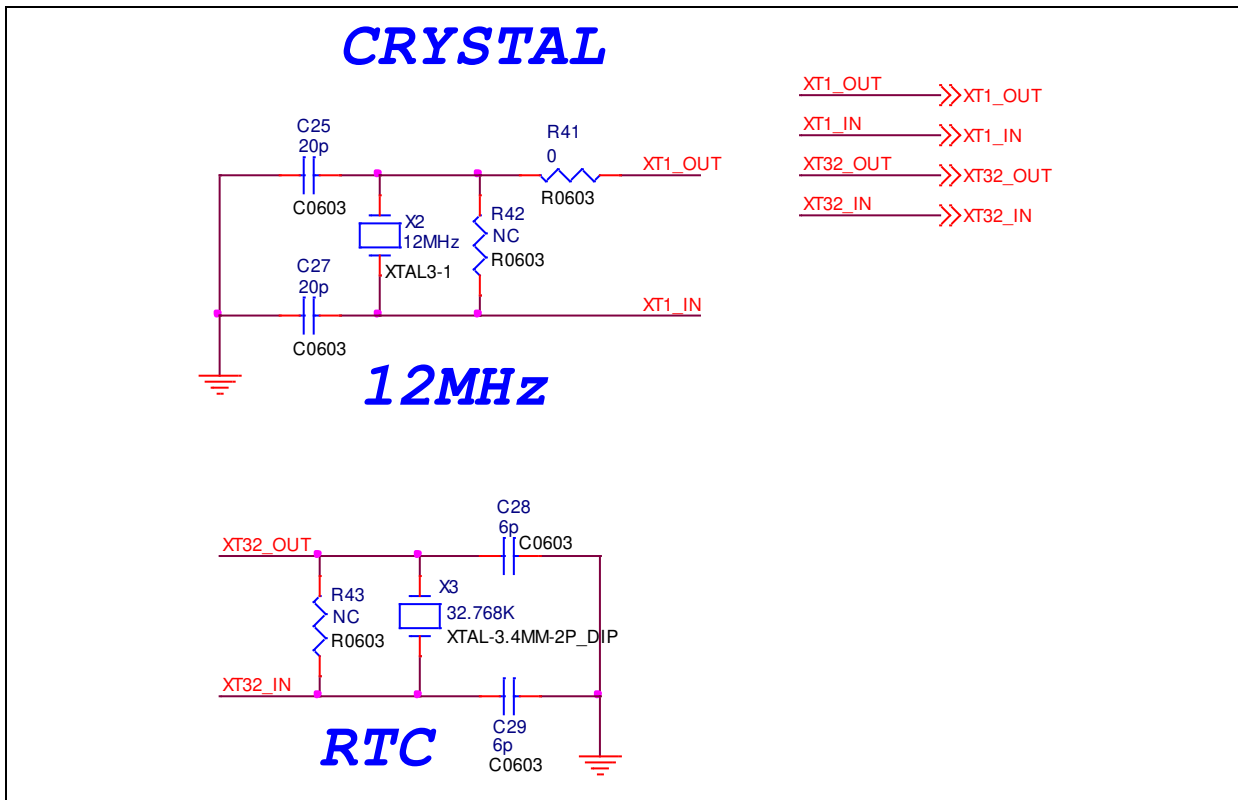

Figure 4-6 External Crystal Circuit

4.7 Battery

Figure 4-7 shows the battery circuit for the NUC472 series MCU.

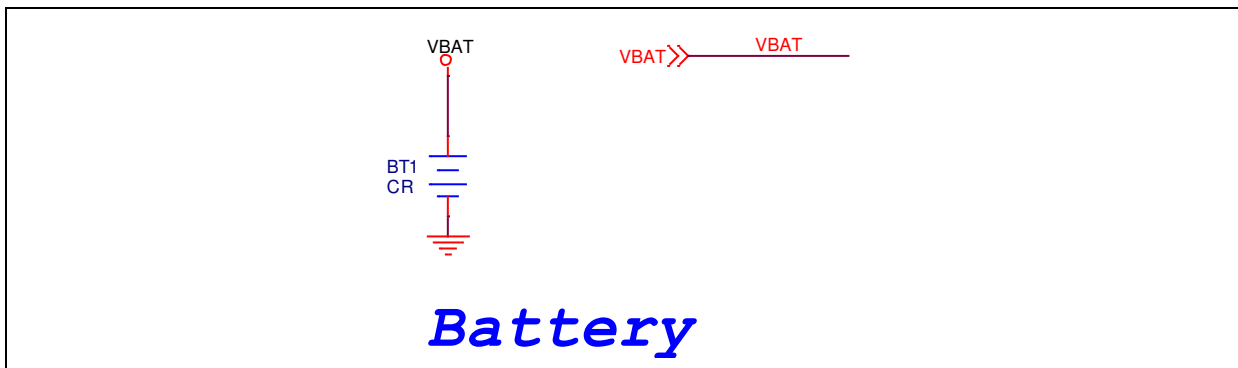

Figure 4-7 Battery Circuit

4.8 LED

Figure 4-8 shows the power LED and an IO LED that be controlled by GPIO PG.0 pin of the NUC472 series MCU.

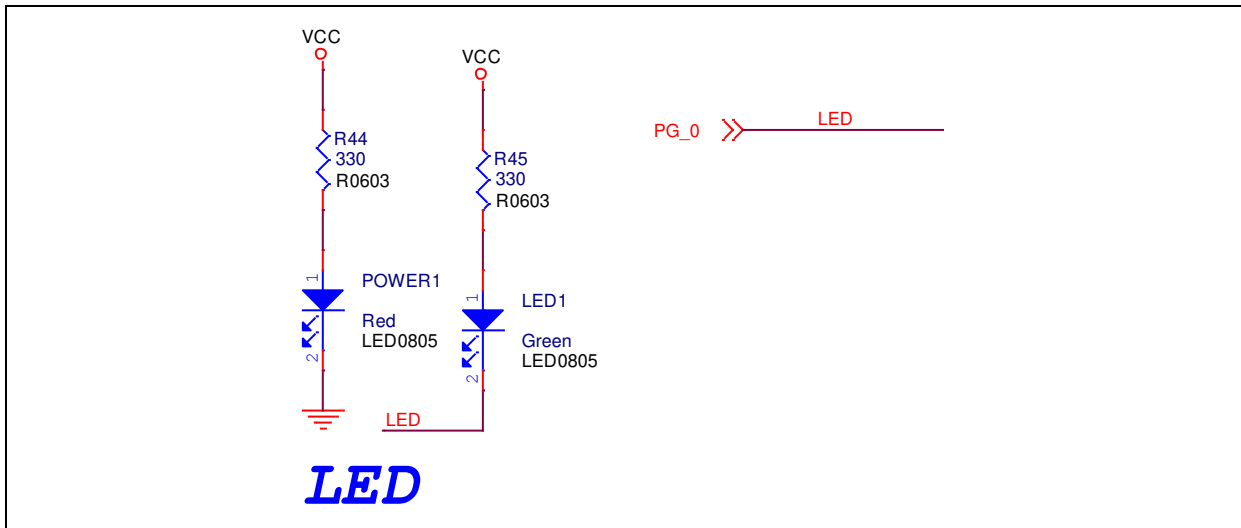

Figure 4-8 Power LED and IO LED Circuit

4.9 RGB LED

Figure 4-9 shows the RGB LED circuit for the NUC472 series MCU.

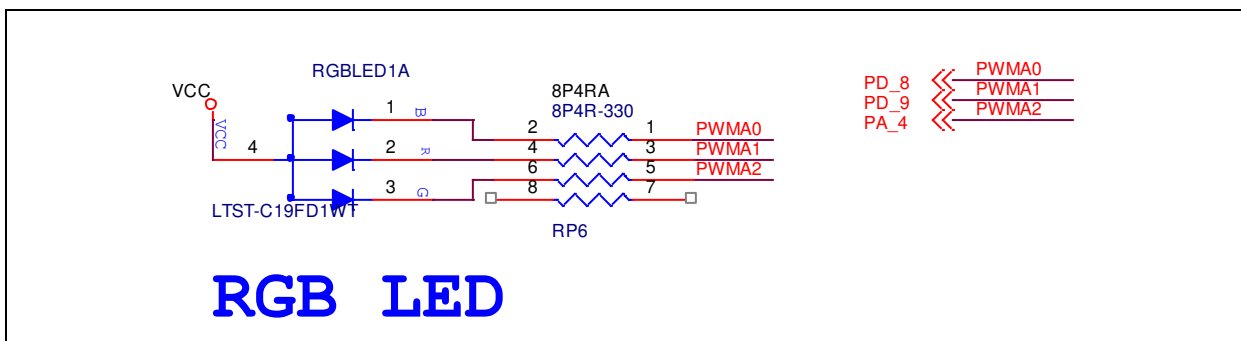

Figure 4-9 RGB LED Circuit

4.10 Push Buttons

Figure 4-10 shows the push buttons circuit for the NUC472 series MCU.

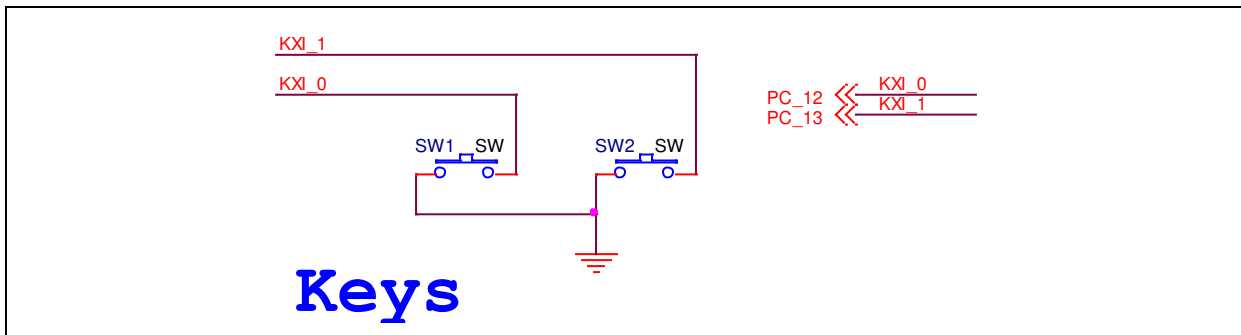

Figure 4-10 Push Buttons Circuit

4.11 Buzzer

Figure 4-11 shows the buzzer circuit for the NUC472 series MCU.

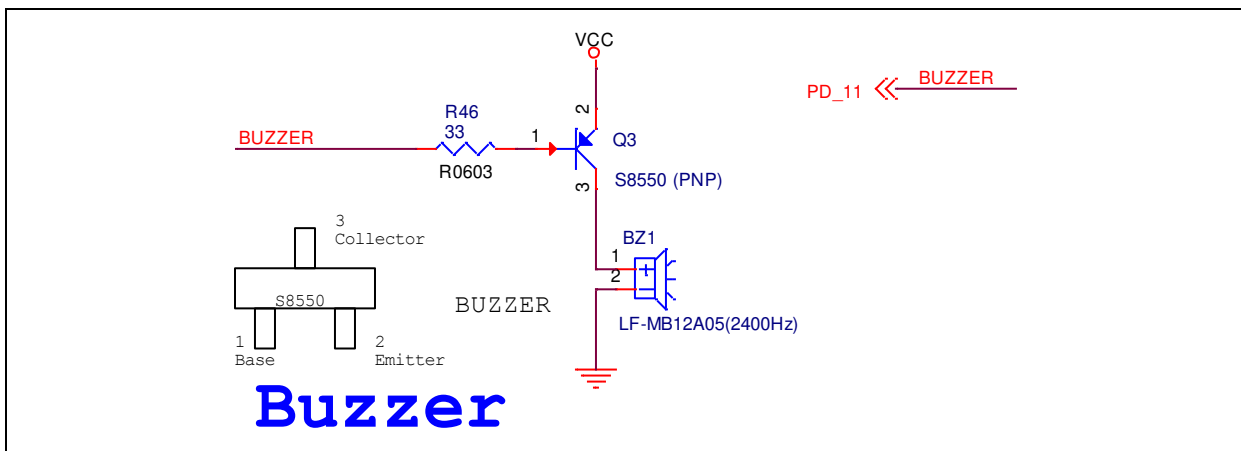

Figure 4-11 Buzzer Circuit

4.12 RS232

Figure 4-12 shows the RS232 circuit for the NUC472 series MCU.

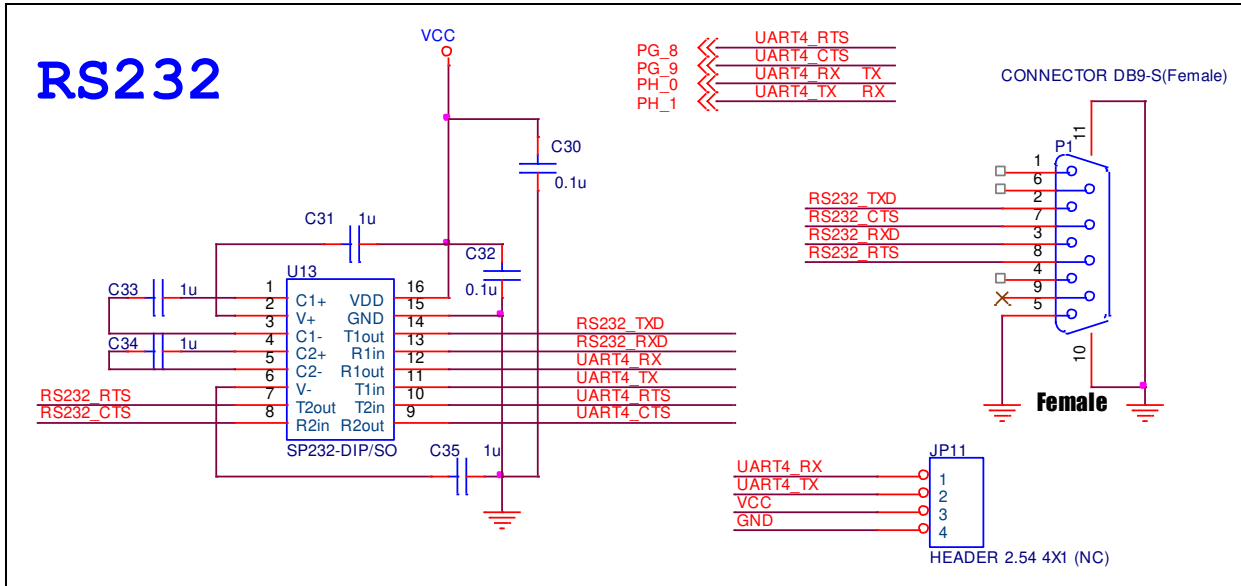

Figure 4-12 RS232 Circuit

4.13 MicroSD Card

Figure 4-13 shows the MicroSD Card circuit for the NUC472 series MCU.

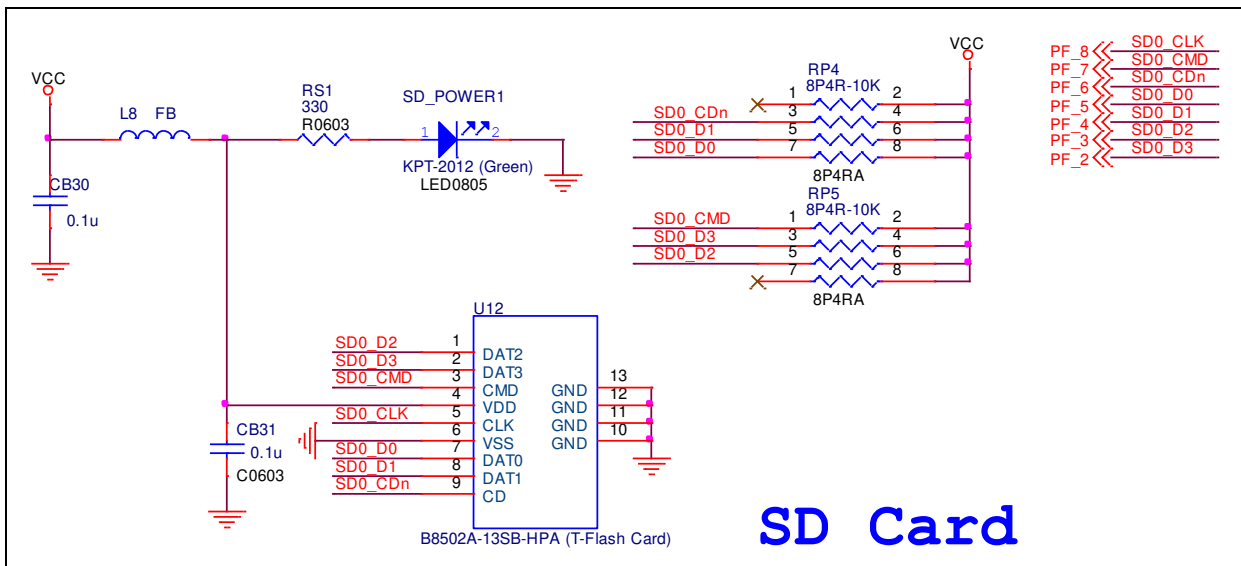

Figure 4-13 MicroSD Card Circuit

4.14 USB OTG and Host

Figure 4-14 shows the USB OTG and Host circuits for the NUC472 series MCU.

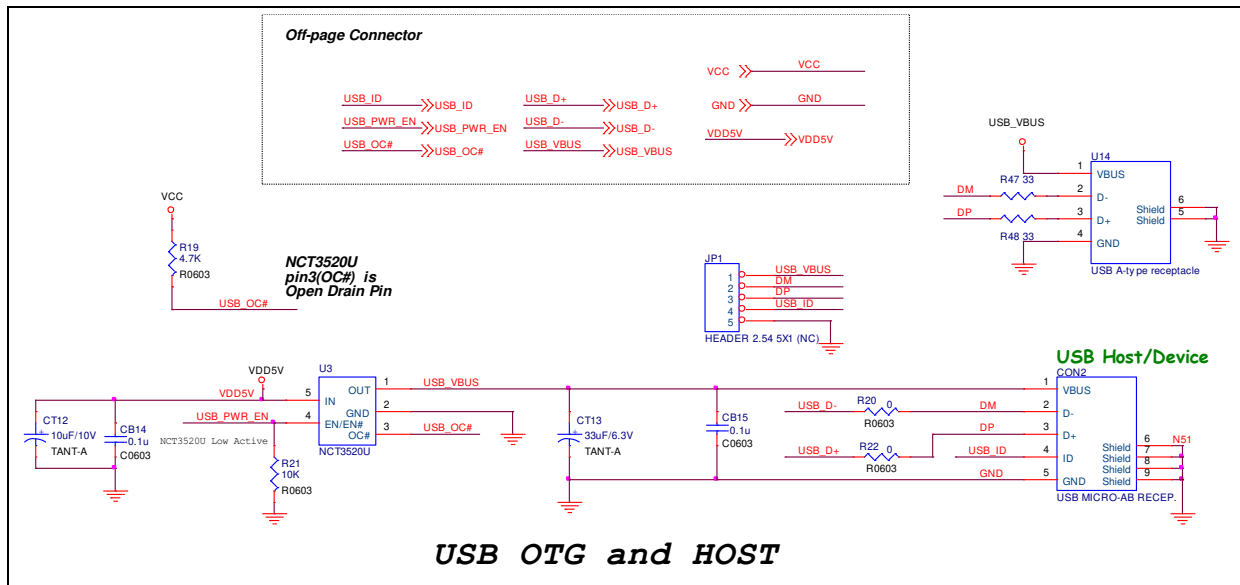

Figure 4-14 USB OTG and Host Circuit

4.15 Ethernet

Figure 4-15 shows the Ethernet interface for networking application of the NUC472 series MCU.

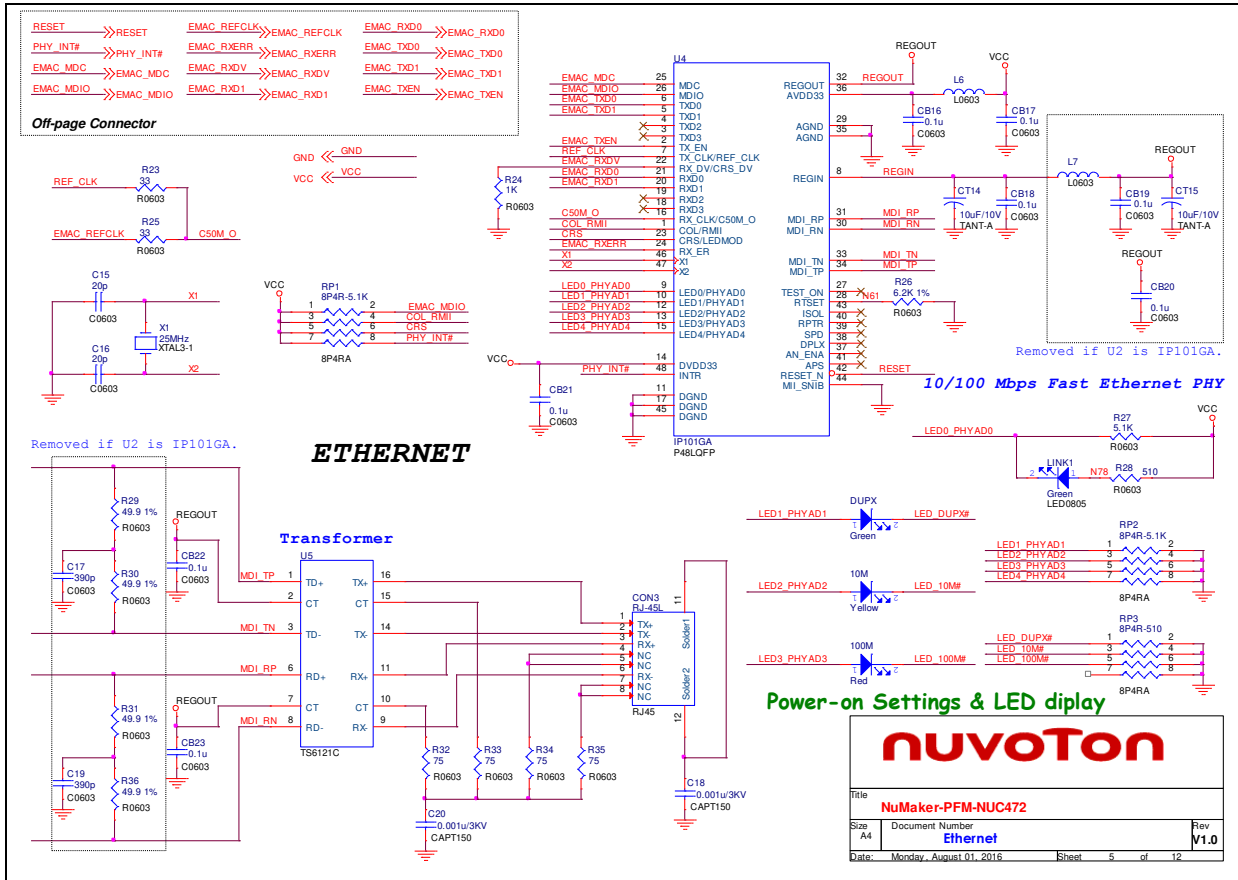

Figure 4-15 Ethernet Circuit

4.16 RS-485

Figure 4-16 shows the RS-485 interface circuit and connectors for the NUC472 series MCU.

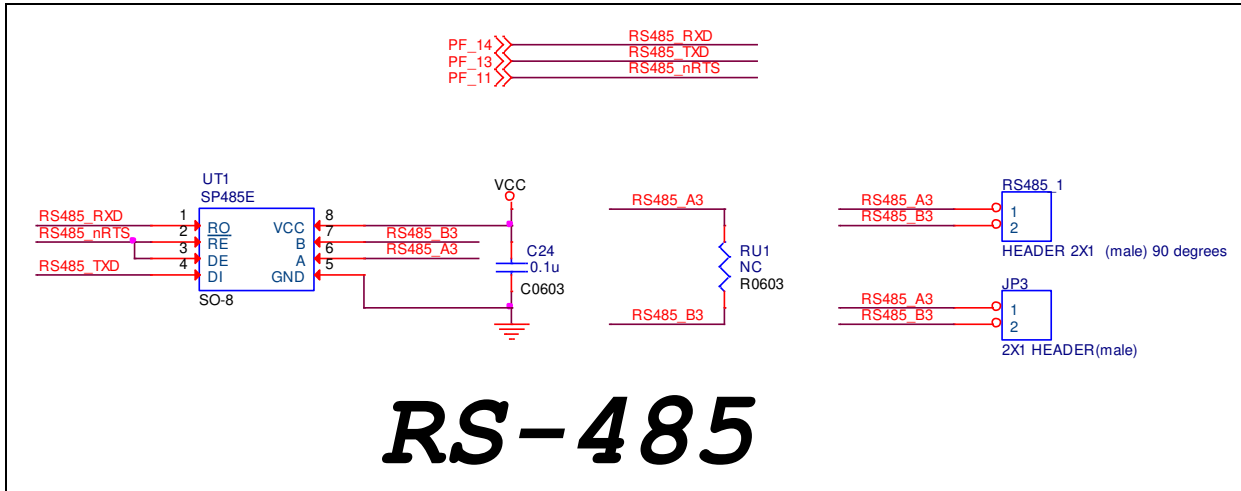

Figure 4-16 RS-485 Circuit and Connectors

4.17 CAN

Figure 4-17 shows the CAN interface circuit and connectors for the NUC472 series MCU.

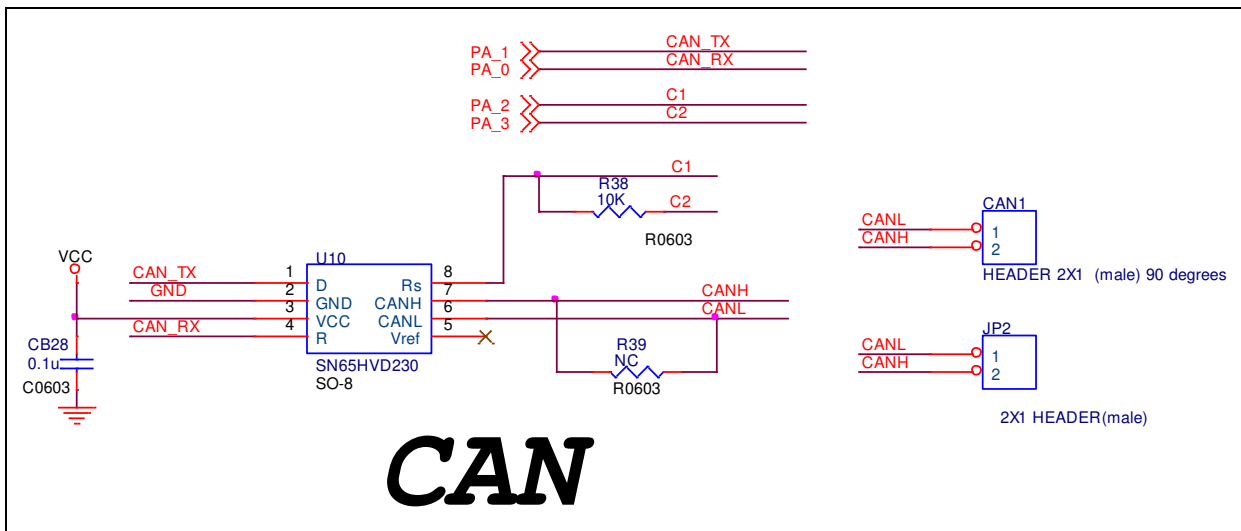

Figure 4-17 CAN Circuit and Connectors

4.18 24-bit Stereo Audio Codec

Figure 4-18 shows the audio codec application circuit based on NAU8822L to simplify implementation of complete audio system solutions.

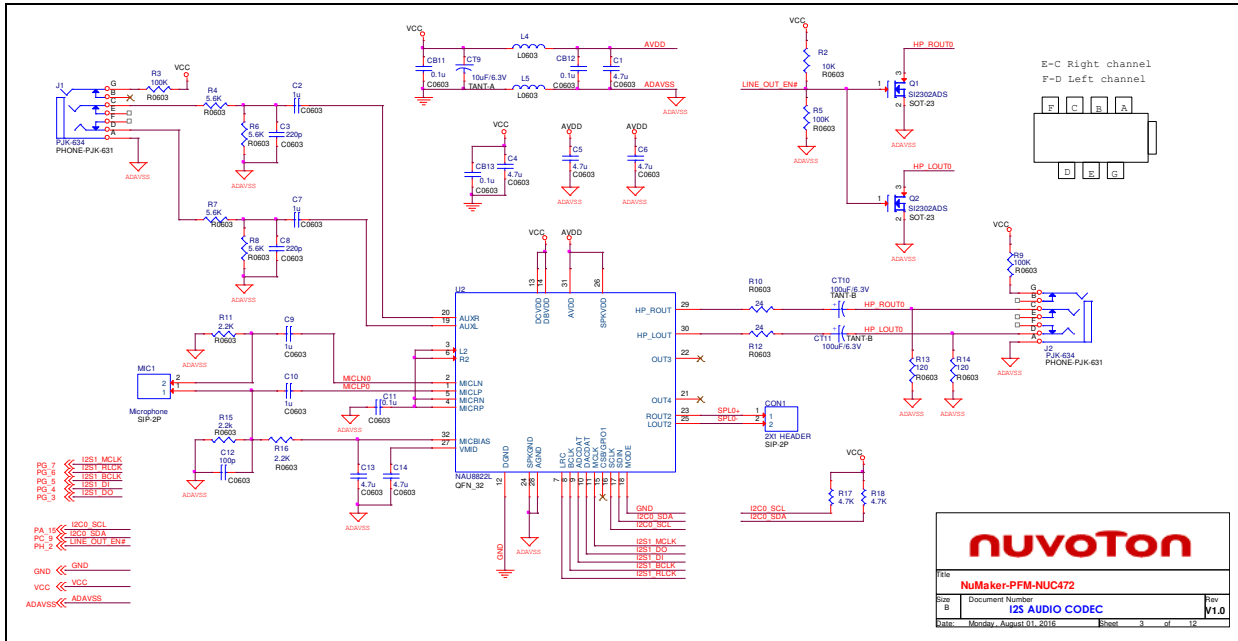

Figure 4-18 Audio Codec Circuit

4.19 SRAM

Figure 4-19 shows the external SRAM memory circuit for the NUC472 series MCU.

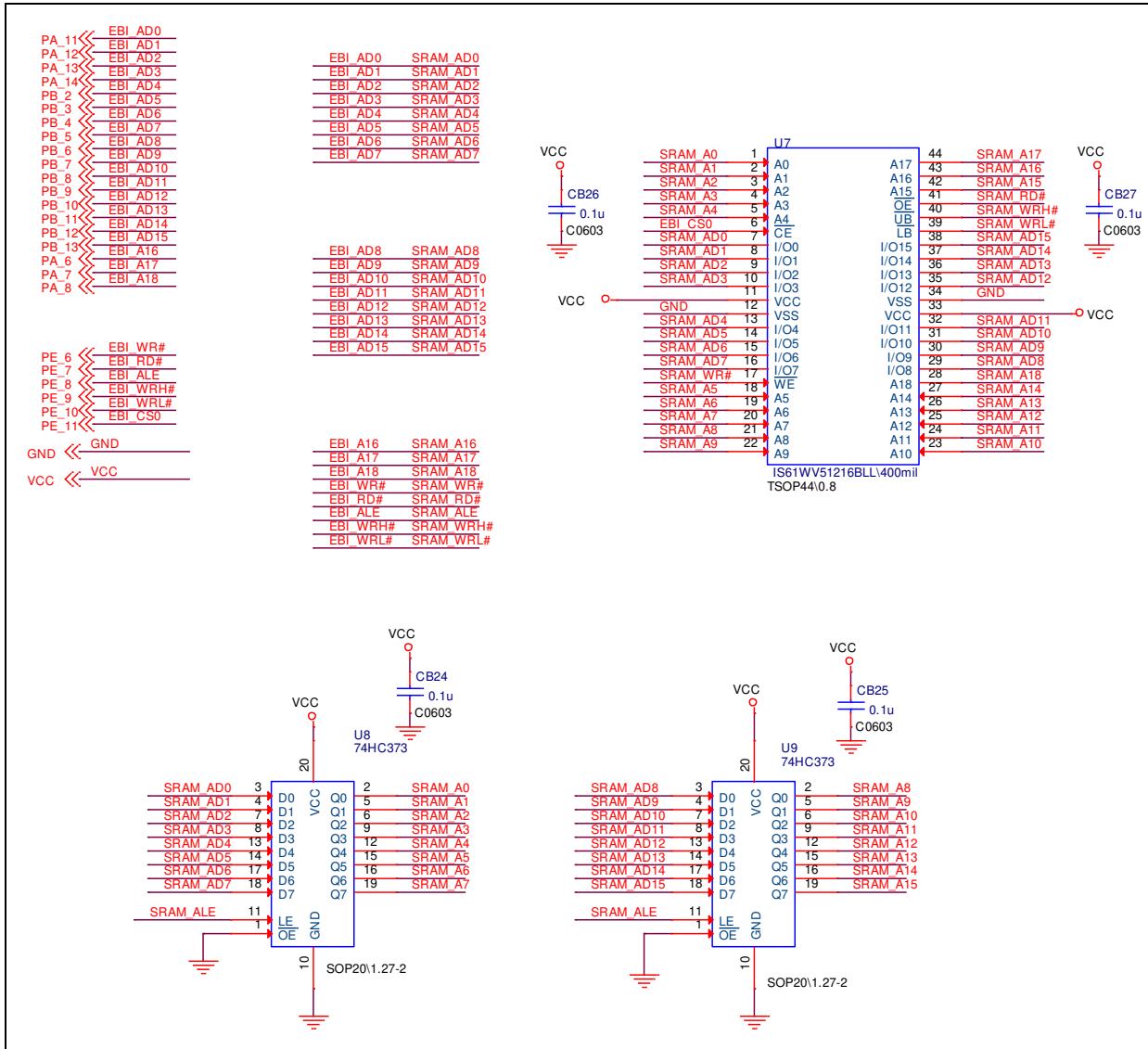

Figure 4-19 External SRAM Memory Circuit

4.20 MPU6500

Figure 4-20 shows the MPU6500 (3-axis Accelerometer and 3-axis Gyroscope) circuit for the NUC472 series MCU.

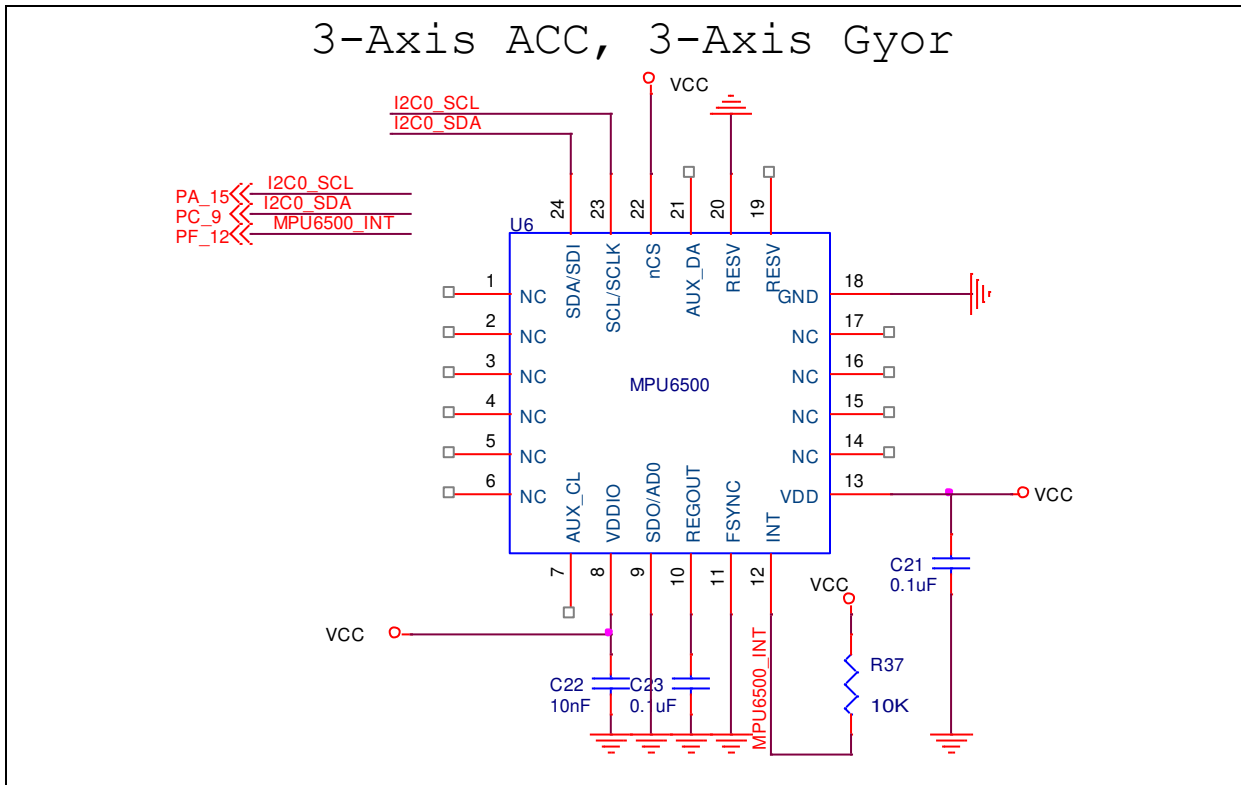

Figure 4-20 MPU6500 Circuit

5 REVISION HISTORY

Date	Revision	Description
2016.06.17	1.00	1. Initially issued.

Important Notice

Nuvoton Products are neither intended nor warranted for usage in systems or equipment, any malfunction or failure of which may cause loss of human life, bodily injury or severe property damage. Such applications are deemed, “Insecure Usage”.

Insecure usage includes, but is not limited to: equipment for surgical implementation, atomic energy control instruments, airplane or spaceship instruments, the control or operation of dynamic, brake or safety systems designed for vehicular use, traffic signal instruments, all types of safety devices, and other applications intended to support or sustain life.

All Insecure Usage shall be made at customer’s risk, and in the event that third parties lay claims to Nuvoton as a result of customer’s Insecure Usage, customer shall indemnify the damages and liabilities thus incurred by Nuvoton.

*Please note that all data and specifications are subject to change without notice.
All the trademarks of products and companies mentioned in this datasheet belong to their respective owners.*