

Mechanical Dimensions: Inches [mm]

Tolerances ± 0.012 [0.3] Unless Otherwise Specified

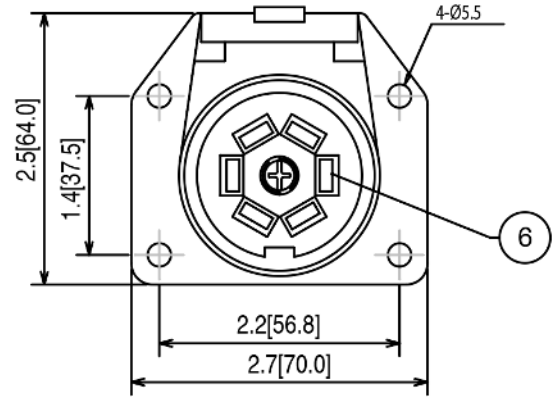
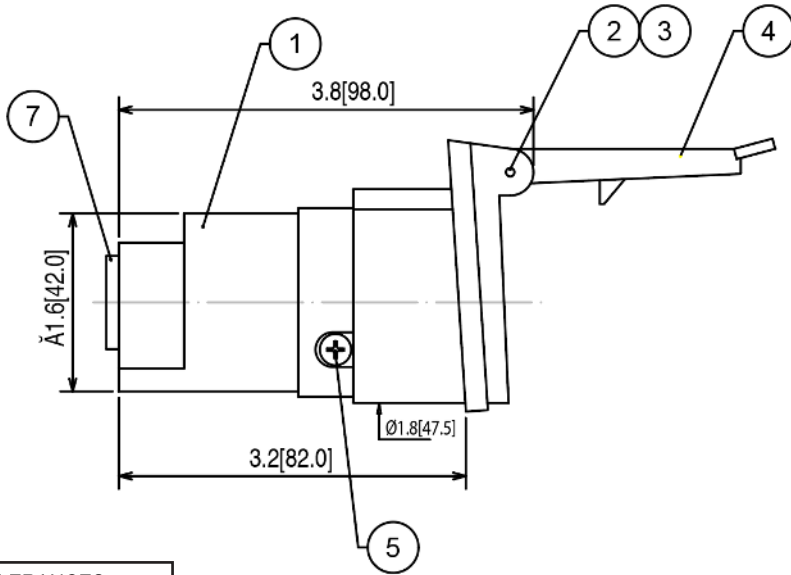

TOLERANCES:
 1mm~5mm:±0.1
 6mm~20mm:±0.2
 21mm~50mm:±0.3
 51mm~100mm:±0.5
ANGLES:±1°

Wiring Color Codes

A.T.A & S.A.E WIRING CODES RECOMMENDED STANDARD

CIRCUITS	POLE WIRING COLOR CODE	RECOMMENDED WIRE GAUGE
Ground Return	White	10 GA
Electric Brake	Blue	12 GA
Tail, License and Running Lights	Green	14 GA
Battery Charge	Black	10 GA
Stop & Left Hand Turn Signal	Red	14 GA
Stop & Right Hand Turn Signal	Brown	14 GA
Auxiliary Circuit	Yellow	14 GA

Material Specifications

ITEM#	NAME	MATERIAL
1	SOCKET SHELL	ABS
2	HINGE PIN	IRON
3	SPRING	STAINLESS STEEL
4	COVER	ABS
5	SET SCREW	IRON
6	7-WAY TERMINAL	BRASS
7	WIRE BOOT	PVC

Rev	Date of issue	Revision Notes	Designed	Approved
A	07-16-2019	Initial Drawing	RC	OH