

Description

The 9SQL4952/9SQL4954/9SQL4958 devices comprise a family of 3.3V PCIe Gen1–5 clock generators with UPI support. There are 2, 4 and 8 outputs versions available and each differential output has a dedicated OE# pin supporting PCIe CLKREQ# functionality.

PCIe Clocking Architectures

- Common Clocked (CC)
- Independent Reference (IR) with and without spread spectrum (SRIS, SRNS)

Typical Applications

- Servers/High-Performance Computing
- nVME Storage
- Networking
- Accelerators
- Industrial Control

Key Specifications

- 90fs RMS typical jitter (PCIe Gen5 CC)
- 70fs RMS typical jitter (QPI ≤ 11.4Gb/s, 12UI)
- < 50ps cycle-to-cycle jitter on differential outputs
- < 50ps output-to-output skew on differential outputs
- ±0ppm synthesis error on differential outputs

Features

- Integrated terminations for 85Ω systems save 4 resistors per output
- 112–206 mW typical power consumption (at 3.3V)
- V_{DDIO} rail allows 35% power savings at optional 1.05V (9SQL4958 only)
- Devices contain default configuration; SMBus not required
- SMBus features allow optimization to application:
 - Input polarity and pull-up/pull-downs
 - Output slew rate and amplitude
 - Output impedance (33Ω, 85Ω or 100Ω)
- Contact factory for customized default configurations
- 25MHz input frequency
- OE# pins support PCIe CLKREQ# function
- Pin-selectable SRnS 0%, CC 0% and CC/SRIS -0.5% spread
- SMBus-selectable CC/SRIS -0.25% spread
- Clean switching between the CC/SRIS spread settings
- BCLK outputs blocked until PLL is locked for clean system startup
- 2 selectable SMBus addresses
- Space-saving packages: See [Ordering Information](#) for details

Output Features

- 2, 4 or 8 100MHz CPU/PCIe output pairs
- One 3.3V LVCMOS REF output with Wake-On-LAN (WOL) support
- See [AN-891](#) for easy AC-coupling to other logic families

Block Diagram

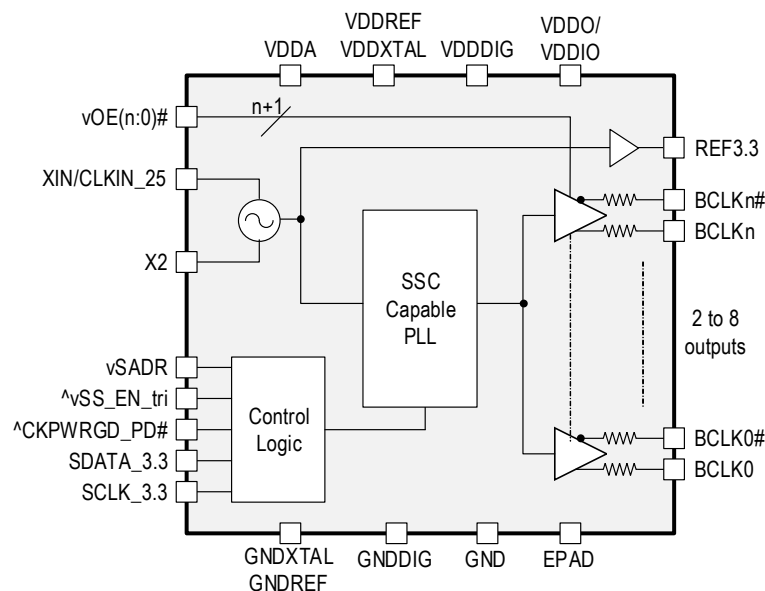

Contents

Description	1
PCIe Clocking Architectures	1
Typical Applications	1
Key Specifications	1
Features	1
Output Features	1
Block Diagram	1
Pin Assignments	3
9SQL4952 Pin Assignment	3
9SQL4954 Pin Assignment	4
9SQL4958 Pin Assignment	5
Pin Descriptions	5
Absolute Maximum Ratings	8
Thermal Characteristics	8
Electrical Characteristics	9
Power Management	15
Test Loads	15
Alternate Terminations	16
Crystal Characteristics	17
General SMBus Serial Interface Information	18
How to Write	18
How to Read	18
Package Outline Drawings	27
Marking Diagrams	27
9SQL4952	27
9SQL4954	27
9SQL4958	27
Ordering Information	28
Revision History	29

Pin Assignments

9SQL4952 Pin Assignment

Figure 1. Pin Assignments for 4 x 4 mm 24-VFQFPN Package – Top View

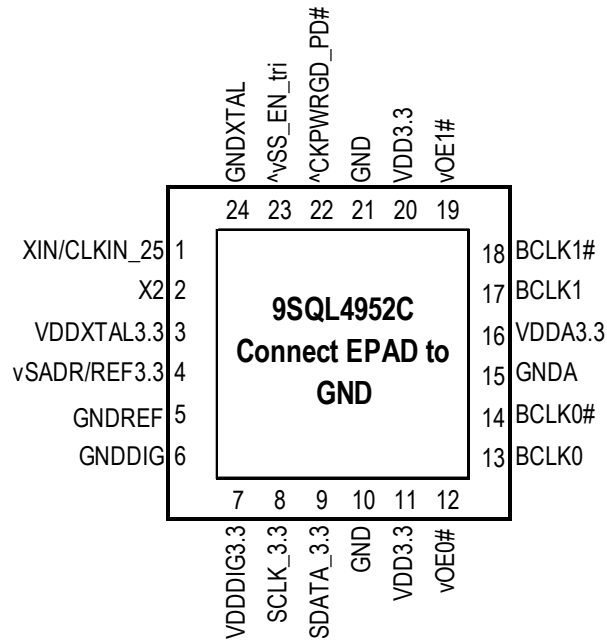

24-VFQFPN, 4 x 4 mm, 0.5mm pitch

^ prefix indicates internal 120kOhm pull-up resistor
 v prefix indicates internal 120kOhm pull-down resistor

9SQL4954 Pin Assignment

Figure 2. Pin Assignments for 5 × 5 mm 32-VFQFPN Package – Top View

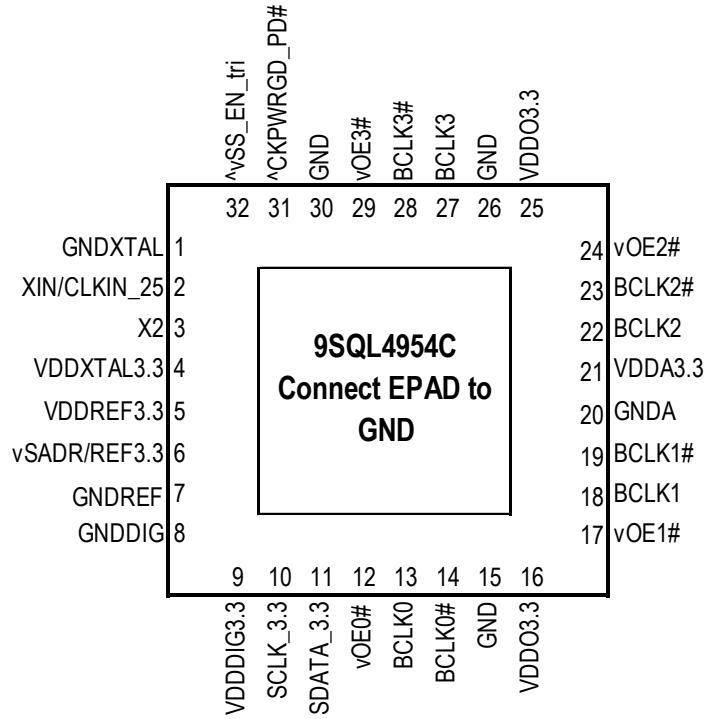

32-VFQFPN, 5 x 5 mm, 0.5mm pitch

^ prefix indicates internal 120kOhm pull-up resistor
 v prefix indicates internal 120kOhm pull-down resistor

9SQL4958 Pin Assignment

Figure 3. Pin Assignments for 6 x 6 mm 48-VFQFPN Package – Top View

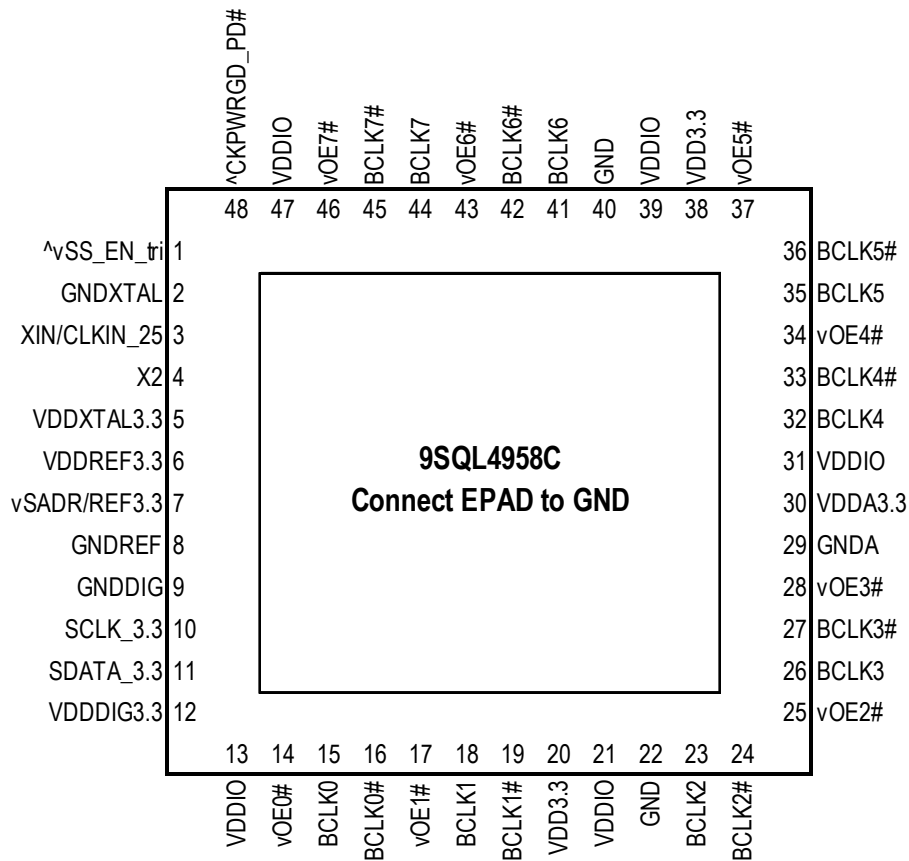

48-VFQFPN, 6 x 6 mm, 0.4mm pitch

^v prefix indicates internal 60kOhm pull-down resistor

v prefix indicates internal 120kOhm pull-down resistor

^ prefix indicates internal 120kOhm pull-up resistor

Pin Descriptions

Table 1. Pin Descriptions

Name	Type	Description	9SQL4958 Pin No.	9SQL4954 Pin No.	9SQL4952 Pin No.
^CKPWRGD_PD#	Input	Input notifies device to sample latched inputs and start up on first high assertion. Low enters Power Down Mode, subsequent high assertions exit Power Down Mode. This pin has internal pull-up resistor.	48	31	22
^vSS_EN_tri	Latched In	Latched select input to select spread spectrum amount at initial power up. See Spread Selection table.	1	32	23
BCLK0	Output	True output of differential BCLK.	15	13	13
BCLK0#	Output	Complement output of differential BCLK.	16	14	14
BCLK1	Output	True output of differential BCLK.	18	18	17
BCLK1#	Output	Complement output of differential BCLK.	19	19	18

Table 1. Pin Descriptions (Cont.)

Name	Type	Description	9SQL4958 Pin No.	9SQL4954 Pin No.	9SQL4952 Pin No.
BCLK2	Output	True output of differential BCLK.	23	22	—
BCLK2#	Output	Complement output of differential BCLK.	24	23	—
BCLK3	Output	True output of differential BCLK.	26	27	—
BCLK3#	Output	Complement output of differential BCLK.	27	28	—
BCLK4	Output	True output of differential BCLK.	32	—	—
BCLK4#	Output	Complement output of differential BCLK.	33	—	—
BCLK5	Output	True output of differential BCLK.	35	—	—
BCLK5#	Output	Complement output of differential BCLK.	36	—	—
BCLK6	Output	True output of differential BCLK.	41	—	—
BCLK6#	Output	Complement output of differential BCLK.	42	—	—
BCLK7	Output	True output of differential BCLK.	44	—	—
BCLK7#	Output	Complement output of differential BCLK.	45	—	—
EPAD	GND	Connect to ground.	49	33	25
GND	GND	Ground pin.	22	15	10
GND	GND	Ground pin.	40	26, 30	21
GND A	GND	Ground pin for the PLL core.	29	20	15
GND DIG	GND	Ground pin for digital circuitry.	9	8	6
GND REF	GND	Ground pin for the REF outputs.	8	7	5
GND XTAL	GND	GND for XTAL.	2	1	24
SCLK_3.3	Input	Clock pin of SMBus circuitry, 3.3V tolerant.	10	10	8
SDATA_3.3	I/O	Data pin for SMBus circuitry, 3.3V tolerant.	11	11	9
VDD3.3	Power	Power supply, nominally 3.3V.	20	16	11
VDD3.3	Power	Power supply, nominally 3.3V.	38	25	20
VDDA3.3	Power	3.3V power for the PLL core.	30	21	16
VDD DIG3.3	Power	3.3V digital power (dirty power).	12	9	7
VDD IO	Power	Power supply for differential outputs.	13	—	—
VDD IO	Power	Power supply for differential outputs.	21	—	—
VDD IO	Power	Power supply for differential outputs.	31	—	—
VDD IO	Power	Power supply for differential outputs.	39	—	—
VDD IO	Power	Power supply for differential outputs.	47	—	—
VDD REF3.3	Power	Power supply for REF output, nominally 3.3V.	6	5	—
VDD XTAL3.3	Power	Power supply for XTAL, nominally 3.3V.	5	4	3
vOE0#	Input	Active low input for enabling output 0. This pin has an internal pull-down. 1 = disable output, 0 = enable output.	14	12	12

Table 1. Pin Descriptions (Cont.)

Name	Type	Description	9SQL4958 Pin No.	9SQL4954 Pin No.	9SQL4952 Pin No.
vOE1#	Input	Active low input for enabling output 1. This pin has an internal pull-down. 1 = disable output, 0 = enable output.	17	17	19
vOE2#	Input	Active low input for enabling output 2. This pin has an internal pull-down. 1 = disable output, 0 = enable output.	25	24	—
vOE3#	Input	Active low input for enabling output 3. This pin has an internal pull-down. 1 = disable output, 0 = enable output.	28	29	—
vOE4#	Input	Active low input for enabling output 4. This pin has an internal pull-down. 1 = disable output, 0 = enable output.	34	—	—
vOE5#	Input	Active low input for enabling output 5. This pin has an internal pull-down. 1 = disable output, 0 = enable output.	37	—	—
vOE6#	Input	Active low input for enabling output 6. This pin has an internal pull-down. 1 = disable output, 0 = enable output.	43	—	—
vOE7#	Input	Active low input for enabling output 7. This pin has an internal pull-down. 1 = disable output, 0 = enable output.	46	—	—
vSADR/REF3.3	Latched I/O	Latch to select SMBus Address/3.3V LVCMOS copy of X1/REFIN pin	7	6	4
X2	Output	Crystal output.	4	3	2
XIN/CLKIN_25	Input	Crystal input or Reference Clock input. nominally 25MHz.	3	2	1

Table 2. Spread Selection

\wedge vSS_EN_tri Pin	B1[4:3]	Spread%	Note
0	00	0	PCIe SRnS mode.
—	01	-0.25	PCIe Common Clock or SRIS mode.
M (VDD/2)	10	0	PCIe Common Clock or SRIS mode.
1	11	-0.50	PCIe Common Clock or SRIS mode.

If SRnS mode is desired, power up with \wedge vSS_EN_tri = '0'. Do not attempt to switch to the other modes via SMBus control in Byte 1 or a system reset will be required. If Common Clock (CC) or SRIS mode is desired, power up with \wedge vSS_EN_tri at either 'M' or '1'. The desired spread spectrum amount can then be selected via Byte 1 without a requiring a system reset. Once 'M' or '1' is latched at power up, do not attempt to enter SRnS mode or a system reset will be required.

Absolute Maximum Ratings

The absolute maximum ratings are stress ratings only. Stresses greater than those listed below can cause permanent damage to the device. Functional operation of the 9SQL4952/9SQL4954/9SQL4958 at absolute maximum ratings is not implied. Exposure to absolute maximum rating conditions may affect device reliability.

Table 3. Absolute Maximum Ratings

Parameter	Symbol	Conditions	Minimum	Maximum	Units	Notes
Supply Voltage	V_{DDx}		-0.5	4.6	V	1,2
Input Voltage	V_{IN}		-0.5	$V_{DD} + 0.5$	V	1,3
Input High Voltage, SMBus	V_{IHSMB}	SMBus clock and data pins.		3.9	V	1
Storage Temperature	T_s		-65	150	°C	1
Junction Temperature	T_j			125	°C	1
Input ESD Protection	ESD prot	Human Body Model.	2500		V	1

¹ Guaranteed by design and characterization, not 100% tested in production.

² Operation under these conditions is neither implied nor guaranteed.

³ Not to exceed 4.6V.

Thermal Characteristics

Table 4. Thermal Characteristics

Parameter	Symbol	Conditions	Package	Typical Values	Units	Notes
9SQL4952 Thermal Resistance	θ_{JC}	Junction to case.	NLG24	62	°C/W	1
	θ_{Jb}	Junction to base.		5.4	°C/W	1
	θ_{JA0}	Junction to air, still air.		50	°C/W	1
	θ_{JA1}	Junction to air, 1 m/s air flow.		43	°C/W	1
	θ_{JA3}	Junction to air, 3 m/s air flow.		39	°C/W	1
	θ_{JA5}	Junction to air, 5 m/s air flow.		38	°C/W	1
9SQL4954 Thermal Resistance	θ_{JC}	Junction to case.	NLG32	42	°C/W	1
	θ_{Jb}	Junction to base.		2.4	°C/W	1
	θ_{JA0}	Junction to air, still air.		39	°C/W	1
	θ_{JA1}	Junction to air, 1 m/s air flow.		33	°C/W	1
	θ_{JA3}	Junction to air, 3 m/s air flow.		28	°C/W	1
	θ_{JA5}	Junction to air, 5 m/s air flow.		27	°C/W	1
9SQL4958 Thermal Resistance	θ_{JC}	Junction to case.	NDG48	33	°C/W	1
	θ_{Jb}	Junction to base.		2.1	°C/W	1
	θ_{JA0}	Junction to air, still air.		37	°C/W	1
	θ_{JA1}	Junction to air, 1 m/s air flow.		30	°C/W	1
	θ_{JA3}	Junction to air, 3 m/s air flow.		27	°C/W	1
	θ_{JA5}	Junction to air, 5 m/s air flow.		26	°C/W	1

¹ EPAD soldered to board.

Electrical Characteristics

$T_A = T_{AMB}$. Supply voltages per normal operation conditions; see [Test Loads](#) for loading conditions.

Table 5. SMBus Parameters

Parameter	Symbol	Conditions	Minimum	Typical	Maximum	Units	Notes
SMBus Input Low Voltage	V_{ILSMB}	$V_{DDSMB} = 3.3V$.			0.8	V	
SMBus Input High Voltage	V_{IHSMB}	$V_{DDSMB} = 3.3V$.	2.1		3.6	V	
SMBus Output Low Voltage	V_{OLSMB}	At I_{PULLUP} .			0.4	V	
SMBus Sink Current	I_{PULLUP}	At V_{OL} .	4			mA	
Nominal Bus Voltage	V_{DDSMB}		2.7		3.6	V	
SCLK/SDATA Rise Time	t_{RSMB}	(Max. $V_{IL} - 0.15V$) to (Min. $V_{IH} + 0.15V$).			1000	ns	1
SCLK/SDATA Fall Time	t_{FSMB}	(Min. $V_{IH} + 0.15V$) to (Max. $V_{IL} - 0.15V$).			300	ns	1
SMBus Operating Frequency	f_{SMB}	SMBus operating frequency.			500	kHz	2

¹ Guaranteed by design and characterization, not 100% tested in production.

² The device must be powered up for the SMBus to function.

Table 6. Input/Supply/Common Parameters – Normal Operating Conditions

Parameter	Symbol	Conditions	Minimum	Typical	Maximum	Units	Notes
Supply Voltage	V_{DDxxx}	Supply voltage for core, analog and single-ended LVCMOS outputs.	3.135	3.3	3.465	V	
IO Supply Voltage	V_{DDIO}	Supply voltage for differential low power outputs.	0.9975	1.05–3.3	3.465	V	
Ambient Operating Temperature	T_{AMB}	Industrial range.	-40	25	85	°C	
Input High Voltage	V_{IH}	Single-ended inputs, except SMBus.	$0.75 \times V_{DDx}$		$V_{DDx} + 0.3$	V	
Input Low Voltage	V_{IL}		-0.3		$0.25 \times V_{DDx}$	V	
Input High Voltage	V_{IHtri}	Single-ended tri-level inputs ('_tri' suffix).	$0.8 \times V_{DDx}$		$V_{DDx} + 0.3$	V	
Input Mid Voltage	V_{IMtri}		$0.4 \times V_{DDx}$	$0.5 \times V_{DDx}$	$0.6 \times V_{DDx}$	V	
Input Low Voltage	V_{ILtri}		-0.3		$0.20 \times V_{DDx}$	V	
Input Current	I_{IN}	Single-ended inputs, $V_{IN} = GND$, $V_{IN} = V_{DD}$.	-5	-0.05	5	μA	
	I_{INP}	Single-ended inputs. $V_{IN} = 0V$; inputs with internal pull-up resistors. $V_{IN} = V_{DD}$; inputs with internal pull-down resistors.	-50	7	50	μA	
Input Frequency	F_{IN}	XTAL or X1 input.		25		MHz	4
Pin Inductance	L_{pin}				7	nH	1
Capacitance	C_{IN}	Logic inputs, except DIF_IN.	1.5		5	pF	1
	C_{OUT}	Output pin capacitance.			6	pF	1
CLK Stabilization	t_{STAB}	From V_{DD} power-up and after input clock stabilization or deassertion of PD# to 1st clock.		0.3	1.8	ms	1,2

Table 6. Input/Supply/Common Parameters – Normal Operating Conditions (Cont.)

Parameter	Symbol	Conditions	Minimum	Typical	Maximum	Units	Notes
SS Modulation Frequency	f_{MOD}	Triangular modulation.	30	31.6	33	kHz	1
OE# Latency	$t_{LATO\#}$	DIF start after OE# assertion. DIF stop after OE# deassertion.	1	2	3	clocks	1,3
Tdrive_PD#	t_{DRVPD}	DIF output enable after PD# de-assertion.			300	μ s	1,3
Fall Time	t_F	Fall time of single-ended control inputs.			5	ns	1,2
Rise Time	t_R	Rise time of single-ended control inputs.			5	ns	1,2

¹ Guaranteed by design and characterization, not 100% tested in production.

² Control input must be monotonic from 20% to 80% of input swing.

³ Time from deassertion until outputs are > 200mV.

⁴ Contact the factory for other frequencies.

Table 7. BCLK Low-Power HCSL Outputs

Parameter	Symbol	Conditions	Minimum	Typical	Maximum	Units	Notes
Slew Rate	Trf	Scope averaging on, fast setting.	2	2.7	4	V/ns	2,3
		Scope averaging, slow setting.	1	1.9	3	V/ns	2,3
Crossing Voltage (abs)	Vcross_abs	Scope averaging off.	250	409	550	mV	1,4,5
Crossing Voltage (var)	Δ -Vcross	Scope averaging off.		14	140	mV	1,4,9
Avg. Clock Period Accuracy	T _{PERIOD_AVG}	Devices have 0 ppm synthesis error. The maximum occurs with -0.5% SSC.	0	0	+2500	ppm	2,10,12,13
Absolute Period	T _{PERIOD_ABS}	Includes jitter and spread spectrum modulation.	9.95	10	10.0503	ns	2,6
Jitter, Cycle to Cycle	$t_{j\text{cyc-cyc}}$			16	50	ps	2
Voltage High	V _{HIGH}	Statistical measurement on single-ended signal using oscilloscope math function (scope averaging on).	660	761	850	mV	1
Voltage Low	V _{LOW}		-150	-7	150	mV	1
Absolute Maximum Voltage	V _{MIN}	Measurement on single-ended signal using absolute value (scope averaging off).		819	1150	mV	1,7,15
Absolute Minimum Voltage	V _{MAX}		-300	-46			1,8,15
Duty Cycle	t_{DC}		45	49	55	%	2
Slew Rate Matching	Δ Trf	Single-ended measurement.		6	20	%	1,14
Skew, Output to Output	t_{sk3}	Averaging on, V _T = 50%.		12	50	ps	2

¹ Measured from single-ended waveform.

² Measured from differential waveform.

³ Measured from -150 mV to +150 mV on the differential waveform (derived from REFCLK+ minus REFCLK-). The signal must be monotonic through the measurement region for rise and fall time. The 300mV measurement window is centered on the differential zero crossing.

⁴ Measured at crossing point where the instantaneous voltage value of the rising edge of REFCLK+ equals the falling edge of REFCLK-.

- ⁵ Refers to the total variation from the lowest crossing point to the highest, regardless of which edge is crossing. Refers to all crossing points for this measurement.
- ⁶ Defines as the absolute minimum or maximum instantaneous period. This includes cycle to cycle jitter, relative ppm tolerance, and spread spectrum modulation.
- ⁷ Defined as the maximum instantaneous voltage including overshoot.
- ⁸ Defined as the minimum instantaneous voltage including undershoot.
- ⁹ Defined as the total variation of all crossing voltages of Rising REFCLK+ and Falling REFCLK-. This is the maximum allowed variance in V_{CROSS} for any particular system.
- ¹⁰ Refer to Section 8.6.2 of the PCI Express Base Specification, Revision 5.0 for information regarding PPM considerations.
- ¹¹ System board compliance measurements must use the test load. REFCLK+ and REFCLK- are to be measured at the load capacitors C_L . Single-ended probes must be used for measurements requiring single ended measurements. Either single-ended probes with math or differential probe can be used for differential measurements. Test load $C_L = 2\text{pF}$.
- ¹² PCIe Gen1 through Gen4 specify $\pm 300\text{ppm}$ frequency tolerances. PCIe Gen5 reduces the allowable tolerance to $\pm 100\text{ppm}$ without spread spectrum.
- ¹³ "ppm" refers to parts per million and is a DC absolute period accuracy specification. 1ppm is 1/1,000,000th of 100.000000MHz exactly or 100Hz. For 100ppm, then we have an error budget of $100\text{Hz/ppm} \times 100\text{ppm} = 10\text{kHz}$. The period is to be measured with a frequency counter with measurement window set to 100ms or greater. The $\pm 100\text{ppm}$ applies to systems that do not employ Spread Spectrum clocking, or that use common clock source. For systems employing Spread Spectrum clocking, there is an additional 2,500ppm nominal shift in maximum period resulting from the 0.5% down spread resulting in a maximum average period specification of +2,600ppm for Common Clock architectures. Separate Reference Clock architectures may have a lower allowed spread percentage.
- ¹⁴ Matching applies to rising edge rate for REFCLK+ and falling edge rate for REFCLK-. It is measured using a $\pm 75\text{ mV}$ window centered on the median cross point where REFCLK+ rising meets REFCLK- falling. The median cross point is used to calculate the voltage thresholds the oscilloscope is to use for the edge rate calculations. The Rise Edge Rate of REFCLK+ should be compared to the Fall Edge Rate of REFCLK-; the maximum allowed difference should not exceed 20% of the slowest edge rate.
- ¹⁵ At default SMBus amplitude settings.

Table 8. UPI Phase Jitter of Differential Outputs

Parameter	Symbol	Conditions	Minimum	Typical	Maximum	Specification Limits	Units	Notes
Phase Jitter, ZDB Mode	t_{jphQPI_UPI}	QPI and UPI (100MHz, 8.0Gb/s, 12UI)		0.08	0.12	0.3	ps (RMS)	1,2
		QPI and UPI (100MHz, $\leq 11.4\text{Gb/s}$, 12UI)		0.07	0.10	0.2	ps (RMS)	1,2

¹ Applies to all differential outputs, guaranteed by design and characterization. See [Test Loads](#) for measurement setup details.

² Calculated from Intel™-supplied Clock Jitter Tool. Equipment noise removed from the results.

Table 9. 12kHz–20MHz Phase Jitter of Differential Outputs

Parameter	Symbol	Conditions	Minimum	Typical	Maximum	Units
Phase Jitter, 12kHz–20MHz	$t_{jph12k20M}$	Differential outputs when device is set to PCIe SRnS mode (Byte1[4:3] = 00).		1.9	2	ps (rms)

Table 10. Current Consumption – 9SQL4952

Parameter	Symbol	Conditions	Minimum	Typical	Maximum	Units	Notes
Operating Supply Current	I _{DDAOP}	V _{DDA} , all outputs active at 100MHz.		13	17	mA	
	I _{DDOP}	All V _{DD} , except V _{DDA} , all outputs active at 100MHz.		18	23	mA	
Wake-on-LAN Current (Power down state and Byte 3, bit 5 = '1')	I _{DDAPD}	V _{DDA} , DIF outputs off, REF output running.		0.9	1.5	mA	1
	I _{DDPD}	All V _{DD} , except V _{DDA} , DIF outputs off, REF output running.		5.7	8	mA	1
Power Down Current (Power down state and Byte 3, bit 5 = '0')	I _{DDAPD}	V _{DDA} , all outputs off.		0.9	1.5	mA	
	I _{DDPD}	All V _{DD} , except V _{DDA} , all outputs off.		1.7	2.5	mA	

¹ This is the current required to have the REF output running in Wake-on-LAN mode (Byte 3, bit 5 = 1).

Table 11. Current Consumption – 9SQL4954

Parameter	Symbol	Conditions	Minimum	Typical	Maximum	Units	Notes
Operating Supply Current	I _{DDAOP}	V _{DDA} , all outputs active at 100MHz.		13	17	mA	
	I _{DDOP}	All other V _{DD} , except V _{DDA} , all outputs active at 100MHz.		30	39	mA	
Wake-on-LAN Current (Power down state and Byte 3, bit 5 = '1')	I _{DDAPD}	V _{DDA} , DIF outputs off, REF output running.		0.9	1.5	mA	1
	I _{DDPD}	All other V _{DD} , except V _{DDA} , DIF outputs off, REF output running.		5.9	8.0	mA	1
Power Down Current (Power down state and Byte 3, bit 5 = '0')	I _{DDAPD}	V _{DDA} , all outputs off.		0.9	1.5	mA	
	I _{DDPD}	All other V _{DD} , except V _{DDA} , all outputs off.		1.5	2.5	mA	

¹ This is the current required to have the REF output running in Wake-on-LAN mode (Byte 3, bit 5 = 1).

Table 12. Current Consumption – 9SQL4958

Parameter	Symbol	Conditions	Minimum	Typical	Maximum	Units	Notes
Operating Supply Current	I _{DDAOP}	V _{DDA} , all outputs active at 100MHz.		14	19	mA	
	I _{DDOP}	All V _{DD} , except V _{DDA} and V _{DDIO} , all outputs active at 100MHz.		18	24	mA	
	I _{DDIOOP}	V _{DDIO} , all outputs active at 100MHz.		30	37	mA	
Wake-on-LAN Current (Power down state and Byte 3, bit 5 = '1')	I _{DDAPD}	V _{DDA} , DIF outputs off, REF output running.		0.9	1.5	mA	1
	I _{DDPD}	All V _{DD} , except V _{DDA} and V _{DDIO} , DIF outputs off, REF output running.		5.2	8	mA	1
	I _{DDIOOP}	V _{DDIO} , DIF outputs off, REF output running.		0.04	0.1	mA	1
Power Down Current (Power down state and Byte 3, bit 5 = '0')	I _{DDAPD}	V _{DDA} , all outputs off.		0.9	1.5	mA	
	I _{DDPD}	All V _{DD} , except V _{DDA} and V _{DDIO} , all outputs off.		1.7	2.3	mA	
	I _{DDIOOP}	V _{DDIO} , all outputs off.		0.04	0.1	mA	

¹ This is the current required to have the REF output running in Wake-on-LAN mode (Byte 3, bit 5 = 1).

Table 13. PCIe Phase Jitter of Differential Outputs

T_{AMB} = over the specified operating range. Supply voltages per normal operation conditions. See [Test Loads](#) for loading conditions.

Parameter	Symbol	Conditions	Minimum	Typical	Maximum	Limit	Units	Notes
PCIe Phase Jitter (Common Clocked Architecture)	t _{jph} PCIeG1-CC	PCIe Gen1 (2.5 GT/s)		18	28	86	ps (p-p)	1,2,7
	t _{jph} PCIeG2-CC	PCIe Gen2 Hi Band (5.0 GT/s)		0.9	1.6	3	ps (RMS)	1,2,7
		PCIe Gen2 Lo Band (5.0 GT/s)		0.4	0.6	3.1	ps (RMS)	1,2,
	t _{jph} PCIeG3-CC	PCIe Gen3 (8.0 GT/s)		0.25	0.4	1	ps (RMS)	1,2,3,7
	t _{jph} PCIeG4-CC	PCIe Gen4 (16.0 GT/s)		0.25	0.4	0.5	ps (RMS)	1,2,3,4,7
	t _{jph} PCIeG5-CC	PCIe Gen5 (32.0 GT/s)		0.09	0.11	0.15	ps (RMS)	1,2,3,5,7
PCIe Phase Jitter (SRIS Architecture)	t _{jph} PCIeG1-SRIS	PCIe Gen1 (2.5 GT/s)		4	6	N/A	ps (RMS)	1,2,6,8
	t _{jph} PCIeG2-SRIS	PCIe Gen2 (5.0 GT/s)		0.8	1.1		ps (RMS)	1,2,6,8
	t _{jph} PCIeG3-SRIS	PCIe Gen3 (8.0 GT/s)		0.3	0.4		ps (RMS)	1,2,6,8
	t _{jph} PCIeG4-SRIS	PCIe Gen4 (16.0 GT/s)		0.3	0.35		ps (RMS)	1,2,6,8
	t _{jph} PCIeG5-SRIS	PCIe Gen5 (32.0 GT/s)		0.15	0.19		ps (RMS)	1,2,6,8

¹ The REFCLK jitter is measured after applying the filter functions found in PCI Express Base Specification 5.0, Revision 1.0. See the [Test Loads](#) section of the data sheet for the exact measurement setup. Values for the Common Clock architecture are calculated for CC/SRIS spread off and spread on at -0.5%. SRIS values are calculated for CC/SRIS spread off and spread on at ≤-0.3%. If oscilloscope data is used, equipment noise is removed from all results.

² Jitter measurements shall be made with a capture of at least 100,000 clock cycles captured by a real-time oscilloscope (RTO) with a sample rate of 20 GS/s or greater. Broadband oscilloscope noise must be minimized in the measurement. The measured PP jitter is used (no extrapolation) for RTO measurements. Alternately, jitter measurements may be used with a Phase Noise Analyzer (PNA) extending (flat) and integrating and folding the frequency content up to an offset from the carrier frequency of at least 200MHz (at 300MHz absolute frequency) below the Nyquist frequency. For PNA measurements for the 2.5 GT/s data rate, the RMS jitter is converted to peak to peak jitter using a multiplication factor of 8.83. In the case where real-time oscilloscope and PNA measurements have both been done and produce different results, the RTO result must be used.

³ SSC spurs from the fundamental and harmonics are removed up to a cutoff frequency of 2MHz taking care to minimize removal of any non-SSC content.

⁴ Note that 0.7ps RMS is to be used in channel simulations to account for additional noise in a real system.

⁵ Note that 0.25ps RMS is to be used in channel simulations to account for additional noise in a real system.

⁶ While the PCI Express Base Specification 5.0, Revision 1.0 provides the filters necessary to calculate SRIS jitter values, it does not provide specification limits, hence the N/A in the "Limit" column. SRIS values are informative only. In general, a clock operating in an SRIS system must be twice as good as a clock operating in a Common Clock system. For RMS values, twice as good is equivalent to dividing the CC value by √2. An additional consideration is the value for which to divide by √2. The conservative approach is to divide the ref clock jitter limit, and the case can be made for dividing the channel simulation values by √2, if the ref clock is close to the Tx clock input. An example for Gen4 is as follows. A "rule-of-thumb" SRIS limit would be either 0.5ps RMS/√2 = 0.35ps RMS, or 0.7ps RMS/√2 = 0.5ps RMS.

⁷ Calculated for Byte1[4:3] spread settings of 01, 10 and 11.

⁸ Calculated for Byte1[4:3] spread settings of 01, and 10.

Table 14. REF Output

Parameter	Symbol	Conditions	Minimum	Typical	Maximum	Units	Notes
Long Accuracy	ppm	See Tperiod min-max values.	0			ppm	1,2
Clock Period	T _{period}	REF output.	40			ns	2
High Output Voltage	V _{HIGH}	I _{OH} = -2mA.	0.8 x V _{DDREF}			V	
Low Output Voltage	V _{LOW}	I _{OL} = 2mA.			0.2 x V _{DDREF}	V	
Rise/Fall Slew Rate	t _{rf1}	Byte 3 = 1F, V _{OH} = 0.8 x V _{DD} , V _{OL} = 0.2 x V _{DD} .	0.5	0.9	1.5	V/ns	1
	t _{rf1}	Byte 3 = 5F, V _{OH} = 0.8 x V _{DD} , V _{OL} = 0.2 x V _{DD} .	1.0	1.5	2.5	V/ns	1,3
	t _{rf1}	Byte 3 = 9F, V _{OH} = 0.8 x V _{DD} , V _{OL} = 0.2 x V _{DD} .	1.5	2.1	3.1	V/ns	1
	t _{rf1}	Byte 3 = DF, V _{OH} = 0.8 x V _{DD} , V _{OL} = 0.2 x V _{DD} .	2.0	2.7	3.8	V/ns	1
Duty Cycle	d _{t1X}	V _T = V _{DD} /2 V.	45	49.7	55	%	1,4
Jitter, Cycle to Cycle	t _{j_{cyc-cyc}}	V _T = V _{DD} /2 V.		35	125	ps	1,4
Noise Floor	t _{dBc1k}	1kHz offset.		-145	-135	dBc	1,4
	t _{dBc10k}	10kHz offset to Nyquist.		-150	-140	dBc	1,4
Jitter, Phase	t _{j_{phREF}}	12kHz to 5MHz, DIF SSC off.		0.13	0.3	ps (rms)	1,4
		12kHz to 5MHz, DIF SSC on.		1.4	1.5	ps (rms)	1,4

¹ Guaranteed by design and characterization, not 100% tested in production.

² All Long Term Accuracy and Clock Period specifications are guaranteed assuming that REF is trimmed to 25.00MHz.

³ Default SMBus value.

⁴ When driven by a crystal.

Power Management

Table 15. Power Management ³

CKPWRGD_PD#	SMBus OE bit	OEx# Pin	Differential Output		REF
			True O/P	Comp. O/P	
0	X	X	Low ¹	Low ¹	Hi-Z ²
1	1	0	Running	Running	Running
1	1	1	Disabled ¹	Disabled ¹	Running
1	0	X	Disabled ¹	Disabled ¹	Disabled ⁴

¹ The output state is set by B11[1:0] (Low/Low default).

² REF is Hi-Z until the 1st assertion of CKPWRGD_PD# high. After this, when CKPWRGD_PD# is low, REF is disabled unless Byte3[5] = 1, in which case REF is running.

³ Input polarities defined at default values.

⁴ See SMBus description for Byte 3, bit 4.

Table 16. SMBus Address Selection

	SADR	Address	+ Read/Write Bit
State of SADR on first application of CKPWRGD_PD#	0	1101000	X
	1	1101010	X

Test Loads

Figure 4. Single-ended Output Test Load

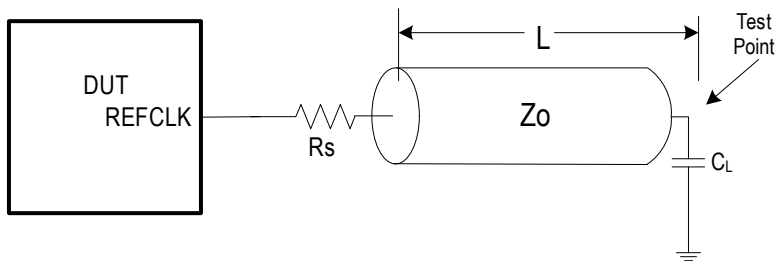

Table 17. Terminations for Single-ended Output

Clock Source	Device Under Test (DUT)	Rs (Ω)	Zo (Ω)	L (cm)	CL (pF)
N/A	9SQL495x	33	50	12.7	4.7

Figure 5. Test Load for AC/DC Measurements

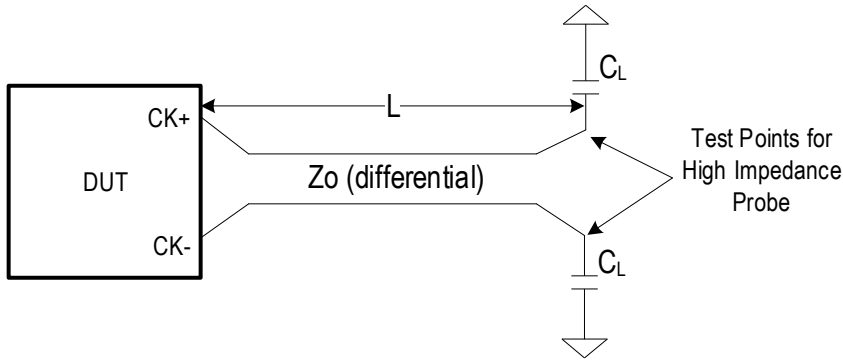

Table 18. Terminations for AC/DC Measurements

Clock Source	Device Under Test (DUT)	Rs (Ω)	Zo (Ω)	L (cm)	CL (pF)
N/A	9SQL495x	Internal	85	12.7	2

Figure 6. Test Setup for PCIe Clock Phase Jitter Measurements

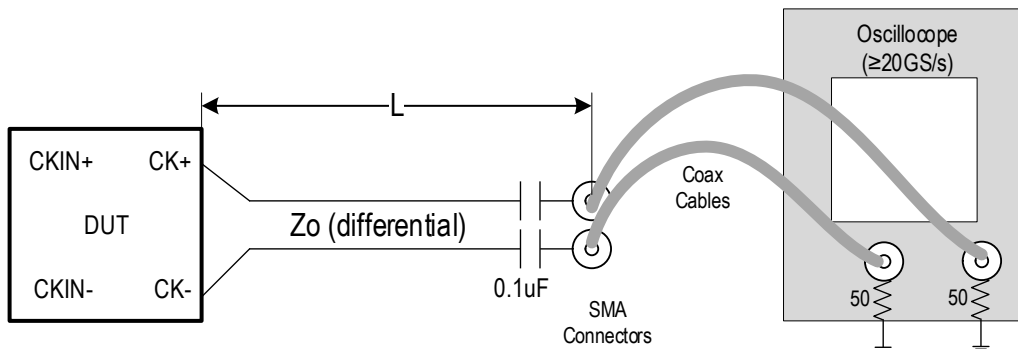

Table 19. Terminations for PCIe Clock Phase Jitter Measurements

Clock Source	Device Under Test (DUT)	Rs (Ω)	Zo (Ω)	L (cm)	CL (pF)
N/A	9SQL495x	Internal	85	12.7	N/A

Alternate Terminations

The device family can easily drive LVPECL, LVDS, and CML logic. See [“AN-891 Driving LVPECL, LVDS, and CML Logic with IDT’s “Universal” Low-Power HCSL Outputs”](#) for details.

Crystal Characteristics

Table 20. Recommended Crystal Characteristics

Parameter	Value	Units
Frequency ¹	25	MHz
Resonance Mode	Fundamental	—
Frequency Tolerance @ 25°C	±20	ppm maximum
Frequency Stability, reference at 25°C over operating temperature range	±20	ppm maximum
Temperature Range (industrial)	-40 to +85	°C
Temperature Range (commercial)	0 to +70	°C
Equivalent Series Resistance (ESR)	50	Ω maximum
Shunt Capacitance (C _O)	7	pF maximum
Load Capacitance (C _L)	8	pF maximum
Drive Level	0.1	mW maximum
Aging per year	±5	ppm maximum

¹ When driven by an external oscillator via the XIN/CLKIN_25 pin, X2 should be floating.

General SMBus Serial Interface Information

How to Write

- Controller (host) sends a start bit
- Controller (host) sends the write address
- IDT clock will **acknowledge**
- Controller (host) sends the beginning byte location = N
- IDT clock will **acknowledge**
- Controller (host) sends the byte count = X
- IDT clock will **acknowledge**
- Controller (host) starts sending Byte N through Byte N+X-1
- IDT clock will **acknowledge** each byte **one at a time**
- Controller (host) sends a stop bit

Index Block Write Operation		
Controller (Host)		IDT (Slave/Receiver)
T	starT bit	
Slave Address		
WR	WRite	
		ACK
Beginning Byte = N		
		ACK
Data Byte Count = X		
		ACK
Beginning Byte N		
		ACK
O	X Byte	O
O		O
O		O
		O
Byte N + X - 1		
		ACK
P	stoP bit	

Note: Address is latched on SADR pin.

How to Read

- Controller (host) will send a start bit
- Controller (host) sends the write address
- IDT clock will **acknowledge**
- Controller (host) sends the beginning byte location = N
- IDT clock will **acknowledge**
- Controller (host) will send a separate start bit
- Controller (host) sends the read address
- IDT clock will **acknowledge**
- IDT clock will send the data byte count = X
- IDT clock sends Byte N+X-1
- IDT clock sends **Byte 0 through Byte X (if X_(H) was written to Byte 8)**
- Controller (host) will need to acknowledge each byte
- Controller (host) will send a not acknowledge bit
- Controller (host) will send a stop bit

Index Block Read Operation		
Controller (Host)		IDT (Slave/Receiver)
T	starT bit	
Slave Address		
WR	WRite	
		ACK
Beginning Byte = N		
		ACK
RT	Repeat starT	
Slave Address		
RD	ReaD	
		ACK
		Data Byte Count=X
ACK		
ACK		Beginning Byte N
O	X Byte	O
O		O
O		O
O		O
		Byte N + X - 1
N	Not acknowledge	
P	stoP bit	

Table 21. Byte 0: Output Enable Register

Byte 0 ¹	Bit7	Bit6	Bit5	Bit4	Bit3	Bit2	Bit1	Bit0
Control Function	Output Enable	Output Enable	Output Enable	Output Enable	Output Enable	Output Enable	Output Enable	Output Enable
Type	RW	RW	RW	RW	RW	RW	RW	RW
0	See B11[1:0]							
1	OE# Pin Controls Output							
9SQL4958 Name	OE7	OE6	OE5	OE4	OE3	OE2	OE1	OE0
9SQL4958 Default	1	1	1	1	1	1	1	1
9SQL4954 Name	Reserved	Reserved	Reserved	Reserved	OE3	OE2	OE1	OE0
9SQL4954 Default	x	x	x	x	1	1	1	1
9SQL4952 Name	Reserved	Reserved	Reserved	Reserved	Reserved	OE1	OE0	Reserved
9SQL4952 Default	x	x	x	x	x	1	1	x

¹ A low on these bits will override the OE# pin and force the differential output to the state indicated by B11[1:0] (Low/Low default)

Table 22. Byte 1: Spread Spectrum with V_{HIGH} Control Register

Byte 1	Bit7	Bit6	Bit5	Bit4	Bit3	Bit2	Bit1	Bit0
Control Function	SS Enable Readback Bit1	SS Enable Readback Bit0	Enable software control of spread spectrum	SS Software Control Bit1	SS Software Control Bit0	Reserved	Controls Output Amplitude	
Type	R	R	RW	RW ¹	RW ¹		RW	RW
0	See Spread Selection table		SS controlled by latch (B1[7:6])	See Spread Selection table			00 = 0.6V	10 = 0.75V
1			Values in B1[4:3] control SS amount				01 = 0.68V	11 = 0.85V
Name	SSENRB1	SSENRB1	SSEN_SWCNTRL	SSENSW1	SSENSW0	AMPLITUDE 1	AMPLITUDE 0	
Default	Latch	Latch	0	0	0	x	1	0

¹ See notes on [Spread Selection](#) table. B1[5] must be set to a 1 in order to use B1[4:3].

Table 23. Byte 2: BCLK Slew Selection Register

Byte 2	Bit7	Bit6	Bit5	Bit4	Bit3	Bit2	Bit1	Bit0
Control Function	Select fast or slow slew rate	Select fast or slow slew rate	Select fast or slow slew rate	Select fast or slow slew rate	Select fast or slow slew rate	Select fast or slow slew rate	Select fast or slow slew rate	Select fast or slow slew rate
Type	RW	RW	RW	RW	RW	RW	RW	RW
0	Slow Slew Rate							
1	Fast Setting							
9SQL4958 Name	BCLK7_slew	BCLK6_slew	BCLK5_slew	BCLK4_slew	BCLK3_slew	BCLK2_slew	BCLK1_slew	BCLK0_slew
9SQL4958 Default	1	1	1	1	1	1	1	1
9SQL4954 Name	Reserved	Reserved	Reserved	Reserved	BCLK3_slew	BCLK2_slew	BCLK1_slew	BCLK0_slew
9SQL4954 Default	x	x	x	x	1	1	1	1
9SQL4952 Name	Reserved	Reserved	Reserved	Reserved	Reserved	BCLK1_slew	BCLK0_slew	Reserved
9SQL4952 Default	x	x	x	x	x	1	1	x

¹ See [BCLK Low-Power HCSL Outputs](#) table for slew rates.

Table 24. Byte 3: REF Slew Rate Control Register

Byte 3	Bit7	Bit6	Bit5	Bit4	Bit3	Bit2	Bit1	Bit0
Control Function	Slew Rate Control		Wake-on-Lan Enable for REF	REF Output Enable	Reserved	Reserved	Reserved	Reserved
Type	RW	RW	RW	RW				
0	00 = Slowest	10 = Fast	REF disabled in Power Down	Disabled ¹				
1	01 = Slow	11 = Fastest	REF runs in Power Down	Enabled				
Name	REF Slew Rate [1:0]		REF Power Down Function	REF OE				
Default	0	1	0	1	x	x	x	x

¹ The disabled state depends on Byte11[1:0]. '00' = Low, '01'= HiZ, '10' = Low, '11' = High.

Byte 4 is Reserved

Table 25. Byte 5: Revision and Vendor ID Register

Byte 5	Bit7	Bit6	Bit5	Bit4	Bit3	Bit2	Bit1	Bit0
Control Function	Revision ID				VENDOR ID			
Type	R	R	R	R	R	R	R	R
0	C rev = 0010				0001 = IDT/Renesas			
1								
Name	RID3	RID2	RID1	RID0	VID3	VID2	VID1	VID0

Table 26. Byte 6: Device Type/Device ID Register

Byte 6	Bit7	Bit6	Bit5	Bit4	Bit3	Bit2	Bit1	Bit0
Control Function	Device Type		Device ID					
Type	R	R	R	R	R	R	R	R
0	00 = 9SQL		9SQL4958 = 0b00100 9SQL4954 = 0b00100 9SQL4952 = 0b00010					
1								
Name	Device Type1	Device Type0	Device ID5	Device ID4	Device ID3	Device ID2	Device ID1	Device ID0

Table 27. Byte 7: Byte Count Register

Byte 7	Bit7	Bit6	Bit5	Bit4	Bit3	Bit2	Bit1	Bit0
Control Function	Reserved	Reserved	Reserved	Byte Count Programming				
Type				RW	RW	RW	RW	RW
0				Writing to this register will configure how many bytes will be read back.				
1								
Name				BC4	BC3	BC2	BC1	BC0
Default	x	x	x	0	1	0	0	0

Bytes 8 and 9 are Reserved

Table 28. Byte 10: PLL MN Enable, PD_Restore Register

Byte 10	Bit7	Bit6	Bit5	Bit4	Bit3	Bit2	Bit1	Bit0
Control Function	M/N Programming Enable	Restore Default Config. In PD	Reserved	Reserved	Reserved	Reserved	Reserved	Reserved
Type	RW	RW						
0	M/N Prog. Disabled	Clear Config in PD						
1	M/N Prog. Enabled	Keep Config in PD						
Name	PLL M/N En	Power-Down (PD) Restore						
Default	0	1	x	x	x	x	x	x

Table 29. Byte 11: Stop State Control Register

Byte 11	Bit7	Bit6	Bit5	Bit4	Bit3	Bit2	Bit1	Bit0
Control Function	Reserved	Reserved	Reserved	Reserved	Reserved	Reserved	True/Complement DIF Output Disable State	
Type							RW	RW
0							00 = Low/Low	01 = HiZ/HiZ
1							10 = High/Low	11 = Low/High
Name							STP[1]	STP[0]
Default	x	x	x	x	x	x	0	0

Table 30. Byte 12: Impedance Control Register 1

Byte 12	Bit7	Bit6	Bit5	Bit4	Bit3	Bit2	Bit1	Bit0
Control Function	Output impedance control [1:0]		Output impedance control [1:0]		Output impedance control [1:0]		Output impedance control [1:0]	
Type	RW	RW	RW	RW	RW	RW	RW	RW
0	00 = 33ohm BCLK Zout, 01 = 85ohm BCLK Zout							
1	10 = 100ohm BCLK Zout, 11 = Reserved							
9SQL4958 Name	BCLK3_imp[1]	BCLK3_imp[0]	BCLK2_imp[1]	BCLK2_imp[0]	BCLK1_imp[1]	BCLK1_imp[0]	BCLK0_imp[1]	BCLK0_imp[0]
9SQL4958 Default	9SQL4958 defaults to 0b01010101							
9SQL4954 Name	BCLK1_imp[1]	BCLK1_imp[0]	Reserved	Reserved	BCLK0_imp[1]	BCLK0_imp[0]	Reserved	Reserved

Table 30. Byte 12: Impedance Control Register 1 (Cont.)

Byte 12	Bit7	Bit6	Bit5	Bit4	Bit3	Bit2	Bit1	Bit0
9SQL4954 Default	9SQL4954 defaults to 0b01xx01xx							
9SQL4952 Name	BCLK0_imp[1]	BCLK0_imp[0]	Reserved	Reserved	Reserved	Reserved	Reserved	Reserved
9SQL4952 Default	9SQL4952 defaults to 0b01xxxxxx							

Table 31. Byte 13: Impedance Control Register 2

Byte 13	Bit7	Bit6	Bit5	Bit4	Bit3	Bit2	Bit1	Bit0
Control Function	Output impedance control [1:0]		Output impedance control [1:0]		Output impedance control [1:0]		Output impedance control [1:0]	
Type	RW	RW	RW	RW	RW	RW	RW	RW
0	00 = 33ohm BCLK Zout, 01 = 85ohm BCLK Zout 10 = 100ohm BCLK Zout, 11 = Reserved							
1								
9SQL4958 Name	BCLK7_imp[1]	BCLK7_imp[0]	BCLK6_imp[1]	BCLK6_imp[0]	BCLK5_imp[1]	BCLK5_imp[0]	BCLK4_imp[1]	BCLK4_imp[0]
9SQL4958 Default	9SQL4958 defaults to 0h55							
9SQL4954 Name	Reserved	Reserved	BCLK3_imp[1]	BCLK3_imp[0]	BCLK2_imp[1]	BCLK2_imp[0]	Reserved	Reserved
9SQL4954 Default	9SQL4954 defaults to 0bxx0101xx							
9SQL4952 Name	Reserved	Reserved	Reserved	Reserved	BCLK1_imp[1]	BCLK1_imp[0]	Reserved	Reserved
9SQL4952 Default	9SQL4952 defaults to 0bxxxx01xx							

Table 32. Byte 14: Pull-up Pull-down Control Register 1

Byte 14	Bit7	Bit6	Bit5	Bit4	Bit3	Bit2	Bit1	Bit0
Control Function	Pull-up(pu)/ Pull-down(pd) control		Pull-up(pd)/ Pull-down(pd) control		Pull-up(pd)/ Pull-down(pd) control		Pull-up(pd)/ Pull-down(pd) control	
Type	RW	RW	RW	RW	RW	RW	RW	RW
0	00 = None	01 = pd	00 = None	01 = pd	00 = None	01 = pd	00 = None	01 = pd
1	10 = pu	11 = pu+pd	10 = pu	11 = pu+pd	10 = pu	11 = pu+pd	10 = pu	11 = pu+pd
9SQL4958 Name	OE3_pu/pd[1]	OE3_pu/pd[0]	OE2_pu/pd[1]	OE2_pu/pd[0]	OE1_pu/pd[1]	OE1_pu/pd[0]	OE0_pu/pd[1]	OE0_pu/pd[0]
9SQL4958 Default	0	1	0	1	0	1	0	1
9SQL4954 Name	OE1_pu/pd[1]	OE1_pu/pd[0]	Reserved	Reserved	OE0_pu/pd[1]	OE0_pu/pd[0]	Reserved	Reserved
9SQL4954 Default	0	1	x	x	0	1	x	x
9SQL4952 Name	OE0_pu/pd[1]	OE0_pu/pd[0]	Reserved	Reserved	Reserved	Reserved	Reserved	Reserved
9SQL4952 Default	0	1	x	x	x	x	x	x

Table 33. Byte 15: Pull-up Pull-down Control Register 2

Byte 15	Bit7	Bit6	Bit5	Bit4	Bit3	Bit2	Bit1	Bit0
Control Function	Pull-up(pd)/ Pull-down(pd) control		Pull-up(pd)/ Pull-down(pd) control		Pull-up(pd)/ Pull-down(pd) control		Pull-up(pd)/ Pull-down(pd) control	
Type	RW	RW	RW	RW	RW	RW	RW	RW
0	00 = None	01 = pd	00 = None	01 = pd	00 = None	01 = pd	00 = None	01 = pd
1	10 = pu	11 = pu+pd	10 = pu	11 = pu+pd	10 = pu	11 = pu+pd	10 = pu	11 = pu+pd
9SQL4958 Name	OE7_pu/pd[1]	OE7_pu/pd[0]	OE6_pu/pd[1]	OE6_pu/pd[0]	OE5_pu/pd[1]	OE5_pu/pd[0]	OE4_pu/pd[1]	OE4_pu/pd[0]
9SQL4958 Default	0	1	0	1	0	1	0	1
9SQL4954 Name	Reserved	Reserved	OE3_pu/pd[1]	OE3_pu/pd[0]	OE2_pu/pd[1]	OE2_pu/pd[0]	Reserved	Reserved
9SQL4954 Default	0	1	0	1	0	1	0	1
9SQL4952 Name	Reserved	Reserved	Reserved	Reserved	OE1_pu/pd[1]	OE1_pu/pd[0]	Reserved	Reserved
9SQL4952 Default	0	1	0	1	0	1	0	1

Table 34. Byte 16: Pull-up Pull-down Control Register 3

Byte 16	Bit7	Bit6	Bit5	Bit4	Bit3	Bit2	Bit1	Bit0
Control Function	Reserved	Reserved	Reserved	Reserved	Reserved	Reserved	Pull-up(pd)/ Pull-down(pd) control	
Type							RW	RW
0							00 = None	01 = pd
1							10 = pu	11 = pu+pd
Name							CKPWRGD_ PD_pu/pd[1]	CKPWRGD_ PD_pu/pd[0]
Default	0	0	1	0	0	1	1	0

Byte 17 is Reserved

Table 35. Byte 18: Polarity Control Register 2

Byte 18	Bit7	Bit6	Bit5	Bit4	Bit3	Bit2	Bit1	Bit0
Control Function	Sets OE pin polarity	Sets OE pin polarity	Sets OE pin polarity	Sets OE pin polarity	Sets OE pin polarity	Sets OE pin polarity	Sets OE pin polarity	Sets OE pin polarity
Type	RW	RW	RW	RW	RW	RW	RW	RW
0	Output enabled when OE pin is low							
1	Output enabled when OE pin is high							
9SQL4958 Name	OE7_polarity	OE6_polarity	OE5_polarity	OE4_polarity	OE3_polarity	OE2_polarity	OE1_polarity	OE0_polarity
9SQL4958 Default	0	0	0	0	0	0	0	0
9SQL4954 Name	Reserved	OE3_polarity	OE2_polarity	Reserved	OE1_polarity	Reserved	OE0_polarity	Reserved
9SQL4954 Default	0	0	0	0	0	0	0	0
9SQL4952 Name	Reserved	Reserved	OE1_polarity	Reserved	OE0_polarity	Reserved	Reserved	Reserved
9SQL4952 Default	0	0	0	0	0	0	0	0

Table 36. Byte 19: Polarity Control Register 1

Byte 19	Bit7	Bit6	Bit5	Bit4	Bit3	Bit2	Bit1	Bit0
Control Function	Reserved	Reserved	Reserved	Reserved	Reserved	Reserved	Reserved	Sets CKPWRGD_PD polarity
Type								RW
0								Power Down when Low
1								Power Down when High
Name								CKPWRGD_PD_polarity
Default	0	0	0	0	0	0	0	0

Package Outline Drawings

The package outline drawings are appended at the end of this document and are accessible from the link below. The package information is the most current data available.

9SQL4952:

www.idt.com/document/psc/nlnlg24p1-package-outline-40-x-40-mm-body-05-mm-pitch-qfn-epad-size-245-x-245-mm

9SQL4954:

www.idt.com/document/psc/32-vfqfn-package-outline-drawing-50-x-50-x-090-mm-body-epad-315-x-315-mm-nlg32p1

9SQL4958:

www.idt.com/document/psc/48-vfqfn-package-outline-drawing-60-x-60-x-090-mm-body-epad-42-x-42-mm-040mm-pitch-ndg48p2

Marking Diagrams

9SQL4952

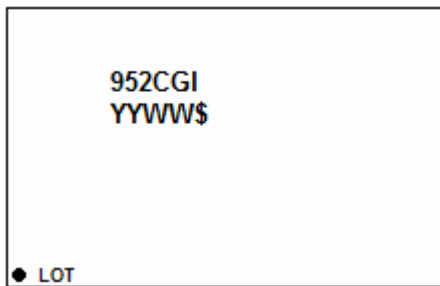

- Line 1: truncated part number.
- Line 2:
 - “YYWW” is the last two digits of the year and the work week the part was assembled.
 - “\$” denotes the mark code.
- “LOT” denotes the lot number.

9SQL4954

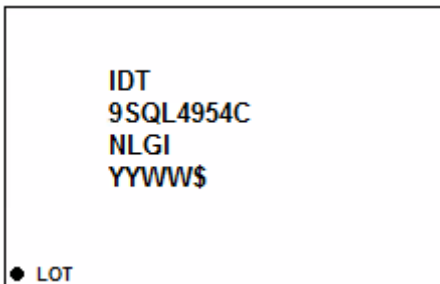

- Lines 1, 2 and 3: part number.
- Line 4:
 - “YYWW” is the last two digits of the year and the work week the part was assembled.
 - “\$” denotes the mark code.
- “LOT” denotes the lot number.

9SQL4958

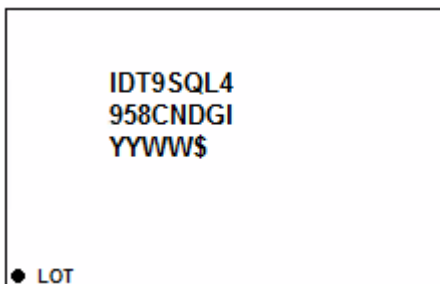

- Lines 1 and 2: part number.
- Line 3:
 - “YYWW” is the last two digits of the year and the work week the part was assembled.
 - “\$” denotes the mark code.
- “LOT” denotes the lot number.

Ordering Information

Table 37. Ordering Information

Number of Clock Outputs	Output Impedance	Orderable Part Number	Package	Temperature Range	Part Number Suffix and Shipping Method
2	85	9SQL4952CNLGI	24-VFQFPN	-40°C to +85°C	None = Trays "8" = Tape and Reel, Pin 1 Orientation: EIA-481C (see Table 38 for more details)
		9SQL4952CNLGI8			
4	85	9SQL4954CNLGI	32-VFQFPN		
		9SQL4954CNLGI8			
8	85	9SQL4958CNDGI	48-VFQFPN		
		9SQL4958CNDGI8			

"C" is the device revision designator (will not correlate with the datasheet revision).

"G" denotes Pb-free configuration, RoHS compliant.

Table 38. Pin 1 Orientation in Tape and Reel Packaging

Part Number Suffix	Pin 1 Orientation	Illustration
8	Quadrant 1 (EIA-481-C)	

Revision History

Revision Date	Description of Change
February 19, 2020	<ul style="list-style-type: none"> ▪ Updated October 22, 2019 description to include "Datasheet was also upgraded to C-rev parts." ▪ Rebranded datasheet with Renesas logos/disclaimer.
October 22, 2019	<ul style="list-style-type: none"> ▪ Combined 9SQL4952, 9SQL4954, and 9SQL4958 datasheets into one single document. ▪ Datasheet was also upgraded to C-rev parts.
October 28, 2016	Last revision date of the 9SQL4958 datasheet.
December 12, 2016	Last revision date of the 9SQL4954 datasheet.
December 8, 2016	Last revision date of the 9SQL4952 datasheet.

Notice

1. Descriptions of circuits, software and other related information in this document are provided only to illustrate the operation of semiconductor products and application examples. You are fully responsible for the incorporation or any other use of the circuits, software, and information in the design of your product or system. Renesas Electronics disclaims any and all liability for any losses and damages incurred by you or third parties arising from the use of these circuits, software, or information.
2. Renesas Electronics hereby expressly disclaims any warranties against and liability for infringement or any other claims involving patents, copyrights, or other intellectual property rights of third parties, by or arising from the use of Renesas Electronics products or technical information described in this document, including but not limited to, the product data, drawings, charts, programs, algorithms, and application examples.
3. No license, express, implied or otherwise, is granted hereby under any patents, copyrights or other intellectual property rights of Renesas Electronics or others.
4. You shall not alter, modify, copy, or reverse engineer any Renesas Electronics product, whether in whole or in part. Renesas Electronics disclaims any and all liability for any losses or damages incurred by you or third parties arising from such alteration, modification, copying or reverse engineering.
5. Renesas Electronics products are classified according to the following two quality grades: "Standard" and "High Quality". The intended applications for each Renesas Electronics product depends on the product's quality grade, as indicated below.
 - "Standard": Computers; office equipment; communications equipment; test and measurement equipment; audio and visual equipment; home electronic appliances; machine tools; personal electronic equipment; industrial robots; etc.
 - "High Quality": Transportation equipment (automobiles, trains, ships, etc.); traffic control (traffic lights); large-scale communication equipment; key financial terminal systems; safety control equipment; etc.Unless expressly designated as a high reliability product or a product for harsh environments in a Renesas Electronics data sheet or other Renesas Electronics document, Renesas Electronics products are not intended or authorized for use in products or systems that may pose a direct threat to human life or bodily injury (artificial life support devices or systems; surgical implantations; etc.), or may cause serious property damage (space system; undersea repeaters; nuclear power control systems; aircraft control systems; key plant systems; military equipment; etc.). Renesas Electronics disclaims any and all liability for any damages or losses incurred by you or any third parties arising from the use of any Renesas Electronics product that is inconsistent with any Renesas Electronics data sheet, user's manual or other Renesas Electronics document.
6. When using Renesas Electronics products, refer to the latest product information (data sheets, user's manuals, application notes, "General Notes for Handling and Using Semiconductor Devices" in the reliability handbook, etc.), and ensure that usage conditions are within the ranges specified by Renesas Electronics with respect to maximum ratings, operating power supply voltage range, heat dissipation characteristics, installation, etc. Renesas Electronics disclaims any and all liability for any malfunctions, failure or accident arising out of the use of Renesas Electronics products outside of such specified ranges.
7. Although Renesas Electronics endeavors to improve the quality and reliability of Renesas Electronics products, semiconductor products have specific characteristics, such as the occurrence of failure at a certain rate and malfunctions under certain use conditions. Unless designated as a high reliability product or a product for harsh environments in a Renesas Electronics data sheet or other Renesas Electronics document, Renesas Electronics products are not subject to radiation resistance design. You are responsible for implementing safety measures to guard against the possibility of bodily injury, injury or damage caused by fire, and/or danger to the public in the event of a failure or malfunction of Renesas Electronics products, such as safety design for hardware and software, including but not limited to redundancy, fire control and malfunction prevention, appropriate treatment for aging degradation or any other appropriate measures. Because the evaluation of microcomputer software alone is very difficult and impractical, you are responsible for evaluating the safety of the final products or systems manufactured by you.
8. Please contact a Renesas Electronics sales office for details as to environmental matters such as the environmental compatibility of each Renesas Electronics product. You are responsible for carefully and sufficiently investigating applicable laws and regulations that regulate the inclusion or use of controlled substances, including without limitation, the EU RoHS Directive, and using Renesas Electronics products in compliance with all these applicable laws and regulations. Renesas Electronics disclaims any and all liability for damages or losses occurring as a result of your noncompliance with applicable laws and regulations.
9. Renesas Electronics products and technologies shall not be used for or incorporated into any products or systems whose manufacture, use, or sale is prohibited under any applicable domestic or foreign laws or regulations. You shall comply with any applicable export control laws and regulations promulgated and administered by the governments of any countries asserting jurisdiction over the parties or transactions.
10. It is the responsibility of the buyer or distributor of Renesas Electronics products, or any other party who distributes, disposes of, or otherwise sells or transfers the product to a third party, to notify such third party in advance of the contents and conditions set forth in this document.
11. This document shall not be reprinted, reproduced or duplicated in any form, in whole or in part, without prior written consent of Renesas Electronics.
12. Please contact a Renesas Electronics sales office if you have any questions regarding the information contained in this document or Renesas Electronics products.

(Note1) "Renesas Electronics" as used in this document means Renesas Electronics Corporation and also includes its directly or indirectly controlled subsidiaries.

(Note2) "Renesas Electronics product(s)" means any product developed or manufactured by or for Renesas Electronics.

(Rev.4.0-1 November 2017)

Corporate Headquarters

TOYOSU FORESIA, 3-2-24 Toyosu,
Koto-ku, Tokyo 135-0061, Japan
www.renesas.com

Contact Information

For further information on a product, technology, the most up-to-date version of a document, or your nearest sales office, please visit:
www.renesas.com/contact/

Trademarks

Renesas and the Renesas logo are trademarks of Renesas Electronics Corporation. All trademarks and registered trademarks are the property of their respective owners.