

PART NUMBER	REV	FIRST USED
1385813-1	F	AOM/CLS
1385813-2	A	K UNIT
1385813-3	F	G UNIT
1385813-4	F	KOMAX

OBS

REVISIONS				
P	LTR	DESCRIPTION	DATE	APPD
F		REVISED PER ECR-20-006474	06MAY2020	GK GB

TERMINAL APPLIED:	
521112	
521633	
1969110	

CRIMPING DATA				
PAD LETTER	CRIMP HEIGHT	WIRE SIZE	STRIP LENGTH	
A	.070	#14	.281	
B	.065	(2)#18		
C	.061	#16		
D	.055	#18		
CRIMP	SIZE	TYPE	FEED	TERM SPEC
WIRE	.110	F	.740	114-2124
INSUL	.220	0		
INSUL RANGE	WIRE RANGE	APPLICATOR INSTRUCTION SHEET		
.110-.160	18-14	AI 8099		
(2).105MAX	(2)18	AI 8102		

- 1 RECOMMENDED SPARE PARTS.
- 2 ITEMS NOT SHOWN ON ASSEMBLY.
- 3 TOLERANCE ON CUT LENGTH TO BE ±.13.
- 4 USED ON THE CLS I AND II MACHINES ONLY. REMOVE THE TWO MOUNTING SCREWS SECURING THE PRODUCT DEREELEER AND PLACE THE PRODUCT GUIDE (ITEM 111) ON TOP OF THE MOUNTING BRACKET. REASSEMBLE AND RETIGHTEN THE TWO MOUNTING SCREWS.
- 5. SPRING LOADED TONKER (P/N 354853-1) MUST BE USED WHEN RUNNING THE APPLICATOR ON A LEADMAKER.
- 6. AIR VALVE CONVERSION KIT, PN 1633069-2 FOR KOMAX MACHINE.
- 7 GRIND BOTTOM OF ITEM 46 IF IT PROTRUDES BELOW BOTTOM OF ITEM 95.
- 8 CUT TO LENGTH AT ASSEMBLY
- 9 SHIM AS REQUIRED TO ALIGN THE POD WITH THE POD INSERTER.
- 10 SHIM MAY BE REQUIRED BETWEEN STRIP GUIDE PLATE (ITEM 53) AND REAR STRIP GUIDE (ITEM 95) TO CENTER THE TERMINAL OVER THE ANVIL.

KOMAX SET-UP INSTRUCTIONS FOR APPLICATOR 1385813-4

- * MUST USE SPRING LOADED TONKER (P/N 1-509538-7).
- * TRIGGER POINT WHEN PRESS IS MOVING UP MUST BE SET AT 1.38".
- * PROCESS SPEED MUST BE SET TO 90%.
- * ACTUATION SPEED FOR FEED CYLINDER MUST BE SET AT 350 MILLISECONDS.
- * OPTIMATION MUST BE UNCHECKED.
- * SET REFERENCE PRESS HEIGHT SETTING TO 17 ON THE PRESS SCALE.
- * WHEN SETTING TRANSFER HEIGHT, WIRE MUST BE LEVEL TO THE BOTTOM OF THE WIRE BARREL AT BOTTOM DEAD CENTER.
- * WIRE MUST BE BIASED AWAY FROM THE LONG INSULATION LEG OR STRANDING MAY OCCUR.
- * IF LONG INSULATION LEG IS CATCHING POD DURING INSERTION, SPRING LOADED TONK IS SET TOO HIGH.
- * FEED PAWL MUST BE SET UP AS CLOSE AS POSSIBLE TO THE SKATE DRAG.

THIS DRAWING IS A CONTROLLED DOCUMENT.		DWN K. STAKEM 8/24/04		
DIMENSIONS: INCHES		CHK C. ERISMAN 8/24/04		
TOLERANCES UNLESS OTHERWISE SPECIFIED:		APD T. ELBIN 8/24/04	NAME ULTRA POD FLAG APPLICATOR	
0 PLC ± - 1 PLC ± - 2 PLC ± - 3 PLC ± - 4 PLC ± - ANGLES ± - FINISH -		PRODUCT SPEC - APPLICATION SPEC -	RESTRICTED TO -	
MATERIAL -	WEIGHT -	SIZE A1	CAGE CODE 00779	DRAWING NO 1385813
CUSTOMER DRAWING		SCALE 1:1	SHEET 1 of 3	REV F

REVISIONS				
P	LTR	DESCRIPTION	DATE	APPV
-	-	SEE SHEET 1	-	-

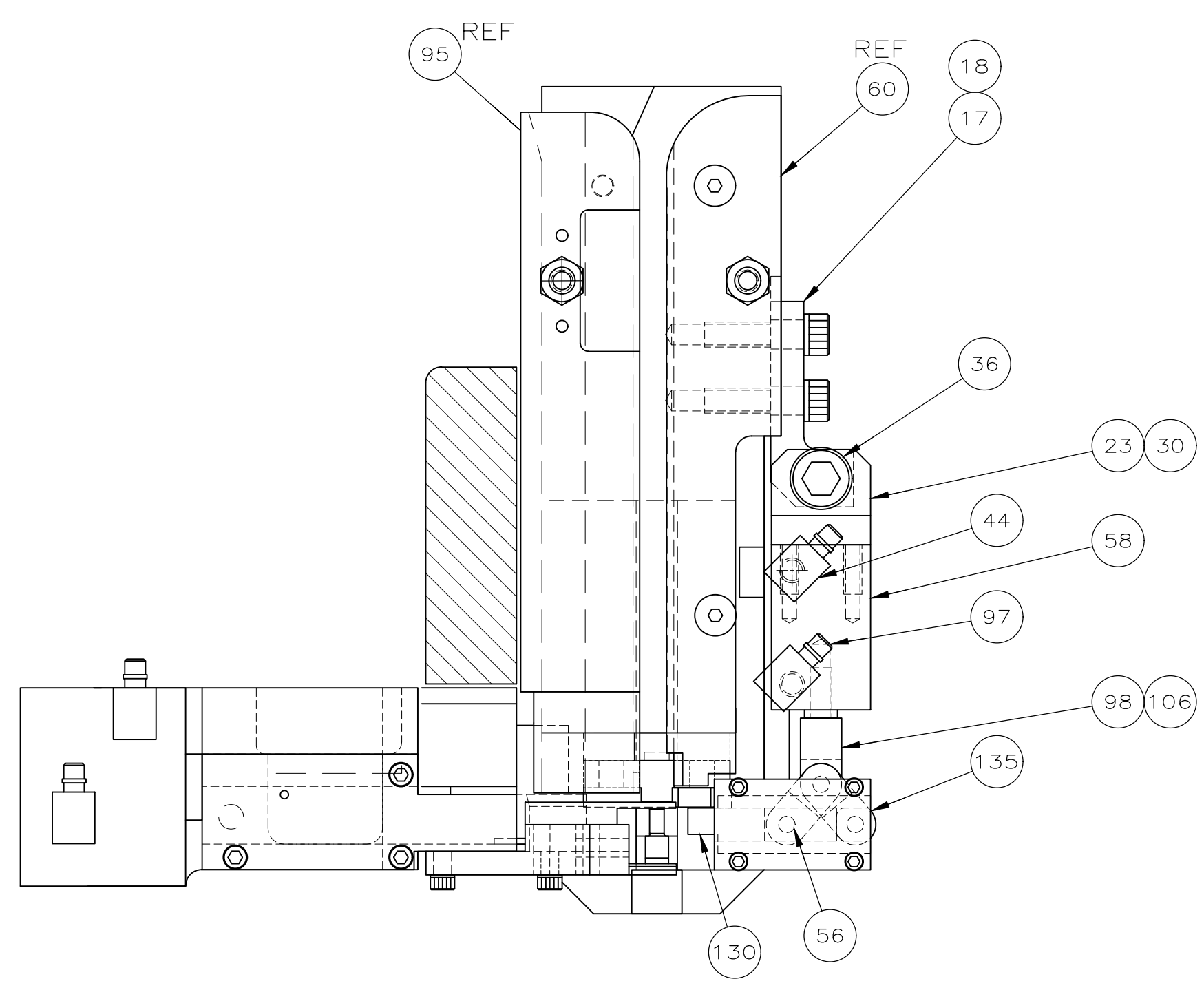

OBSOLETE

QTY	REQD	PER	ASSY	PART NO	DESCRIPTION	ITEM NO
2	2	2	2	3-354779-6	PIN, WIRE DISC (.3170)D	139
2	2	2	2	2-354779-5	PIN, WIRE DISC (.3115)C	138
2	2	2	2	1-354779-6	PIN, WIRE DISC (.3070)B	137
2	2	2	2	354779-6	PIN, WIRE DISC (.3020)A	136
2	2	2	2	1673387-1	LINK, TOGGLE	135
2	-	-	-	1424324-1	AIR LINE KIT .250 TO 4mm	134
3	18.00	-	-	27319-8	TUBING, POLY FLOW Ø.156	133
1	-	-	-	23054-1	VALVE, FLOW CONTROL	132
2	-	REF	-	679532-1	INSERT, GUARD	131
1	1	1	1	1673388-2	FINGER, BACKUP	130
-	-	-	-	-	-	129
-	-	-	-	-	-	128
-	-	-	-	-	-	127
-	-	-	-	-	-	126
1	1	1	1	679172-1	SPACER	125
-	-	-	-	-	-	124
1	1	1	1	19832-1	TIE, WIRE	123
3	27.76	27.76	27.76	18912-4	HOSE, FLEXIBLE .250 OD	122
3	25.00	25.00	25.00	27319-4	TUBE, PLASTIC .250 OD	121
2	-	-	-	90647-1	GUARD, MODIFIED	120
-	-	-	-	-	-	119
1	1	1	1	690212-1	POST, RAM	118
1	1	1	1	464249-1	PLATE, IDENTIFICATION	117
2	2	2	2	21017-2	SCR., DRIVE #2 X .19 LG	116
-	-	-	-	-	-	115
-	-	-	-	-	-	114
2	2	2	2	6-21000-7	SCR., SHC 8-32UNC X 1.75 LG	113
2	-	-	-	692655-5	VALVE ASSEMBLY	112
4	2	-	-	768411-1	GUIDE, PRODUCT	111
-	-	-	-	-	-	110
2	2	2	2	22374-7	VALVE, QUICK EXHAUST 1/8NPT	109
1	-	-	-	980282-3	CONNECTOR, TUBING, MALE	108
-	-	-	-	-	-	107
1	1	1	1	1673636-1	CLEVIS, CYLINDER	106
-	-	-	-	1-455750-3	GUARD ASSEMBLY	105
-	-	-	-	22307-1	BUSHING, PIPE, FITTING 1/4NPT	104
-	-	-	-	23791-2	TEE, PIPE, FITTING 1/4NPT	103
2	-	-	-	28580-1	FILTER, MINATURE 1/4NPT	102
-	-	-	-	22311-2	NIPPLE, CLOSE 1/4NPT	101
-	-	-	-	28582-1	LUBRICATOR 1/4NPT	100
-	-	-	-	26108-1	BODY, QUICK CONNECT	99
1	1	1	1	4-21006-5	SCR, SET, SOC CONE PT 8-32UNC X .62	98
1	1	1	1	25545-4	10-32NS MUFFLER, EXHAUST	97
1	1	1	1	18258-3	1/8NPTF CONNECTOR, TUBING TO MALE	96
10	1	1	1	852762-1	GUIDE, REAR STRIP	95
1	1	1	1	986950-1	WASHER, FLAT, PRECISION	94
2	2	2	2	6-21002-2	SCR., BHC 10-24 X .38 LG	93
1	1	1	1	1673397-1	COVER, VANE	92
2	2	2	2	2-21000-6	SCR., SHC 8-32UNC X .38 LG	91
1	1	1	1	852764-1	SHEAR, REAR	90
2	2	2	2	852765-1	SPACER, SHEAR	89
1	1	1	1	690124-1	WASHER, RAM	88
1	1	1	1	690125-1	WASHER, LAMINATED	87
1	1	1	1	852771-1	BLADE, SLUG	86
1	1	1	1	2-21000-5	SCR., SHC 8-32UNC X .25 LG	85
1	1	1	1	1213817-1	VALVE, CAM	84
1	1	1	1	690142-1	DISC, INSULATION	83
1	1	1	1	354777-1	DISC, WIRE CRIMP ADJ.	82
1	1	1	1	1-455888-7	SPACER, CRIMPER	81
-	-	-	-	-	-	80
-	-	-	-	-	-	79
1	1	1	1	1-853491-0	CRIMPER, INSULATION	78
1	1	1	1	852743-6	CRIMPER, WIRE	77
1	1	1	1	21009-6	SCR., SET, SOC 1/4-20UNC X .25 LG	76
1	1	1	1	690191-1	PLUG, NYLON	75
1	1	1	1	23030-1	SCR., SET, SOC 6-32UNC X .25 LG	74
1	1	1	1	690170-1	SPRING, COMP.	73
1	1	1	1	690603-1	SPRING, ASSIST	72
1	1	1	1	23241-6	BALL, STEEL	71
QTY	REQD	PER	ASSY	PART NO	DESCRIPTION	ITEM NO

OBSOLETE

QTY	REQD	PER	ASSY	PART NO	DESCRIPTION	ITEM NO
1	1	1	1	690686-3	SCR., BHC 5/16-24UNF X 1.00 LG	70
1	1	1	1	3-238009-4	BLOCK, CRIMPER SPACER	69
1	1	1	1	1633289-1	STABILIZER	68
1	1	1	1	1633288-2	HOLDER, STABILIZER	67
1	1	1	1	1428088-2	1/4, FITTING, Y, TUBE TO TUBE	66
1	1	1	1	22480-5	WASHER, WAVE SPRING	65
1	1	1	1	852768-3	RAM	64
1	1	1	1	856391-2	CAP, RAM	63
2	2	2	2	3-21000-9	SCR, SHC 10-32UNC X 1.00 LG	62
2	2	2	2	2-21002-3	SCR., BHC 8-32UNC X .62 LG	61
1	1	1	1	1673378-2	GUIDE, FRONT STRIP	60
1	1	1	1	1633292-1	PLATE, BASE	59
1	1	1	1	1725830-1	CYLINDER, COMPACT	58
1	1	1	1	1673389-1	MOUNT, FINGER	57
1	1	1	1	21030-1	Ø125 x .38 DOWEL PIN	56
5	5	5	5	1-21000-3	SCR., SHC 4-40UNC X .25 LG	55
4	4	4	4	21024-3	WASHER, LOC 6	54
10	1	1	1	1673379-1	PLATE, STRIP GUIDE	53
4	4	4	4	3-21002-3	SCR, BHC 1/4-20UNC X .50 LG	52
1	1	1	1	1-464451-0	ARM, STOCK DRAG	51
1	1	1	1	1-464452-3	DRAG, STOCK	50
4	4	4	4	21055-5	WASHER, FLAT 6	49
1	1	1	1	2-460680-8	FEED FINGER ASSEMBLY	48
2	2	2	2	986377-1	VALVE, LEVER ROLLER	47
7	2	2	2	22354-6	STUD 8-32UNC X 1.00 LG	46
4	4	4	4	18326-2	ELBOW, TUBE TO MALE 10-32NPT	45
5	5	5	5	18258-1	CONN., MALE TUBE TO MALE THD 10-32NPT	44
1	1	1	1	1673390-1	COVER, FINGER	43
-	-	-	-	-	-	42
8	1	1	1	1-21002-4	SCR, BHC 4-40UNC X .38 LG	41
2	2	2	2	3-21002-3	SCR, BHC 1/4-20UNC X .50 LG	40
4	4	4	4	2-21000-3	SCR., SHC 6-32UNC X .88 LG	39
3	3	3	3	2-22733-8	SCR., BHC 1/4-20UNC X .63 LG	38
1	1	1	1	1752764-1	HOUSING, APPLICATOR	37
1	1	1	1	21004-1	SCR, SHLD .25 DIA X .38 LG	36
4	4	4	4	21000-9	SCR., SHC 2-56 X .19 LG	35
1	1	1	1	2-21002-6	SCR., SHC 10-32UNC X .38 LG	34
-	-	-	-	-	-	33
1	1	1	1	354993-2	CYL., AIR, DOUBLE ACTING 1/8NPT	32
-	-	-	-	-	-	31
2	2	2	2	1-21000-8	SCR., BHC 6-32UNC X .25 LG	30
2	2	2	2	23238-1	INSERT, COUPLING	29
1	1	1	1	1-23470-7	SPRING, COMP .240 DIA X 2.50 LG	28
2	2	2	2	2-21002-4	SCR., BHC 8-32UNC X .75 LG	27
1	1	1	1	22733-8	SCR., BHC 8-32UNC X .38 LG	26
1	1	1	1	853088-8	ANVIL	25
1	1	1	1	1673377-1	SHEAR, FRONT	24
1	1	1	1	1673385-1	EYE, CYLINDER	23
1	1	1	1	461690-3	SPACER, AIR FEED	22
2	2	2	2	3-21000-4	SCR., SHC 10-32UNF X .38 LG	21
2	2	2	2	21055-7	WASHER, FLAT 10	20
1	1	1	1	1213818-1	BRACKET, VALVE	19
2	2	2	2	3-21000-5	SCR., SHC 10-32 X .50 LG	18
1	1	1	1	1673386-1	MOUNT, CYLINDER	17
2	2	2	2	21024-5	WASHER, LOCK #10	16
2	2	2	2	4-21000-2	SCR., SHC 10-32UNF X 1.75 LG	15
1	1	1	1	1804005-1	INSERTER	14
2	2	2	2	21022-2	NUT, FLEX 8-32UNC	13
2	2	2	2	2-21002-1	SCR., 8-32UNC X .38 LG	12
2	2	2	2	2-21006-3	SCR., SET, SOC CONE PT 4-40UNC X .38 LG	11
2	2	2	2	21018-4	NUT, HEX 4-40UNC	10
2	2	2	2	22281-6	SPRING, COMP. .300 DIA X .44 LG	9
3	2	2	2	22306-1	1/8 MOD NPT ELBOW, STREET, 90°	8
1	1	1	1	25545-1	1/8NPT MUFFLER, EXHAUST	7
-	-	-	-	-	-	6
9	1	1	1	1673395-1	INSERTER, MOUNT	5
3	2	2	2	22304-1	NIPPLE, HEX PIPE 1/8NPT	4
1	1	1	1	985836-1	VALVE, TOGGLE 1/8NPT	3
1	1	1	1	1-460277-2	AIR FEED ASSEMBLY	2
-	1	1	1	985883-2	CONN., TUBING, MALE 1/8NPT-1/4 TUBE	1
QTY	REQD	PER	ASSY	PART NO	DESCRIPTION	ITEM NO

THIS DRAWING IS A CONTROLLED DOCUMENT.

DIMENSIONS: INCHES	TOLERANCES UNLESS OTHERWISE SPECIFIED:	DIN K. STAKEM 8/24/04	TE Connectivity
0 PLC ± .005	1 PLC ± .005	CHK C. FERISMAN 8/24/04	NAME ULTRA POD FLAG APPLICATOR
2 PLC ± .005	3 PLC ± .005	APVD T. ELBIN 8/24/04	PRODUCT SPEC
4 PLC ± .005	ANGLES ± .005	APPLICATION SPEC	SIZE CAGE CODE DRAWING NO RESTRICTED TO
MATERIAL	FINISH	WEIGHT	A1 00779C=1385813
CUSTOMER DRAWING		SCALE 1:1	SHEET 3 OF 3 REV F