

THIS DRAWING IS UNPUBLISHED. RELEASED FOR PUBLICATION NOV ,2001.  
 © COPYRIGHT 2001 BY TYCO ELECTRONICS CORPORATION. ALL RIGHTS RESERVED.

LOC	DIST	REVISIONS			
P	LTR	DESCRIPTION	DATE	DWN	APVD
J					
	D1	ECR-10-014776	20JUL10	B.W	S.Y

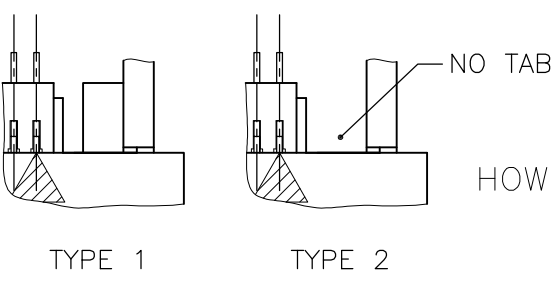

HOW TO MATE AND UNMATE  
 MATE: ① → ④  
 UNMATE: ⑤ → ⑦

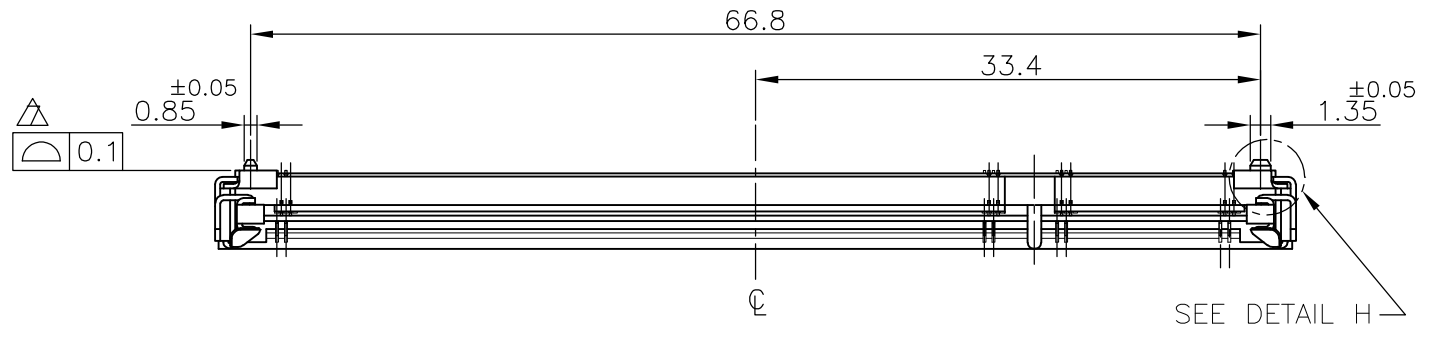
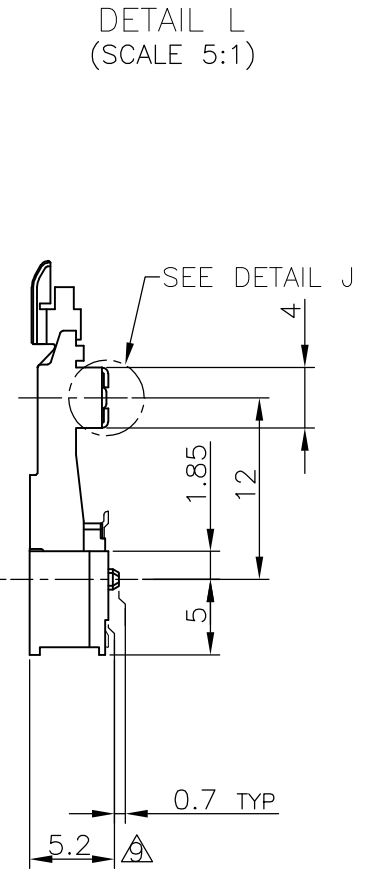
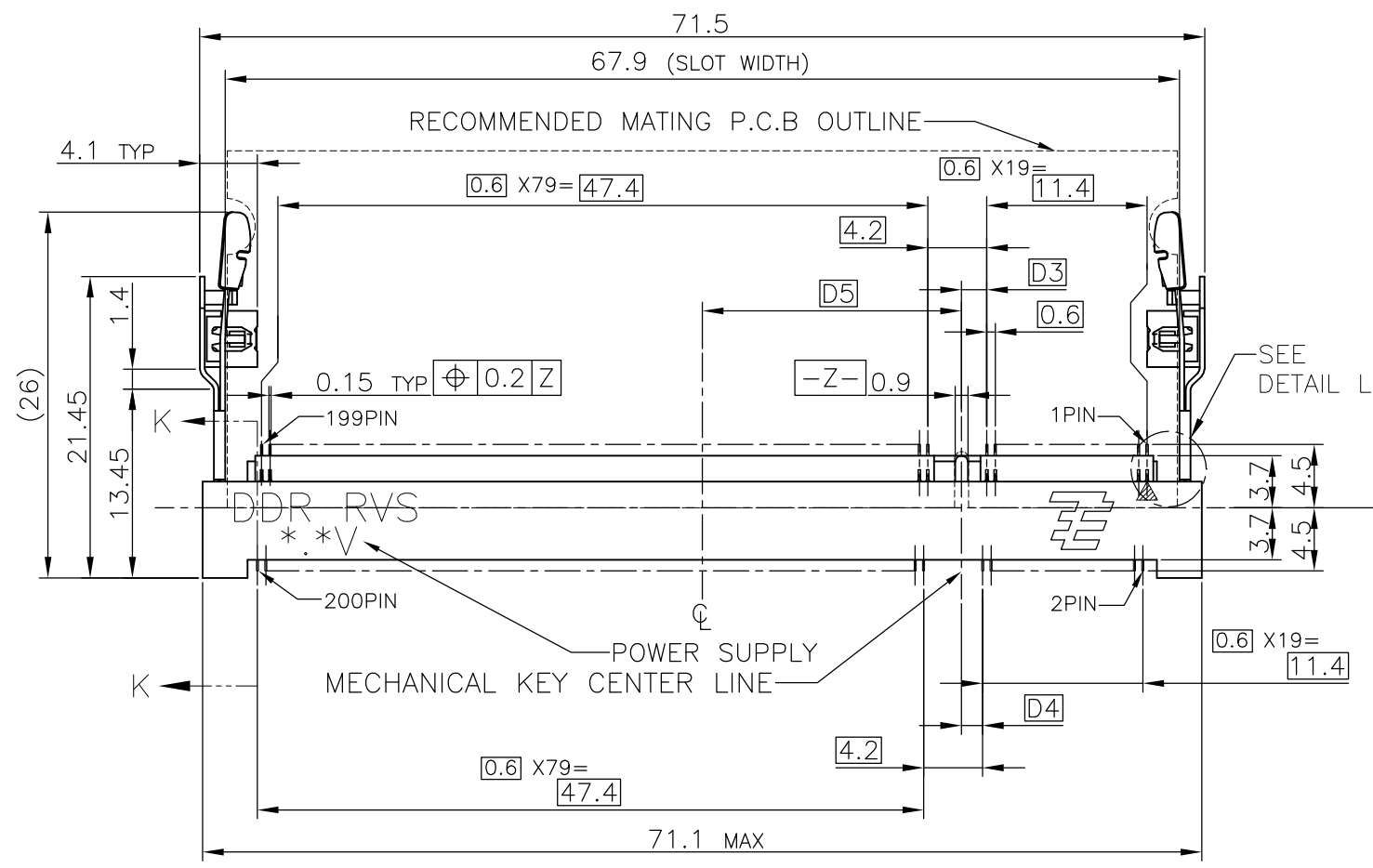
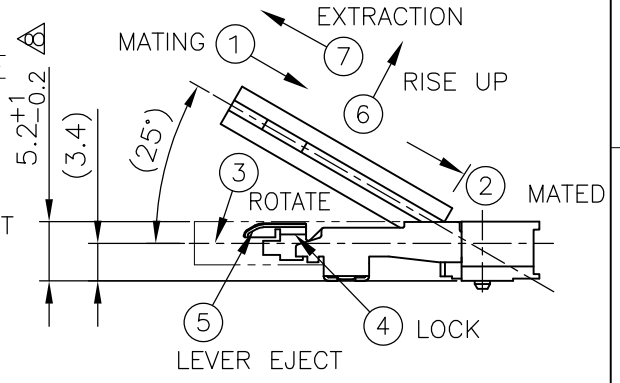

- (APPLIED TO SHEET 1-2)
- MATERIAL ; HOUSING: HIGH TEMPERATURE THERMO PLASTIC UL94V-0  
 CONTACT: COPPER ARROY  
 LOCK LEVER: STAINLESS STEEL  
 SOLDER PEG: COPPER ARROY
  - FINISH ; CONTACT AREA: GOLD FLASH ON 0.0013MIN ALL OVER NICKEL.  
 SOLDERING AREA: GOLD FLASH PLT.  
 SOLDER PEG: TIN PLATING.
- ⊕ MECHANICAL KEY POSITION OF CONNECTOR SEE TABLE.
  - ⊕ TOLERANCES NON-CUMULATIVE.
  - ⊕ NOT TO SCALE.
  - ⊕ [ ] INSIDE MUST BE RESIST COAT EXCEPT SOLDER PATTERN.
  - ⊕ COPLANARITY : 0.1 MAX.
  - ⊕ THE FLOATING VALUE BY SOLDERING IS NOT INCLUDED.
  - ⊕ NOT MATING CONDITION.
- 10 IF THE MODULE DOESN'T INSERT AND LOCK IN THE LATCH SMOOTHLY, OPEN WIDE BOTH LATCHES BY MANUAL. AND THE MODULE MUST BE INSERTED AND LOCKED IN THE LATCH.

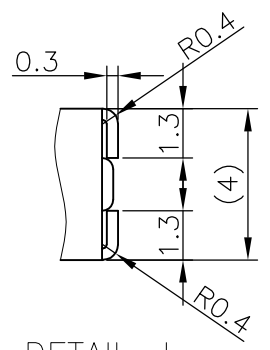
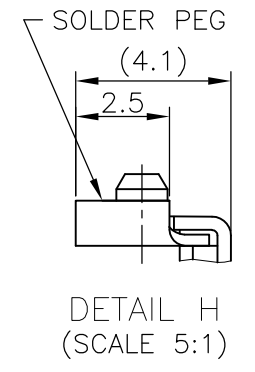
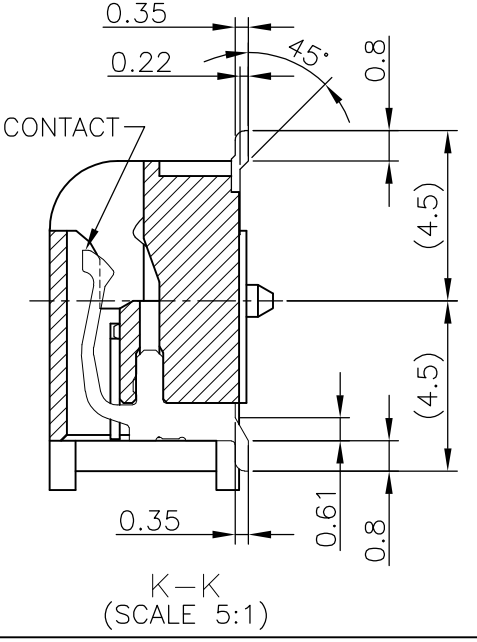

GENERAL TOLERANCE  
 10 ≥ : ±0.2  
 30 ≥ > 10 : ±0.25  
 100 ≥ > 30 : ±0.3  
 ANGLES : ±3°

TYPE 2	AVAILABLE	—H—	1.8V (DDR2)	17.55	2.4	2.7	200	1717379-4
TYPE 1	AVAILABLE	—H—	2.5V (DDR1)	18.45	1.5	1.8	200	1717379-1
TAB TYPE	TOOLING STATUS	REMARK	POWER SUPPLY (TYPE)	D5	D4	D3	POS	PART NO.

THIS DRAWING IS A CONTROLLED DOCUMENT.

DWN	B.WONG	20JUL10		Tyco Electronics AMP K.K.				
CHK	C.WANG	20JUL10		Kawasaki, Japan				
APVD	S.YAO	20JUL10		NAME				
PRODUCT SPEC	108-5701			DDR1 & DDR2 SODIMM SOCKET				
APPLICATION SPEC			0.6mm PITCH 200POS					
WEIGHT	4.7g		STANDARD PROFILE REVERSE TYPE					
CUSTOMER DRAWING	SIZE	A3	CAGE CODE	00779	DRAWING NO	C-1717379	RESTRICTED TO	
	SCALE	2:1	SHEET	1	OF	4	REV	D1

THIS DRAWING IS UNPUBLISHED. RELEASED FOR PUBLICATION NOV ,2001.  
 © COPYRIGHT 2001 BY TYCO ELECTRONICS CORPORATION. ALL RIGHTS RESERVED.

LOC	DIST	REVISIONS					
J		P	LTR	DESCRIPTION	DATE	DWN	APVD
		-	-	SEE SHEET 1	-	-	-

# REFERENCE P.C. BOARD PATTERN LAYOUT (CONNECTOR MOUNTING SIDE)

D

D

C

C

B

B

A

A

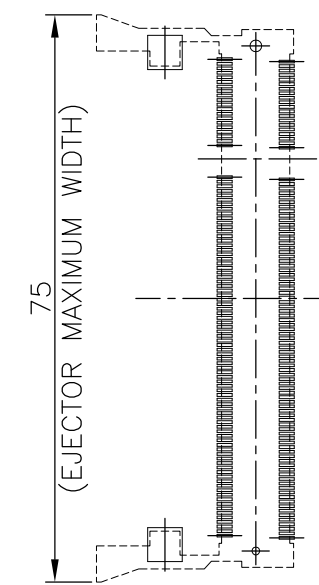

REAL SIZE (SCALE 1:1)

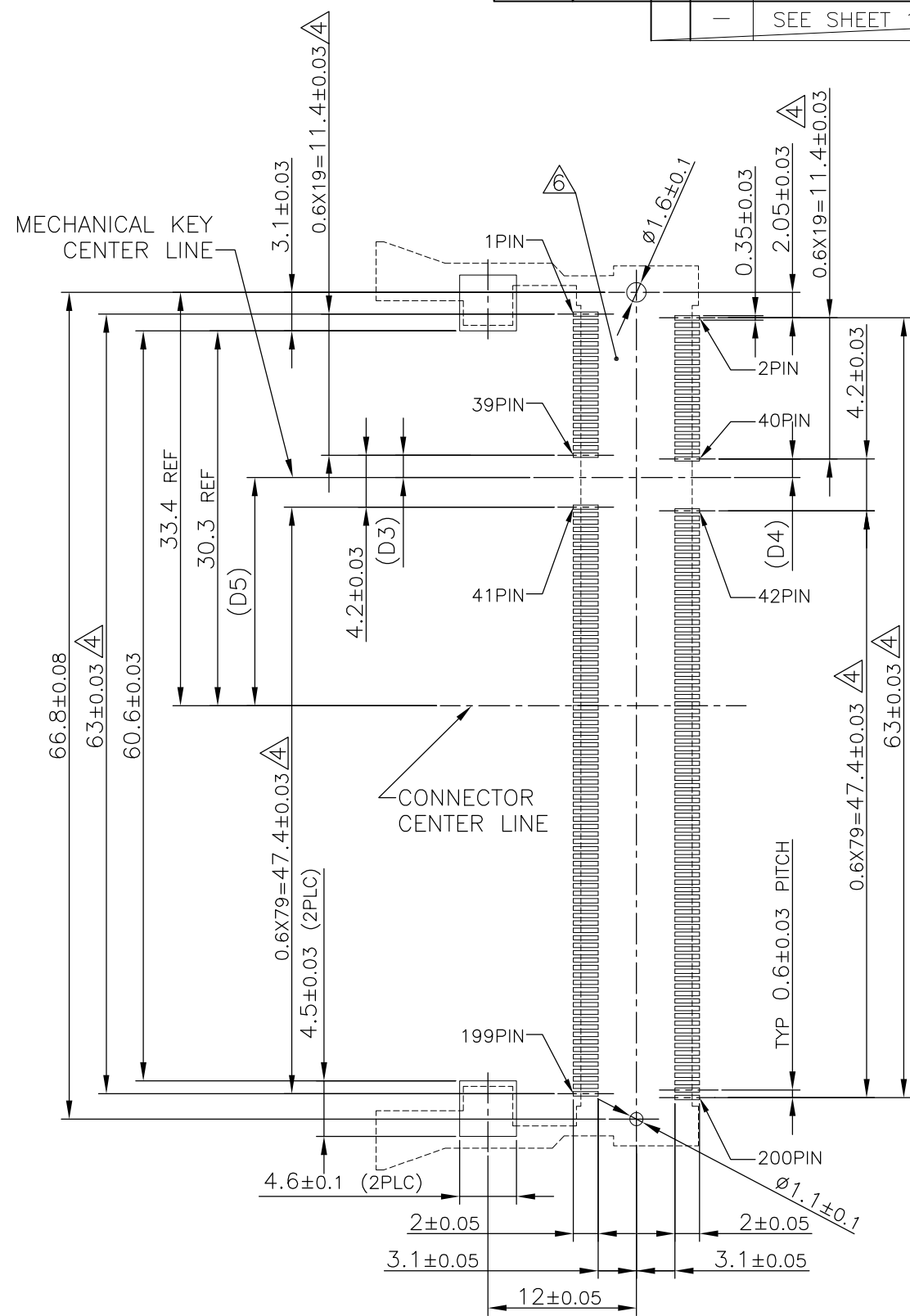

1.8V	17.55	2.4	2.7
2.5V	18.45	1.5	1.8
POWER SUPPLY	D5	D4	D3

THIS DRAWING IS A CONTROLLED DOCUMENT.		DWN	Tyco Electronics		Tyco Electronics AMP K.K.	
DIMENSIONS: MM		CHK	NAME		Kawasaki, Japan	
TOLERANCES UNLESS OTHERWISE SPECIFIED:		APVD	DDR1 & DDR2 SODIMM SOCKET			
0 PLC ±		PRODUCT SPEC	0.6mm PITCH 200POS			
1 PLC ±		APPLICATION SPEC	STANDARD PROFILE REVERSE TYPE			
2 PLC ±		SIZE	CAGE CODE	DRAWING NO	RESTRICTED TO	
3 PLC ±		A3	00779	C-1717379	-	
4 PLC ±		WEIGHT	CUSTOMER DRAWING			
ANGLES ±		SCALE 2:1		SHEET 2 OF 4		REV D1
FINISH						

THIS DRAWING IS UNPUBLISHED. RELEASED FOR PUBLICATION NOV. 2001.  
 © COPYRIGHT 2001 BY TYCO ELECTRONICS CORPORATION. ALL RIGHTS RESERVED.

LOC	DIST	REVISIONS			
P	LTR	DESCRIPTION	DATE	DWN	APVD
J		SEE SHEET 1	-	-	-

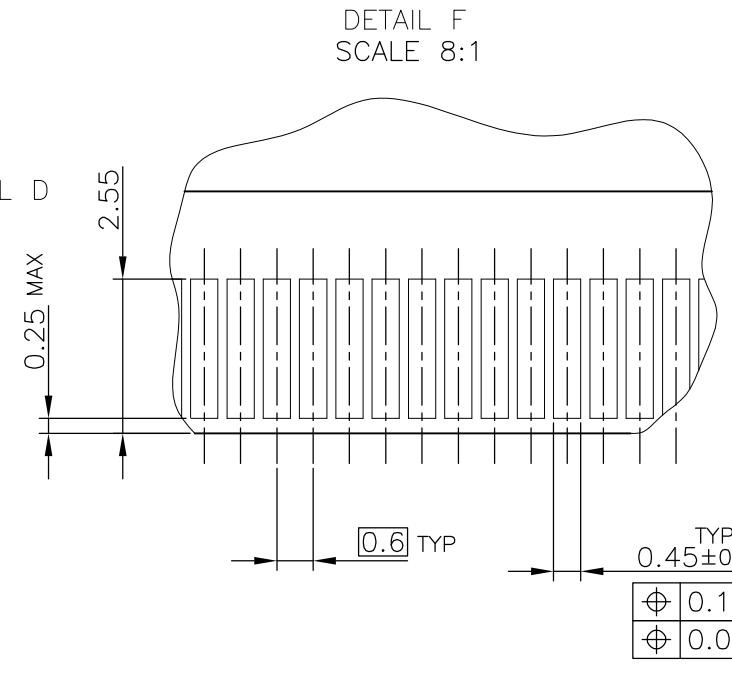
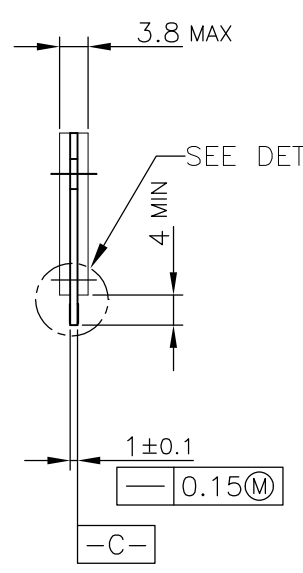
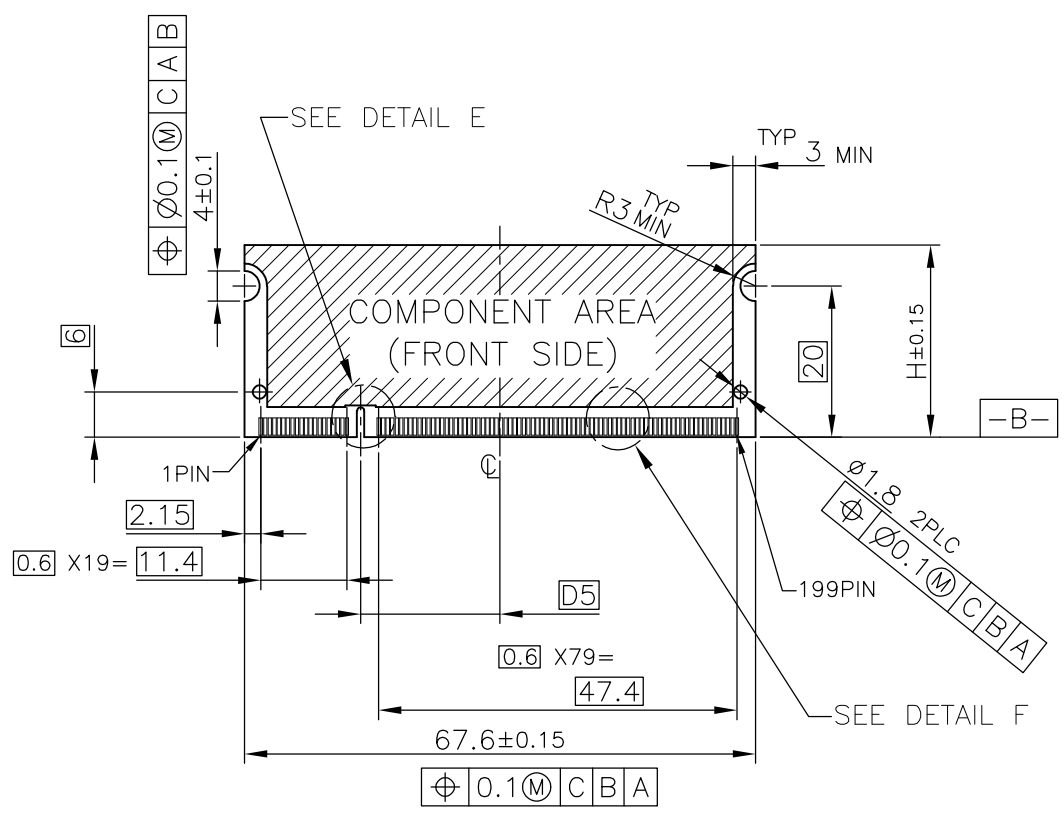

- (APPLIED TO SHEET 3)
1. TOLERANCES ON ALL DIMENSIONS ±0.15 UNLESS OTHERWISE SPECIFIED.
  2. P.C. BOARD THICKNESS APPLIES ACROSS TABS AND INCLUDES PLATING AND/OR METALIZATION.
  3. FINISH OF PAD : GOLD PLATING 0.00076 MIN. OVER Ni PLATING 0.002MIN.
- NO BURR  
 CHAMFER 0.25 MAX x 45° IF EXIST.

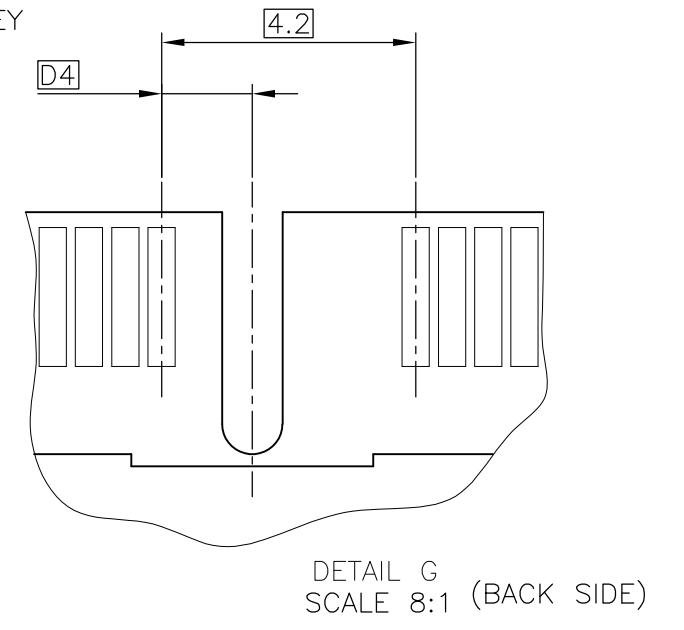
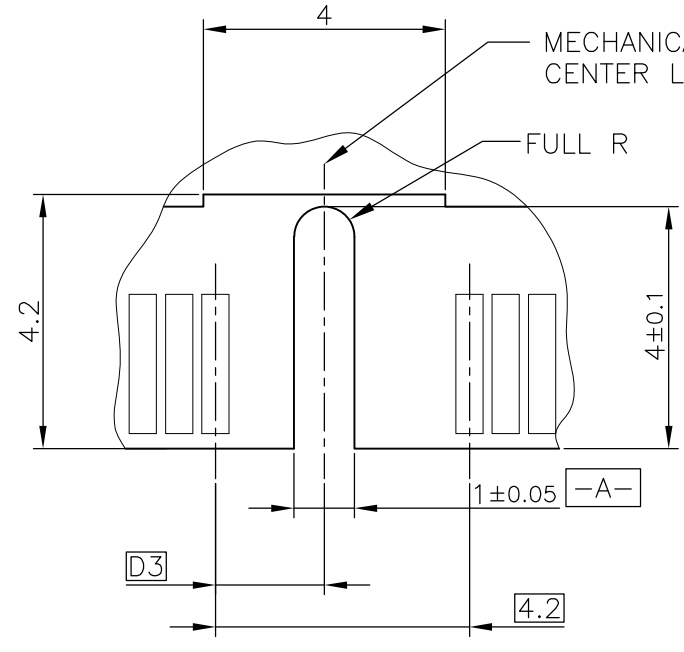
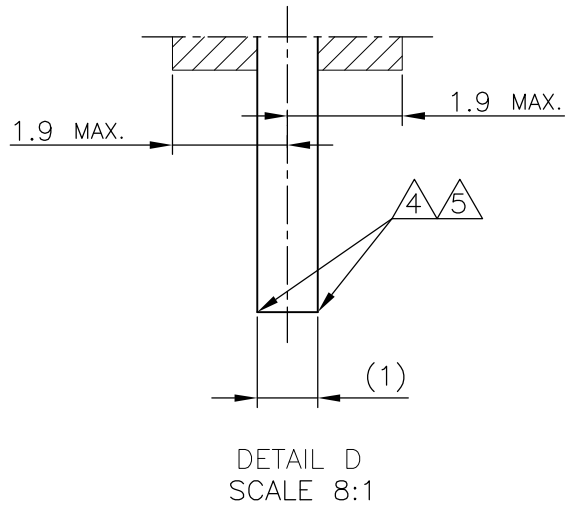
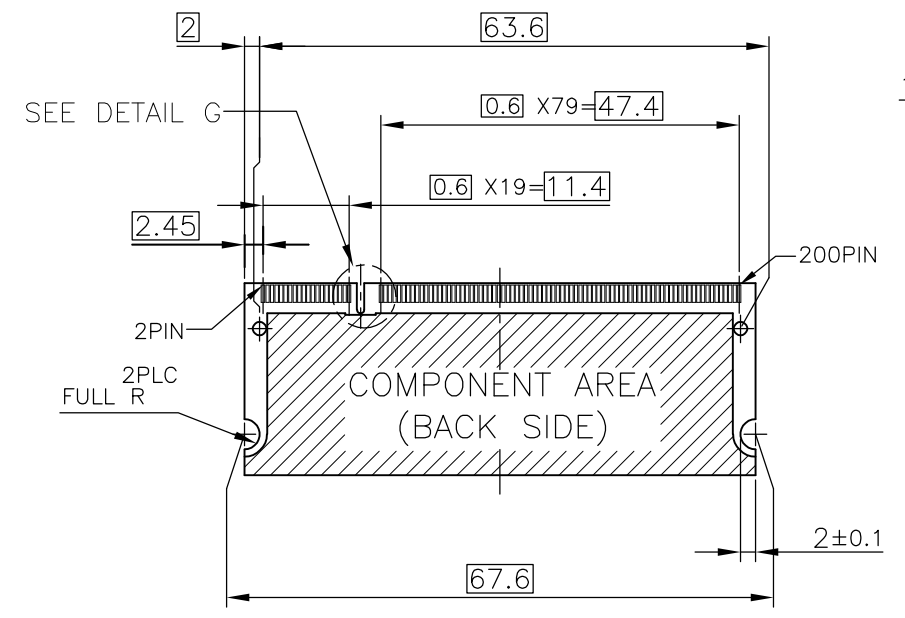

RECOMMENDED MATING P.C.B CONFIGURATION

THIS DRAWING IS A CONTROLLED DOCUMENT.		DWN	Tyco Electronics AMP K.K. Kawasaki, Japan			
DIMENSIONS: MM		CHK	NAME			
TOLERANCES UNLESS OTHERWISE SPECIFIED:		APVD	DDR1 & DDR2 SODIMM SOCKET			
0 PLC ±		PRODUCT SPEC	0.6mm PITCH 200POS			
1 PLC ±		APPLICATION SPEC	STANDARD PROFILE REVERSE TYPE			
2 PLC ±		WEIGHT	SIZE	CAGE CODE	DRAWING NO	RESTRICTED TO
3 PLC ±		CUSTOMER DRAWING	A3	00779	C-1717379	-
4 PLC ±			SCALE	SHEET	OF	REV
ANGLES ±			2:1	3	4	D1
FINISH						

THIS DRAWING IS UNPUBLISHED. RELEASED FOR PUBLICATION NOV ,2001.  
 © COPYRIGHT 2001 BY TYCO ELECTRONICS CORPORATION. ALL RIGHTS RESERVED.

LOC	DIST	REVISIONS					
		P	LTR	DESCRIPTION	DATE	DWN	APVD
J		-	-	SEE SHEET 1	-	-	-

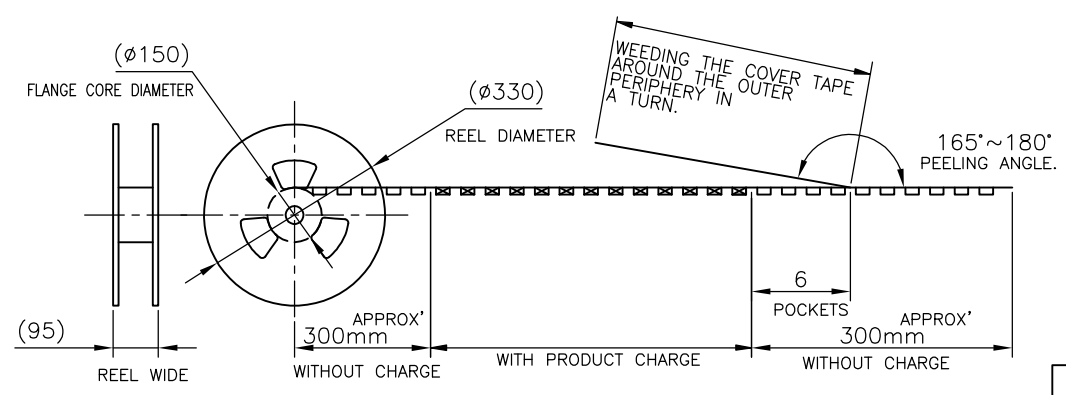
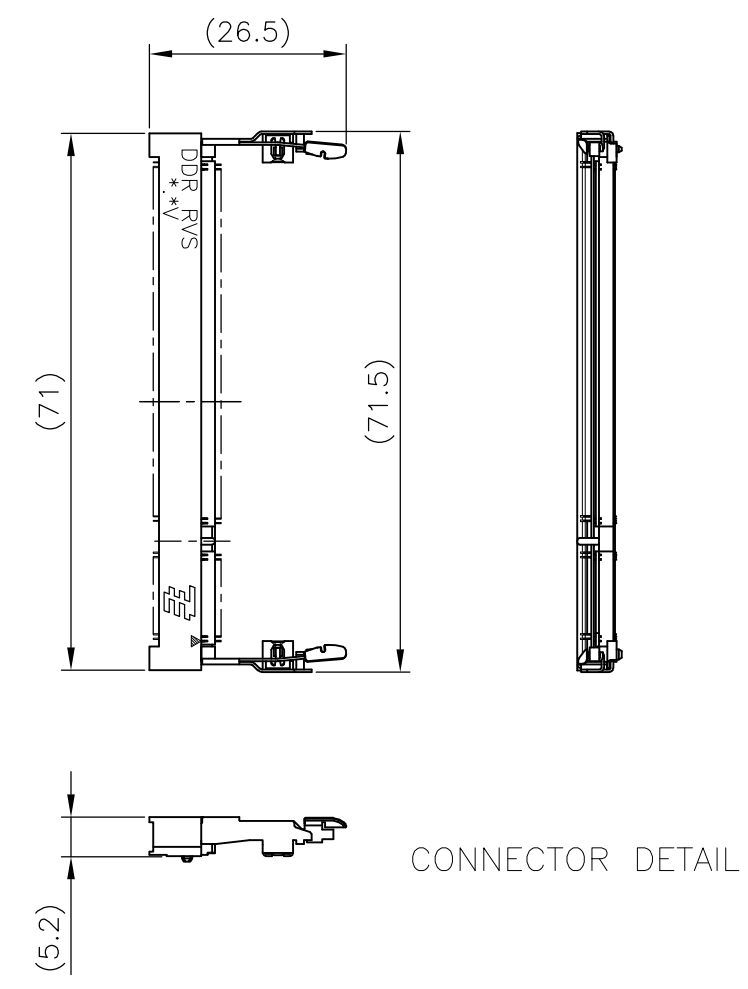
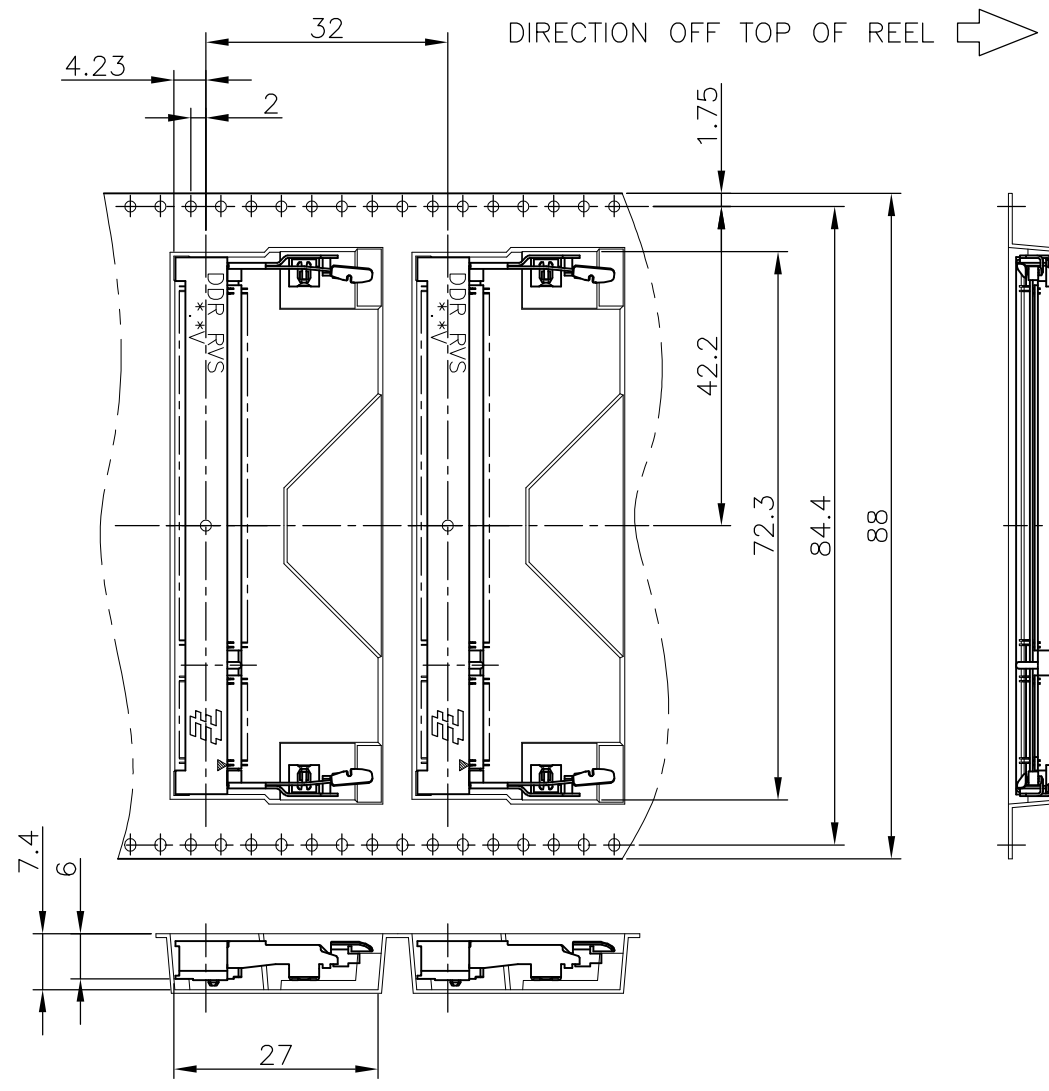

1.8V (DDR2)	150EA/REEL	1717379-4
2.5V (DDR1)	150EA/REEL	1717379-1
POWER SUPPLY (TYPE)	QTY	P/N

THIS DRAWING IS A CONTROLLED DOCUMENT.		DWN	Tyco Electronics AMP K.K. Kawasaki, Japan		
DIMENSIONS: MM		CHK	NAME		
TOLERANCES UNLESS OTHERWISE SPECIFIED:		APVD	DDR1 & DDR2 SODIMM SOCKET 0.6mm PITCH 200POS STANDARD PROFILE REVERSE TYPE		
0 PLC ±		PRODUCT SPEC	SIZE		
1 PLC ±		APPLICATION SPEC	CAGE CODE	DRAWING NO	RESTRICTED TO
2 PLC ±		WEIGHT	A3	00779	C-1717379
3 PLC ±		CUSTOMER DRAWING			
4 PLC ±		SCALE	1:1	SHEET	4 OF 4
ANGLES ±		REV D1			
FINISH					