

KA7405D

2-Channel DC Motor Drive IC

Features

- Output current up to 1.5A (Each channel).
- 4-function modes (CW, CCW, stop and brake) are controlled by 2-logic circuits.
- Operating voltage range: $V_{CC} = 2.5 \sim 6.0V$.
- Built-in spike killer diode.
- Low saturation voltage.

Description

The KA7405D is a monolithic integrated circuit, and suitable for the zoom and reel motor driver for camera, tape deck, any other consumer and industrial applications.

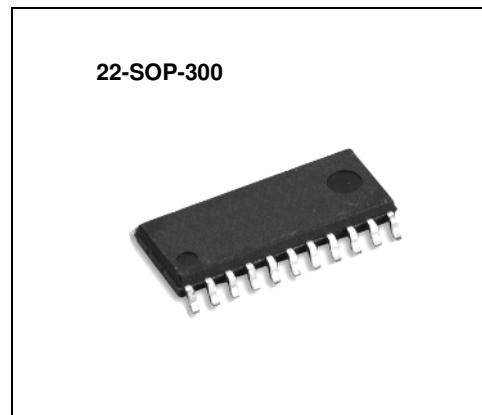

Typical Applications

- Camera zoom and film motors
- General DC motor

Ordering Information

Device	Package	Operating Temp.
KA7405D	22-SOP-300	-25°C to +75°C

Pin Assignments

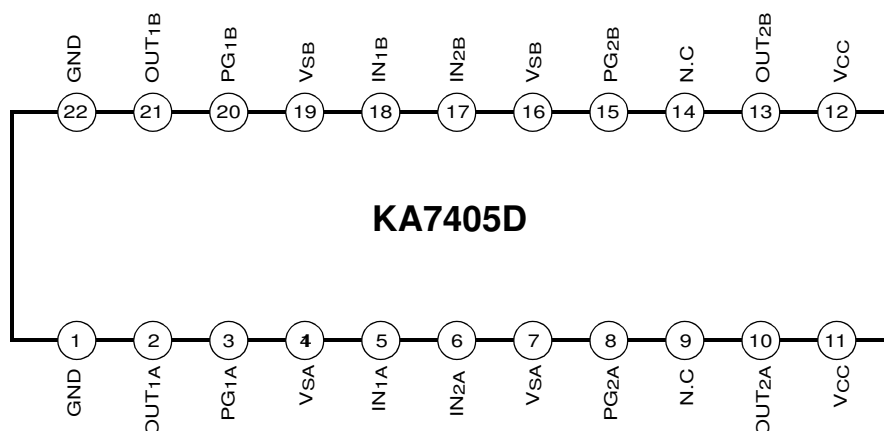

Pin Definitions

Pin Number	Pin Name	I/O	Pin Function Description	Remark
1	GND	-	Signal ground	-
2	OUT1A	O	Output 1	Channel A
3	PG1A	-	Power ground 1	Channel A
4	VSA	-	Output supply voltage	Channel A
5	IN1A	I	Input 1	Channel A
6	IN2A	I	Input 2	Channel A
7	VSA	-	Output supply voltage	Channel A
8	PG2A	-	Power ground 2	Channel A
9	NC	-	No connection	-
10	OUT2A	O	Output 2	-
11	VCC	-	Supply voltage	-
12	VCC	-	Supply voltage	-
13	OUT2B	O	Output 2	Channel B
14	NC	-	No connection	-
15	PG2B	-	Power ground 2	Channel B
16	VSB	-	Output supply voltage	Channel B
17	IN2B	I	Input 2	Channel B
18	IN1B	I	Input 1	Channel B
19	VSB	-	Output supply voltage	Channel B
20	PG1B	-	Power ground 1	Channel B
21	OUT1B	O	Output 1	Channel B
22	GND	-	Signal ground	-

Internal Block Diagram

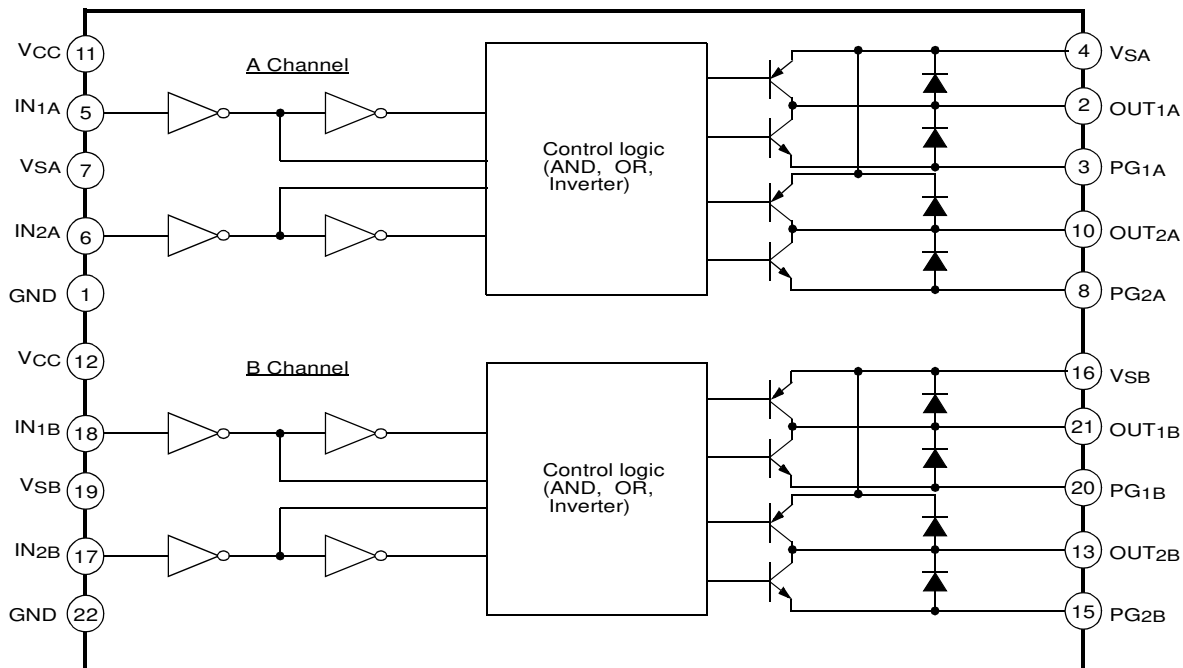

Equivalent Circuits

Description	Pin No.	Internal Circuit
Control Input		
IN1A	5	
IN2A	6	
IN1B	18	
IN2B	17	
VCC	11, 12	
GND	1, 22	
Motor Output		
OUT1A	2	
OUT2A	10	
OUT1B	21	
OUT2B	13	
VSA	4, 7	
VSB	16, 19	
PG1A	3	
PG2A	8	
PG1B	20	
PG2B	15	

Absolute Maximum Ratings (Ta = 25°C)

Parameter	Symbol	Value	Unit
Power supply voltage	V _{CCMAX}	6.0	V
Channel supply voltage	V _{SMAX}	6.0	V
Power dissipation	P _D	1000	mW
Operating temperature	T _{OPR}	-25 ~ +75	°C
Storage temperature	T _{STG}	-40 ~ +125	°C
Output current	I _{OMAX}	1.5	A

Power Dissipation Curve

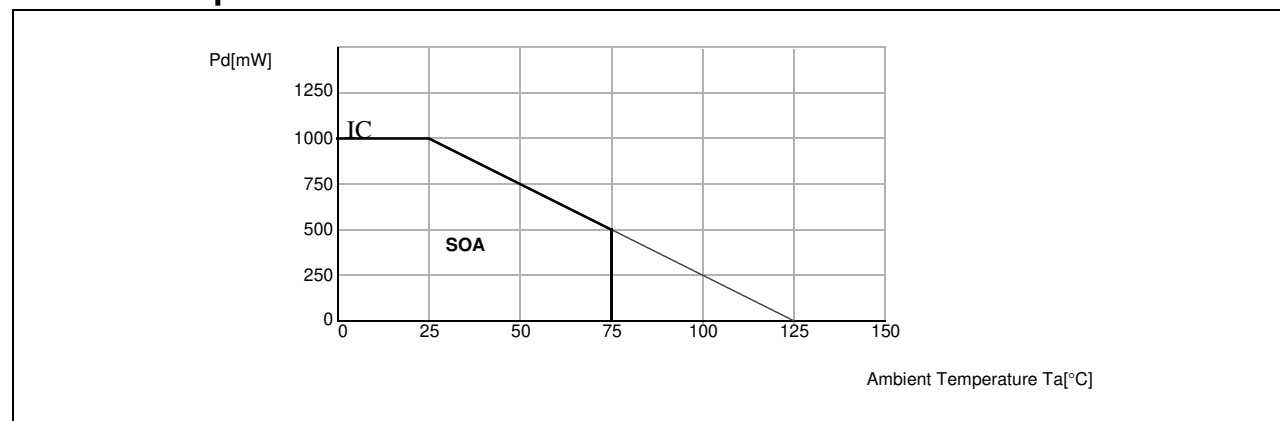

Recommended Operating Conditions (Ta = 25°C)

Parameter	Symbol	Min.	Typ.	Max.	Unit
Operating supply voltage	V _{CC}	2.5	-	6.0	V

Electrical Characteristics

(VCC=3V, Ta=25°C, unless otherwise specified)

Parameter	Symbol	Conditions	Min.	Typ.	Max.	Unit
Supply current 1	ICC1	V _{IN(all)} = 0V, V _{CC} =5V	-	0.1	10	μA
Supply current 2	ICC2	V _{IN1} =3V, V _{CC} =5V	-	15	30	mA
Supply current 3	ICC3	V _{IN2} =3V, V _{CC} =5V	-	15	30	mA
Supply current 4	ICC4	V _{IN} =3V	-	30	50	mA
Input current	I _{IN}	V _{CC} =6V, V _{IN} =2V	-	45	80	μA
Leakage current	I _{IK}	V _{CC} =5V	-	0.1	10	μA
Upper spark diode forward voltage	V _{SF1}	I _O =500mA	-	1.0	1.7	V
Lower spark diode forward voltage	V _{SF2}	I _O =500mA	-	1.0	1.7	V
Output saturation voltage (1A)	V _{O1A}	I _O A=300mA, V _{IN1A} =3V	-	0.45	0.70	V
Output saturation voltage (1B)	V _{O1B}	I _O B=300mA, V _{IN1B} =3V	-	0.45	0.70	V
Output saturation voltage (2A)	V _{O2A}	I _O A=600mA, V _{IN1A} =3V	-	1.0	1.5	V
Output saturation voltage (2B)	V _{O2B}	I _O B=600mA, V _{IN1B} =3V	-	1.0	1.5	V
Output saturation voltage (3A)	V _{O3A}	I _O A=300mA, V _{IN2A} =3V	-	0.45	0.70	V
Output saturation voltage (3B)	V _{O3B}	I _O B=300mA, V _{IN2B} =3V	-	0.45	0.70	V
Output saturation voltage (4A)	V _{O4A}	I _O A=600mA, V _{IN2A} =3V	-	1.0	1.5	V
Output saturation voltage (4B)	V _{O4B}	I _O B=600mA, V _{IN2B} =3V	-	1.0	1.5	V
Output saturation voltage 5	V _{O5}	I _O B=600mA, V _{IN1} =3V	-	0.6	0.8	V
Output saturation voltage 6	V _{O6}	I _O =600mA, V _{IN2} =3V	-	0.6	0.8	V
Output saturation voltage 7	V _{O7}	I _O =1200mA, V _{IN1} =3V	-	1.2	1.6	V
Output saturation voltage 8	V _{O8}	I _O =1200mA, V _{IN2} =3V	-	1.2	1.6	V
Output sustain voltage	V _{SUS}	I _O =200mA	10	15	-	V
Output saturation low voltage A ^{note}	V _{OLA}	V _{CC} =1.9V, I _O A=400mA	-	0.45	0.90	V
Output saturation low voltage B ^{note}	V _{OLB}	V _{CC} =1.9V, I _O B=400mA	-	0.45	0.90	V

Notes:

User's option.

Operation Truth Table

Input/Output Motor Operation	Input 1	Input 2	Output 1	Output 2	Remark
Stop	Low	Low	Off	Off	High impedance
Forward Operation	Low	High	Low	High	CW / CCW
Backward Operation	High	Low	High	Low	CCW / CW
Fast stop	High	High	Low	Low	Brake

Typical Performance Characteristics

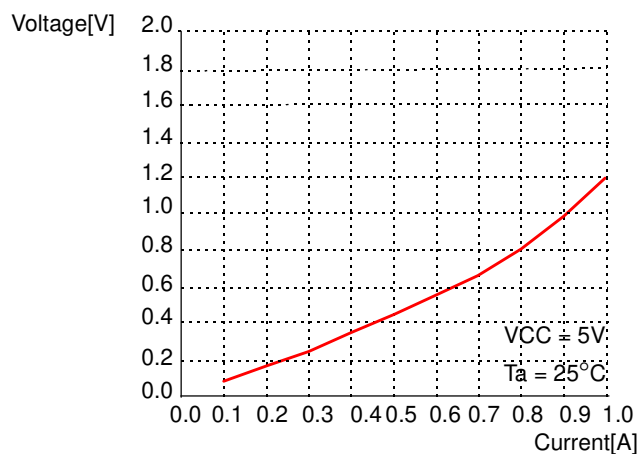

Figure 1. PNP Saturation Voltage

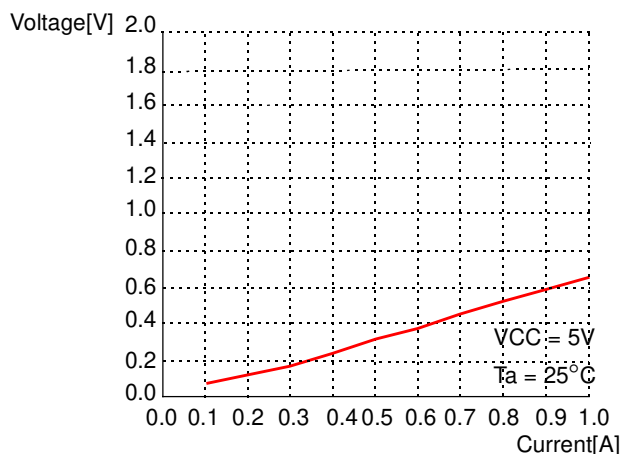
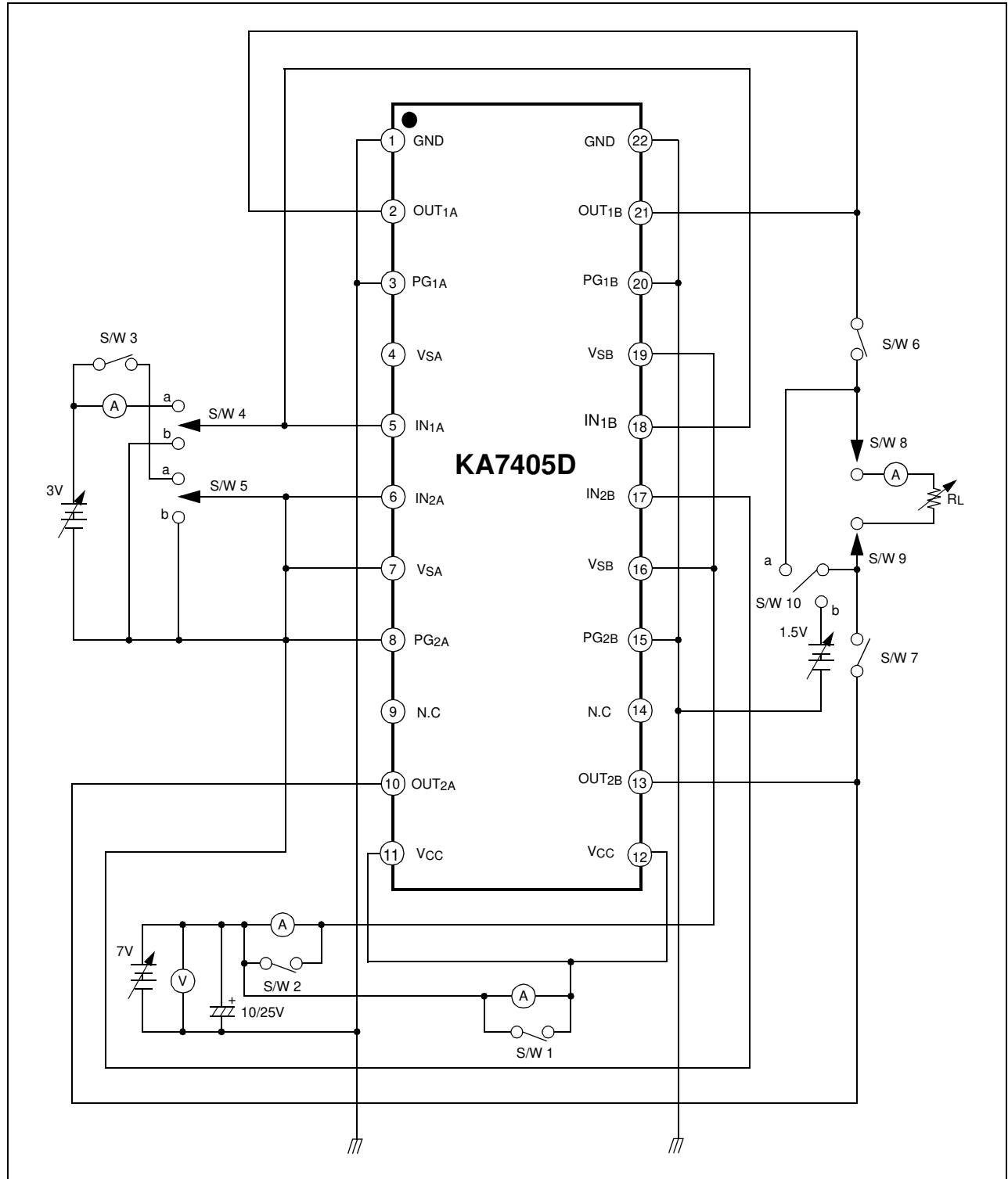

Figure 2. PNP Saturation Voltage

Test Circuits



Test Conditions

Characteristics	SW1	SW2	SW3	SW4	SW5	SW6	SW7	SW8	SW9	SW10	Remark
ICC1	Off	Off	X	b	b	Off	Off	X	X	Off	Supply current
ICC2	Off	Off	On	a	b	Off	Off	X	X	Off	Supply current
ICC3	Off	Off	On	b	a	Off	Off	X	X	Off	Supply current
ICC4	Off	Off	On	a	a	Off	Off	X	X	Off	Supply current
IIN	On	On	On	a	a	Off	Off	X	X	Off	Input current
IIK	Off	Off	Off	b	b	Off	Off	X	X	Off	Leakage current
VSF1	On	On	On	a	b	On	On	Off	Off	a	Spark diode
VSF2	On	On	On	b	a	On	On	Off	Off	b	Spark diode
VO1A	On	On	On	a	b	On	On	On	On	Off	Single mode
VO2A	On	On	On	b	a	On	On	On	On	Off	Single mode
VO3A	On	On	On	a	b	On	On	On	On	Off	Single mode
VO4A	On	On	On	b	a	On	On	On	On	Off	Single mode
VO5	On	On	On	a	b	On	On	On	On	Off	Parallel mode
VO6	On	On	On	b	a	On	On	On	On	Off	Parallel mode
VO7	On	On	On	a	b	On	On	On	On	Off	Parallel mode
VO8	On	On	On	b	a	On	On	On	On	Off	Parallel mode
VSUS	Off	Off	X	b	b	On	On	On	On	Off	Sustain voltage

Notes:

' X ' : Don't care.

Typical Application Circuits 1

(Single drive mode)

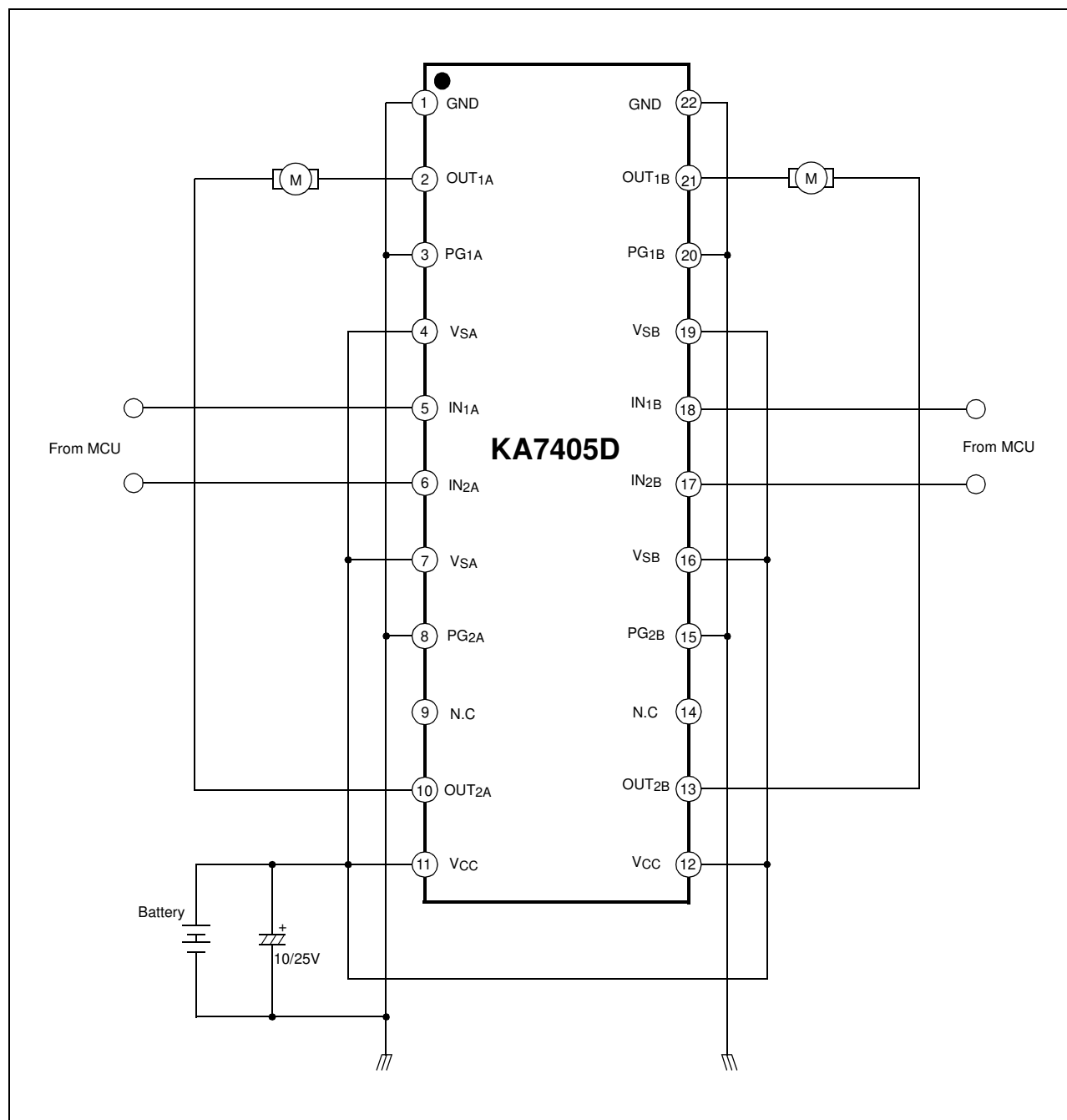

Typical Application Circuits 2

(Parallel drive mode)

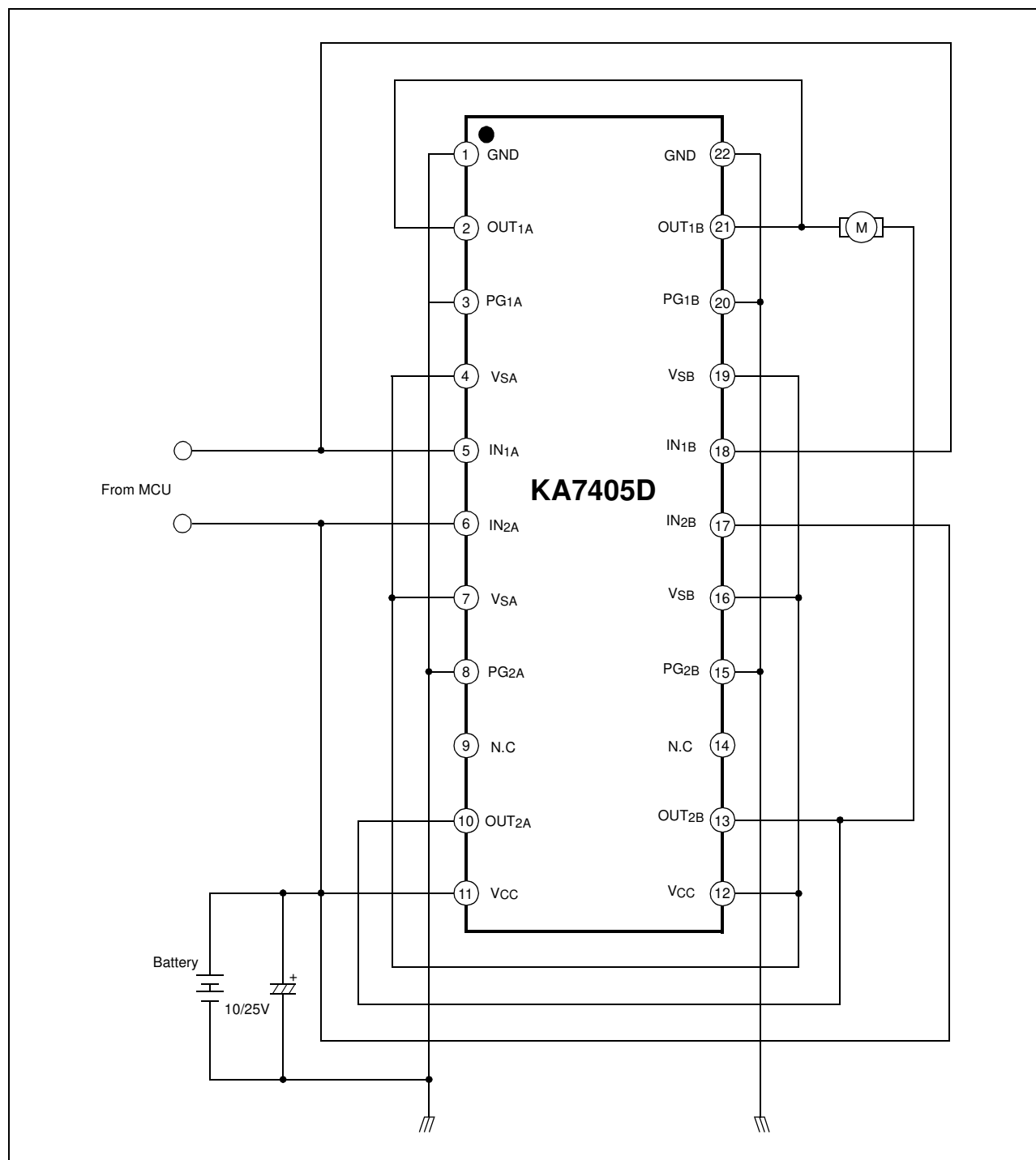

DISCLAIMER

FAIRCHILD SEMICONDUCTOR RESERVES THE RIGHT TO MAKE CHANGES WITHOUT FURTHER NOTICE TO ANY PRODUCTS HEREIN TO IMPROVE RELIABILITY, FUNCTION OR DESIGN. FAIRCHILD DOES NOT ASSUME ANY LIABILITY ARISING OUT OF THE APPLICATION OR USE OF ANY PRODUCT OR CIRCUIT DESCRIBED HEREIN; NEITHER DOES IT CONVEY ANY LICENSE UNDER ITS PATENT RIGHTS, NOR THE RIGHTS OF OTHERS.

LIFE SUPPORT POLICY

FAIRCHILD'S PRODUCTS ARE NOT AUTHORIZED FOR USE AS CRITICAL COMPONENTS IN LIFE SUPPORT DEVICES OR SYSTEMS WITHOUT THE EXPRESS WRITTEN APPROVAL OF THE PRESIDENT OF FAIRCHILD SEMICONDUCTOR INTERNATIONAL. As used herein:

1. Life support devices or systems are devices or systems which, (a) are intended for surgical implant into the body, or (b) support or sustain life, and (c) whose failure to perform when properly used in accordance with instructions for use provided in the labeling, can be reasonably expected to result in a significant injury of the user.
2. A critical component in any component of a life support device or system whose failure to perform can be reasonably expected to cause the failure of the life support device or system, or to affect its safety or effectiveness.

Fairchild Semiconductor

SEARCH | Parametric | Cross Reference

space Product Folders and Applies

find products

Home >> Find products >>

Products groups

Analog and Mixed

Signal

Discrete

Interface

Logic

Microcontrollers

Non-Volatile

Memory

Optoelectronics

Markets and

applications

New products

Product selection and

parametric search

Cross-reference

search

KA7405D
DC Motor Driver

Contents

[General description](#) | [Features](#) | [Applications](#) | [Product status/pricing/packaging](#)

General description

The KA7405D is a monolithic integrated circuit, suitable for the zoom and reel motor driver for camera, tape deck, any other consumer and industrial applications.

[back to top](#)

Features

- Output current up to 1.5A (Each channel).
- 4-function modes (CW, CCW, stop and brake) are controlled by 2-logic circuits.
- Operating voltage range: $V_{CC} = 2.5 \sim 6.0V$.
- Built-in spike killer diode.
- Low saturation voltage.

[back to top](#)

Applications

- Camera zoom and film motors
- General DC motor

[back to top](#)

Product status/pricing/packaging

Related Links

[Request samples](#)

[Dotted line](#)
[How to order products](#)

[Dotted line](#)
[Product Change Notices \(PCNs\)](#)

[Dotted line](#)
[Support](#)

[Dotted line](#)
[Distributor and field sales representatives](#)

[Dotted line](#)
[Quality and reliability](#)

[Dotted line](#)
[Design tools](#)

Datasheet

[Download this datasheet](#)

PDF

[e-mail this datasheet](#)

[E-]

This page [Print version](#)

technical information

buy products

technical support

my Fairchild

company

Product	Product status	Package type	Leads	Packing method
KA7405D01	Not recommended for new designs	SOP	22	RAIL
KA7405D	Not recommended for new designs	SOP	22	RAIL

[back to top](#)

[Home](#) | [Find products](#) | [Technical information](#) | [Buy products](#) |
[Support](#) | [Company](#) | [Contact us](#) | [Site index](#) | [Privacy policy](#)

[© Copyright 2002 Fairchild Semiconductor](#)
