

## ISL88694

### SMBus Accelerator (SMA)

FN8239  
Rev.2.00  
Jan 25, 2019

The [ISL88694](#) SMBus accelerator (SMA) is a dual active pull-up bus terminator designed to improve data transmission speed on SMBus or similar 2-wire serial bus interfaces. The ISL88694 is also compatible with the I<sup>2</sup>C serial bus.

The SMA detects rising input transitions with two internal voltage references and two comparators per channel. After the voltage on a data line crosses the first threshold ( $V_{TRIPL}$ ), the boost pull-up current source is activated to speed transition. After the voltage crosses the second threshold ( $V_{TRIPH}$ ), the boost pull-up current source is deactivated, leaving an active pull-up current of 275 $\mu$ A on the line. When both channels are HIGH, the pull-up current for both lines is reduced to 100 $\mu$ A to save power. Internal logic ensures that the active and boost pull-up current sources are not activated during downward transitions.

The level for  $V_{TRIPH}$  is controlled by a bandgap voltage referred to  $V_{DD}$ . This feature makes the switching behavior invariant for all power supply voltages between 2.7V and 5.5V.

A noise filter on each channel prevents the circuit from responding to input transitions that do not exceed a voltage-time threshold. To activate the boost circuit, the input must exceed  $V_{TRIPL}$  by 100Vns (typical) (See Figure 10).

The SMA permits operation of the bus at frequencies up to 100kHz, despite the capacitive loads of multiple devices and/or long PC board traces. Enhanced ESD protection on the accelerator pins are guaranteed to withstand 8kV ESD (HBM) events.

The SMBus Accelerator provides an essential function in SMBus applications because of distributed capacitance of SMBus and multiple device input capacitances at various nodes. By incorporating SMA, systems using SMBus or I<sup>2</sup>C can reliably increase their bus load without the risk of data loss.

### Features

- Active termination for SMBus lines
- Enhances system bus signal rise time
- Increases bus capacity while ensuring data integrity
- 2.2mA rise time supply current
- 8kV ESD protection on SDA and SCL pins
- Wide operating voltage range: 2.7V to 5.5V
- 2-Wire SMBus and I<sup>2</sup>C compatible (100kHz)
- Small package - SOT23-5
- Pin-for-pin compatible with the LTC1694
- Pb-free available (RoHS compliant)

### Target Applications

- Servers
- Data acquisition
- Routers
- Battery chargers
- Portable instrumentation
- Notebook
- PC
- Facilities tracking system

### Related Literature

For a full list of related documents, visit our website:

- [ISL88694](#) device page

## Ordering Information

PART NUMBER (Notes 2, 3)	PART MARKING (Note 4)	TEMP RANGE (°C)	TAPE AND REEL (Units) (Note 1)	PACKAGE (RoHS Compliant)	PKG. DWG. #
ISL88694IH5Z-TK	AKM	-40 to +85	1k	5-pin SOT	P5.064

### NOTES:

- See [TB347](#) for details about reel specifications.
- Pb-free products employ special Pb-free material sets; molding compounds/die attach materials and 100% matte tin plate termination finish, which are RoHS compliant and compatible with both SnPb and Pb-free soldering operations. Pb-free products are MSL classified at Pb-free peak reflow temperatures that meet or exceed the Pb-free requirements of IPC/JEDEC J STD-020.
- For Moisture Sensitivity Level (MSL), see the [ISL88694](#) device page. For more information about MSL, see [TB363](#).
- The part marking is located on the bottom of the part.

## Pinout

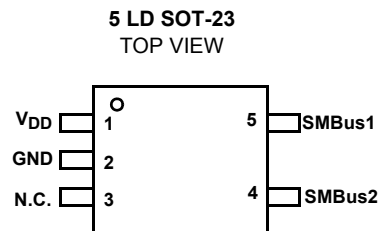

## Pin Descriptions

SOT-23	SYMBOL	DESCRIPTION
1	V <sub>DD</sub>	Supply Voltage
2	GND	Ground
3	N.C.	No Connect
4	SMBus2	Active Pull-Up for SMBus
5	SMBus1	Active Pull-Up for SMBus

## System Diagram

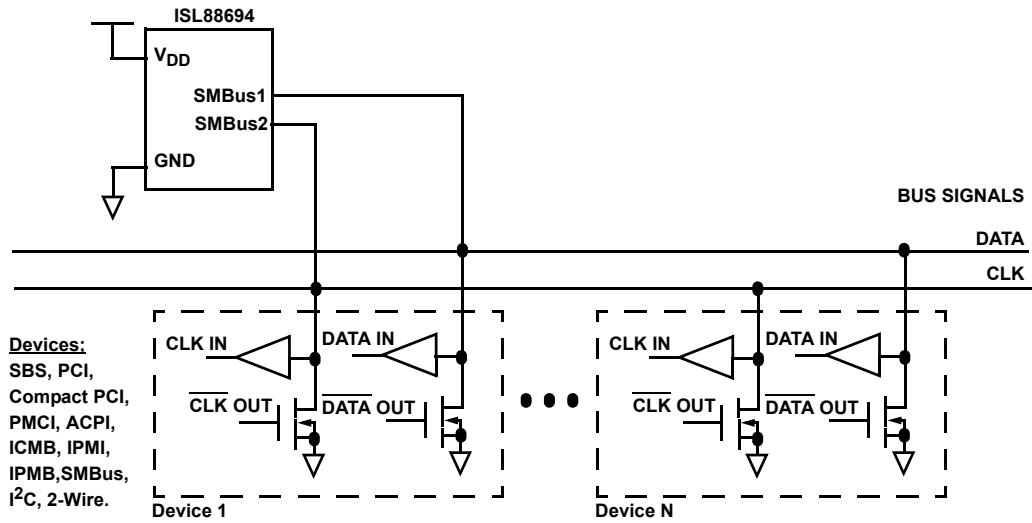

## IC Block Diagram

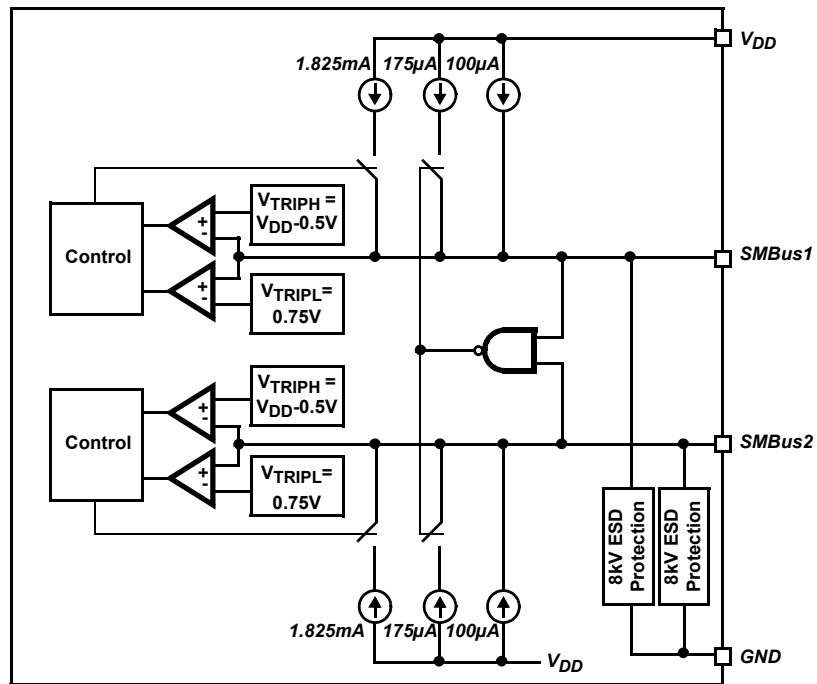

**Absolute Maximum Ratings**

Supply Voltage Range	-1V to 6.5V
Operating Junction Temperature	+135°C
Storage Temperature Range	-65°C to +150°C
Voltage on pins	-0.3V to $V_{DD}+0.3V$
Lead temperature (soldering, 10 seconds)	300°C
ESD min other pins (HBM)	>2kV
ESD SMBus1 and SMBus2 pins (HBM)	>8kV

**Recommended Operating Conditions**

Temperature	-40°C to +85°C
Supply Voltage	2.7V to 5.5V

*CAUTION: Absolute Maximum Ratings indicate limits beyond which permanent damage to the device and impaired reliability can occur. These are stress ratings provided for information only and functional operation of the device at these or any other conditions beyond those indicated in the operational sections of this specification are not implied.*

*For assured specifications and test conditions, see Electrical Specifications. The assured specifications apply only for the test conditions listed. Some performance characteristics may degrade when the device is not operated under the listed test conditions.*

**Electrical Specifications** Over operating conditions unless otherwise specified, Typical values are measured at  $V_{DD} = 3.3V$  and  $T_A = +25^\circ C$

PARAMETER	SYMBOL	CONDITIONS	MIN	TYP	MAX	UNIT
<b>ANALOG PARAMETERS</b>						
Supply Voltage Range	$V_{DD}$		2.7		5.5	V
$V_{DD}$ Ramp Rate	$V_{DD\ RAMP}$		0.05		50	V/msec
Supply Current	$I_{DD}$	SMBus1 = SMBus2 = Open		80	100	$\mu A$
Standby Pull-Up Current	$I_{OUT\_SB}$	SMBus1 = SMBus2 = $V_{DD}-1.0V$		80	125	$\mu A$
Active Pull-Up Current	$I_{OUT\_A1}$	SMBus1 = GND; SMBus2 = Open	125	275	350	$\mu A$
	$I_{OUT\_A2}$	SMBus1 = Open; SMBus2 = GND	125	275	350	$\mu A$
Boost Pull-Up Current (Figure 1)	$I_{OUT\_B1}$	$V_{TRIPL} < SMBus1 < V_{TRIPH}$ , SMBus2 = Open	1.6	2.2		mA
	$I_{OUT\_B2}$	$V_{TRIPL} < SMBus2 < V_{TRIPH}$ , SMBus1 = Open	1.6	2.2		mA
Input Voltage Threshold Low	$V_{TRIPL}$		0.65	0.75	0.85	V
Input Voltage Threshold High	$V_{TRIPH}$		$V_{DD}-0.60$	$V_{DD} - 0.50$	$V_{DD} - 0.40$	V
SMBus Max Frequency	$f_{MAX}$				100	kHz
Noise Spike Suppression (Note 5) (Figure 10)	NSS			20		V-nsec

## NOTES:

5. Measured as area under triangular waveform above  $V_{TRIPL}$ , with time as base and  $V_{IN}$  as height (see Figure 10 on page 7).

**Typical Performance Curves**

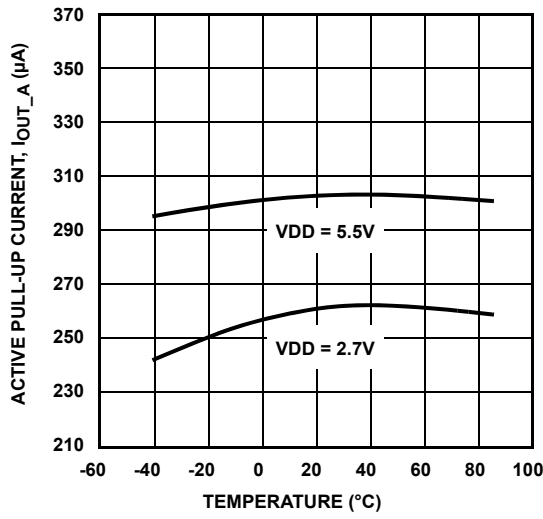

FIGURE 1. ACTIVE PULL-UP CURRENT, SMBus PIN = 0V

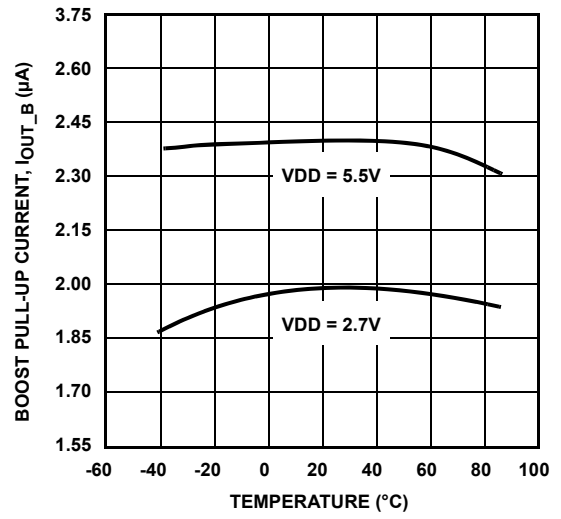

FIGURE 2. BOOST PULL-UP CURRENT, SMBus PIN = V<sub>DD</sub>/2

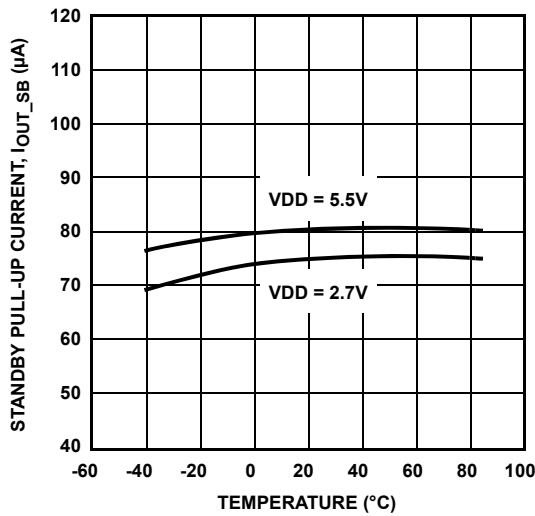

FIGURE 3. STANDBY PULL-UP CURRENT, SMBus1, 2 = V<sub>DD</sub>-0.5V

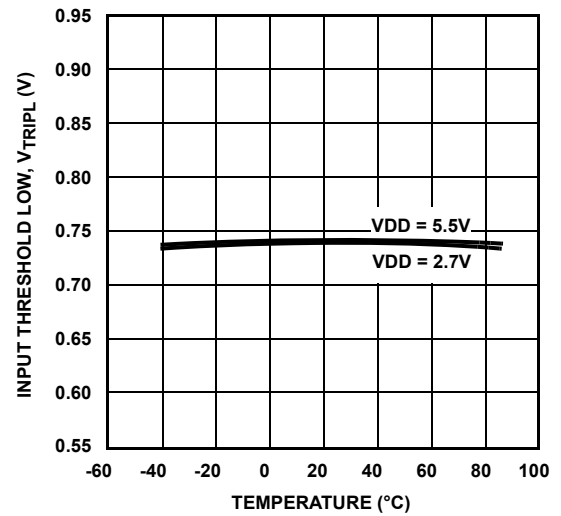

FIGURE 4. V<sub>TRIPL</sub> VOLTAGE

**Typical Performance Curves** (Continued)

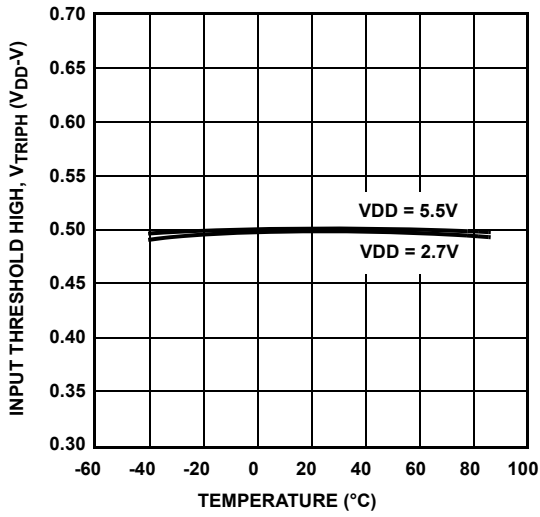

FIGURE 5. V<sub>TRIPH</sub> VOLTAGE

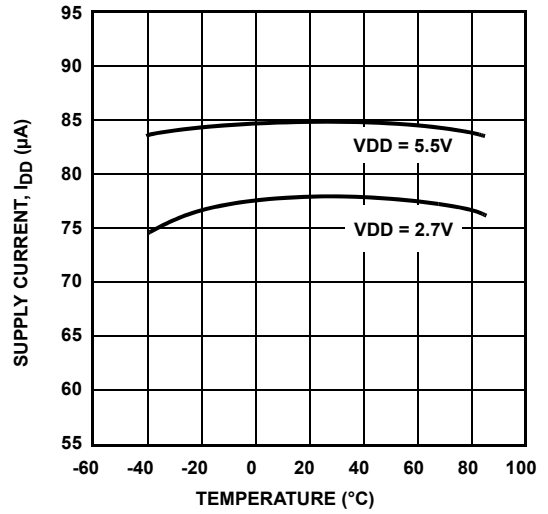

FIGURE 6. I<sub>DD</sub> CURRENT. SMBus1 = SMBus2 = OPEN

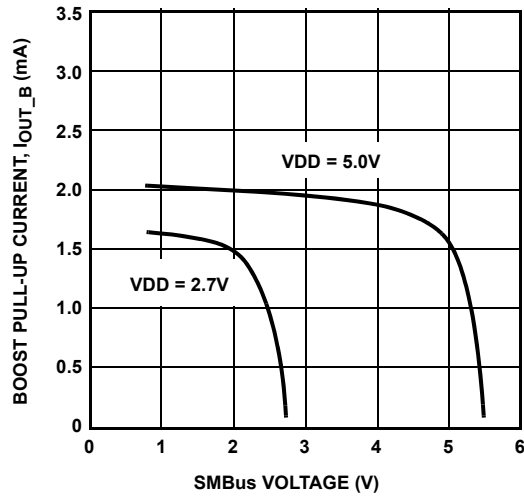

FIGURE 7. BOOST PULL-UP CURRENT vs SMBus VOLTAGE

## Functional Description

### SMBus Overview

The SMBus or I<sup>2</sup>C bus is a 2-wire multimaster bus, meaning that more than one device connected to the bus is capable of controlling it. Master devices communicate to other master or slave devices using one clock and one data line. These are both bidirectional.

To allow multimaster operation without bus contention, it is necessary to allow each bus to be connected to a positive supply voltage through a current-source or pull-up resistor (see “System Diagram” on page 3). When the bus is free, both lines are HIGH. The output stages of devices connected to the bus must have an open-drain or open-collector to perform the wired-AND function.

Simple pull-up resistors on the clock and data lines work well unless there are long signal lines or many devices connected to the bus. Then, the combined capacitance of the bus increases the rise time on the signal so much that the communication becomes unreliable or fails to meet the bus timing specifications. Smaller resistors can sometimes compensate for the extra capacitance, but this increases the current consumption when the signal lines are pulled LOW.

### ISL88694 Operation

To improve the operation of the SMBus where larger bus capacitance exists, the ISL88694 provides active pull-up using switched current sources. When the bus is idle and both lines are HIGH, a standby pull-up current of 100µA is used to maintain the signal level while minimizing power consumption. When either of the two signals is pulled LOW, an active pull-up current of 275µA maintains a good V<sub>OL</sub> noise margin.

When the bus line is released, it is pulled high by the ISL88694 active current until the voltage exceeds the V<sub>TRIPL</sub> level for a period of time. This voltage-time combination filters out noise on the signal line. When the ISL88694 detects a valid rising edge, a 2.2mA boost current pulls the bus line high very quickly (see Figure 8). This boost current turns off when the input level reaches the V<sub>TRIPH</sub> threshold and the pull-up current returns to the active level. If both inputs are HIGH, the pull-up current drops to the standby level of 100µA.

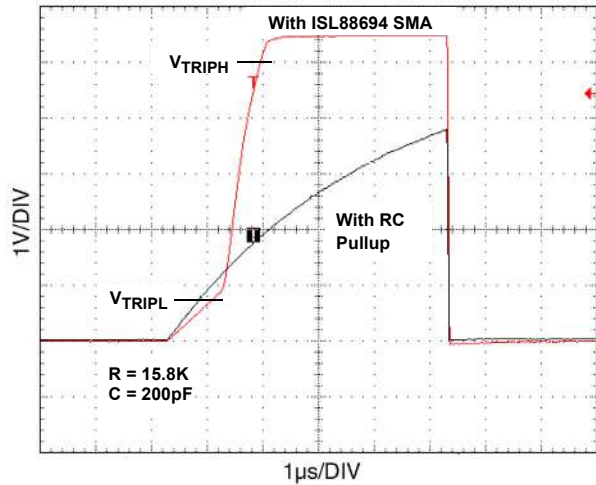

FIGURE 8. ISL88694 SMBus SYSTEM BOOST PULL-UP COMPARED TO RESISTOR PULL-UP (V<sub>DD</sub> = 5.5V)

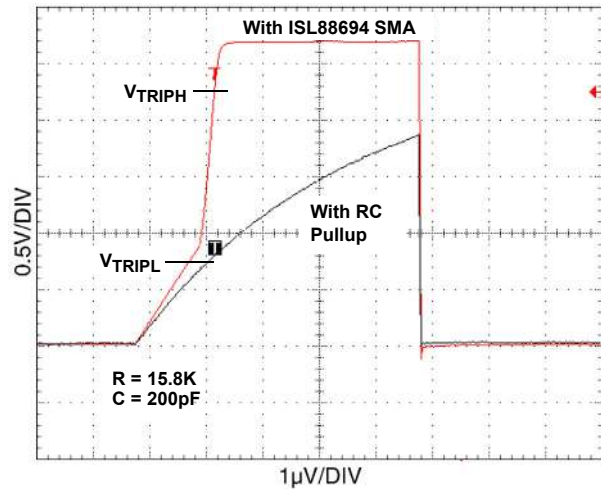

FIGURE 9. ISL88694 SMBus SYSTEM BOOST PULL-UP COMPARED TO RESISTOR PULL-UP (V<sub>DD</sub> = 2.7V)

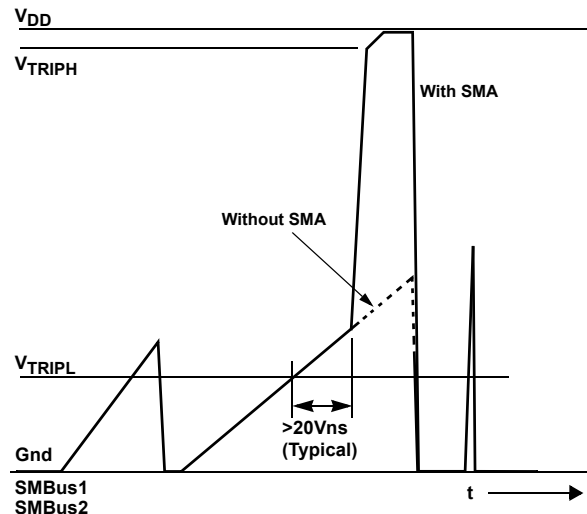

FIGURE 10. NOISE SUPPRESSION. BOOST CURRENT APPLIED WHEN INPUT SIGNAL EXCEEDS 20Vns (TYPICAL)

---

**Revision History** The revision history provided is for informational purposes only and is believed to be accurate, but not warranted. Please visit our website to make sure you have the latest revision.

DATE	REVISION	CHANGE
Jan 25, 2019	FN8239.2	Added Related Literature section Updated the ordering information by removing parts, adding more columns, updating and adding applicable notes. Updated POD to the correct information. Added Revision History section Updated disclaimer.



**Package Outline Drawing**

For the most recent package outline drawing, see [P5.064](#).

P5.064  
 5 LEAD SMALL OUTLINE TRANSISTOR PLASTIC PACKAGE  
 Rev 3, 4/11

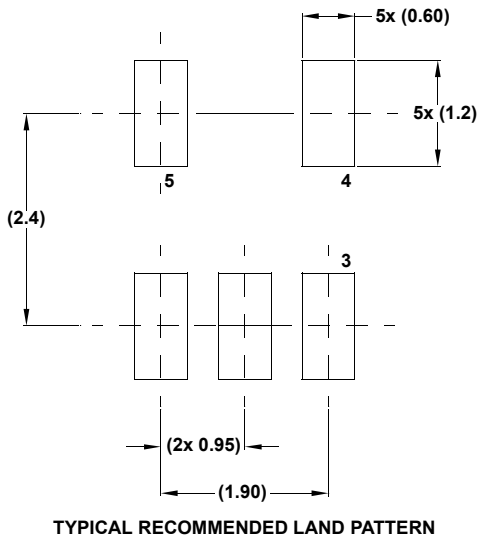
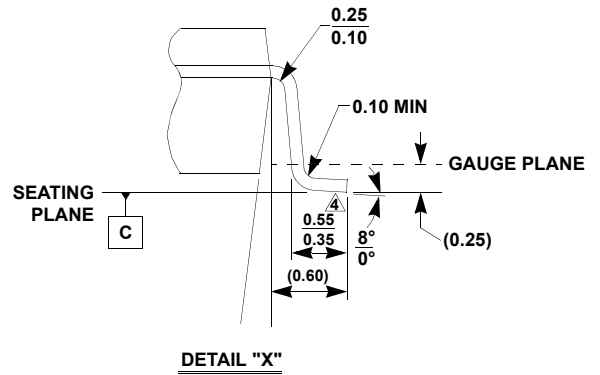
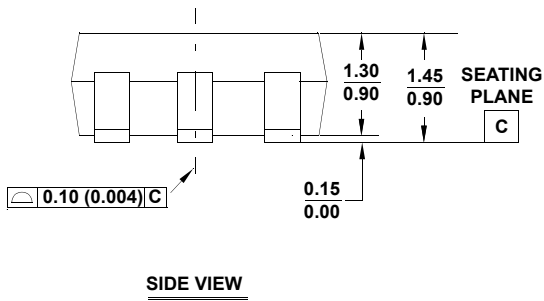
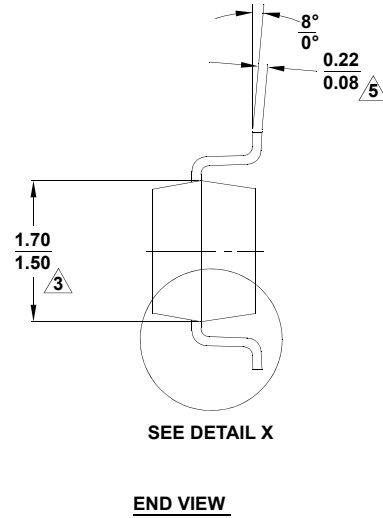
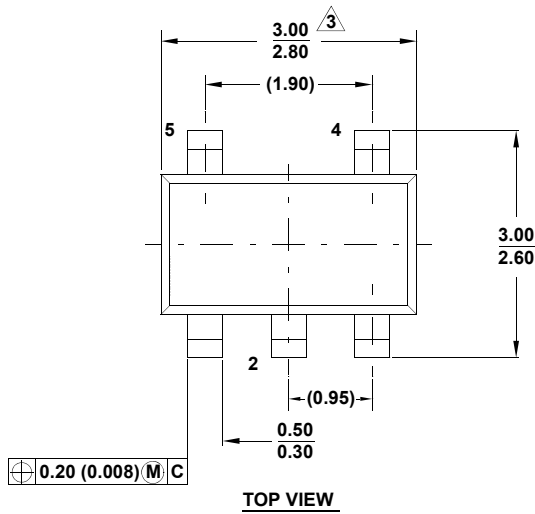

**NOTES:**

1. Dimensioning and tolerance per ASME Y14.5M-1994.
2. Package conforms to EIAJ SC-74 and JEDEC MO178AA.
3. Package length and width are exclusive of mold flash, protrusions, or gate burrs.
4. Footlength measured at reference to gauge plane.
5. Lead thickness applies to the flat section of the lead between 0.08mm and 0.15mm from the lead tip.
6. Controlling dimension: MILLIMETER.  
 Dimensions in ( ) for reference only.

## Notice

1. Descriptions of circuits, software and other related information in this document are provided only to illustrate the operation of semiconductor products and application examples. You are fully responsible for the incorporation or any other use of the circuits, software, and information in the design of your product or system. Renesas Electronics disclaims any and all liability for any losses and damages incurred by you or third parties arising from the use of these circuits, software, or information.
  2. Renesas Electronics hereby expressly disclaims any warranties against and liability for infringement or any other claims involving patents, copyrights, or other intellectual property rights of third parties, by or arising from the use of Renesas Electronics products or technical information described in this document, including but not limited to, the product data, drawings, charts, programs, algorithms, and application examples.
  3. No license, express, implied or otherwise, is granted hereby under any patents, copyrights or other intellectual property rights of Renesas Electronics or others.
  4. You shall not alter, modify, copy, or reverse engineer any Renesas Electronics product, whether in whole or in part. Renesas Electronics disclaims any and all liability for any losses or damages incurred by you or third parties arising from such alteration, modification, copying or reverse engineering.
  5. Renesas Electronics products are classified according to the following two quality grades: "Standard" and "High Quality". The intended applications for each Renesas Electronics product depends on the product's quality grade, as indicated below.
    - "Standard": Computers; office equipment; communications equipment; test and measurement equipment; audio and visual equipment; home electronic appliances; machine tools; personal electronic equipment; industrial robots; etc.
    - "High Quality": Transportation equipment (automobiles, trains, ships, etc.); traffic control (traffic lights); large-scale communication equipment; key financial terminal systems; safety control equipment; etc.Unless expressly designated as a high reliability product or a product for harsh environments in a Renesas Electronics data sheet or other Renesas Electronics document, Renesas Electronics products are not intended or authorized for use in products or systems that may pose a direct threat to human life or bodily injury (artificial life support devices or systems; surgical implantations; etc.), or may cause serious property damage (space system; undersea repeaters; nuclear power control systems; aircraft control systems; key plant systems; military equipment; etc.). Renesas Electronics disclaims any and all liability for any damages or losses incurred by you or any third parties arising from the use of any Renesas Electronics product that is inconsistent with any Renesas Electronics data sheet, user's manual or other Renesas Electronics document.
  6. When using Renesas Electronics products, refer to the latest product information (data sheets, user's manuals, application notes, "General Notes for Handling and Using Semiconductor Devices" in the reliability handbook, etc.), and ensure that usage conditions are within the ranges specified by Renesas Electronics with respect to maximum ratings, operating power supply voltage range, heat dissipation characteristics, installation, etc. Renesas Electronics disclaims any and all liability for any malfunctions, failure or accident arising out of the use of Renesas Electronics products outside of such specified ranges.
  7. Although Renesas Electronics endeavors to improve the quality and reliability of Renesas Electronics products, semiconductor products have specific characteristics, such as the occurrence of failure at a certain rate and malfunctions under certain use conditions. Unless designated as a high reliability product or a product for harsh environments in a Renesas Electronics data sheet or other Renesas Electronics document, Renesas Electronics products are not subject to radiation resistance design. You are responsible for implementing safety measures to guard against the possibility of bodily injury, injury or damage caused by fire, and/or danger to the public in the event of a failure or malfunction of Renesas Electronics products, such as safety design for hardware and software, including but not limited to redundancy, fire control and malfunction prevention, appropriate treatment for aging degradation or any other appropriate measures. Because the evaluation of microcomputer software alone is very difficult and impractical, you are responsible for evaluating the safety of the final products or systems manufactured by you.
  8. Please contact a Renesas Electronics sales office for details as to environmental matters such as the environmental compatibility of each Renesas Electronics product. You are responsible for carefully and sufficiently investigating applicable laws and regulations that regulate the inclusion or use of controlled substances, including without limitation, the EU RoHS Directive, and using Renesas Electronics products in compliance with all these applicable laws and regulations. Renesas Electronics disclaims any and all liability for damages or losses occurring as a result of your noncompliance with applicable laws and regulations.
  9. Renesas Electronics products and technologies shall not be used for or incorporated into any products or systems whose manufacture, use, or sale is prohibited under any applicable domestic or foreign laws or regulations. You shall comply with any applicable export control laws and regulations promulgated and administered by the governments of any countries asserting jurisdiction over the parties or transactions.
  10. It is the responsibility of the buyer or distributor of Renesas Electronics products, or any other party who distributes, disposes of, or otherwise sells or transfers the product to a third party, to notify such third party in advance of the contents and conditions set forth in this document.
  11. This document shall not be reprinted, reproduced or duplicated in any form, in whole or in part, without prior written consent of Renesas Electronics.
  12. Please contact a Renesas Electronics sales office if you have any questions regarding the information contained in this document or Renesas Electronics products.
- (Note1) "Renesas Electronics" as used in this document means Renesas Electronics Corporation and also includes its directly or indirectly controlled subsidiaries.
- (Note2) "Renesas Electronics product(s)" means any product developed or manufactured by or for Renesas Electronics.

(Rev.4.0-1 November 2017)

## Corporate Headquarters

TOYOSU FORESIA, 3-2-24 Toyosu,  
Koto-ku, Tokyo 135-0061, Japan  
[www.renesas.com](http://www.renesas.com)

## Contact Information

For further information on a product, technology, the most up-to-date version of a document, or your nearest sales office, please visit:  
[www.renesas.com/contact/](http://www.renesas.com/contact/)

## Trademarks

Renesas and the Renesas logo are trademarks of Renesas Electronics Corporation. All trademarks and registered trademarks are the property of their respective owners.