

ISS.	DATE	E.C.N.	DESCRIPTION
2	31-Aug-04	08/04/1160	INCLUSION SPECIFICATION ADDED
3	15-Jan-07	1/07/1198	SCALLOP SIZE INCREASED

© 2007 CARCLO
ALL DIMENSIONS IN mm

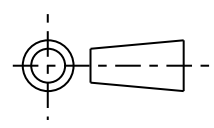

CUSTOMER DRAWING



CARCLO TECHNICAL PLASTICS (SLOUGH) LTD.
111 BUCKINGHAM AVE, SLOUGH
SL1 4PF, ENGLAND
TEL: +44 1753 575011 FAX: +44 1753 811359
e-mail: design@ctpcoil.co.uk}

GENERAL TOLERANCES (UNLESS STATED)

LINEAR	ANGULAR
X +/- 0.25	X +/- 1°
X.X +/- 0.1	X.X +/- 0.5°
X.XX +/- 0.05	X.XX +/- 0.1°

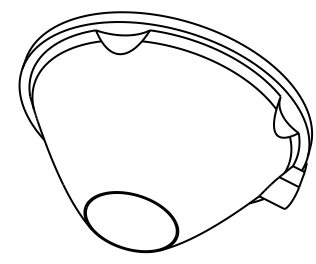
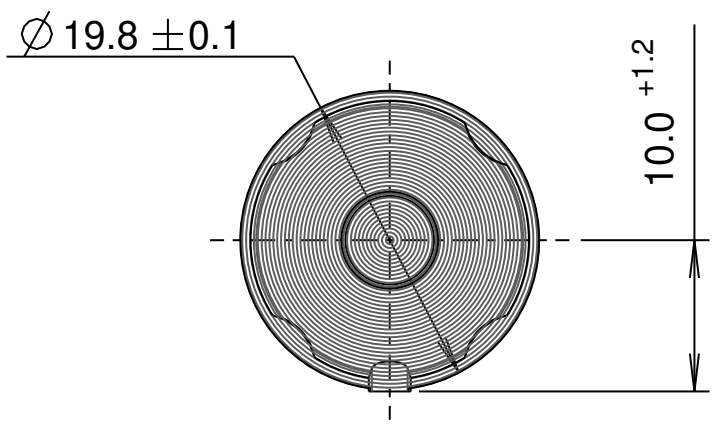

3D VIEW

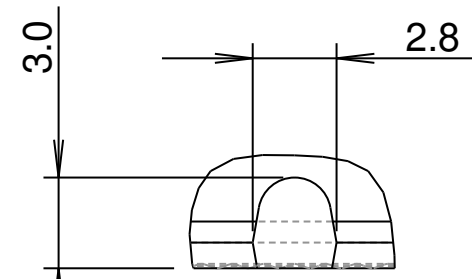
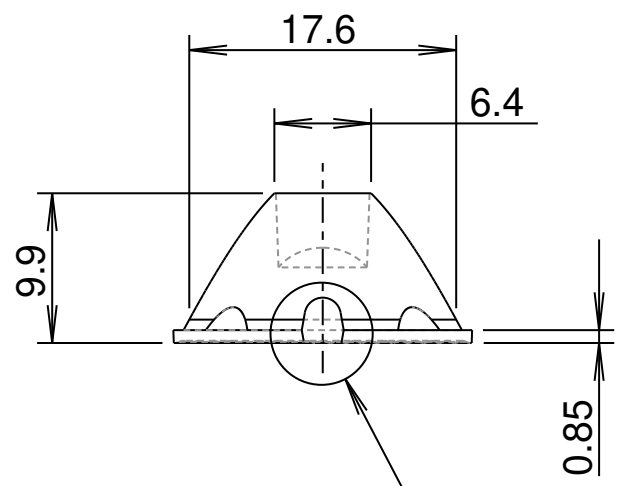

DETAIL A
SCALE 4:1

SEE DETAIL A

CUSTOMER

CARCLO

TITLE

LED Optic 15 Deg Circular

DRAWN

AJD

DATE

31-Aug-04

CHK'D

DATE

APP'D

DATE

SCALE

2:1

COIL PART No.

10003/15

SIZE

A4

COIL DRG. No.

60347

SHEET

1 OF 1