

**DESIGNED AND DIMENSIONED
IN MILLIMETERS [INCHES]**

DO NOT
SCALE FROM
THIS PRINT

QRM8-XXX-XX.X-X-D-XX-A-XX

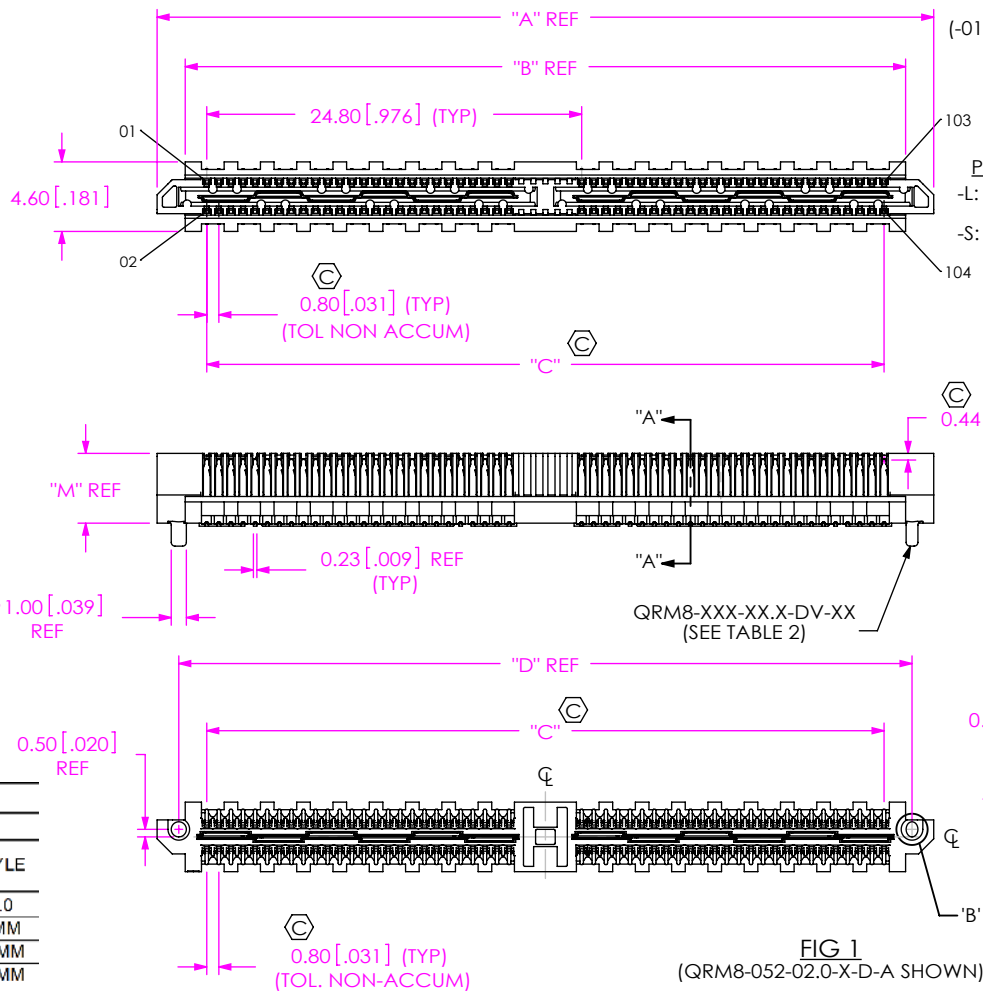

No OF POSITIONS
-026, -052, *-078
(-018, -036, *-054 FOR -DP ONLY)

LEAD STYLE
-02.0 = 2mm (SEE FIG. 1)
-05.0 = 5mm (SEE FIG. 3, SHT 2)
-07.0 = 7mm

PLATING SPECIFICATION
-L: LIGHT SELECTIVE GOLD / MATTE TIN
(USE T-1M53-XX.X-L & T-1G38-XX.X-L)
-S: SELECTIVE GOLD / MATTE TIN
(USE T-1M53-XX.X-S & T-1G38-XX.X-S)

OPTIONS
-K: POLYIMIDE FILM PAD
-TR: TAPE & REEL
(SEE NOTE 4)
-GP: GUIDE POST
(SHEET 3, FIG 4)
(SEE NOTE 8)

OPTIONS
-A: ALIGNMENT PIN

OPTION
(IF NOT APPLICABLE, LEAVE BLANK)
-DP: DIFFERENTIAL PAIRS
(SHEET 4, FIG 5)

ROW SPECIFICATION
-D: DOUBLE

* = NOT AVAILABLE IN -02.0 LEAD STYLE

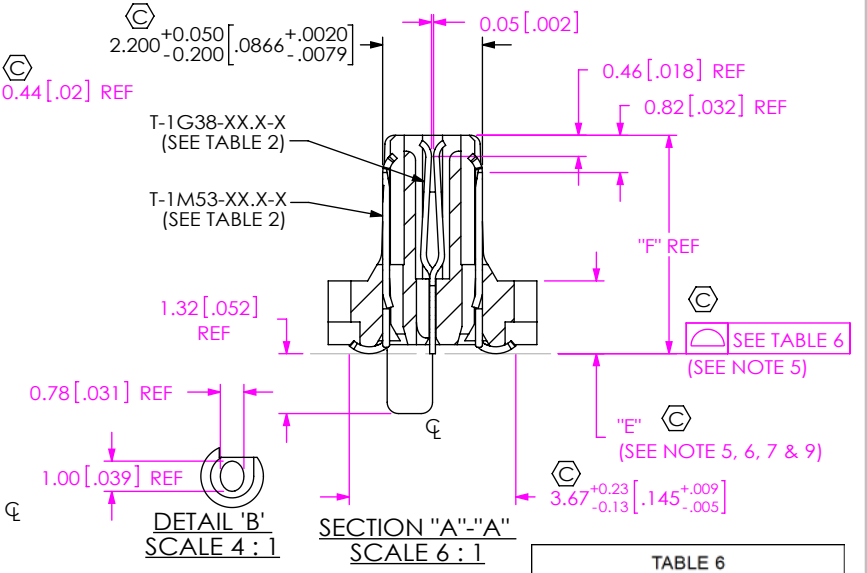

NOTES:

- ⊗ REPRESENTS A CRITICAL DIMENSION.
- MAXIMUM BURR ALLOWANCE: 0.038 [0.015]
- MINIMUM PUSHOUT FORCE: SIGNAL: 1.60 N [4 LB.] ; GROUND PLANE: 4.44 [1LB]
- PARTS TO BE PACKAGED IN TRAYS, UNLESS -TR OPTION IS SPECIFIED.
-054 & -078 POSITION NOT AVAILABLE IN TAPE AND REEL.
- DIMENSION APPLIES TO CONTACTS & GROUND PLANE.
- GROUND PLANE PRESS HEIGHT MUST BE 0.08 [0.003] LESS THAN THE MAX HEIGHT OR 0.03 [0.01] GREATER THAN THE MINIMUM HEIGHT OF THE TERMINAL.
- MAXIMUM VARIANCE OF 0.05 [0.002].
- PARTS WITH THE -GP OPTION MUST MATE TO -GP OPTIONED QRF8 PARTS AND PARTS WITH NO -GP OPTION MUST MATE TO NON -GP OPTIONED QRF8 PARTS.
- NOTE DELETED.

TABLE 1 REF
STACK HEIGHT

QRM8 LEAD STYLE	QRF8 LEAD STYLE	
	-05.0	-07.0
-02.0	7.0MM	9.0MM
-05.0	10.0MM	12.0MM
-07.0	12.0MM	14.0MM

TABLE 2

LEAD STYLE	QRM8-XXX-XX.X-DV-XX	T-1M53-XX.X-X	T-1G38-XX.X-X	"E"	"F"	"M"
-02.0	QRM8-XXX-02.0-DV-XX	T-1M53-02.0-X	T-1G38-02.0-X	1.61 [0.063]	4.81 [0.189]	4.62 [0.182]
-05.0	QRM8-XXX-05.0-DV-XX	T-1M53-05.0-X	T-1G38-05.0-X	4.61 [0.181]	7.81 [0.307]	7.62 [0.300]
-07.0	QRM8-XXX-07.0-DV-XX	T-1M53-07.0-X	T-1G38-07.0-X	6.61 [0.260]	9.78 [0.385]	9.62 [0.379]

TABLE 6

No OF POSITIONS	
-018, -026	0.10 [0.004]
-036, -052, -054, -078	0.15 [0.006]

TABLE 3

No OF POSITIONS	"A"	"B"	"C"	"D"
-018, -026	26.57 [1.046]	22.85 [0.900]	20.00 [0.787]	23.70 [0.933]
-036, -052	51.37 [2.022]	47.65 [1.876]	44.80 [1.764]	48.50 [1.909]
*-054, *-078	76.17 [2.999]	72.45 [2.852]	69.60 [2.740]	73.30 [2.886]

* = NOT AVAILABLE IN 02.0 LEAD STYLE

UNLESS OTHERWISE SPECIFIED, DIMENSIONS ARE IN MILLIMETERS [INCHES].
TOLERANCES ARE:
DECIMALS ANGLES
X.X: ±0.3 [01] 2°
X.XX: ±0.13 [005]
X.XXX: ±0.050 [0020]

PROPRIETARY NOTE
THIS DOCUMENT CONTAINS CONFIDENTIAL AND PROPRIETARY INFORMATION AND ALL DESIGN, MANUFACTURING, REPRODUCTION, USE, PATENT RIGHTS AND SALES RIGHTS ARE EXPRESSLY RESERVED BY SAMTEC, INC. THIS DOCUMENT SHALL NOT BE DISCLOSED, IN WHOLE OR PART, TO ANY UNAUTHORIZED PERSON OR ENTITY NOR REPRODUCED, TRANSFERRED OR INCORPORATED IN ANY OTHER PROJECT IN ANY MANNER WITHOUT THE EXPRESS WRITTEN CONSENT OF SAMTEC, INC.



520 PARK EAST BLVD, NEW ALBANY, IN 47150
PHONE: 812-944-6733 FAX: 812-948-5047
e-Mail info@SAMTEC.com code 55322

MATERIAL: DO NOT SCALE DRAWING SHEET SCALE: 2:1
INSULATOR: LCP, COLOR: BLACK
TERMINAL & GROUND PLANE: PHOS. BRZ.

DESCRIPTION:
.8MM Q-RATE TERMINAL ASSEMBLY
DWG. NO.

QRM8-XXX-XX.X-X-D-XX-A-XX

BY: CLAY W 8/27/2008 SHEET 1 OF 4

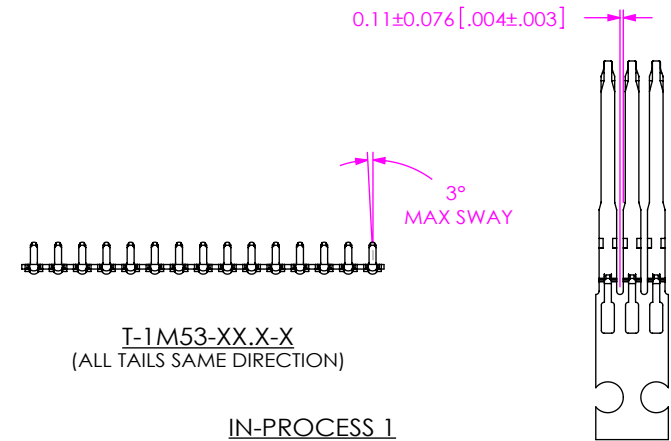
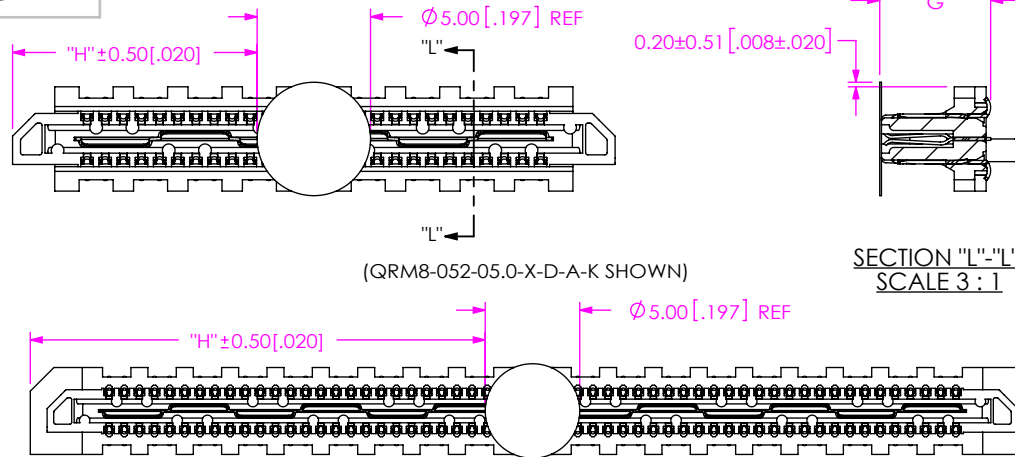

LEADSTYLE	POSITION	"H"
-02.0	-018, -026	10.78 [.424]
	-036, -052	23.18 [.913]
-02.0 W/-GP	-018, -026	11.68 [.460]
	-036, -052	24.08 [.948]
-05.0 & -07.0	-018, -026	11.68 [.460]
	-036, -052	24.08 [.948]
	-054, -078	36.48 [1.436]

LEAD STYLE	"G"
-02.0	4.94 [0.194]
-05.0	7.94 [0.313]
-07.0	9.94 [0.391]

FIG 2
-K OPTION
(USE K-DOT-.197-.344-.005)
(QRM8-026-02.0-X-D-A-K SHOWN)

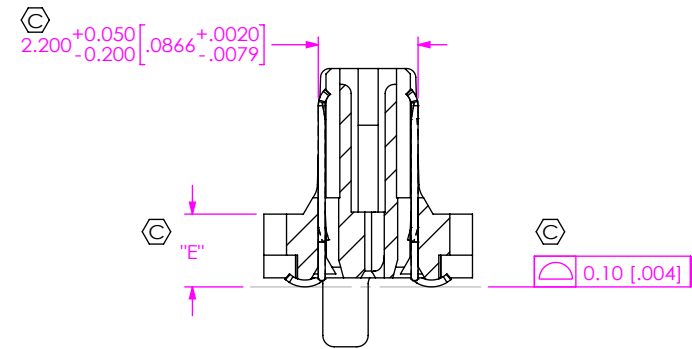

IN-PROCESS 2
FILL T-1M53-XX.X-X TERMINALS

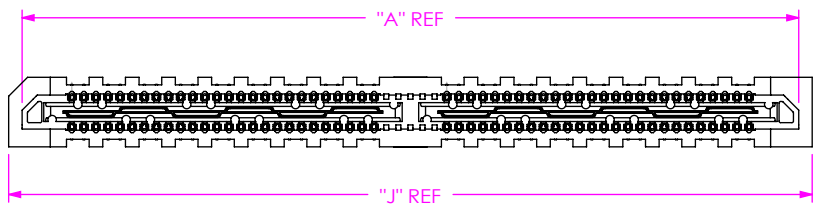

POSITION	"J"
-018, -026	28.35 [1.116]
-036, -052	53.15 [2.093]
*-054, *-078	77.95 [3.069]

* = NOT AVAILABLE IN -02.0 LEAD STYLE

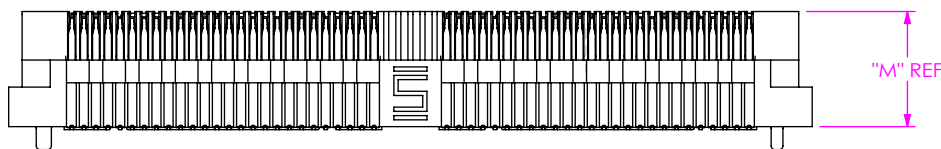

FIG 3
(QRM8-052-05.0-X-D-A SHOWN)
(SAME AS FIG 1 EXCEPT AS SHOWN)

PROPRIETARY NOTE
THIS DOCUMENT CONTAINS CONFIDENTIAL AND PROPRIETARY INFORMATION AND ALL DESIGN, MANUFACTURING, REPRODUCTION, USE, PATENT RIGHTS AND SALES RIGHTS ARE EXPRESSLY RESERVED BY SAMTEC, INC. THIS DOCUMENT SHALL NOT BE DISCLOSED, IN WHOLE OR PART, TO ANY UNAUTHORIZED PERSON OR ENTITY NOR REPRODUCED, TRANSFERRED OR INCORPORATED IN ANY OTHER PROJECT IN ANY MANNER WITHOUT THE EXPRESS WRITTEN CONSENT OF SAMTEC, INC.

DO NOT SCALE DRAWING

SHEET SCALE: 2:1



520 PARK EAST BLVD, NEW ALBANY, IN 47150
PHONE: 812-944-6733 FAX: 812-948-5047
e-Mail info@SAMTEC.com code 55322

DESCRIPTION:
.8MM Q-RATE TERMINAL ASSEMBLY

DWG. NO.
QRM8-XXX-XX.X-X-D-XX-A-XX

BY: CLAY W 8/27/2008 SHEET 2 OF 4

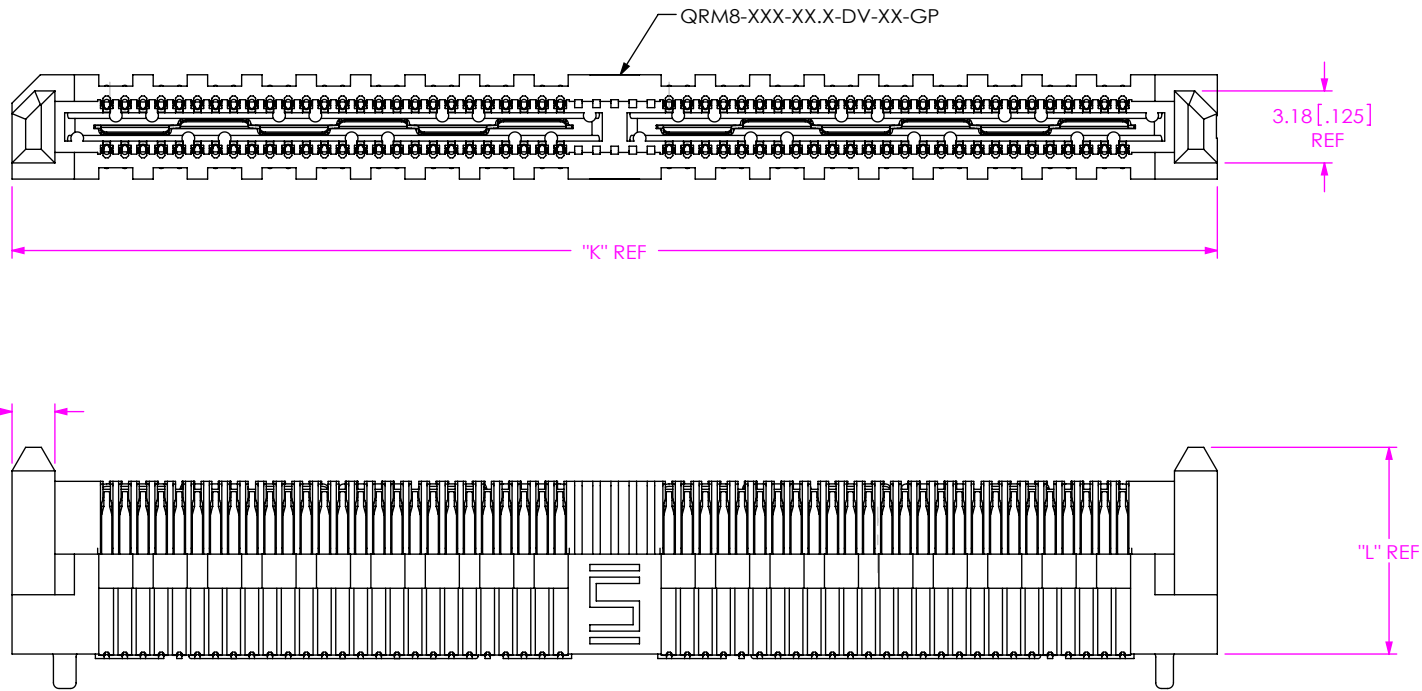

FIG 4
(QRM8-052-05.0-X-D-A-GP SHOWN)
(SAME AS FIG 2 EXCEPT AS SHOWN)

TABLE 8	
POSITION	"K"
-018, -026	28.35 [1.116]
-036, -052	53.15 [2.093]
*-054, *-078	77.95 [3.069]

* = NOT AVAILABLE IN -02.0 LEADSTYLE

TABLE 9	
LEAD STYLE	"L"
-02.0	6.12 [0.241]
-05.0	9.12 [0.359]
-07.0	11.12 [0.438]

PROPRIETARY NOTE
THIS DOCUMENT CONTAINS CONFIDENTIAL AND PROPRIETARY INFORMATION AND ALL DESIGN, MANUFACTURING, REPRODUCTION, USE, PATENT RIGHTS AND SALES RIGHTS ARE EXPRESSLY RESERVED BY SAMTEC, INC. THIS DOCUMENT SHALL NOT BE DISCLOSED, IN WHOLE OR PART, TO ANY UNAUTHORIZED PERSON OR ENTITY NOR REPRODUCED, TRANSFERRED OR INCORPORATED IN ANY OTHER PROJECT IN ANY MANNER WITHOUT THE EXPRESS WRITTEN CONSENT OF SAMTEC, INC.

DO NOT SCALE DRAWING

SHEET SCALE: 3:1



520 PARK EAST BLVD, NEW ALBANY, IN 47150
PHONE: 812-944-6733 FAX: 812-948-5047
e-Mail info@SAMTEC.com code 55322

DESCRIPTION: .8MM Q-RATE TERMINAL ASSEMBLY

DWG. NO. QRM8-XXX-XX.X-X-D-XX-A-XX

BY: CLAY W 8/27/2008 SHEET 3 OF 4

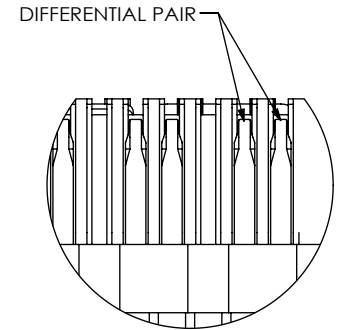
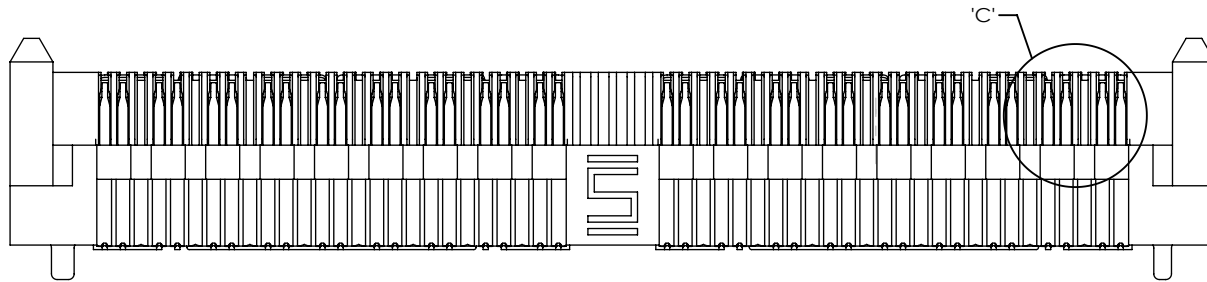
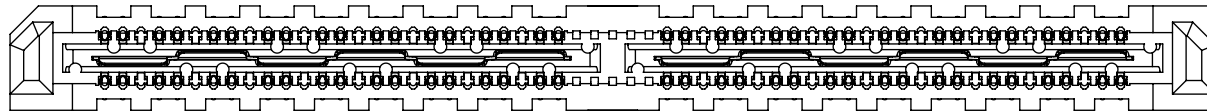

DETAIL 'C'
SCALE 6 : 1

FIG 5
(QRM8-036-05.0-X-D-DP-A-GP SHOWN)
(SAME AS FIG 4 EXCEPT AS SHOWN)

0.11 ± 0.076 [.004 ± .003]
(TYP)

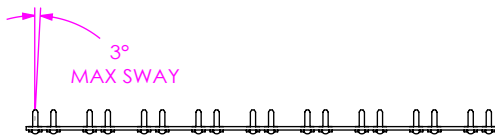
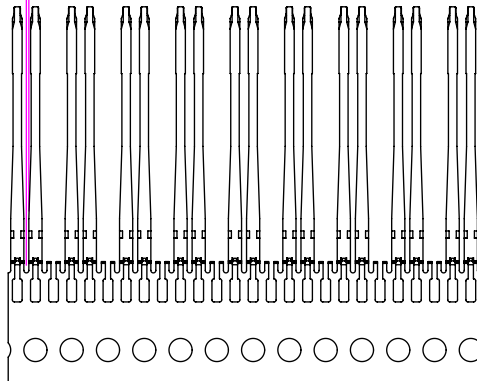

IN-PROCESS 3
CUT T-1M53-XX.X-X COMBS
(FOR QRM8-XXX-XX.X-D-DP-A-XX)

PROPRIETARY NOTE
THIS DOCUMENT CONTAINS CONFIDENTIAL AND PROPRIETARY INFORMATION AND ALL DESIGN, MANUFACTURING, REPRODUCTION, USE, PATENT RIGHTS AND SALES RIGHTS ARE EXPRESSLY RESERVED BY SAMTEC, INC. THIS DOCUMENT SHALL NOT BE DISCLOSED, IN WHOLE OR PART, TO ANY UNAUTHORIZED PERSON OR ENTITY NOR REPRODUCED, TRANSFERRED OR INCORPORATED IN ANY OTHER PROJECT IN ANY MANNER WITHOUT THE EXPRESS WRITTEN CONSENT OF SAMTEC, INC.

DO NOT SCALE DRAWING

SHEET SCALE: 3:1



520 PARK EAST BLVD, NEW ALBANY, IN 47150
PHONE: 812-944-6733 FAX: 812-948-5047
e-Mail info@SAMTEC.com code 55322

DESCRIPTION: .8MM Q-RATE TERMINAL ASSEMBLY

DWG. NO. QRM8-XXX-XX.X-X-D-XX-A-XX

BY: CLAY W 8/27/2008 SHEET 4 OF 4