

TMR134x

MicroAmpere High Frequency Response Omnipolar Magnetic Switch Sensor

Description

TMR134x is an omnipolar magnetic switch integrated the tunnel magnetoresistance (TMR) magnetic sensor and open-drain circuitry, which is able to detect the change of magnetic field and output high and low voltage signals for high accuracy position detection.

Unlike Hall/AMR sensors, TMR sensors with extremely high resistance values allows TMR134x to achieve the supply current as low as 1.5 μA while operating in the full-time power supply mode, and maintaining the response frequency of the magnetic signal is 1 kHz. Therefore, TMR134x can provide true continuous detection of magnetic field signals, avoiding sampling errors from the traditional time-sharing power supply mode.

TMR134x allows a wide range of operating supply voltages from 1.8 V to 5.5 V with excellent temperature characteristics, and can meet the requirements of most applications.

TMR134x is available in two compact SOT23-3 and LGA3L (2 mm \times 1.5 mm \times 0.63 mm) packages.

Features and benefits

- Tunneling magnetoresistance (TMR) technology
- Low power consumption: supply current 1.5 μA
- High frequency response: typ. 1 kHz
- Omnipolar operation
- Wide range supply voltages: 1.8 V to 5.5 V
- Open-drain push-pull output
- High sensitivity
- Excellent temperature stability
- High tolerance to external magnetic field interference
- RoHS & REACH compliant

Applications

- Utility meters: water, gas, and heat meters
- Proximity switches
- Speed sensing
- Linear and rotation position sensing

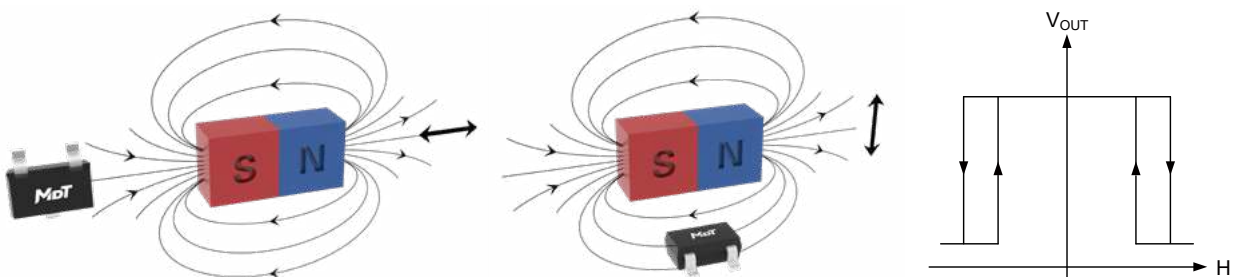

Selection Guide

Part Number	Supply Current	Response Frequency	Operating Ambient Temperature	Operating Point	Release Point	Package	Packing Form
TMR1340BS	1.5 μ A	1 kHz	-40°C to 125°C	\pm 14 Gs	\pm 10 Gs	SOT23-3	Tape & Reel
TMR1341G	1.5 μ A	1 kHz	-40°C to 125°C	\pm 34 Gs	\pm 30 Gs	LGA3L	Tape & Reel
TMR1342G	1.5 μ A	1 kHz	-40°C to 125°C	\pm 42 Gs	\pm 37 Gs	LGA3L	Tape & Reel
TMR1343G	1.5 μ A	1 kHz	-40°C to 125°C	\pm 50 Gs	\pm 45 Gs	LGA3L	Tape & Reel
TMR1345G	1.5 μ A	1 kHz	-40°C to 150°C	\pm 72 Gs	\pm 63 Gs	LGA3L	Tape & Reel

Note: Please contact MultiDimension Technology local sales for customizing operating and release points.

Catalogue

1. Functional Block Diagram.....	03
2. Switching Characteristics	03
3. Pin Configuration	03
4. Absolute Maximum Ratings	04
5. Electrical Specifications.....	04
6. Magnetic Specifications.....	05
7. Typical Supply Voltage Characteristics.....	06
8. Typical Temperature Characteristics	08
9. Application Information	10
10. Dimensions.....	11

1. Functional Block Diagram

TMR134x series switch chips are composed of TMR sensors and signal processing circuits. The TMR sensor detects external magnetic field, generates an analog voltage signal, and outputs a logical switch level after processing by the circuits as shown in Figure 1.

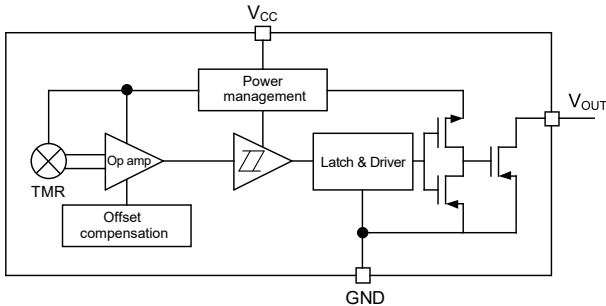

Figure 1. Block diagram

2. Switching Characteristics

The Figure 2 shows the sensing direction is parallel to the silkscreen surface of the package as shown by the arrow.

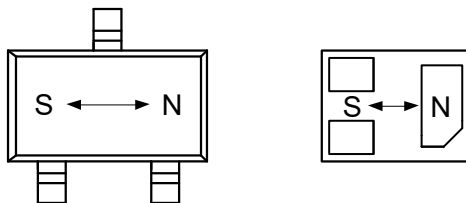

Figure 2. Sensing direction

The output is “High”, when power is on at zero magnetic field. B is the external magnetic field along the sensing direction, B_{OPS} (B_{OPN}) is the operating point, B_{RPS} (B_{RPN}) is the release point, and hysteresis B_H is define as the difference between B_{OPS} and B_{RPS} (B_{OPN} and B_{RPN}).

The sensor outputs a low level, when the magnetic field along the sensing axis exceeds the operate point B_{OPS} (B_{OPN}), and the device outputs a high level, when the magnetic field is reduced below the release point B_{RPS} (B_{RPN}) as shown in Figure 3.

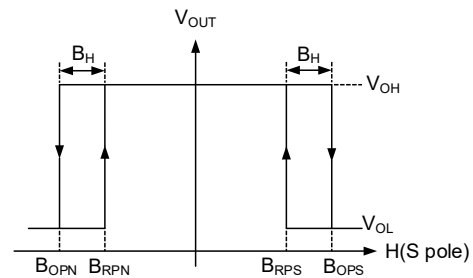

Figure 3. Switching characteristics

3. Pin Configuration

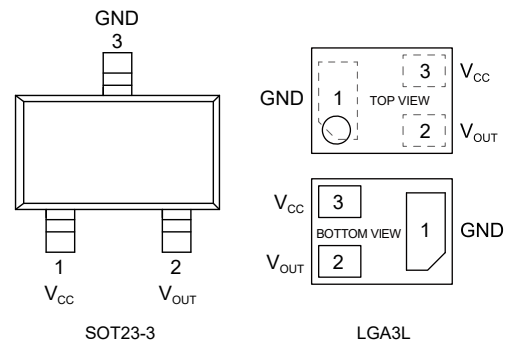

Figure 4. Pin configuration

Pin Number		Name	Function
SOT23-3	LGA3L		
1	3	V_{CC}	Power supply
2	2	V_{OUT}	Output
3	1	GND	Ground

4. Absolute Maximum Ratings

Parameters	Symbol	Min.	Max.	Unit
Supply voltage	V_{CC}	-0.3	7	V
Output current	I_{SINK}	-	20	mA
Magnetic flux density	B	-	4000	Gs
ESD performance (HBM)	V_{ESD}	-	4	kV
Operating ambient temperature	T_A	-40	125	°C
Storage ambient temperature	T_{STG}	-50	150	°C

Note: I_{SINK} is the current flowing through the pin of sensor, when the output is turned on.

5. Electrical Specifications

$V_{CC} = 3\text{ V}$, $T_A = 25\text{ °C}$

Parameter	Symbol	Condition	Min.	Typ.	Max.	Unit
Supply voltage	V_{CC}	operating	1.8	3.0	5.5	V
Output stress voltage	V_{stress}	-	-	-	5.5	V
Output leak current	I_{leak}	OUT = H	-	-	1	μA
On resistance of output	R_{ON}	OUT = L	-	-	10	Ω
Off resistance of output	R_{OFF}	OUT = H	-	10	-	M Ω
Output low voltage	V_{OL}	OP status	0	-	0.1	V
Supply current	I_{CC}	output open	-	1.5	-	μA
Response frequency	F	-	0 to 1000			Hz

Note: A 0.1 μF capacitor is connected between V_{CC} and GND, and 1 k Ω pull-up resistor is connected between V_{CC} and V_{OUT}

6. Magnetic Specifications

$V_{CC} = 3\text{ V}$, $T_A = 25\text{ }^\circ\text{C}$, a $0.1\text{ }\mu\text{F}$ capacitor is connected between V_{CC} and GND

TMR1340BS

Parameter	Symbol	Min.	Typ.	Max.	Unit
Operate point	B_{OPS}	10	14	25	Gs
	B_{OPN}	-25	-14	-10	Gs
Release point	B_{RPS}	5	10	20	Gs
	B_{RPN}	-20	-10	-5	Gs
Hysteresis	B_H	2	4	13	Gs

TMR1341G

Parameter	Symbol	Min.	Typ.	Max.	Unit
Operate point	B_{OPS}	25	34	37	Gs
	B_{OPN}	-37	-34	-25	Gs
Release point	B_{RPS}	-	30	-	Gs
	B_{RPN}	-	-30	-	Gs
Hysteresis	B_H	-	4	-	Gs

TMR1342G

Parameter	Symbol	Min.	Typ.	Max.	Unit
Operate point	B_{OPS}	-	42	-	Gs
	B_{OPN}	-	-42	-	Gs
Release point	B_{RPS}	-	37	-	Gs
	B_{RPN}	-	-37	-	Gs
Hysteresis	B_H	-	5	-	Gs

TMR1343G

Parameter	Symbol	Min.	Typ.	Max.	Unit
Operate point	B_{OPS}	-	50	-	Gs
	B_{OPN}	-	-50	-	Gs
Release point	B_{RPS}	-	45	-	Gs
	B_{RPN}	-	-45	-	Gs
Hysteresis	B_H	-	5	-	Gs

TMR1345G

Parameter	Symbol	Min.	Typ.	Max.	Unit
Operate point	B_{OPS}	-	72	-	Gs
	B_{OPN}	-	-72	-	Gs
Release point	B_{RPS}	-	63	-	Gs
	B_{RPN}	-	-63	-	Gs
Hysteresis	B_H	-	9	-	Gs

7. Typical Supply Voltage Characteristics

TMR1340BS Supply Voltage Characteristics

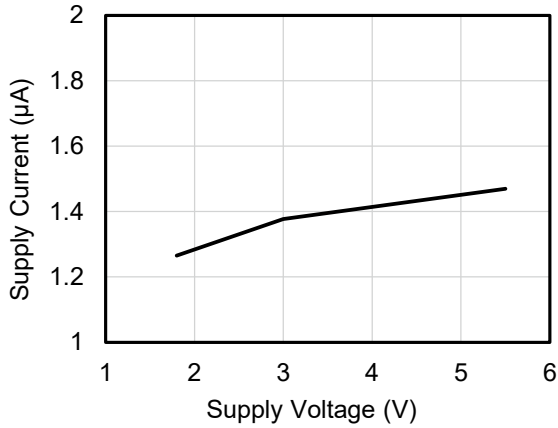

Figure 5. Supply current versus supply voltage (T_A=25°C)

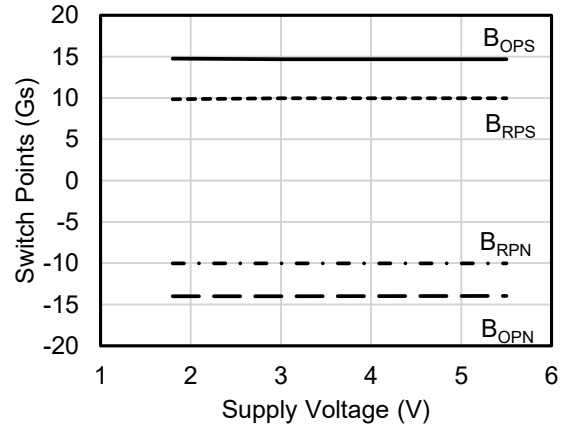

Figure 6. Switch points versus supply voltage (T_A=25°C)

TMR1341G, 1342G, 1343G, 1345G Supply Voltage Characteristics

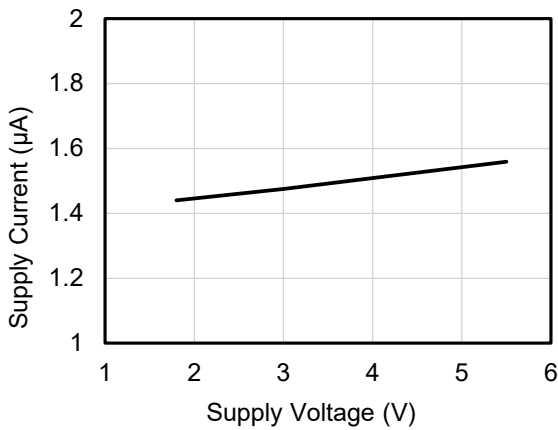

Figure 7. Supply current versus supply voltage (T_A=25°C)

TMR1341G Supply Voltage Characteristics

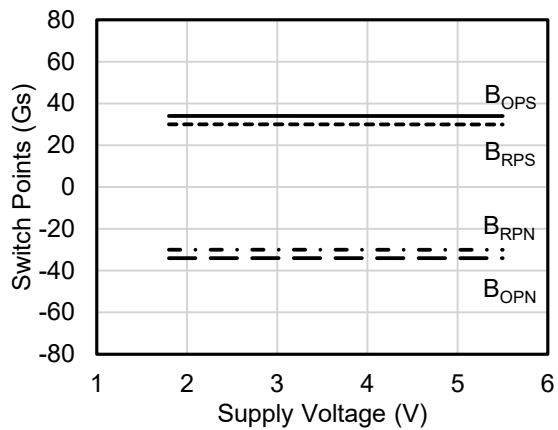

Figure 8. Switch points versus supply voltage (T_A=25°C)

TMR1342G Supply Voltage Characteristics

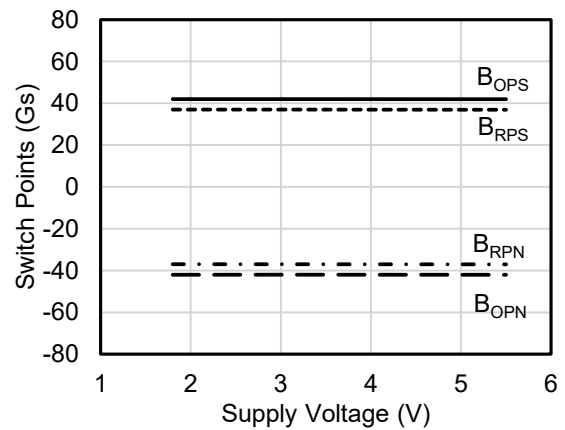

Figure 9. Switch points versus supply voltage (T_A=25°C)

TMR1343G Supply Voltage Characteristics

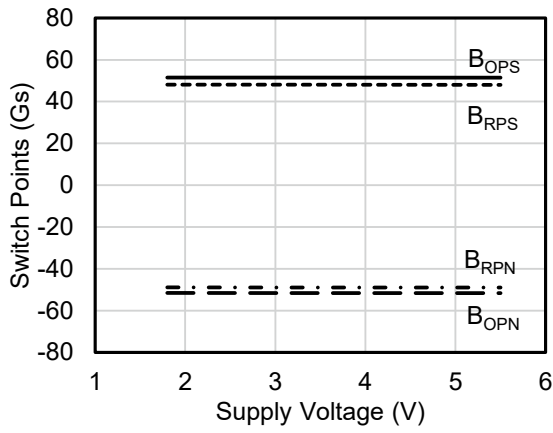

Figure 10. Switch points versus supply voltage ($T_A=25^\circ\text{C}$)

TMR1345G Supply Voltage Characteristics

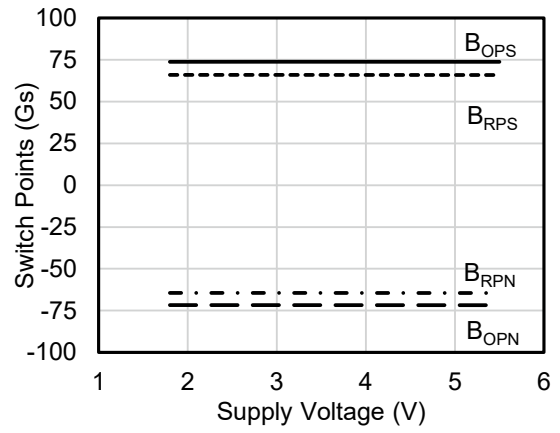

Figure 11. Switch points versus supply voltage ($T_A=25^\circ\text{C}$)

8. Typical Temperature Characteristics

TMR1340BS Temperature Characteristics

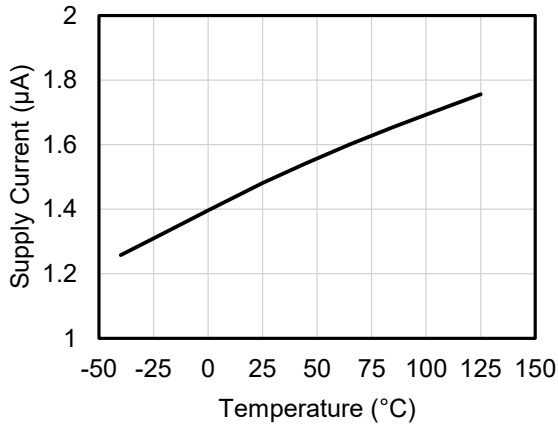

Figure 12. Supply current versus temperature ($V_{CC} = 3\text{ V}$)

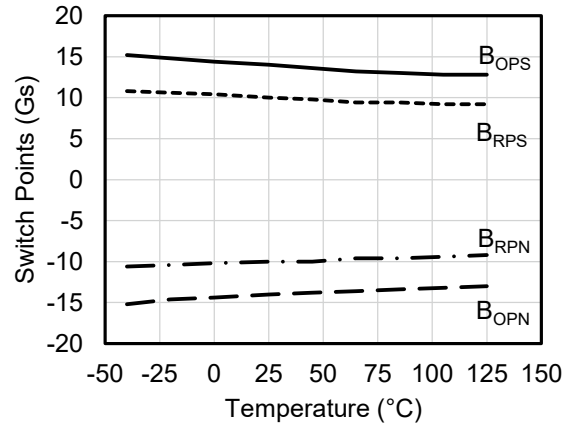

Figure 13. Switch points versus temperature ($V_{CC} = 3\text{ V}$)

TMR1341G, 1342G, 1343G, 1345G Temperature Characteristics

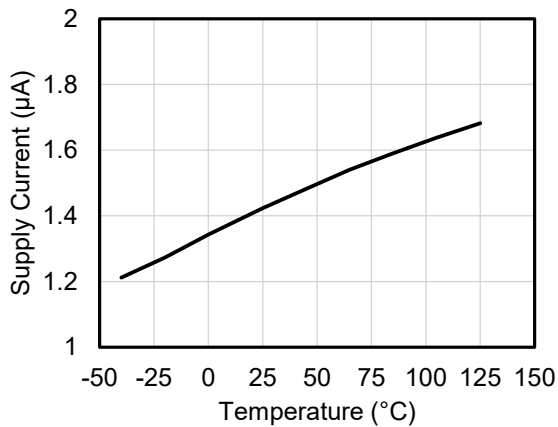

Figure 14. Supply current versus temperature ($V_{CC} = 3\text{ V}$)

TMR1341G Temperature Characteristics

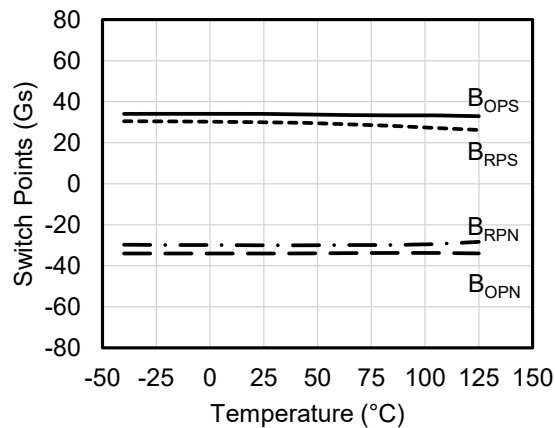

Figure 15. Switch points versus temperature ($V_{CC} = 3\text{ V}$)

TMR1342G Temperature Characteristics

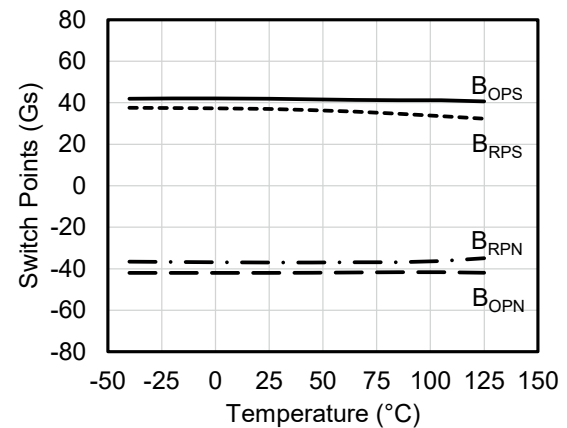

Figure 16. Switch points versus temperature ($V_{CC} = 3\text{ V}$)

TMR1343G Temperature Characteristics

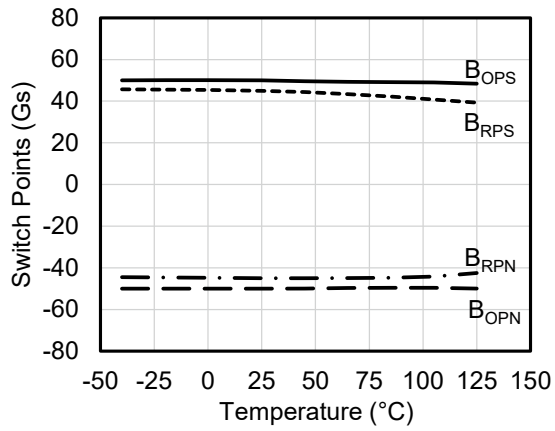

Figure 17. Switch points versus temperature ($V_{CC} = 3\text{ V}$)

TMR1345G Temperature Characteristics

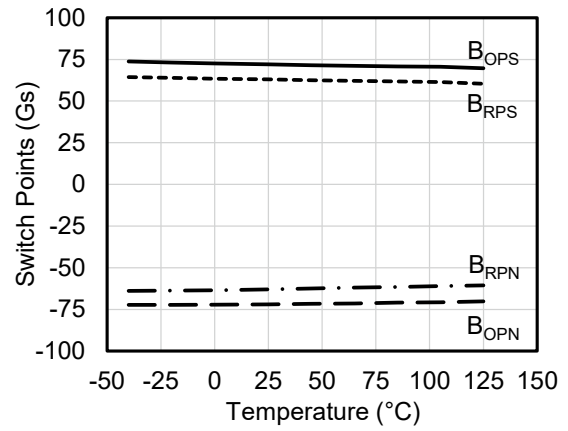

Figure 18. Switch points versus temperature ($V_{CC} = 3\text{ V}$)

9. Application Information

It is recommended to add a filter capacitor between the sensor power supply and ground (close to the sensor) to reduce external noise. As shown in Figure 19, the typical value is 0.1 μF .

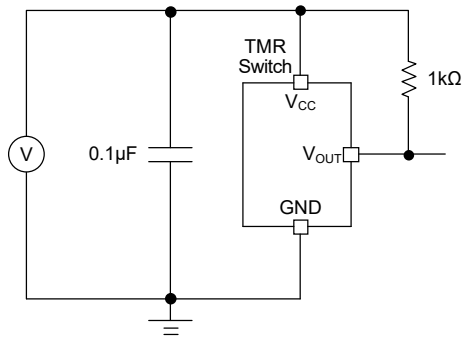

Figure 19. Application circuit diagram

The TMR134x series sensor chips are not suitable for driving power loads. The general method of use is utilizing the output voltage of V_{OUT} pin as a signal to input the MCU or drive a triode or MOS as shown in Figure 20.

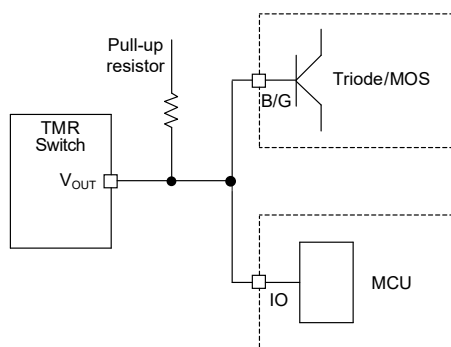

Figure 20. Application diagram for driving power load

Common failure conditions:

- The supply voltage exceeds the limit of absolute maximum ratings
- Absence of matching filter capacitor to power supply when the power supply is unstable, which can cause the product to restart repeatedly
- Using switch output V_{OUT} to control high-power relays, etc., and cause I_{SINK} exceeding the limit of absolute maximum ratings
- The external magnetic field exceeds the limit of absolute maximum ratings
- Operating in a humid environment for a long time, causing vapor penetration and increased power consumption
- Overheating when soldering
- Over bending of pins

10. Dimensions

SOT23-3 Package

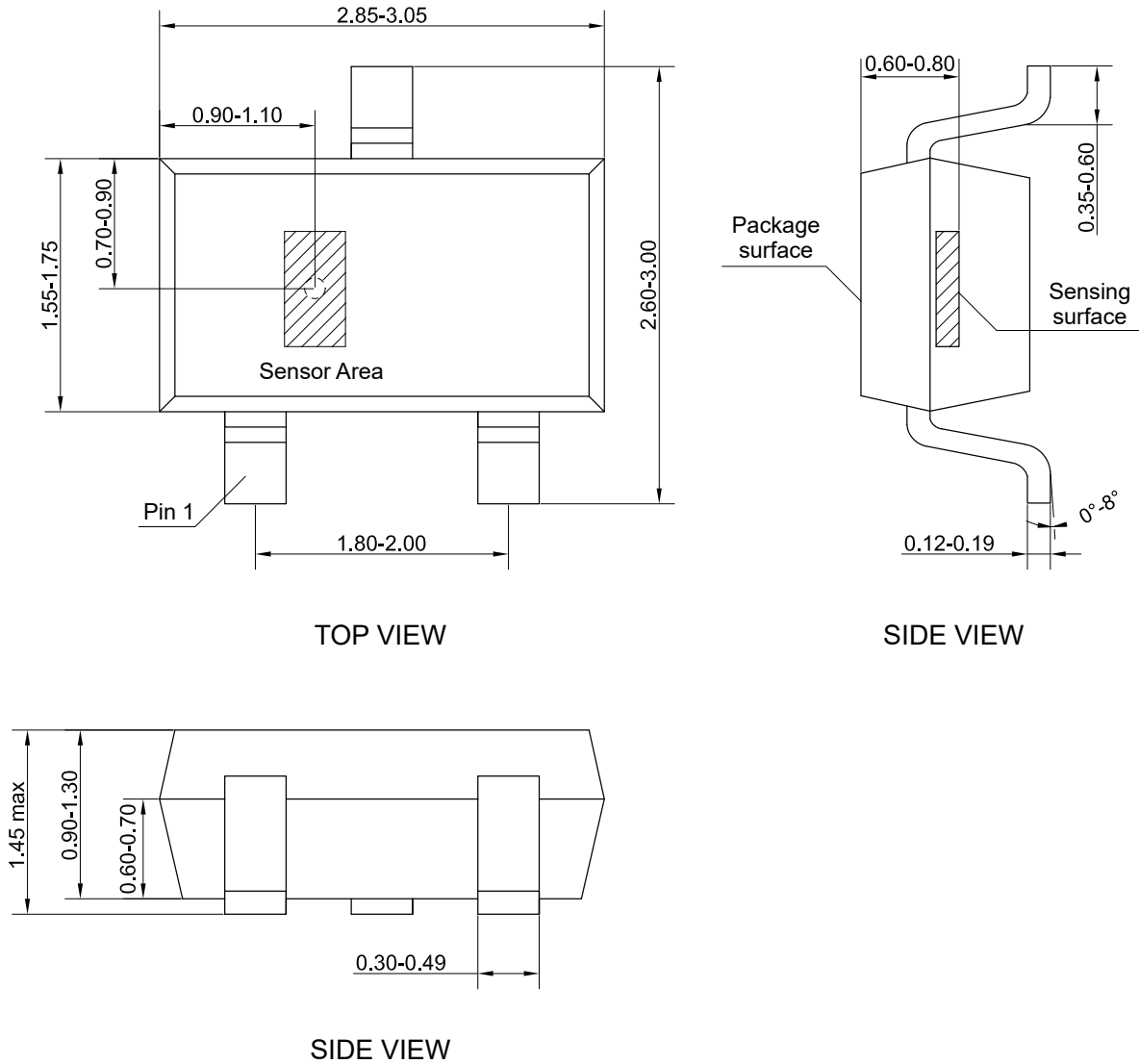

Figure 21. Package outline of SOT23-3 (unit: mm)

LGA3L Package

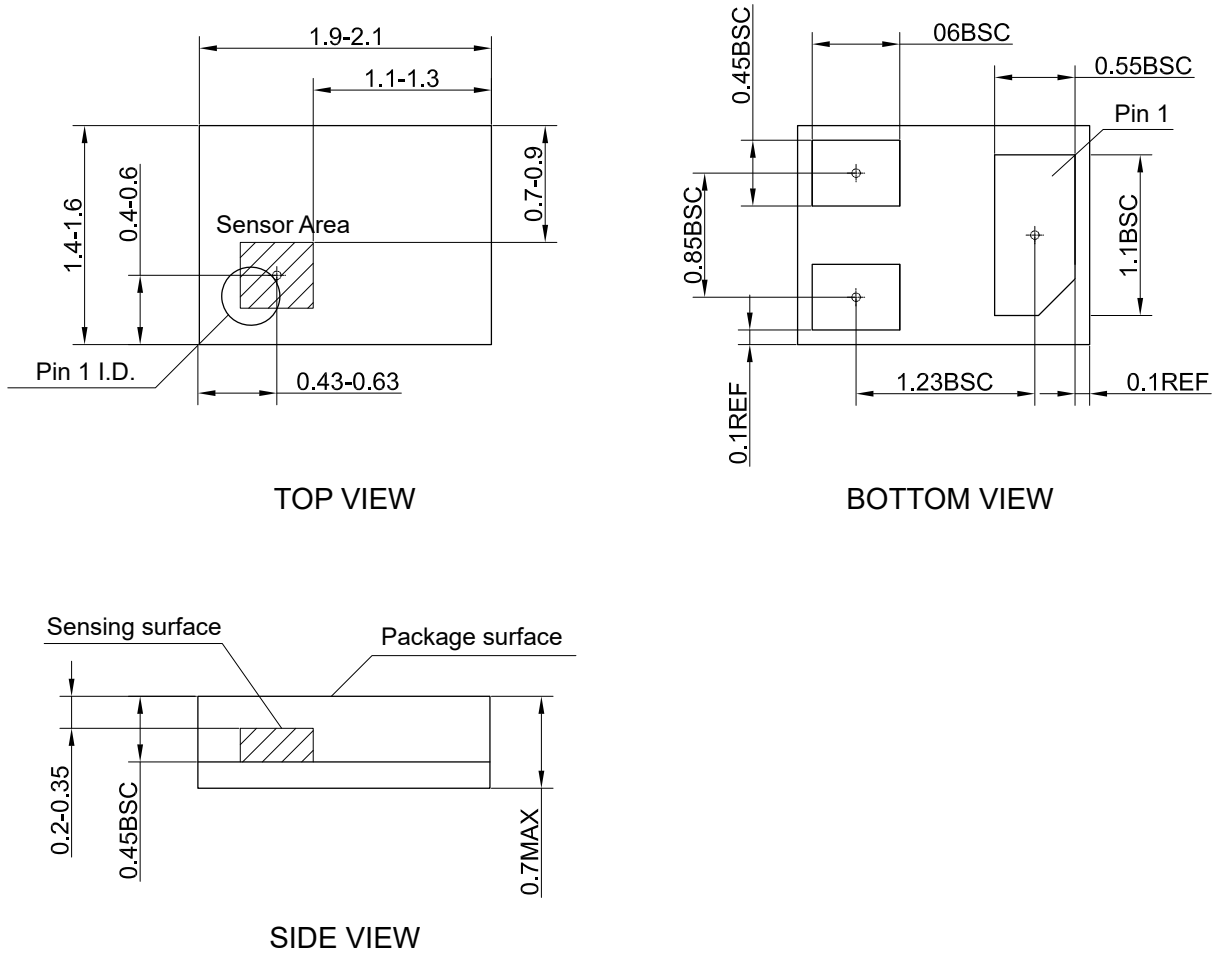

Figure 22. Package outline of LGA3L (unit: mm)

Copyright © 2021 by MultiDimension Technology Co., Ltd.

Information furnished herein by MultiDimension Technology Co., Ltd. (hereinafter MDT) is believed to be accurate and reliable. However, MDT disclaims any and all warranties and liabilities of any kind, with respect to any examples, hints or any performance or use of technical data as described herein and/or any information regarding the application of the product, including without limitation warranties of non-infringement of intellectual property rights of any third party. This document neither conveys nor implies any license under patent or other industrial or intellectual property rights. Customer or any third-party must further determine the suitability of the MDT products for its applications to avoid the applications default of customer or third-party. MDT accept no liability in this respect.

MDT does not assume any liabilities of any indirect, incidental, punitive, special or consequential damages (including without limitation of lost profits, lost savings, business interruption, costs related to the removal or replacement of any products or rework charges) whether or not such damages are based on tort (including negligence), warranty, breach of contract or any other legal theory. Notwithstanding any damages that customer might incur for any reason whatsoever, MDT's aggregate and cumulative liability towards customer for the products described herein shall be limited in accordance with the terms and conditions of commercial sale of MDT.

Absolute maximum ratings are the extreme limits the device will withstand without damage to the MDT product. However, the electrical and mechanical characteristics are not guaranteed as the maximum limits (above recommended operating conditions) are approached. MDT disclaims any and all warranties and liabilities of the MDT product will operate at absolute maximum ratings.

Specifications may change without notice.

Please download latest document from our official website www.dowaytech.com/en.

Recycling

The product(s) in this document need to be handed over to a qualified solid waste management services company for recycling in accordance with relevant regulations on waste classification after the end of the product(s) life.



No.2 Guangdong Road, Zhangjiagang Free Trade Zone, Jiangsu, China

Web: www.dowaytech.com/en E-mail: info@dowaytech.com

