

REVISIONS				
REV	ECO	DESCRIPTION	DATE	BY APPR
A1	-	RELEASED DRAWING	Jul-16-18	Flan Tommy

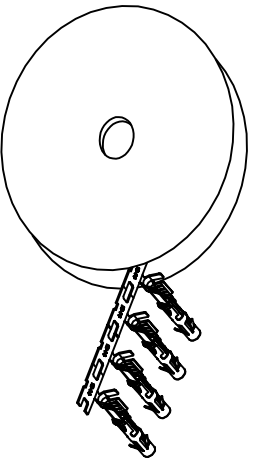

CONTACT ORIENTATION ON ROLL(3000PCS/COIL)

NOTES : (UNLESS OTHERWISE SPECIFIED)

1. MATERIAL :
  - 1.1. CONTACT BODY : COPPER ALLOY.
  - 1.2. OUTER SPRING : STAINLESS STEEL.
2. SPECIFICATIONS :
  - 2.1 CURRENT RATING : 13A MAX.
  - 2.2 TERMINATION TYPE : CRIMPING.
  - 2.3 WIRE RANGE : 14~16AWG.
  - 2.4 WIRE INSULATION DIA(MAX) :  $\phi$ 3.2mm.
3. RoHS COMPLIANT.
4. ALL DIMENSIONS ARE FOR REFERENCE USE ONLY.
5. AVAILABLE TOOLS :
  - 5.1 HAND CRIMPER : MFX-3954.
  - 5.2 CRIMP APPLICATOR : MFX-3957.
  - 5.3 EXTRACTION TOOL : QXRT16.

P/N	CONTACT PLATING(MATING AREA)
SS14M2T	TIN PLATING OVER NICKEL.
SS14M2N	NICKEL PLATING OVER COPPERIZE.
SS14M2F	GOLD FLASH PLATING OVER NICKEL.
SS14M2G5	5 $\mu$ "GOLD PLATING OVER NICKEL.
SS14M2G10	10 $\mu$ "GOLD PLATING OVER NICKEL.
SS14M2G15	15 $\mu$ "GOLD PLATING OVER NICKEL.
SS14M2G30	30 $\mu$ "GOLD PLATING OVER NICKEL.

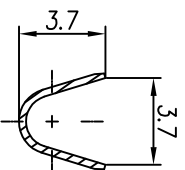

SECTION A-A

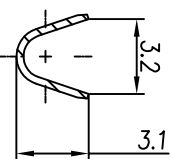

SECTION B-B

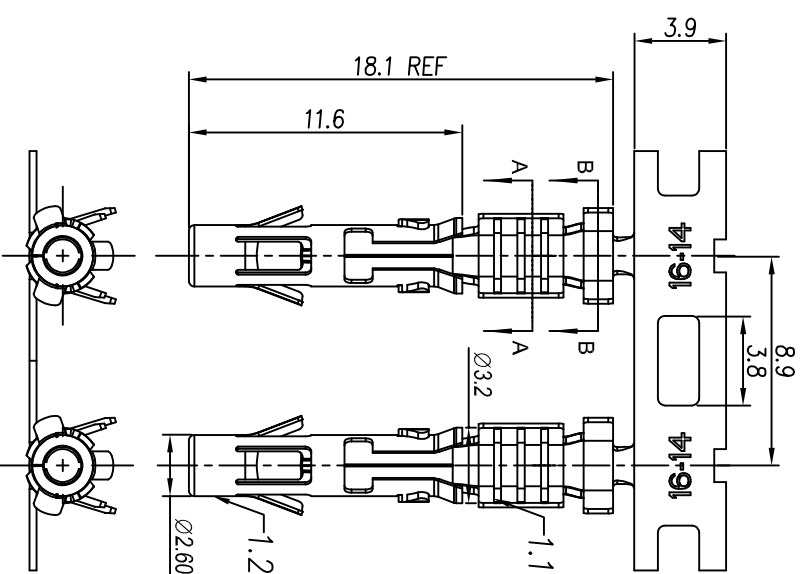

QUANTITY	PART NUMBER	DESCRIPTION	ITEM

MATERIALS LIST

UNLESS OTHERWISE SPECIFIED	SIGNATURES	DATE
1) All dimensions are in millimeters. 2) Tolerances are as follows: 1 PL, DEC & 0.30 Fractions, ±1/4 3 PL, DEC & 0.08 Angles, ±1'	Flan	Jul-16-18
3) Note reference = $\Delta$	Tommy	Jul-16-18

PROCESS SPECIFICATIONS	CUSTOMER	SIZE	TYPE	SCALE	SHEET	OF
MATERIAL SPECIFICATIONS: THE DRAWINGS IS SUPERSEDES ALL PREVIOUS DRAWINGS. SPECIFICATIONS AND PERFORMANCE DATA OF THE MATERIAL CORPORATION. NO RIGHTS OF REPRODUCTION ARE GRANTED. ALL MANUFACTURING VARIATIONS.	ECO-MATE SOCKET CONTACT, STAMPED, 14-16AWG, SIZE 16	B	C-	NONE	1	1

**Amphenol**

Sine Systems - www.amphenol-sine.com  
44724 Morley Drive  
Clinton Township, MI 48036

ECO-MATE SOCKET CONTACT, STAMPED, 14-16AWG, SIZE 16

SS14M2XX A1