

International
IR Rectifier

Plug N Drive™ Integrated Power
 Module for Energy Efficient Motor Drives

IRAM136-0461G
iMOTION™ Series
4A, 600V

Description

International Rectifier's IRAM136-0461G is an Integrated Power Module developed and optimized for electronic motor control in energy saving applications. Targeting the sub 300W three-phase motor drive applications, such as fan or refrigerator compressor drives, this module offers the highest level of integration available in the market today. It features an input diode rectification bridge and a three-phase inverter, complete with bootstrap diodes, high voltage gate driver IC, current shunt resistor and temperature sensor. This high performance AC motor-driver is housed in a compact single-in-line isolated package for a very simple design.

The internal shunt offers easy current feedback for precise control and safe operation. A built-in temperature monitor and logic level shut-down function, along with the short-circuit rated IGBTs and integrated under-voltage lockout function, deliver high level of protection and fail-safe operation.

Features

- Internal Rectifier Diode Bridge
- Internal Shunt Resistor
- Integrated Gate Drivers and Bootstrap Diodes
- Temperature Monitor
- Undervoltage lockout for all channels
- Matched propagation delay for all channels
- Schmitt-triggered input logic
- Cross-conduction prevention logic
- Lower di/dt gate driver for better noise immunity
- Motor Power range 0.1~0.3kW / up to 253V, 50/60Hz
- Isolation 2000V_{RMS}/1min

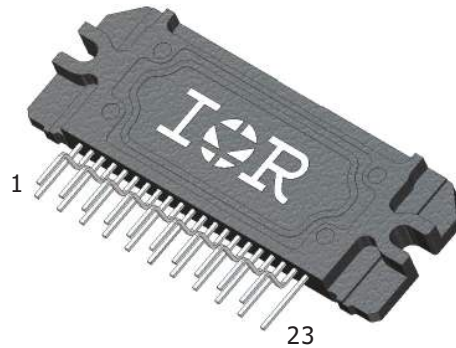

Absolute Maximum Ratings

Parameter	Description	Max. Value	Units
V _{RRM}	Input Bridge Blocking Voltage	600	V
V _{CES}	IGBT Blocking Voltage	600	
V ⁺	Positive Bus Input Voltage	450	
I _O @ T _C =25°C	RMS Phase Current (F _{PWM} =20kHz)	3.6	
I _O @ T _C =100°C	RMS Phase Current (F _{PWM} =20kHz)	2	
I _{O PK}	Pulsed RMS Phase Current (t _p <100ms, F _{PWM} =20kHz)	5	kHz
F _{PWM}	PWM Carrier Frequency	20	
P _d	Power dissipation per IGBT @ T _C =25°C	16	W
V _{ISO}	Isolation Voltage (1min)	2000	V _{RMS}
T _J (IGBT & Diodes)	Operating Junction temperature Range	-40 to +150	°C
T _J (Driver IC)	Operating Junction temperature Range	-40 to +150	
T	Mounting torque (M3 screw)	1.0	Nm

Internal Electrical Schematic - IRAM136-0461G

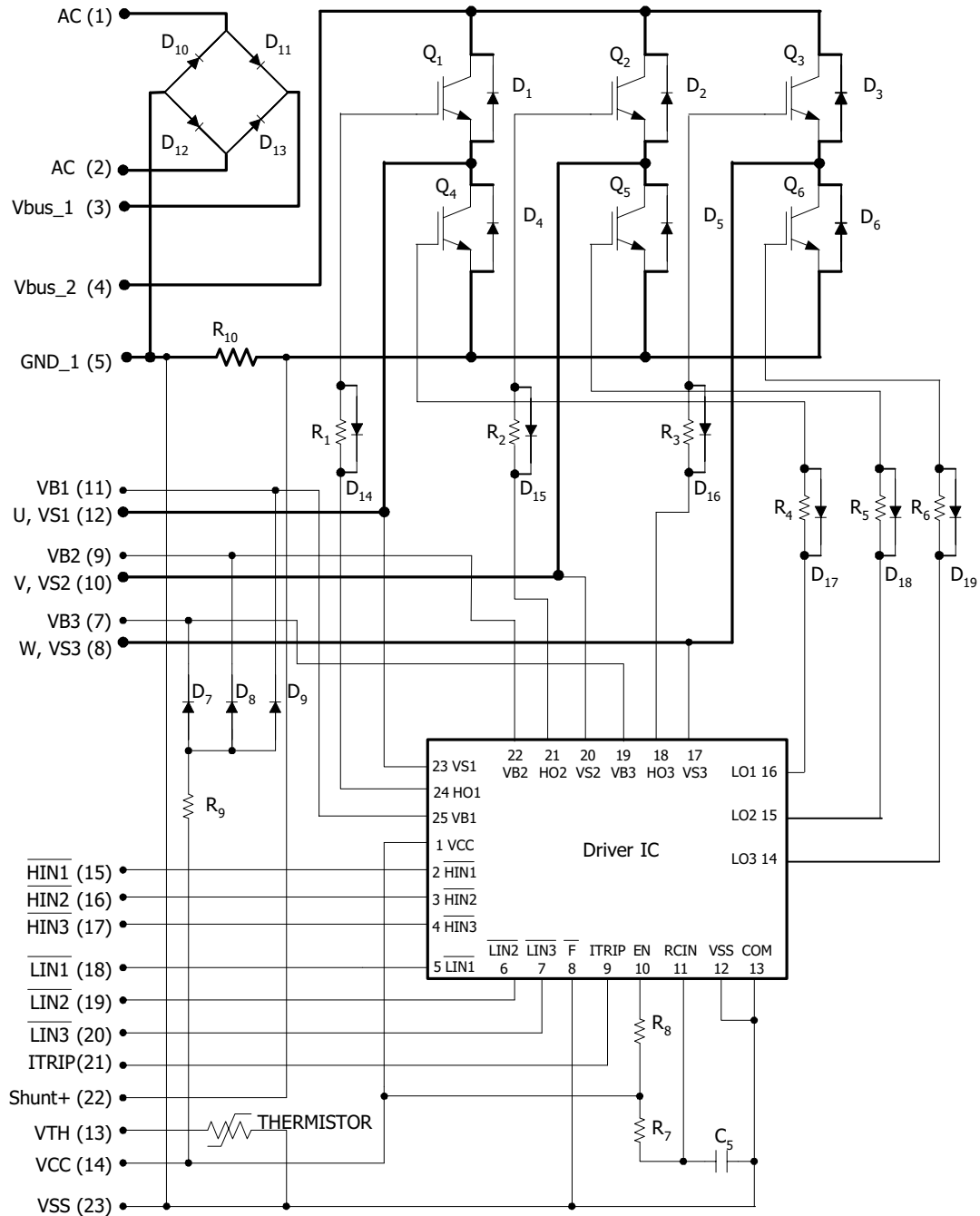

Absolute Maximum Ratings (Continued)

Symbol	Parameter	Max	Units	
I_{DC}	Input Bridge DC Output Current	9.4	A	@ $T_C=100^\circ\text{C}$, 180° cond. square wave
$I_{F(AV)}$	Average Output Forward Current	8.7	A	@ $T_C=100^\circ\text{C}$, 180° cond. sine wave
I_{FSM}	Peak One Cycle Non-Repetitive Surge Current @ $T_J = 150^\circ\text{C}$	100	A	8.3ms Sine Pulse rated V_{RRM} applied
		95	A	10ms Sine Pulse 80% rated V_{RRM} applied
I^2t	I^2t for fusing	45.12	A^2s	10ms Sine Pulse 80% rated V_{RRM} applied
$I^2t^{0.5}$	$I^2t^{0.5}$ for fusing	638	$\text{A}^2\text{s}^{0.5}$	$t=0.1$ to 10 ms, no Voltage applied

Absolute Maximum Ratings Driver Function

Absolute Maximum Ratings indicate substained limits beyond which damage to the device may occur. All voltage parameters are absolute voltages referenced to COM/ V_{SS} .

Symbol	Parameter	Min	Max	Units	Conditions
I_{BDF}	Bootstrap Diode Peak Forward Current	---	4.5	A	$t_p=10\text{ms}$, $T_J = 150^\circ\text{C}$, $T_C=100^\circ\text{C}$
$P_{BR \text{ Peak}}$	Bootstrap Resistor Peak Power (Single Pulse)	---	25.0	W	$t_p=100\mu\text{s}$, $T_C = 100^\circ\text{C}$
$V_{S1,2,3}$	High Side floating supply voltage	$V_{B1,2,3} - 25$	$V_{B1,2,3} + 0.3$	V	
$V_{B1,2,3}$	High Side floating supply voltage	-0.3	600	V	
V_{CC}	Low Side and logic fixed supply voltage	-0.3	20	V	
V_{IN}	Input voltage LIN, HIN, I_{Trip}	-0.3	Lower of ($V_{SS}+15\text{V}$) or $V_{CC}+0.3\text{V}$	V	

Input Bridge Section Electrical Characteristics @T_J= 25°C

Symbol	Parameter	Min	Typ	Max	Units	Conditions
V _{FM}	Forward Voltage Drop	---	1	1.2	V	@ I _{FM} = 4A, T _J =25°C
		---	0.9	1.05	V	@ I _{FM} = 4A, T _J =150°C
r _t	Forward Slope resistance	---	22	59	mΩ	T _J =150°C
V _{F(TD)}	Threshold Voltage	---	0.81	0.84	V	
I _{RM}	Reverse Leakage Current	---	2	15	μA	T _J =25°C, V _R = rated V _{RR}
		---	115	190		T _J =150°C, V _R = rated V _{RR}

Inverter Section Electrical Characteristics @T_J= 25°C

Symbol	Parameter	Min	Typ	Max	Units	Conditions
V _{(BR)CES}	Collector-to-Emitter Breakdown Voltage	600	---	---	V	V _{IN} =5V, I _C =250μA
ΔV _{(BR)CES} / ΔT	Temperature Coeff. Of Breakdown Voltage	---	0.74	---	V/°C	V _{IN} =5V, I _C =1.0mA (25°C - 150°C)
V _{CE(ON)}	Collector-to-Emitter Saturation Voltage	---	1.95	2.20	V	I _C =2A, V _{CC} =15V
		---	2.40	2.80		I _C =2A, V _{CC} =15V, T _J =150°C
I _{CES}	Zero Gate Voltage Collector Current	---	1	75	μA	V _{IN} =5V, V ⁺ =600V
		---	160	---		V _{IN} =5V, V ⁺ =600V, T _J =150°C
V _{FM}	Diode Forward Voltage Drop	---	1.25	1.65	V	I _C =2A
		---	1.20	1.60		I _C =2A, T _J =150°C
V _{BDFM}	Bootstrap Diode Forward Voltage Drop	--	--	1.25	V	I _F =1A
		---	---	1.10		I _F =1A, T _J =125°C
R _{BR}	Bootstrap Resistor Value	---	22	---	Ω	
ΔR _{BR} /R _{BR}	Bootstrap Resistor Tolerance	---	---	±5	%	

Inverter Section Switching Characteristics @ $T_J = 25^\circ\text{C}$

Symbol	Parameter	Min	Typ	Max	Units	Conditions
E_{ON}	Turn-On Switching Loss	---	180	260	μJ	$I_C=2\text{A}$, $V^+=400\text{V}$ $V_{CC}=15\text{V}$, $L=1\text{mH}$ Energy losses include "tail" and diode reverse recovery See CT1
E_{OFF}	Turn-Off Switching Loss	---	65	140		
E_{TOT}	Total Switching Loss	---	245	400		
E_{REC}	Diode Reverse Recovery energy	---	5	15		
t_{RR}	Diode Reverse Recovery time	---	240	---	ns	See CT1
E_{ON}	Turn-on Switching Loss	---	210	305	μJ	$I_C=2\text{A}$, $V^+=400\text{V}$ $V_{CC}=15\text{V}$, $L=1\text{mH}$, $T_J=150^\circ\text{C}$ Energy losses include "tail" and diode reverse recovery See CT1
E_{OFF}	Turn-off Switching Loss	---	80	150		
E_{TOT}	Total Switching Loss	---	290	455		
E_{REC}	Diode Reverse Recovery energy	---	15	35		
t_{RR}	Diode Reverse Recovery time	---	285	---	ns	See CT1
Q_G	Turn-On IGBT Gate Charge	---	0.84	1.3	nC	$I_C=2\text{A}$, $V^+=400\text{V}$, $V_{GE}=15\text{V}$
RBSOA	Reverse Bias Safe Operating Area	FULL SQUARE				$T_J=150^\circ\text{C}$, $I_C=2\text{A}$, $V_P=600\text{V}$ $V^+=450\text{V}$ $V_{CC}=+15\text{V}$ to 0V See CT3
SCSOA	Short Circuit Safe Operating Area	10	---	---	μs	$T_J=150^\circ\text{C}$, $V_P=600\text{V}$, $V^+=360\text{V}$, $V_{CC}=+15\text{V}$ to 0V See CT2
I_{CSC}	Short Circuit Collector Current	---	11	---	A	$T_J=150^\circ\text{C}$, $V_P=600\text{V}$, $t_{SC}<10\mu\text{s}$ $V^+=360\text{V}$, $V_{GE}=15\text{V}$ $V_{CC}=+15\text{V}$ to 0V See CT2

Recommended Operating Conditions

The Input/Output logic timing diagram is shown in Figure 1. For proper operation the device should be used within the recommended conditions. All voltages are absolute referenced to COM/ V_{SS} . The offset is tested with all supplies biased at 15V differential (Note 2)

Symbol	Definition	Min	Max	Units
AC	AC input voltage	---	253	V
AC	AC input frequency	50	60	Hz
$V_{B1,2,3}$	High side floating supply voltage	V_S+12	V_S+20	V
$V_{S1,2,3}$	High side floating supply offset voltage	Note 3	450	
V_{CC}	Low side and logic fixed supply voltage	12	20	V
V_{ITRIP}	I_{TRIP} input voltage	V_{SS}	$V_{SS}+5$	
V_{IN}	Logic input voltage LIN, HIN	V_{SS}	$V_{SS}+5$	V

Note 2: For more details, see IR21365 data sheet

Note 3: Logic operational for V_S from GND -5V to GND +600V. Logic state held for V_S from GND -5V to GND - V_{BS} . (please refer to DT97-3 for more details)

Static Electrical Characteristics Driver Function

V_{BIAS} (V_{CC} , $V_{BS1,2,3}$)=15V, unless otherwise specified. The V_{IN} and I_{IN} parameters are referenced to V_{SS}/COM and are applicable to all six channels. (Note 2)

Symbol	Definition	Min	Typ	Max	Units
V_{IH}	Logic "0" input voltage	3.0	---	---	V
V_{IL}	Logic "1" input voltage	---	---	0.8	V
V_{CCUV+} V_{BSUV+}	V_{CC} and V_{BS} supply undervoltage Positive going threshold	10.6	11.1	11.6	V
V_{CCUV-} V_{BSUV-}	V_{CC} and V_{BS} supply undervoltage Negative going threshold	10.4	10.9	11.4	V
V_{CCUVH} V_{BSUVH}	V_{CC} and V_{BS} supply undervoltage lock-out hysteresis	---	0.2	---	V
$V_{IN,Clamp}$	Input Clamp Voltage (HIN, LIN, T/ I_{TRIP}) $I_{IN}=10\mu A$	4.9	5.2	5.5	V
I_{QBS}	Quiescent V_{BS} supply current $V_{IN}=0V$	---	---	165	μA
I_{QCC}	Quiescent V_{CC} supply current $V_{IN}=0V$	---	---	3.35	mA
I_{LK}	Offset Supply Leakage Current	---	---	60	μA
I_{IN+} , I_{EN+}	Input bias current $V_{IN}=5V$	---	200	300	μA
I_{IN-} , I_{EN-}	Input bias current $V_{IN}=0V$	---	100	220	μA
I_{TRIP+}	I_{TRIP} bias current $V_{ITRIP}=5V$	---	30	100	μA
I_{TRIP-}	I_{TRIP} bias current $V_{ITRIP}=0V$	---	0	1	μA

Static Electrical Characteristics Driver Function (Continued)

Symbol	Definition	Min	Typ	Max	Units
$V(I_{TRIP})$	I_{TRIP} threshold Voltage	3.85	4.3	4.75	V
$V(I_{TRIP,HYS})$	I_{TRIP} Input Hysteresis	---	150	---	mV
$R_{ON,FLT}$	Falut Output ON Resistance	---	70	100	Ohm

Dynamic Electrical Characteristics

Driver only timing unless otherwise specified.

Symbol	Parameter	Min	Typ	Max	Units	Conditions
T_{ON}	Input to Output propagation turn-on delay time (see fig.11)	---	700	---	ns	$V_{CC}=V_{BS}= 15V, I_C=2A, V^+=400V$
T_{OFF}	Input to Output propagation turn-off delay time (see fig. 11)	---	515	---	ns	
T_{FLIN}	Input Filter time (HIN, LIN)	100	200	---	ns	$V_{IN}=0$ & $V_{IN}=5V$
$T_{BLT-Trip}$	I_{TRIP} Blanking Time	100	150	---	ns	$V_{IN}=0$ & $V_{IN}=5V$
D_T	Dead Time ($V_{BS}=V_{CC}=15V$)	220	290	360	ns	$V_{BS}=V_{CC}=15V$
M_T	Matching Propagation Delay Time (On & Off)	---	40	75	ns	$V_{CC}= V_{BS}= 15V$, external dead time > 400ns
T_{ITrip}	I_{Trip} to six switch to turn-off propagation delay (see fig. 2)	---	---	1.75	μs	$V_{CC}=V_{BS}= 15V, I_C=10A, V^+=300V$
$T_{FLT-CLR}$	Post I_{Trip} to six switch to turn-off clear time (see fig. 2)	---	7.7	---	ms	$T_C = 25^\circ C$
		---	6.7	---		$T_C = 100^\circ C$

Thermal and Mechanical Characteristics

Symbol	Parameter	Min	Typ	Max	Units	Conditions
$R_{th(J-C)}$ IGBT	Junction to case thermal resistance (IGBT).	---	6.6	7.6	°C/W	Flat, greased surface. Heatsink compound thermal conductivity 1W/mK
$R_{th(J-C)}$ FW Diode	Junction to case thermal resistance (FW Diode).	---	8.8	10.8		
$R_{th(J-C)}$ Input Diode	Junction to case thermal resistance (Input Diode).	---	6.0	7.5		
$R_{th(C-S)}$	Case to Sink thermal resistance	---	0.1	---		
T	Mounting Torque	0.5	0.6	1.0	Nm	Mounting Torque

Internal Current Sensing Resistor - Shunt Characteristics

Symbol	Parameter	Min	Typ	Max	Units	Conditions
R_{Shunt}	Resistance	336.6	340.0	343.4	mΩ	$T_C = 25^\circ\text{C}$
T_{Coeff}	Temperature Coefficient	0	---	200	ppm/°C	
P_{Shunt}	Power Dissipation	---	---	1.5	W	$-40^\circ\text{C} < T_C < 100^\circ\text{C}$
T_{Range}	Temperature Range	-40	---	125	°C	

Internal NTC - Thermistor Characteristics

Parameter	Definition	Min	Typ	Max	Units	Conditions
R_{25}	Resistance	20.9	22	23.1	kΩ	$T_C = 25^\circ\text{C}$
R_{125}	Resistance	2.25	2.52	2.5	kΩ	$T_C = 125^\circ\text{C}$
B	B-constant (25-50°C)	3832	3950	4335	k	$R_2 = R_1 e^{[B(1/T_2 - 1/T_1)]}$
Temperature Range		-40		125	°C	
Typ. Dissipation constant			1		mW/°C	$T_C = 25^\circ\text{C}$

Thermistor Pin Connection

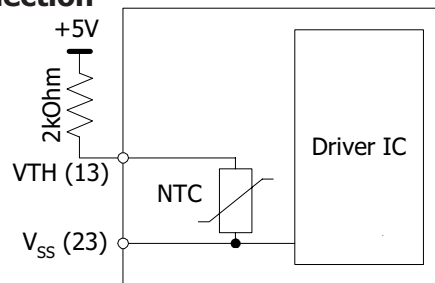

Module Pin-Out Description

Pin	Name	Description
1	AC	AC Input
2	AC	AC Input
3	Vbus_1	Input Bridge Positive Output
4	Vbus_2	Positive Bus Input Voltage
5	GND	Negative Bus Input Voltage
6	na	none
7	VB3	High Side Floating Supply voltage 3
8	W,VS3	Output 3 - High Side Floating Supply Offset Voltage 3
9	VB2	High Side Floating Supply voltage 2
10	V,VS2	Output 2 - High Side Floating Supply Offset Voltage 2
11	VB1	High Side Floating Supply voltage 1
12	U,VS1	Output 1 - High Side Floating Supply Offset Voltage 1
13	VTH	Temperature Feedback
14	VCC	+15V Main Supply
15	$\overline{\text{HIN1}}$	Logic Input High Side Gate Driver - Phase 1
16	$\overline{\text{HIN2}}$	Logic Input High Side Gate Driver - Phase 2
17	$\overline{\text{HIN3}}$	Logic Input High Side Gate Driver - Phase 3
18	$\overline{\text{LIN1}}$	Logic Input Low Side Gate Driver - Phase 1
19	$\overline{\text{LIN2}}$	Logic Input Low Side Gate Driver - Phase 2
20	$\overline{\text{LIN3}}$	Logic Input Low Side Gate Driver - Phase 3
21	I_{TRIP}	Current Sense and Itrip Pin
22	Shunt+	Positive Current Sense
23	VSS	Logic Ground

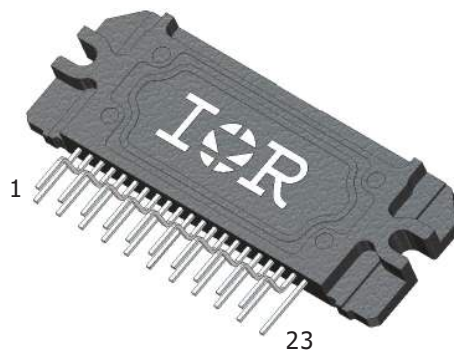

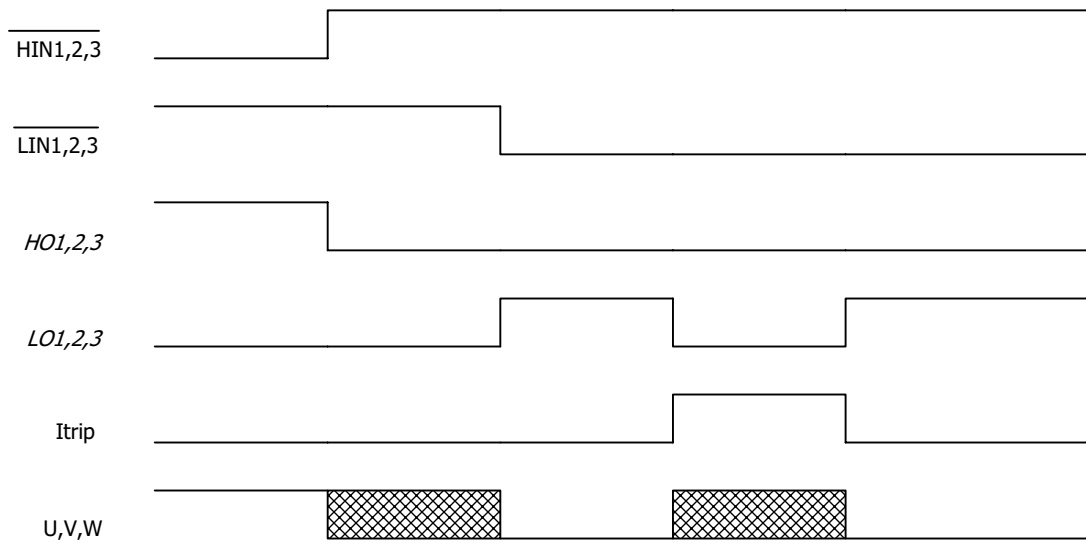
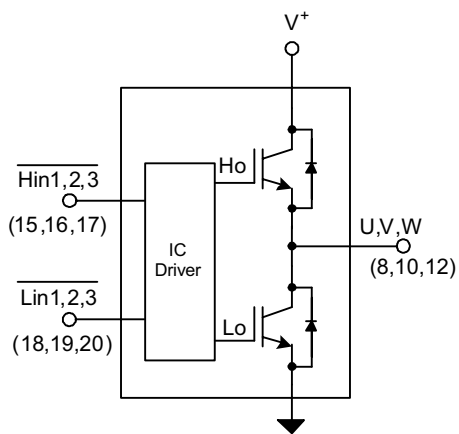

Figure1. Input/Output Timing Diagram

Note 4: The shaded area indicates that both high-side and low-side switches are off and therefore the half-bridge output voltage would be determined by the direction of current flow in the load.

Input-Output Logic Level Table



I_{TRIP}	$\overline{HIN1,2,3}$	$\overline{LIN1,2,3}$	U,V,W
0	0	1	V^+
0	1	0	0
0	1	1	X
1	X	X	X

Typical Application Connection IRAM136-0461G

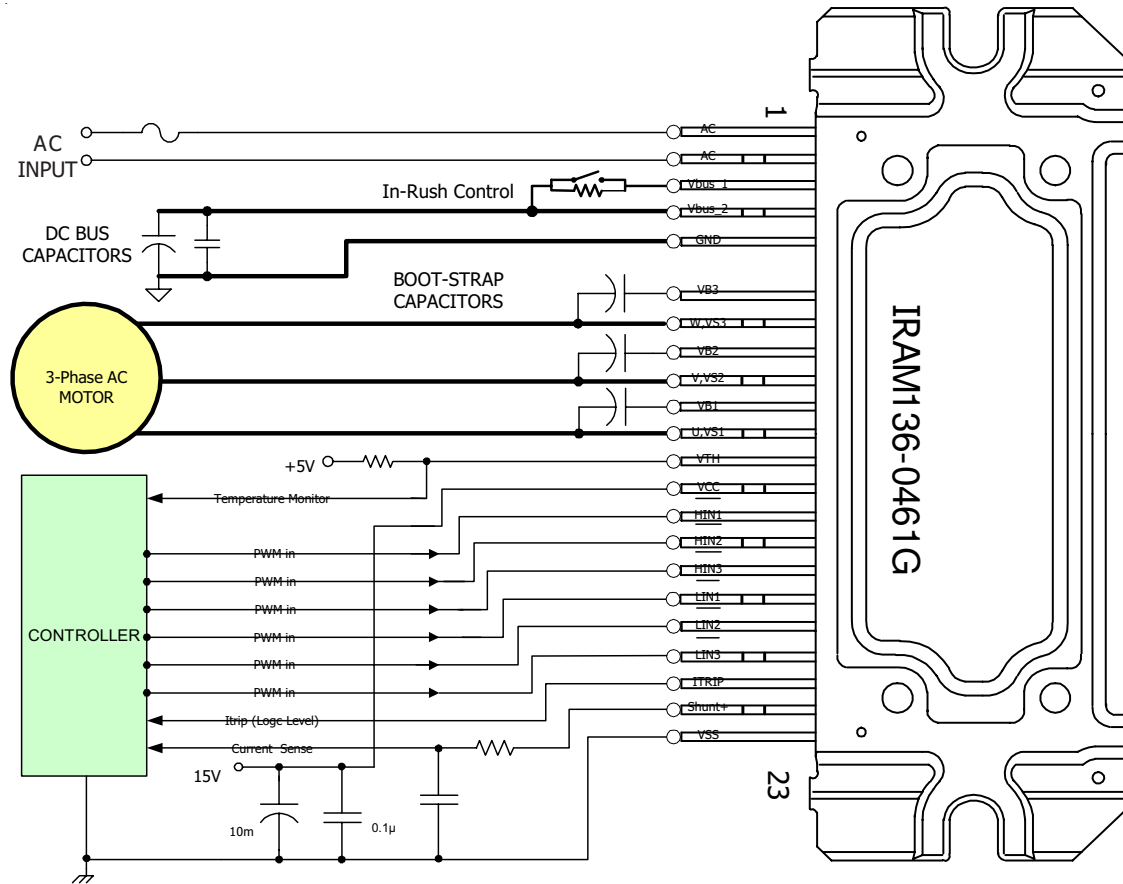

1. Electrolytic bus capacitors should be mounted as close as possible to the module bus terminals to reduce ringing and EMI problems. Additional high frequency ceramic capacitors mounted close to the module pins will improve performance.
2. In order to provide good decoupling between $V_{CC}-V_{SS}$ and V_B-V_S terminals, the capacitors connected between these terminals should be located very close to the module pins. Additional high frequency capacitors, typically $0.1\mu F$, are strongly recommended.
3. Value of the boot-strap capacitors depends upon the switching frequency. Their selection should be made based on IR design tip DN 98-2a, application note AN-1044 or Figure 9.
4. Current sense signal can be obtained from pin 22 and pin 23
5. After approx. 9 ms the FAULT is reset
6. PWM generator must be disabled within Fault duration to guarantee shutdown of the system, and the overcurrent condition must be cleared before resuming operation

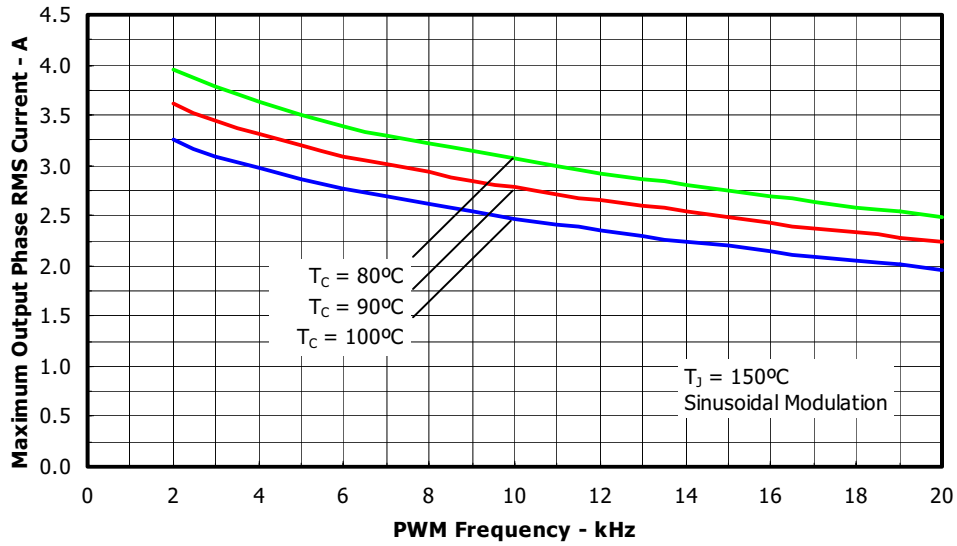

Figure 3. Maximum Sinusoidal Phase Current vs. PWM Switching Frequency
 $V_{BUS}=400V$, $T_J=150^\circ\text{C}$, Modulation Depth=0.8, PF=0.6

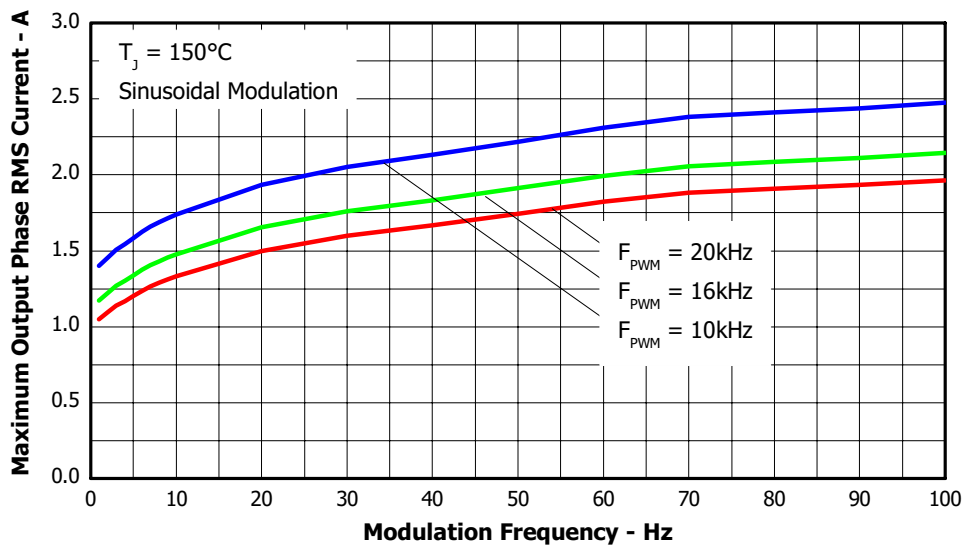

Figure 4. Maximum Sinusoidal Phase Current vs. Modulation Frequency
 $V_{BUS}=400V$, $T_J=150^\circ\text{C}$, $T_C=100^\circ\text{C}$, Modulation Depth=0.8, PF=0.6

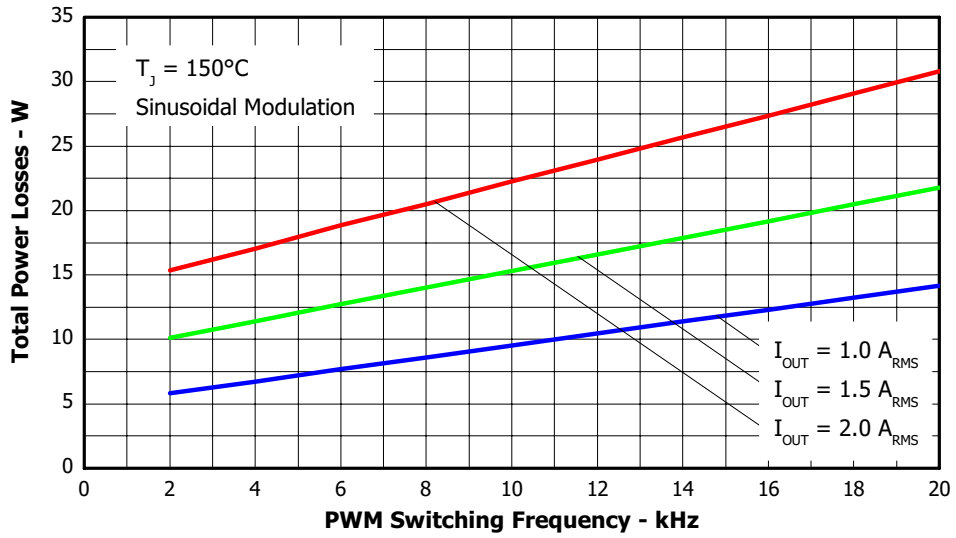

Figure 5. Total Power Losses vs. PWM Switching Frequency, Sinusoidal modulation
 $V_{BUS}=400\text{V}$, $T_j=150^\circ\text{C}$, Modulation Depth=0.8, PF=0.6

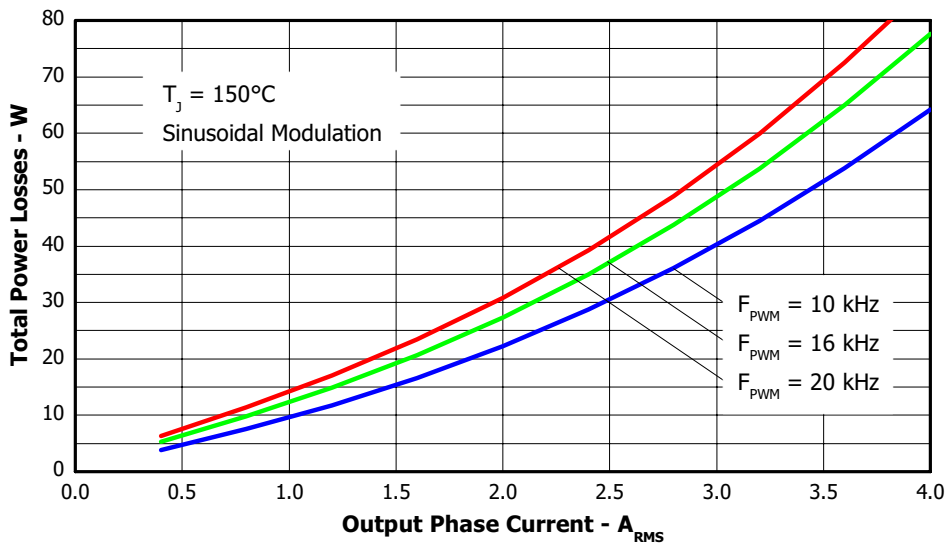

Figure 6. Total Power Losses vs. Output Phase Current, Sinusoidal modulation
 $V_{BUS}=400\text{V}$, $T_j=150^\circ\text{C}$, Modulation Depth=0.8, PF=0.6

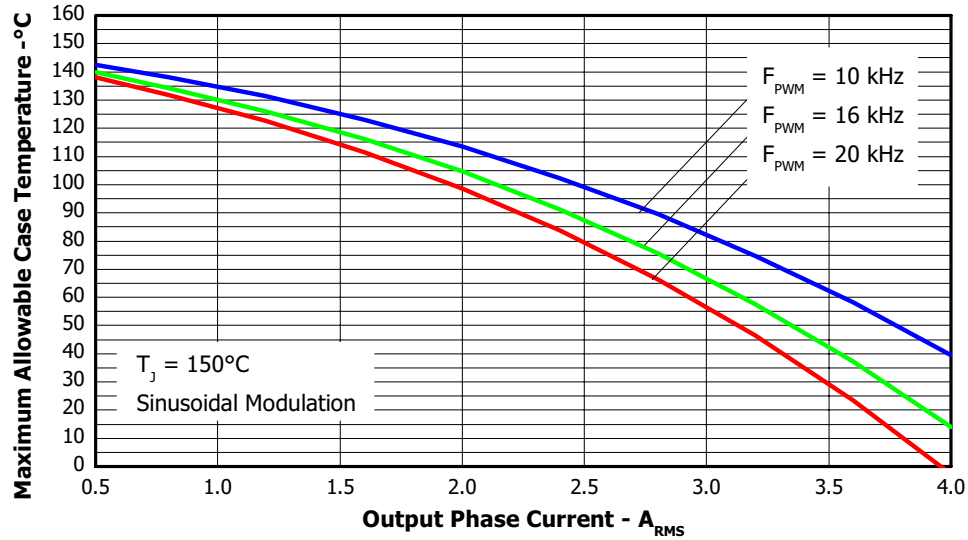

Figure 7. Maximum Allowable Case temperature vs. Output RMS Current per Phase

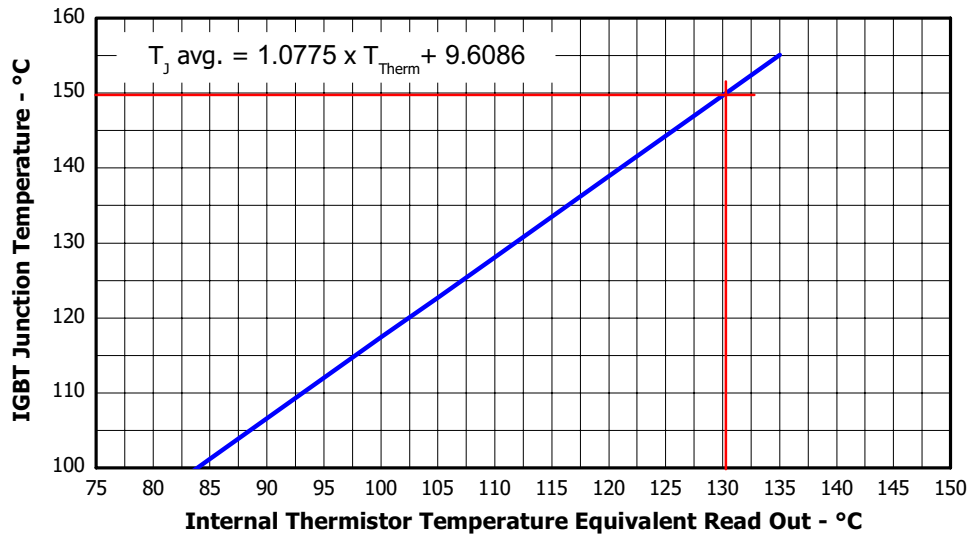

Figure 8. Estimated Maximum IGBT Junction Temperature vs. Thermistor Temperature
 $V_{\text{BUS}}=400\text{V}$, $I_{\text{PHASE}}=1.3\text{A}_{\text{RMS}}$, $F_{\text{PWM}}=16\text{kHz}$

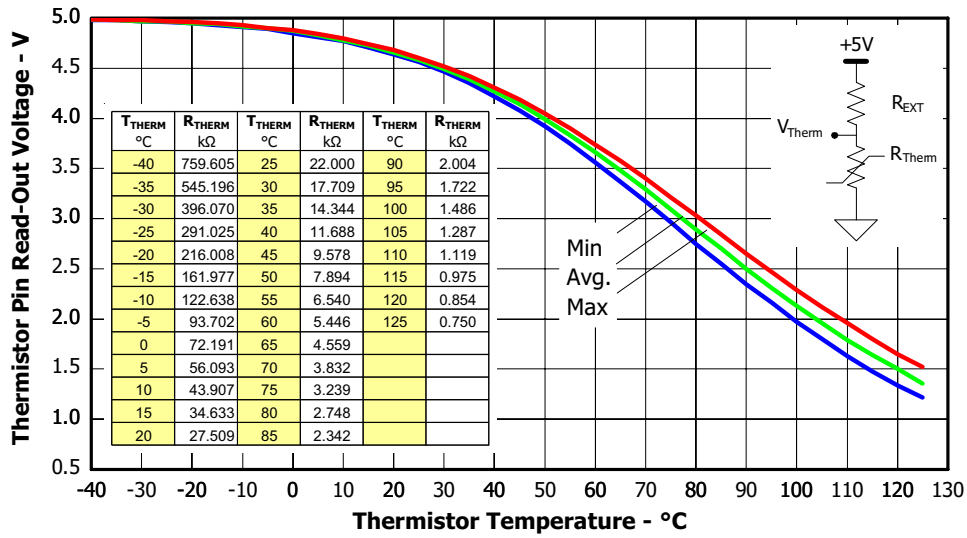

Figure 9. Thermistor Readout vs. Temperature (2kohm pull-up resistor, 5V) and Nominal Thermistor Resistance values vs. Temperature Table.

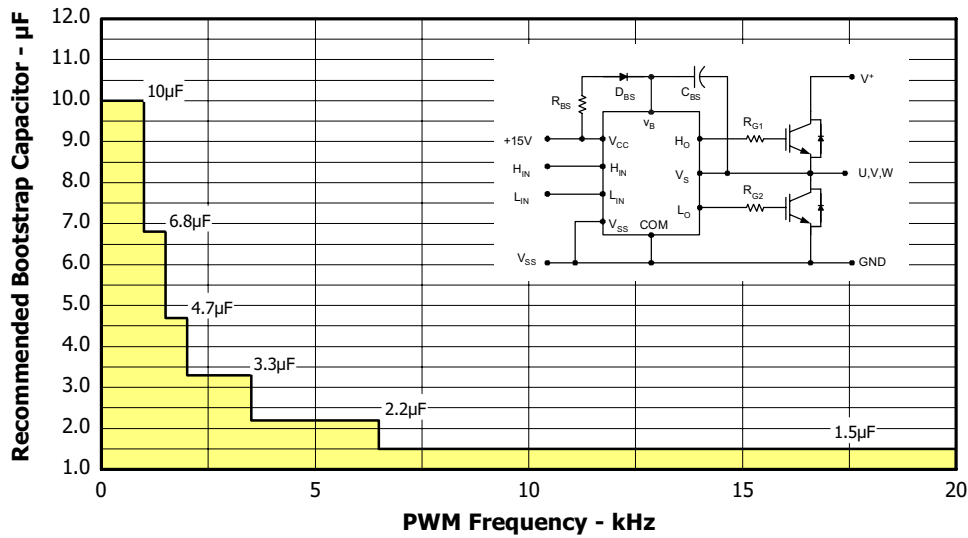

Figure 10. Recommended Bootstrap Capacitor Value vs. Switching Frequency

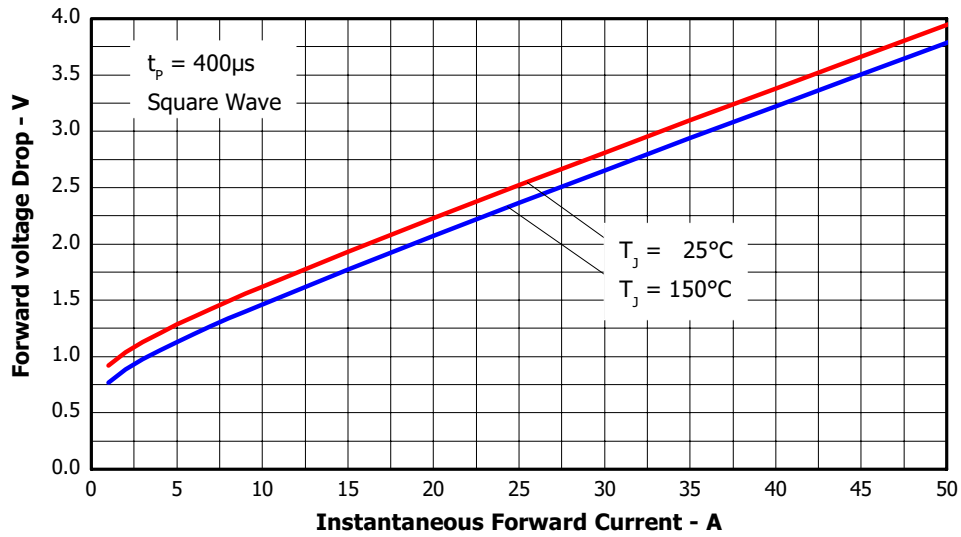

Figure 11. Maximum Forward voltage Drop (Input Bridge Rectifier)

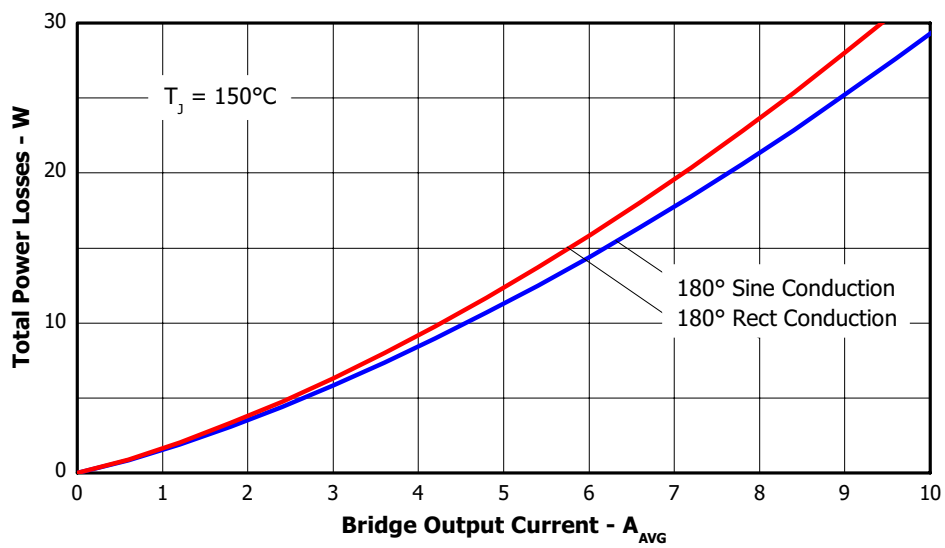

Figure 12. Maximum Power Loss vs. Output Current (Input Bridge Rectifier)

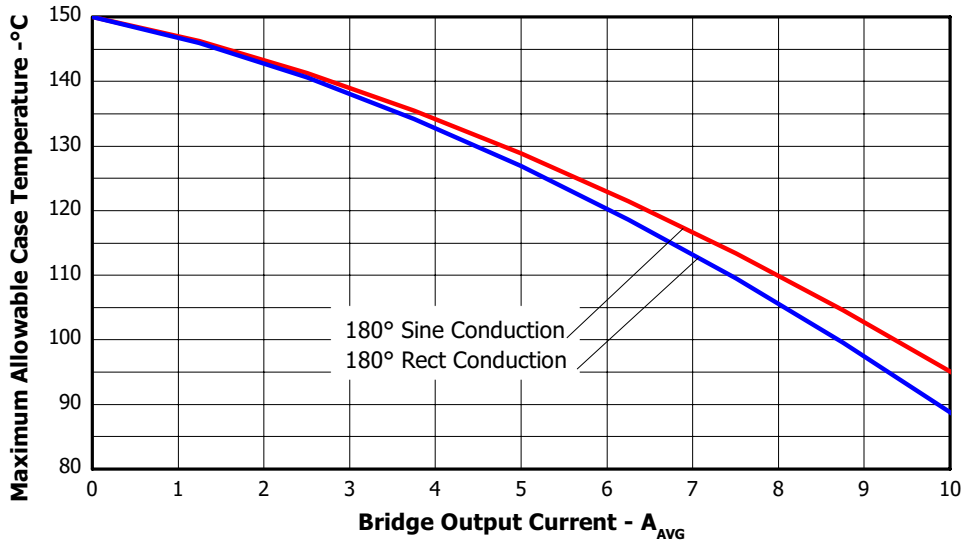

Figure 13. Maximum Allowable Case Temperature vs. Output Current (Input Bridge Rectifier)

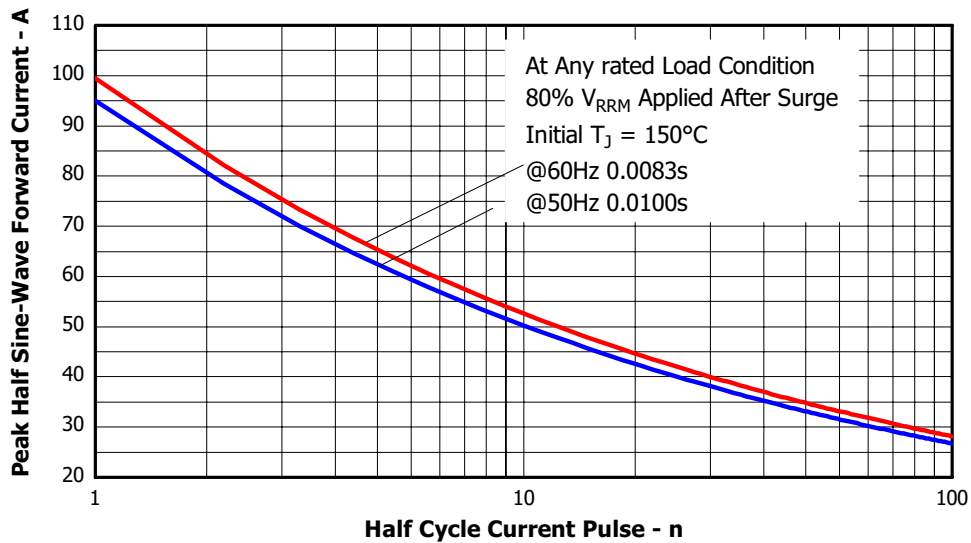

Figure 14. Input Bridge Maximum Non-Repetitive Surge Current

Figure 11. Switching Parameter Definitions

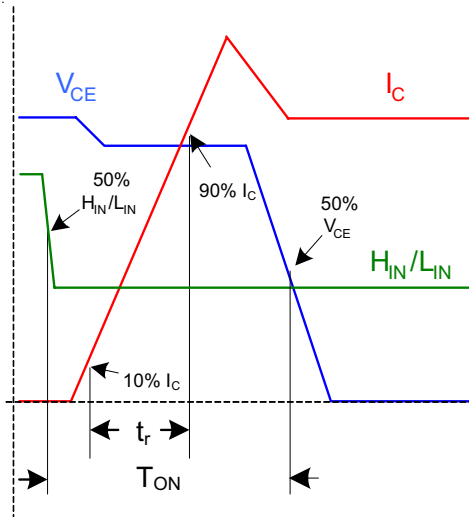

Figure 11a. Input to Output propagation turn-on delay time.

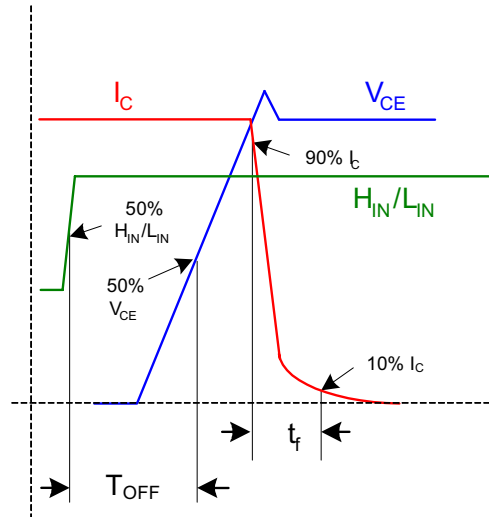

Figure 11b. Input to Output propagation turn-off delay time.

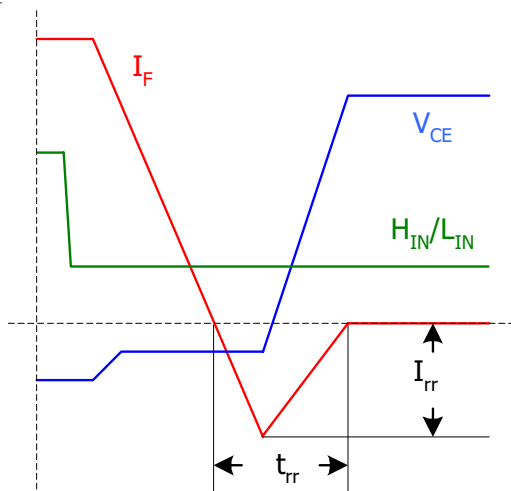

Figure 11c. Diode Reverse Recovery.

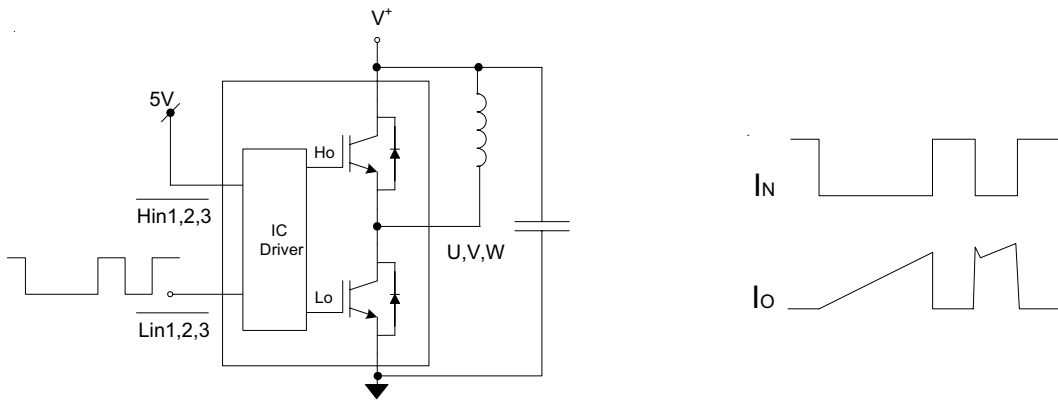

Figure CT1. Switching Loss Circuit

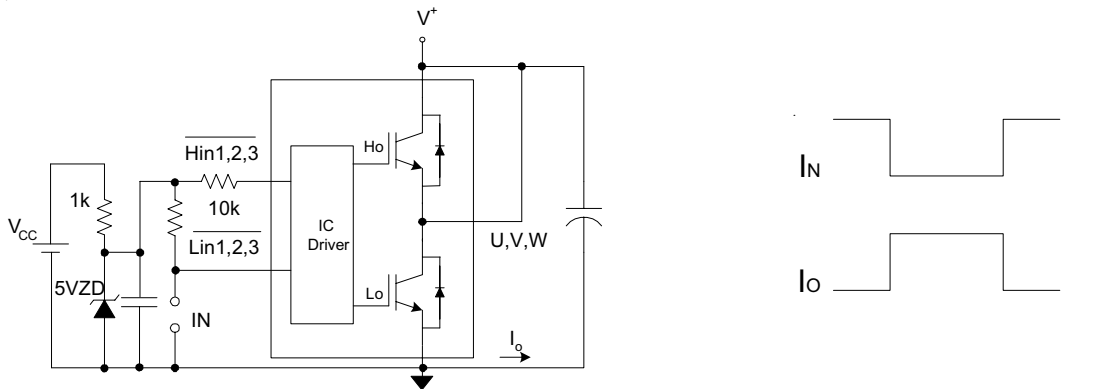

Figure CT2. S.C.SOA Circuit

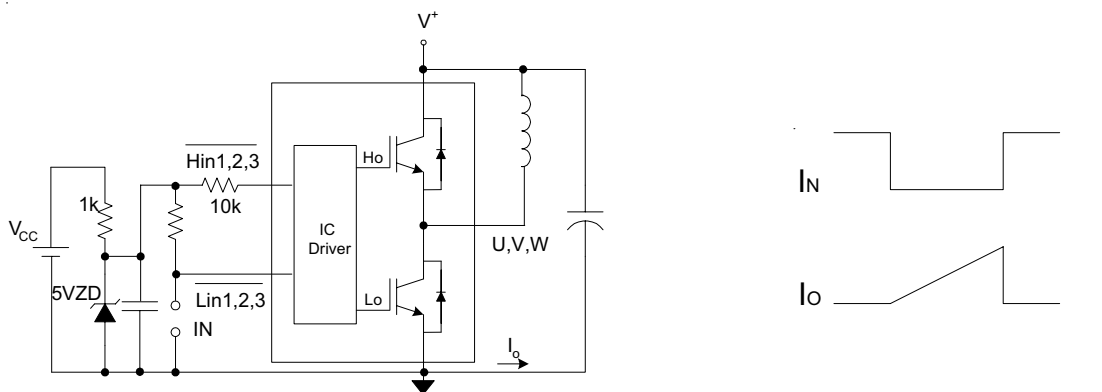
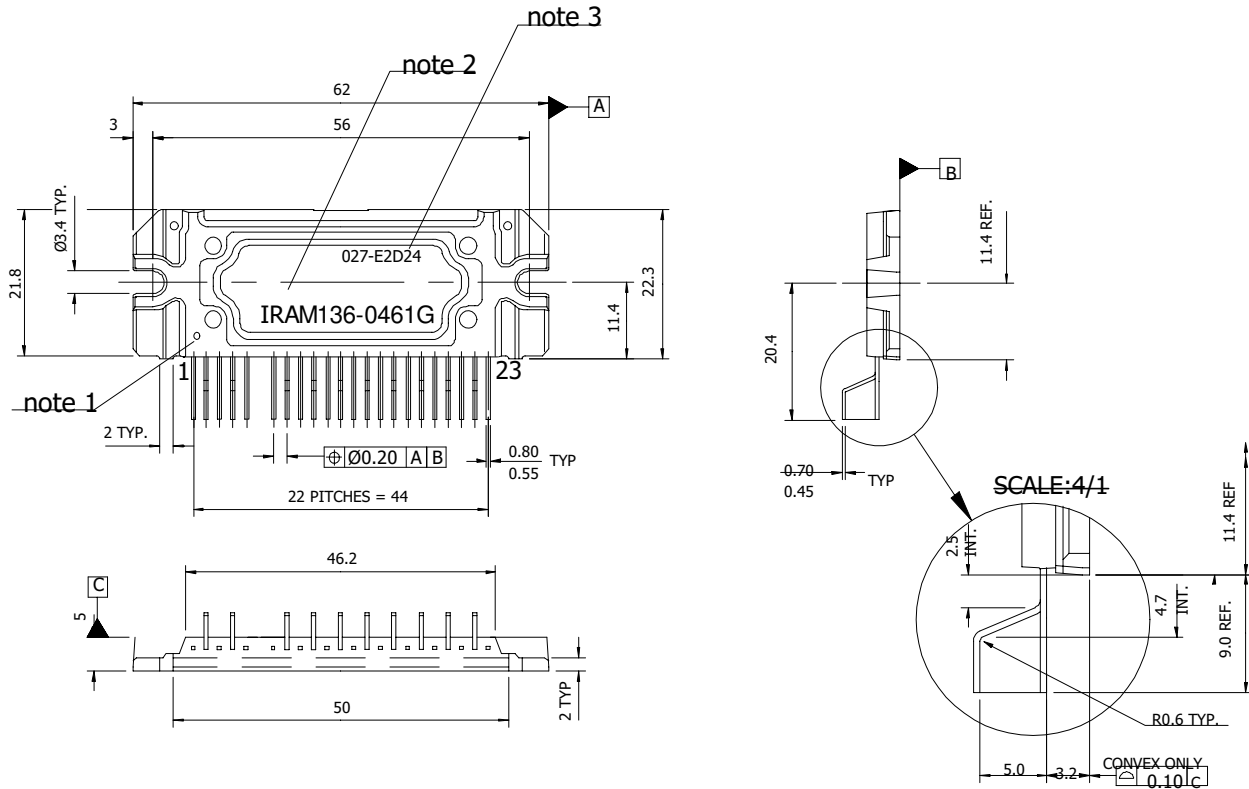

Figure CT3. R.B.SOA Circuit

IRAM136-0461G

Package Outline



Notes:

Dimensions in mm

- 1- Marking for pin 1 identification
- 2- Product Part Number
- 3- Lot and Date code marking

For mounting instruction, see AN1049