

PRODUCT NUMBER(PLATED)	DIM B	DIM L	MATING SOCKET PART NUMBERS	THREADED DEPTH	PRODUCT NUMBER(UNPLATED)
50271-001	.227/5.77	.382/9.70	90306,91506	.165/4.19 MIN.	50271-001U
50271-001LF	.227/5.77	.382/9.70	90306,91506	.165/4.19 MIN.	
50271-002	.296/7.52	.451/11.45	90306,91506	.165/4.19 MIN.	50271-002U
50271-002LF	.296/7.52	.451/11.45	90306,91506	.165/4.19 MIN.	
50271-003	.365/9.27	.520/13.20	90306,91506	.165/4.19 MIN.	50271-003U
50271-003LF	.365/9.27	.520/13.20	90306,91506	.165/4.19 MIN.	
50271-004	.296/7.52	.451/11.45	90306,91506	.250/6.35 MIN.	50271-004U
50271-004LF	.296/7.52	.451/11.45	90306,91506	.250/6.35 MIN.	

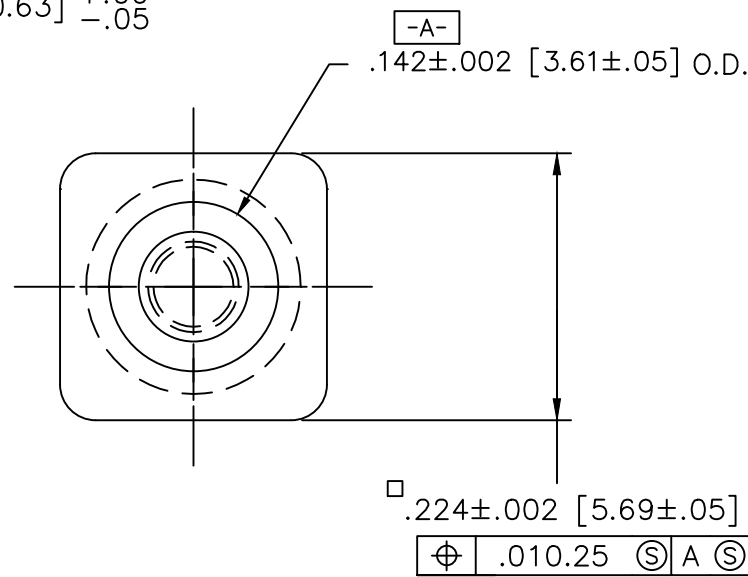
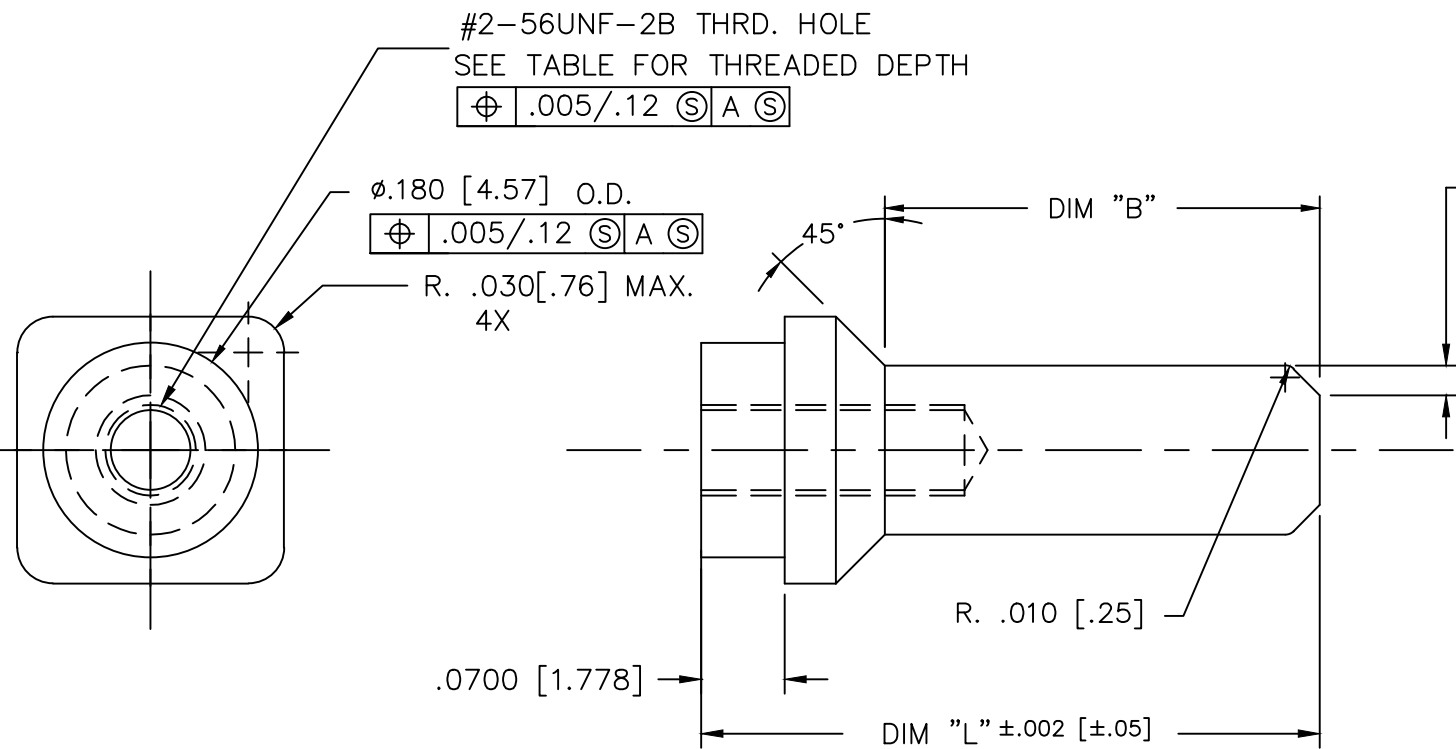

NOTES:

- MATERIAL: PHOS BRONZE
- PLATING: 30u"/.76u MIN Au OVER
50u"/1.27u MIN Ni
- UNSPECIFIED ANGLES - 45°.
- VARIATIONS SHOWN ON THIS PRINT ARE "STANDARD" PIN LENGTHS. SEE P/N 91409 FOR "SPECIAL" PIN LENGTHS.
- SURFACE FINISH IN CONTACT AREA NOT TO EXCEED 25 RMS.
- PRODUCT NUMBERS WITH AN LF SUFFIX MEET EUROPEAN UNION DIRECTIVES AND OTHER COUNTRY REGULATIONS AS DESCRIBED IN GS-22-008.
- THIS PRODUCT IS NOT INTENDED TO BE EXPOSED TO MANUFACTURING SOLDER PROCESSES.

mat'l. code				surface ISO 1302 ✓		tolerance ISO 406 ISO 1101		projection INCH/MM		product family HPC			
ltr				ecn no		dr		date		tolerances unless otherwise specified		title	
L				110-0118		SAL		20/05/10		.XX±.01/.3		POWER PIN SCREW MOUNT	
M				ELX-I-010828		MJA		19/03/12		angles linear .XXX±.005/.13			
N				ELX-I-010932		MJA		22/03/12		0°±2' .xxx±.0020/.051			
-				-		-		-		dr		D. SHEAFFER 3/27/92	
H				V05-0681		DAI		7/20/05		enr		S. CLARK 4/28/92	
J				V05-1072		HTB		11/23/05		chr		S. CLARK 4/28/92	
K				M06-0265		AGS		7/10/06		appd		S. CLARK 4/28/92	
sheet		revision		N									
index		sheet		1									