

SIGN	DATE	DESCRIPTION	APPROVER
△	2012.10.03	USB 2.0 detail added	SHIN

THIS IS CAD DRAWING, DO NOT REVISE MANUALLY!!!

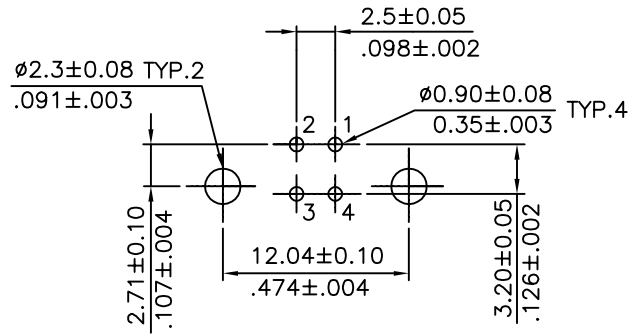
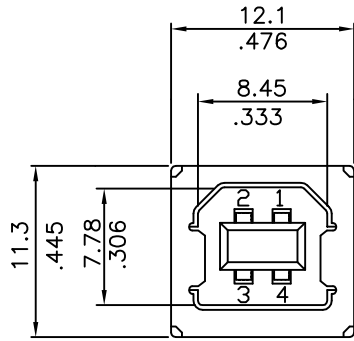

Recommended P.C. Board Layout

Material

- Insulator: Glass Filled Polyester
- Flammability: UL94V-0
- Contacts: Phosphor Bronze
- Contact Plating: See options
- Shell: Brass
- Shell Plating: 100u" Min. Tin over 40u" Nickel

Ratings

- Current: 1A
- Voltage: 30V AC(r.m.s.)
- Dielectric Voltage: 750V AC
- Contact Resistance: <30mΩ
- Insulation Resistance: >1,000 MΩ
- Operating Temperature: 0° - +40°
- Storage Temperature: -40° - +60°

RoHS Compliant

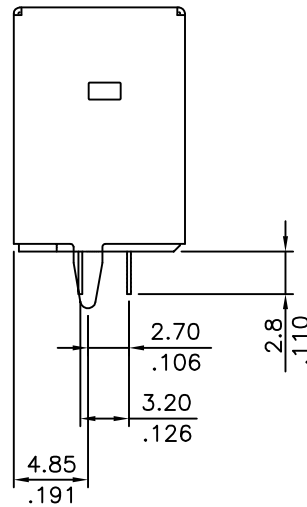
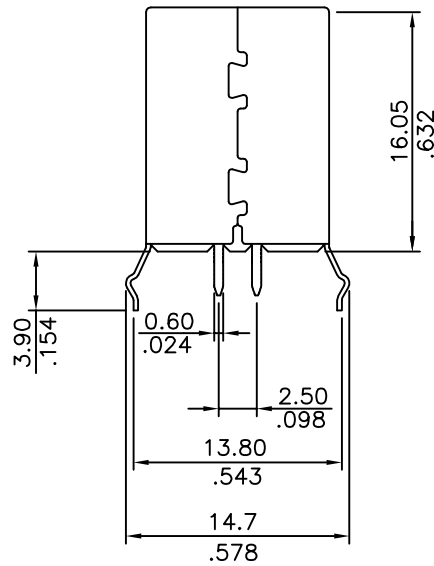

PART NUMBER:

USB-B1VSXX

- COLOR:  
B: Black  
W: White
- PLATING:  
6: Selective Au Flash/50u" Ni  
8: Selective 30u" Au/50u" Ni (USB 2.0)



THESE DRAWINGS AND SPECIFICATIONS ARE THE PROPERTY OF ON-SHORE TECHNOLOGY, INC. AND SHALL NOT BE REPRODUCED, COPIED OR USED IN ANY MANNER WITHOUT THE PRIOR WRITTEN CONSENT OF ON-SHORE TECHNOLOGY, INC.

TITLE		USB - B type, Vertical, thru hole	
PART NO.	USB-B1VSXX	DWG NO.	USB-B1VSXX.DWG
APPROVED	CHECKED	DESIGNED	DRAWN
Steven 2007.03.30	Marvin 2007.03.30	Marvin 2007.03.30	Marvin 2007.03.30
SHEET: 01/01		Tolerance	
UNIT: mm/inches		X.* ±1°	
SCALE: NONE		X.XX ±0.30/.012	
REV.: A		X.XXX ±0.20/.008	
		X.XXX ±0.10/.004	