

REV.	DESCRIPTION	DATE	APPROVED
B	0.027" Lead Hole Specification Update	10/25/04	M. C.
C	0.020" Lead Hole Specification Update	07/18/05	M. C.
D	Updated Model Views	12/08/09	T. Y.
E	Removed Material Code	05/23/16	J. C.

### RL1-XXX

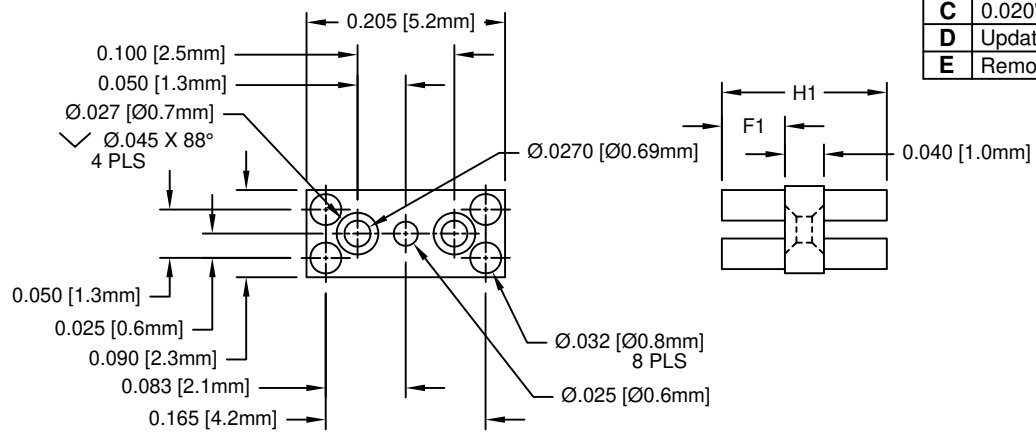

### RL2-XXX

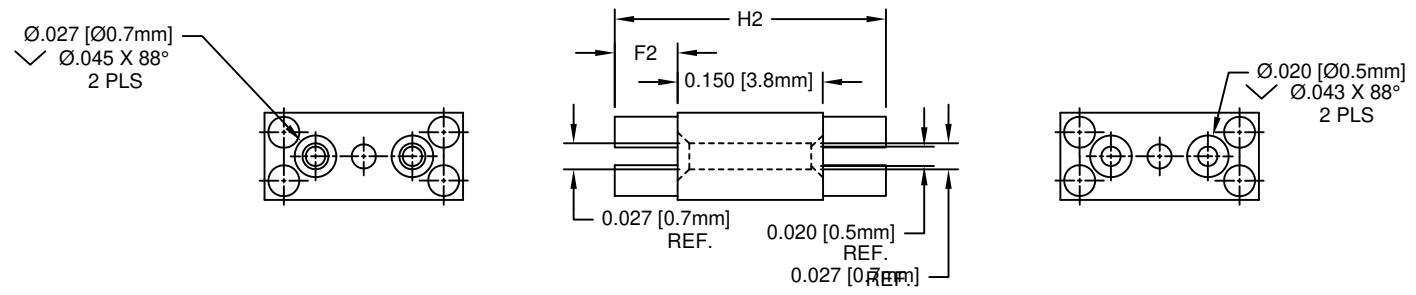

PART NUMBER	H1	F1
RL1-060	.060 (1.5mm)	0.010 (.25mm)
RL1-070	.070 (1.8mm)	0.015 (.38mm)
RL1-080	.080 (2.0mm)	0.020 (.51mm)
RL1-090	.090 (2.3mm)	0.025 (.64mm)
RL1-100	.100 (2.5mm)	0.030 (.76mm)
RL1-110	.110 (2.8mm)	0.035 (.89mm)
RL1-120	.120 (3.0mm)	0.040 (1.0mm)
RL1-130	.130 (3.3mm)	0.045 (1.1mm)
RL1-140	.140 (3.6mm)	0.050 (1.3mm)
RL1-150	.150 (3.8mm)	0.055 (1.4mm)
RL1-160	.160 (4.1mm)	0.060 (1.5mm)
RL1-170	.170 (4.3mm)	0.065 (1.7mm)
RL1-180	.180 (4.6mm)	0.070 (1.8mm)
RL1-190	.190 (4.8mm)	0.075 (1.9mm)
RL1-200	.200 (5.1mm)	0.080 (2.0mm)
RL1-210	.210 (5.3mm)	0.085 (2.2mm)

PART NUMBER	H2	F2
RL2-200	0.200 (5.1mm)	0.025 (.64mm)
RL2-210	0.210 (5.3mm)	0.030 (.76mm)
RL2-220	0.220 (5.6mm)	0.035 (.89mm)
RL2-230	0.230 (5.8mm)	0.040 (1.0mm)
RL2-240	0.240 (6.1mm)	0.045 (1.1mm)
RL2-250	0.250 (6.4mm)	0.050 (1.3mm)
RL2-260	0.260 (6.6mm)	0.055 (1.4mm)
RL2-270	0.270 (6.9mm)	0.060 (1.5mm)
RL2-280	0.280 (7.1mm)	0.065 (1.7mm)
RL2-290	0.290 (7.4mm)	0.070 (1.8mm)
RL2-300	0.300 (7.6mm)	0.075 (1.9mm)
RL2-310	0.310 (7.9mm)	0.080 (2.0mm)
RL2-320	0.320 (8.1mm)	0.085 (2.2mm)
RL2-330	0.330 (8.4mm)	0.090 (2.3mm)
RL2-340	0.340 (8.6mm)	0.095 (2.4mm)
RL2-350	0.350 (8.9mm)	0.100 (2.5mm)

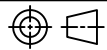
STANDARD TOLERANCE (UNLESS OTHERWISE SPECIFIED) DECIMALS      ANGULAR .X    ± .1      X°   ± 1° .XX   ± .01 .XXX ± .005	 <b>BIVAR</b> <sup>®</sup> 4 THOMAS, IRVINE, CA. 92618 TEL: (949) 951-8808    FAX: (949) 951-3974		
			 <b>TITLE:</b> MOLDED RECTANGULAR LED MOUNT
DESIGNED: <b>M. Chen</b>	DATE: <b>03/11/03</b>	<b>PART NO:</b> RL1-RL2-XXX	REVISION: <b>E</b>
CHECKED: <b>D. Green</b>	DATE: <b>03/11/03</b>	<b>CAGE CODE :</b> 32559	<b>SHEET #</b> 1 OF 1
CAD GENERATED DOCUMENT. DO NOT MEASURE DRAWING.			

- MATERIAL: NYLON 6/6, 94V-0, WHITE.
- GENERAL SPECIFICATIONS: BIVAR MOLDED COMPONENT SPECIFICATION BV00-E101.