

PART NO. SEE CHART
 DWG. NO. SD-90331-001

PART NO.	KEYING RECD. AT CIRCUIT POSITIONS						DIM. A	DIM. B	MIDDLE LOCKING PEG	CKT. SIZE
	1	2	3	4	5	6				
90331-**01	YES	YES	YES	YES	YES	YES	19.81±0.13	23.67±0.13	YES	6
90331-**02	YES	NO	NO	NO	NO	NO	19.81±0.13	23.67±0.13	YES	6
90331-**03	NO	NO	NO	YES	NO	NO	19.81±0.13	23.67±0.13	YES	6
90331-**04	YES	NO	YES	YES	NO	NO	19.81±0.13	23.67±0.13	YES	6
90331-**05	YES	YES	—	—	—	—	3.96±0.10	7.82±0.10	NO	2
90331-**06	NO	NO	NO	NO	NO	NO	19.81±0.13	23.67±0.13	NO	6
90331-**07	NO	YES	NO	NO	NO	NO	19.81±0.13	23.67±0.13	YES	6
90331-**08	NO	NO	YES	NO	NO	NO	19.81±0.13	23.67±0.13	YES	6
90331-**09	NO	NO	NO	NO	YES	NO	19.81±0.13	23.67±0.13	YES	6
90331-**10	NO	NO	NO	NO	NO	YES	19.81±0.13	23.67±0.13	YES	6

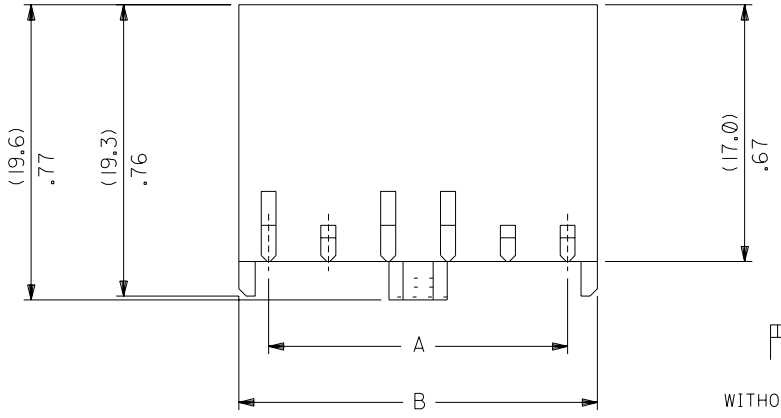

LEGEND :

90331- * * 0 *

COLOUR — 0=NATURAL
 1=BLACK (AVAILABLE IN NYLON ONLY)

MATERIAL — 0=POLYESTER 94 V0-NATURAL(WHITE)
 1=NYLON 6/6 UL 94 V0-NATURAL(WHITE) OR BLACK
 4=NYLON 6/6 UL 94 V2-NATURAL OR BLACK

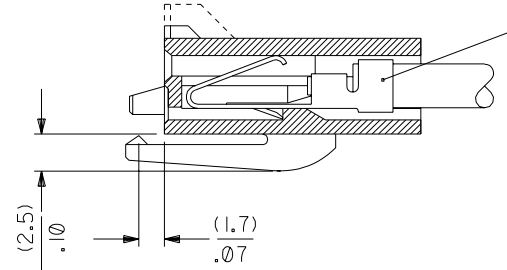
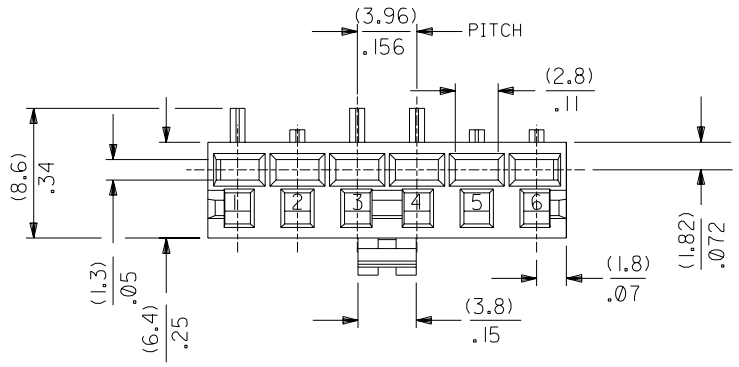

PART NO. 08-50-0277
 MATERIAL: PRE-TIN BRASS
 PLATING TO P902 CODE PER ES-88
 SPECIFICATION.

NOTES :

- HOUSING MATERIAL: SEE LEGEND. NYLON OPTIONS ARE FOR TAIWAN PRODUCTION ONLY.
- FOR USE WITH 8993 SERIES TERMINAL.
- KEY IS OPTIONAL. PLS SEE TABLE FOR P/N.
- FOR ILLUSTRATION PURPOSE, 90331-004 IS SHOWN
- PRODUCT SPECIFICATION: PS-90331

CHANGED PLATING CODES EC NO. E2004-0036 DRWN: PSHEAHAN 03/07/14 CHK: APPR:	QUALITY SYMBOLS MAJOR \blacktriangledown = 0 CRITICAL ∇ = 0	GENERAL TOLERANCES: (UNLESS SPECIFIED)	SCALE 3:1 DESIGN UNITS <input checked="" type="checkbox"/> mm <input type="checkbox"/> INCH	THIRD ANGLE PROJECTION <input checked="" type="checkbox"/> mm <input type="checkbox"/> INCH <input type="checkbox"/> mm ONLY	DIMENSIONS:	SHT 2 REV V	
	DRAWN BY & DATE CD 9/12/18	4 PLACES ±0. ±.005 3 PLACES ±0. ±.010 2 PLACES ±0.13 ±. 1 PLACE ±0.25 ±.	CHECKED BY & DATE	APPROVED BY & DATE	TITLE: HOUSING 3.96 PITCH CORING OPTION 1 FOR USE W/ 8993 TERMINAL	INCH <input type="checkbox"/> mm <input type="checkbox"/> mm ONLY	CAD FILENAME S90331EX1.DGN
	MATERIAL NO. SEE CHART DRAWING NO. SD-90331-001	ANGULAR: ± 1/2 °	DRAFT WHERE APPLICABLE MUST REMAIN WITHIN DIMENSIONS	THIS DRAWING CONTAINS INFORMATION THAT IS PROPRIETARY TO MOLEX INCORPORATED AND SHOULD NOT BE USED WITHOUT WRITTEN PERMISSION.	MOLEX INCORPORATED	SHEET NO. IOF2	SIZE B
	REV V	DESCRIPTION	THIS DRAWING CONTAINS INFORMATION THAT IS PROPRIETARY TO MOLEX INCORPORATED AND SHOULD NOT BE USED WITHOUT WRITTEN PERMISSION.	THIS DRAWING CONTAINS INFORMATION THAT IS PROPRIETARY TO MOLEX INCORPORATED AND SHOULD NOT BE USED WITHOUT WRITTEN PERMISSION.	MOLEX INCORPORATED	SHEET NO. IOF2	SIZE B

PART NO. SEE CHART
 DWG. NO. SD-90331-001

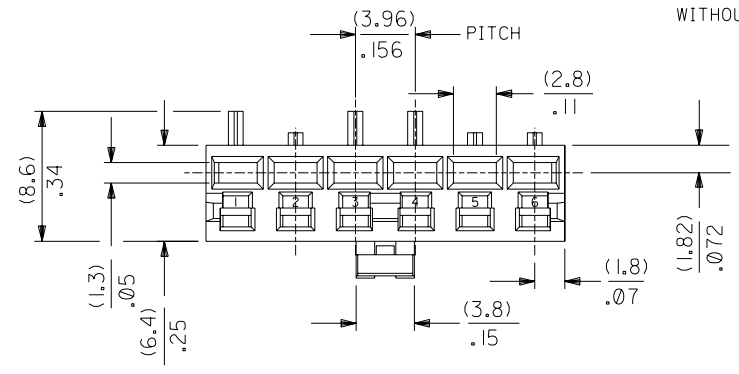
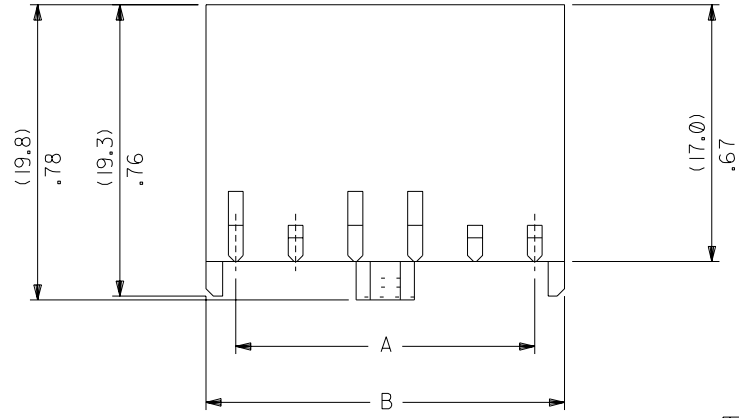

WITHOUT KEYING

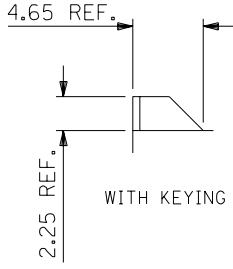

LEGEND :

90331- * * 0 *

COLOUR — 0=NATURAL
 1=BLACK (AVAILABLE IN NYLON ONLY)

MATERIAL — 0=POLYESTER 94 V0-NATURAL(WHITE)
 1=NYLON 6/6 UL 94 V0-NATURAL(WHITE) OR BLACK
 4=NYLON 6/6 UL 94 V2-NATURAL OR BLACK

PART NO.	KEYING REQD. AT CIRCUIT POSITIONS						DIM. A	DIM. B	MIDDLE LOCKING PEG	CKT. SIZE
	1	2	3	4	5	6				
90331-**01	YES	YES	YES	YES	YES	YES	19.81±0.13	23.67±0.13	YES	6
90331-**02	YES	NO	NO	NO	NO	NO	19.81±0.13	23.67±0.13	YES	6
90331-**03	NO	NO	NO	YES	NO	NO	19.81±0.13	23.67±0.13	YES	6
90331-**04	YES	NO	YES	YES	NO	NO	19.81±0.13	23.67±0.13	YES	6
90331-**05	YES	YES	—	—	—	—	3.96±0.10	7.82±0.10	NO	2
90331-**06	NO	NO	NO	NO	NO	NO	19.81±0.13	23.67±0.13	NO	6
90331-**07	NO	YES	NO	NO	NO	NO	19.81±0.13	23.67±0.13	YES	6
90331-**08	NO	NO	YES	NO	NO	NO	19.81±0.13	23.67±0.13	YES	6
90331-**09	NO	NO	NO	NO	YES	NO	19.81±0.13	23.67±0.13	YES	6
90331-**10	NO	NO	NO	NO	NO	YES	19.81±0.13	23.67±0.13	YES	6

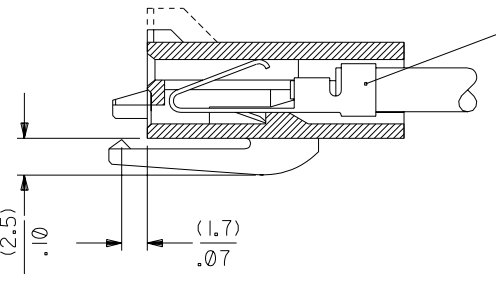

PART NO. 08-50-0277
 MATERIAL: PRE-TIN BRASS
 PLATING TO P902 CODE PER ES-88
 SPECIFICATION.

- NOTES :
- HOUSING MATERIAL: SEE LEGEND. NYLON OPTIONS ARE FOR TAIWAN PRODUCTION ONLY.
 - FOR USE WITH 8993 SERIES TERMINAL.
 - KEY IS OPTIONAL. PLS SEE TABLE FOR P/N.
 - FOR ILLUSTRATION PURPOSE, 90331-**04 IS SHOWN
 - PRODUCT SPECIFICATION: PS-90331

CHANGED PLATING CODES EC NO. E2004-0036 DRWN: PSHEAHAN 03/07/14 CHK: / / / APPR: / / /	QUALITY SYMBOLS MAJOR \blacktriangledown = 0 CRITICAL \blacktriangledown = 0	GENERAL TOLERANCES: (UNLESS SPECIFIED)		SCALE	DESIGN UNITS	THIRD ANGLE PROJECTION	DIMENSIONS:		SHT	REV
		mm	INCH	<input checked="" type="checkbox"/> mm <input type="checkbox"/> INCH	<input checked="" type="checkbox"/> mm <input type="checkbox"/> INCH	<input checked="" type="checkbox"/> mm <input type="checkbox"/> INCH	<input type="checkbox"/> mm <input type="checkbox"/> INCH			
REV	DESCRIPTION	4 PLACES ±0. ±.		DRAWN BY & DATE FM 94/02/21		TITLE: HOUSING 3.96 PITCH CORING OPTION 2, FOR USE W/ 8993 SERIES TERMINAL				
		3 PLACES ±0. ±.005		CHECKED BY & DATE						
		2 PLACES ±0.13 ±.010		APPROVED BY & DATE		MOLEX INCORPORATED				
		1 PLACE ±0.25 ±.		CAD FILENAME						
		ANGULAR: ± °		S90331EX2.DGN		SEE CHART	SD-90331-001	2 OF 2		
DRAFT WHERE APPLICABLE MUST REMAIN WITHIN DIMENSIONS										
THIS DRAWING CONTAINS INFORMATION THAT IS PROPRIETARY TO MOLEX INCORPORATED AND SHOULD NOT BE USED WITHOUT WRITTEN PERMISSION.										