



USB Downstream Port Terminator with VBUS ESD Protection

PACUSBVB-D1/D2/D3

Features

- A low-capacitance USB downstream port terminator, EMI filter, and transient over-voltage protector in a single surface-mounted package
- ESD protection to $\pm 20\text{kV}$ contact discharge, per MIL-STD-883D, Method 3015
- ESD protection to $\pm 15\text{kV}$ contact discharge, per IEC 61000-4-2 International Standard
- Provides ESD protection for the VBUS line
- Compact SOT23-6 package saves board space and lowers manufacturing costs compared to discrete solutions
- Capacitors matched to a precision exceeding the USB specification
- Lead-free versions available

Applications

- ESD protection and termination of USB downstream ports
- Desktop PCs
- Notebooks
- Set-top boxes
- USB hubs

Product Description

The PACUSBVB-D1/D2/D3 is a single-channel USB downstream-port termination network. It integrates EMI/RFI filter components R1 and C1 as recommended by the USB specification, as well as the required $15\text{k}\Omega$ pull-down resistors (R2) to GND. In addition, PACUSBVB-D1/D2/D3 provides a very high level of protection for sensitive electronic components that may be subjected to electrostatic discharge (ESD). The device pins will safely dissipate ESD strikes of $\pm 15\text{kV}$, exceeding the maximum requirements of the IEC 61000-4-2 international standard. Using the MIL-STD-883D (Method 3015) specification for Human Body Model (HBM) ESD, all pins are protected from contact discharges to $\pm 20\text{kV}$. The PACUSBVB-D1/D2/D3 also features a fifth zener diode (cathode at pin 5) which provides ESD protection for the USB VBUS line.

There are three options for the value of the series resistor R1: 15Ω , 33Ω , and 22Ω . This series resistance, plus the USB driver output resistance, must be close to the USB cable's characteristic impedance of 45Ω (each side) to minimize transmission line reflections.

The PACUSBVB-D1/D2/D3 is housed in a 6-pin SOT23 package and is available with optional lead-free finishing.

Electrical Schematic

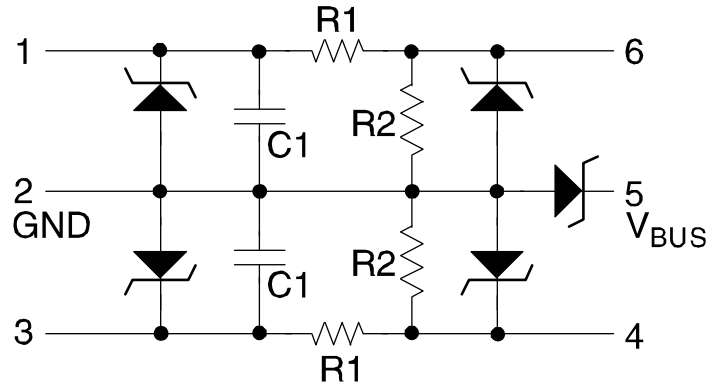

Top View

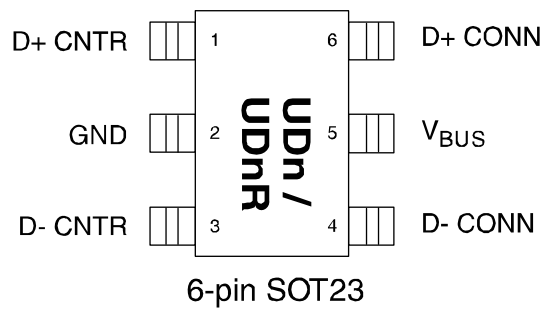

Note 1: The "n" shown in part markings above represents either the digit "1," "2," or "3."
 Note 2: These drawings are not to scale.

PIN DESCRIPTIONS

PINS	NAME	DESCRIPTION
1	D+ CNTR	D+ Data to the USB controller circuitry
2	GND	Ground Pin
3	D- CNTR	D- Data to the USB controller circuitry
4	D- CONN	D- Data to the USB connector
5	V _{BUS}	V _{BUS} input pin
6	D+ CONN	D+ Data to the USB connector

Ordering Information

PART NUMBERING INFORMATION						
Pins	R1 Value	Package	Standard Finish		Lead-free Finish	
			Ordering Part Number ¹	Part Marking	Ordering Part Number ¹	Part Marking
6	15 Ω	SOT23-6	PACUSBVB-D2Y6	UD2	PACUSBVB-D2Y6R	UD2R
	22 Ω		PACUSBVB-D3Y6	UD3	PACUSBVB-D3Y6R	UD3R
	33 Ω		PACUSBVB-D1Y6	UD1	PACUSBVB-D1Y6R	UD1R

Note 1: Parts are shipped in Tape & Reel form unless otherwise specified.

Specifications

ABSOLUTE MAXIMUM RATINGS		
PARAMETER	RATING	UNITS
Storage Temperature Range	-65 to +150	$^{\circ}\text{C}$
Power Dissipation per Resistor	100	mW
Package Power Dissipation	200	mW
Voltage on any pin (DC)	6	V

STANDARD OPERATING CONDITIONS		
PARAMETER	RATING	UNITS
Operating Temperature	-40 to +85	$^{\circ}\text{C}$
V_{BUS} Input Voltage	5	V

ELECTRICAL OPERATING CHARACTERISTICS

SYMBOL	PARAMETER	CONDITIONS	MIN	TYP	MAX	UNITS
R1	Resistance of R1 Resistor (PACUSBVB-D2Y6/Y6R)	$T_A = 25^\circ\text{C}$	12	15	18	Ω
R1	Resistance of R1 Resistor (PACUSBVB-D3Y6/Y6R)	$T_A = 25^\circ\text{C}$	17.6	22	26.4	Ω
R1	Resistance of R1 Resistor (PACUSBVB-D1Y6/Y6R)	$T_A = 25^\circ\text{C}$	26.4	33	39.6	Ω
R2	Resistance of R2 Resistor	$T_A = 25^\circ\text{C}$		15		$\text{k}\Omega$
TCR	Temperature Coefficient of Resistance			± 1300		$\text{ppm}/^\circ\text{C}$
C1	Capacitance of C1 Capacitor	0 VDC; 30 mVAC; 1MHz; 25°C	37.6	47	56.4	pF
		2.5 VDC; 30 mVAC; 1MHz; 25°C	25.6	32	38.4	pF
TOL_{CM}	Matching Tolerance of C1 Capacitors	1MHz; 25°C			± 2	%
I_{LEAK}	Diode Leakage Current to GND	Measured at 3.3 VDC, 25°C		1	100	nA
V_{RB}	Diode Reverse Bias Voltage	$I_{\text{LOAD}} = 10\mu\text{A}$; $T_A = 25^\circ\text{C}$	5.5			V
V_{SIG}	Signal Voltage: Positive Clamp Negative Clamp	$I_{\text{LOAD}} = 10\text{mA}$; $T_A = 25^\circ\text{C}$	5.6	6.8	9.0	V
		$I_{\text{LOAD}} = 10\text{mA}$; $T_A = 25^\circ\text{C}$	-0.4	-0.8	-1.5	V
V_{ESD}	In-system ESD Withstand Voltage MIL-STD-883D, Method 3015 (HBM) IEC 61000-4-2 Contact Discharge	Pins 1, 3; Notes 1 and 2	± 4			kV
		Pins 4, 5; Note 1	± 20			kV
		Pins 4, 5; Note 1	± 15			kV
V_{CL}	Clamping voltage under ESD discharge	MIL-STD-883D, Method 3015 +8kV; Note 3		12		V
		MIL-STD-883D, Method 3015 -8kV; Note 3		-7		V

Note 1: ESD voltage applied to pins with respect to GND, one at a time; unused pins are left open.

Note 2: Pins 1 and 3 are not connected to the USB port connector, and therefore are not exposed to external ESD hazards. Thus, they do not require the high ESD protection levels provided for pins 4, 5, and 6.

Note 3: ESD Clamping Voltage is measured at the opposite end of R1 from the pin to which the ESD discharge is applied (e.g., if ESD is applied to pin 6, then the clamping voltage is measured at pin 1).

Performance Information

Capacitance vs. Voltage

The C1 capacitance value as a function of DC voltage across it is presented in [Diode Capacitance vs. DC Voltage \(Normalized\)](#). The curve is normalized to a capacitance of 1.0 capacitance units at 2.5 VDC.

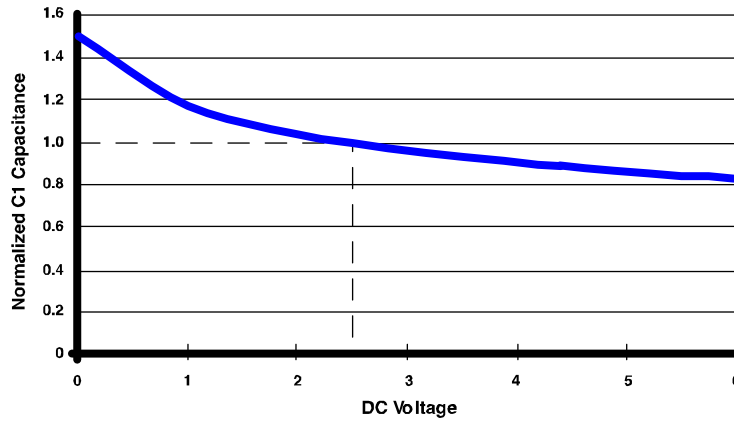

Figure 1. Diode Capacitance vs. DC Voltage (Normalized)

Insertion Loss vs. Frequency Characteristics

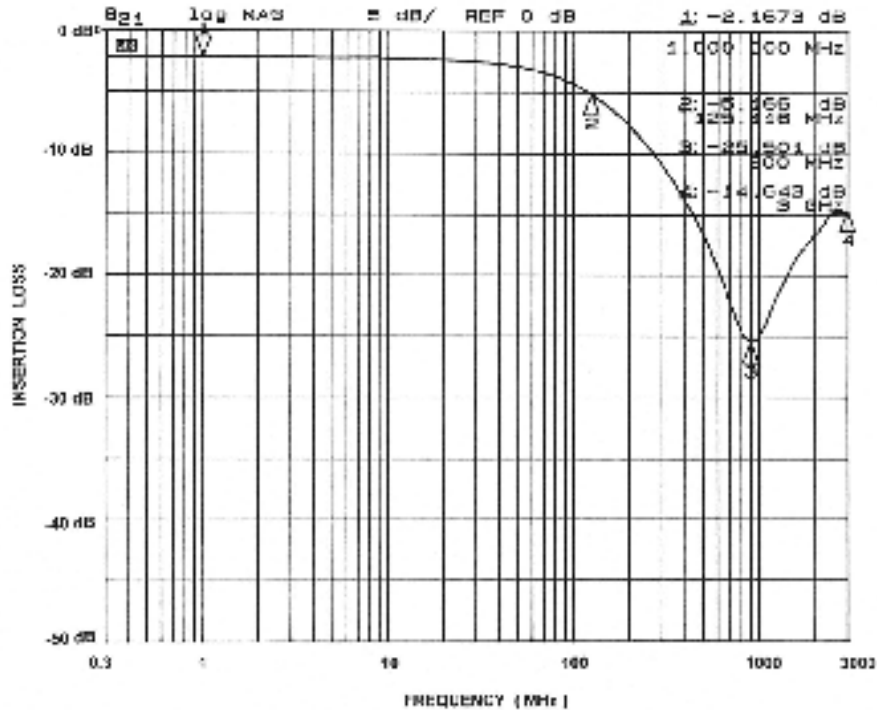

Figure 2. Insertion Loss vs. Frequency Performance Curve, PACUSBVBD1 (SOT23-6)

Performance Information (cont'd)

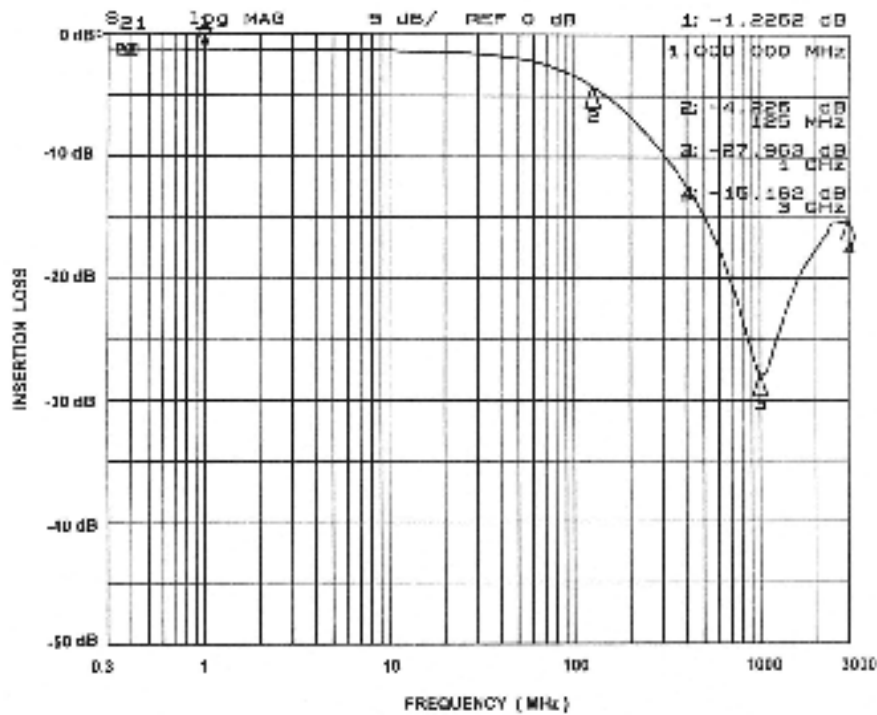
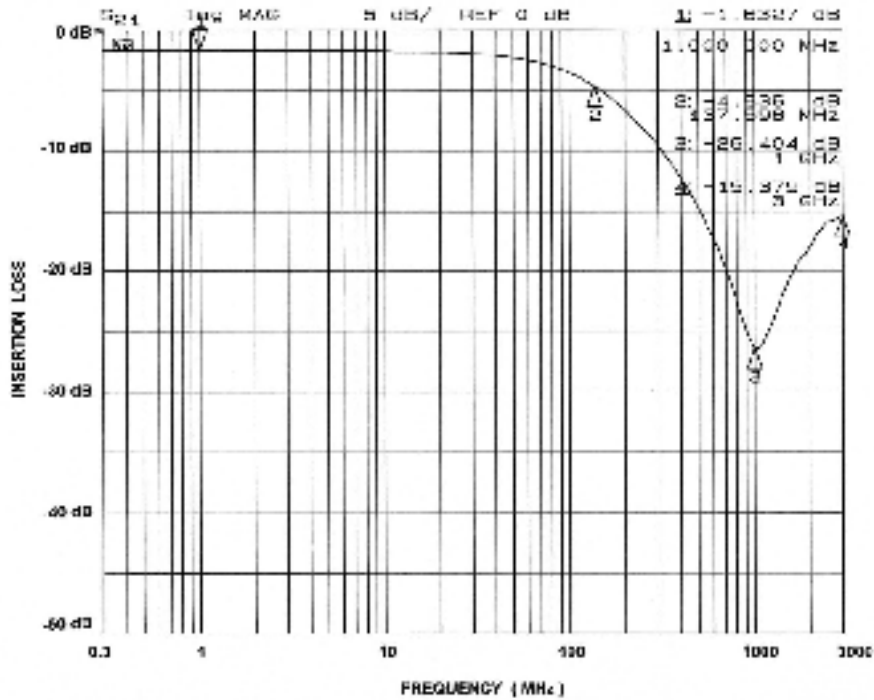

Figure 3. Insertion Loss vs. Frequency Performance Curve, PACUSBVBD2 (SOT23-6)



6)

Figure 4. Insertion Loss vs. Frequency Performance Curve, PACUSBVBD3 (SOT23-6)

Application Information

The PACUSBVB-D1/D2/D3 provides a complete interface for a single downstream USB port typically found in computers and USB hubs. It integrates the series resistors (R1) and the 15kΩ pull-down resistors (R2) for both USB data lines (D+ and D-) as well as the capacitors to ground for EMI suppression. Zener diodes provide ESD protection up to 15kV contact discharge per the IEC 61000-4-2 standard and protect the USB controller on both data lines. The 6-lead PACUSBVB-D1/D2/D3 device provides an additional zener diode to protect the VBUS USB power line.

The PACUSBVB-D1/D2/D3 should be placed on the PCB between the USB controller and the USB connector, as shown on the Connection Diagram [Connection Diagram for PACUSBVB-D1/D2/D3](#).

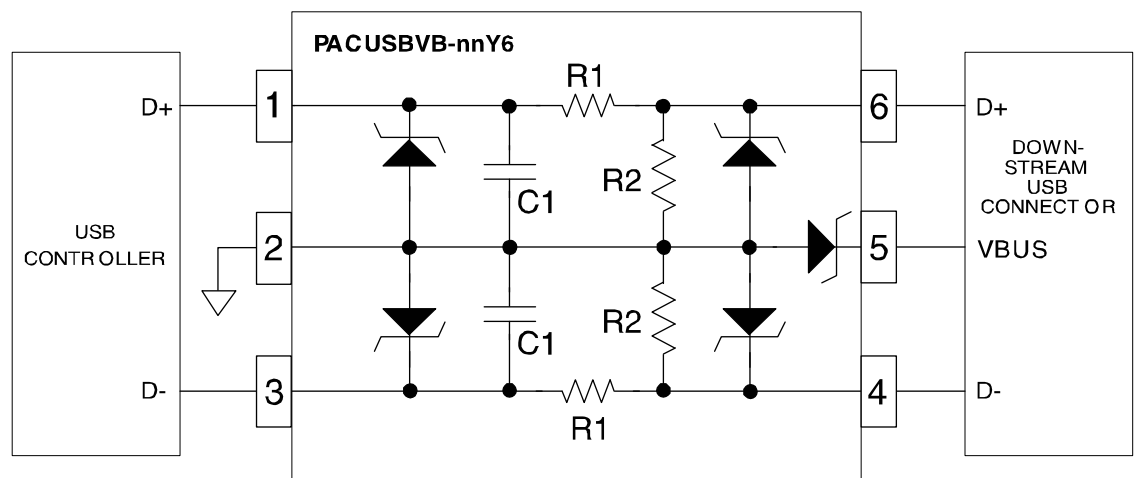

Figure 5.
Connection Diagram for PACUSBVB-D1/D2/D3

To guarantee the best ESD and filtering performance, it is recommended that the PACUSBVB-D1/D2/D3 be located close to the USB connector. Also, the trace lengths between the PACUSBVB-D1/D2/D3 and the USB controller should be kept as short as possible.

Mechanical Details

SOT23-6 Mechanical Specifications:

Dimensions for the PACUSBVB-D1/D2/D3 supplied in a 6-pin SOT23 package are presented below. For complete information on the SOT23-6, see the California Micro Devices SOT23 Package Information document.

PACKAGE DIMENSIONS				
Package	SOT23-6 (JEDEC name is MO-178)			
Pins	6			
Dimensions	Millimeters		Inches	
	Min	Max	Min	Max
A	--	1.45	--	0.057
A1	0.00	0.15	0.000	0.006
b	0.30	0.50	0.012	0.020
c	0.08	0.22	0.003	0.009
D	2.75	3.05	0.108	0.120
E	2.60	3.00	0.102	0.118
E1	1.45	1.75	0.057	0.069
e	0.95 BSC		0.0374 BSC	
e1	1.90 BSC		0.0748 BSC	
L	0.30	0.60	0.012	0.024
L1	0.60 REF		0.024 REF	
# per tape and reel	3000 pieces*			
Controlling dimension: millimeters				

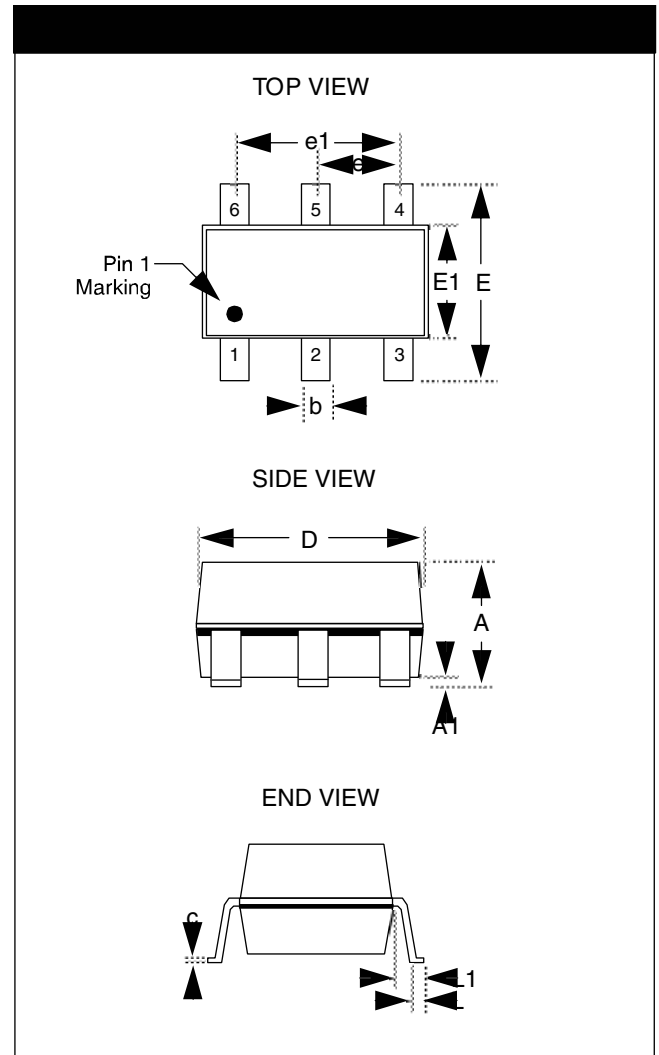

Package Dimensions for SOT23-6

* This is an approximate amount which may vary.

ON Semiconductor and  are registered trademarks of Semiconductor Components Industries, LLC (SCILLC). SCILLC reserves the right to make changes without further notice to any products herein. SCILLC makes no warranty, representation or guarantee regarding the suitability of its products for any particular purpose, nor does SCILLC assume any liability arising out of the application or use of any product or circuit, and specifically disclaims any and all liability, including without limitation special, consequential or incidental damages. "Typical" parameters which may be provided in SCILLC data sheets and/or specifications can and do vary in different applications and actual performance may vary over time. All operating parameters, including "Typicals" must be validated for each customer application by customer's technical experts. SCILLC does not convey any license under its patent rights nor the rights of others. SCILLC products are not designed, intended, or authorized for use as components in systems intended for surgical implant into the body, or other applications intended to support or sustain life, or for any other application in which the failure of the SCILLC product could create a situation where personal injury or death may occur. Should Buyer purchase or use SCILLC products for any such unintended or unauthorized application, Buyer shall indemnify and hold SCILLC and its officers, employees, subsidiaries, affiliates, and distributors harmless against all claims, costs, damages, and expenses, and reasonable attorney fees arising out of, directly or indirectly, any claim of personal injury or death associated with such unintended or unauthorized use, even if such claim alleges that SCILLC was negligent regarding the design or manufacture of the part. SCILLC is an Equal Opportunity/Affirmative Action Employer. This literature is subject to all applicable copyright laws and is not for resale in any manner.

PUBLI CATI ON ORDERI NG I NFORMATI ON

LITERATURE FULFILLMENT:

Literature Distribution Center for ON Semiconductor
 P.O. Box 5163, Denver, Colorado 80217 USA
Phone: 303-675-2175 or 800-344-3860 Toll Free USA/Canada
Fax: 303-675-2176 or 800-344-3867 Toll Free USA/Canada
Email: orderlit@onsemi.com

N American Technical Support: 800-282-9855
 Toll Free USA/Canada
Europe, Middle East and Africa Technical Support:
 Phone: 421 33 790 2910
Japan Customer Focus Center
 Phone: 81-3-5773-3850

ON Semiconductor Website: www.onsemi.com

Order Literature: <http://www.onsemi.com/orderlit>

For additional information, please contact your local Sales Representative