

## MCC-AM335X-Y CPU Module Overview

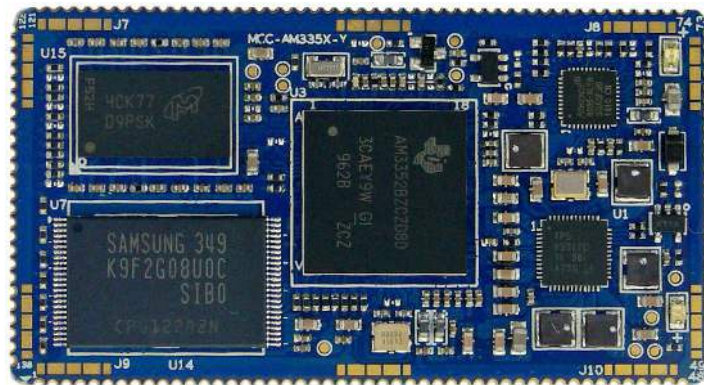

- ✓ Up to 1GHz TI AM335x Series ARM Cortex-A8 Processors
- ✓ 256MB DDR3 SDRAM (128MB/512MB for options)
- ✓ 256MB Nand Flash (128MB/512MB for options)
- ✓ On-board Gigabit Ethernet PHY
- ✓ Power Management IC (PMIC)
- ✓ 1.27mm pitch 146-pin Stamp Hole Expansion Interface
- ✓ Ready-to-Run Linux 4.1.18 OS
- ✓ Supports -40 to +85 Celsius Extended Temperature Operation for Industrial Applications



Measuring only 65mm by 35mm, the MCC-AM335X-Y CPU Module is a ready-to-run Linux Computer on Module (COM) for TI AM335x (AM3352, AM3354, AM3356, AM3357, AM3358 and AM3359) series ARM Cortex-A8 Sitara processors which is a high-performance MPU capable of running at up to 1GHz. The MCC-AM335X-Y CPU module can be used for various industrial embedded applications and supports -40 to +85 Celsius extended temperature operation in harsh working environment.

The MCC-AM335X-Y CPU Module integrates all the core components and is well designed to be the heart of your embedded system. It has the AM335x processor, 256MB DDR3 SDRAM, 256MB Nand Flash, 32Kb EEPROM, Gigabit Ethernet PHY chip on board and features excellent power management circuit design using TI's TPS65217C solution. The module can be soldered to a specific-designed base board through its 1.27mm pitch 146-pin stamp hole expansion interface to meet customers' peripherals, I/O and dimensional requirement.

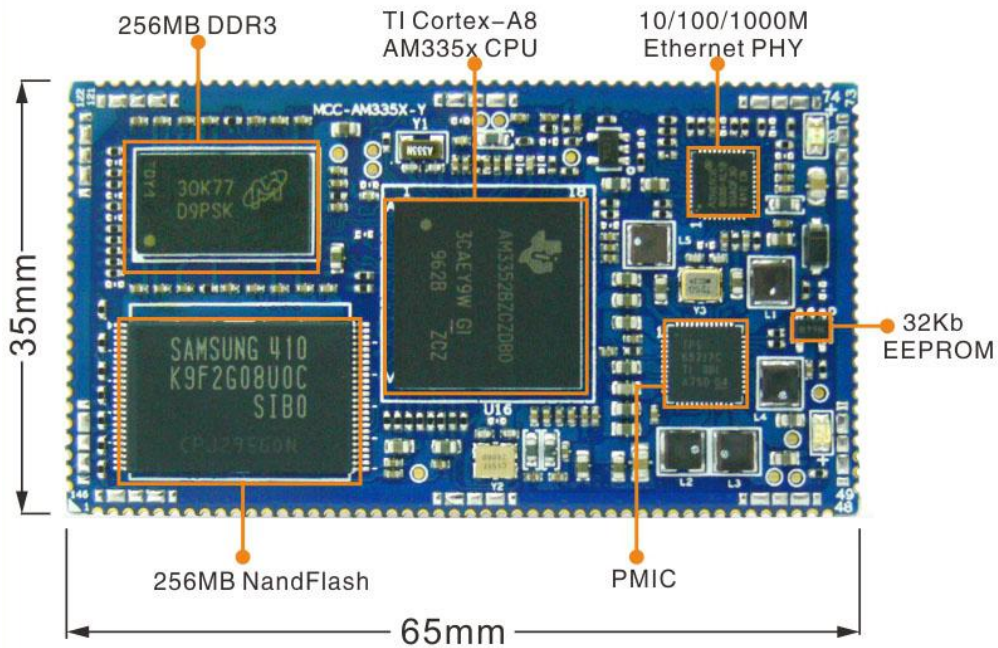

*MCC-AM335X-Y CPU Module*

The TI AM335x consists of 6 different devices with various options including speed grades, packages, graphics and peripherals. The image below gives a brief overview of options. The MCC-AM335X-Y CPU Module series have six models with different AM335x processors.

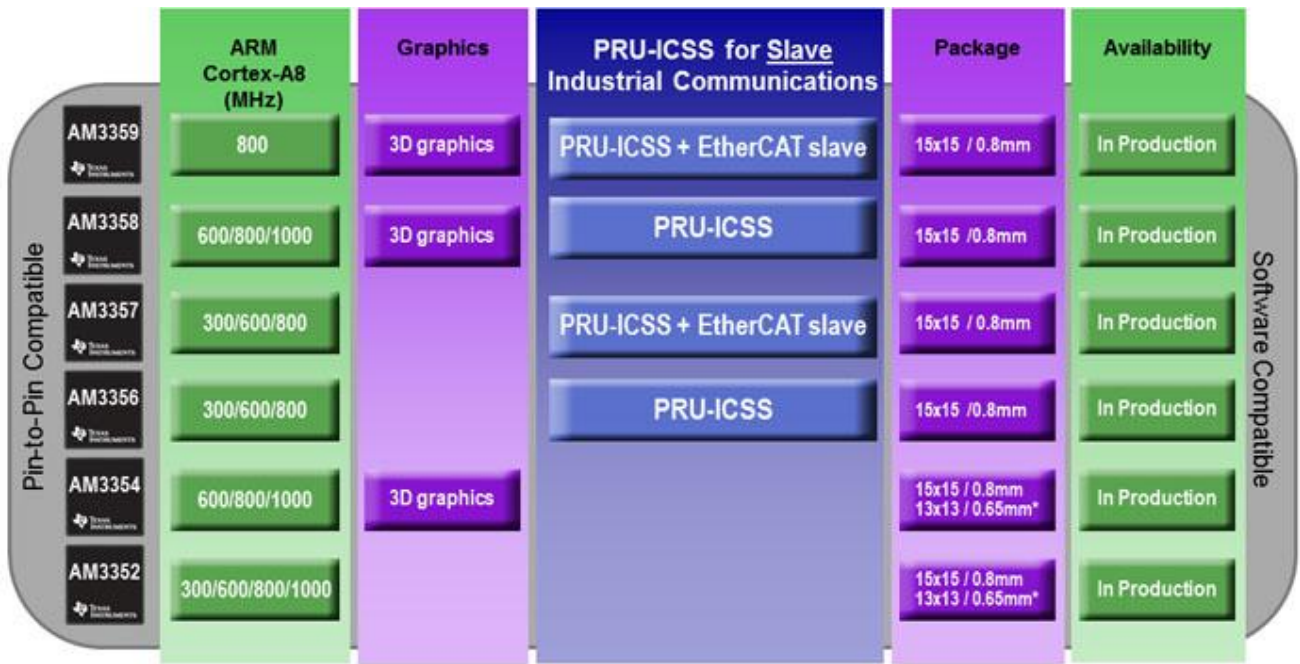

✓ PRU-ICSS is used for slave industrial communication protocols such as Profibus, Profinet, Powerlink & Ethernet/IP

Package	15x15mm (ZCZ)
ARM speed	Up to 1000 MHz
USB 2.0 OTG + PHY	x2
EMAC	2-port switch

AM335x Devices Comparison

MYIR offers a development board MYD-AM335X-Y for rapid evaluation of the MCC-AM335X-Y CPU module. It uses the MCC-AM335X-Y CPU module as controller board and has extended many peripheral interfaces like serial ports, USB Host port, OTG port, dual Gigabit Ethernet ports, WiFi, CAN, RS485, Micro SD and LCD through headers and connectors on the base board. The board is delivered along with some necessary cable accessories and product disk to let you quickly start your development when getting the goods out-of-the-box.

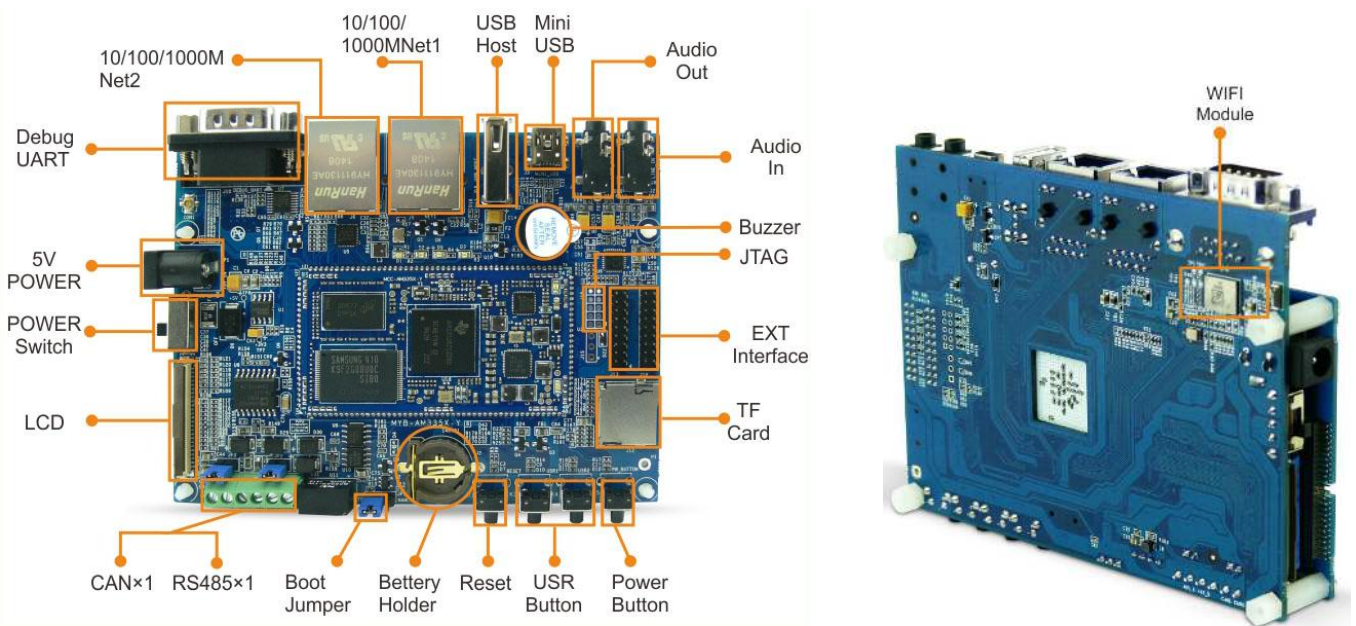

MYD-AM335X-Y Development Board



## Hardware Specification

The [TI AM335x](#) microprocessors, based on the ARM Cortex-A8, operating at up to 1GHz, are enhanced with image, graphics processing, peripherals and industrial interface options such as EtherCAT and PROFIBUS. The device supports the following high-level operating systems (HLOSs) that are available free of charge from TI:

- Linux®
- Android™

The AM335x microprocessor contains these subsystems:

- Microprocessor unit (MPU) subsystem based on the ARM Cortex-A8 microprocessor.
- POWERVR SGX™ Graphics Accelerator subsystem for 3D graphics acceleration to support display and gaming effects.
- The Programmable Real-Time Unit and Industrial Communication Subsystem (PRU-ICSS) is separate from the ARM core, allowing independent operation and clocking for greater efficiency and flexibility. The PRU-ICSS enables additional peripheral interfaces and real-time protocols such as EtherCAT, PROFINET, EtherNet/IP, PROFIBUS, Ethernet Powerlink, Sercos, and others.

AM335x ARM Cortex™-A8 Processors						
Core Feature	<a href="#">AM3352</a>	<a href="#">AM3354</a>	<a href="#">AM3356</a>	<a href="#">AM3357</a>	<a href="#">AM3358</a>	<a href="#">AM3359</a>
Package	15x15mm, 0.8mm (ZCZ)					
CPU Speed (MHz)	300, 600, 800, 1000	600, 800, 1000	300, 600, 800	300, 600, 800	600, 800, 1000	800
Core Internal Memory	64KB SRAM shared w/ Data 32KB Cache, Programmable 32KB Cache					
On-chip L2 (KB)	256					
External Memory Interface	DDR2/DDR3/DDR3L/mDDR (LPDDR), 2x16-bit, NAND ECC					
Graphics	-	3D Graphics	-	-	3D Graphics	
OS Support	Linux, Android, RTOS, Windows Embedded, no-OS					
Other Hardware Acceleration	Crypto Accelerator	Crypto Accelerator	2 PRU-ICSS Crypto Accelerator	2 PRU-ICSS Crypto Accelerator + EtherCAT slave support	2 PRU-ICSS Crypto Accelerator	2 PRU-ICSS Crypto Accelerator + EtherCAT slave support
10/100/1000 EMAC	2 port switch					
USB 2.0 OTG + PHY	2					
Serial Ports	6 UART, 2 SPI, 3 I2C, 2 McASP, 2 CAN, 8 Timers					
System	EDMA, WDT, RTC, 3 eQEP, 3 eCAP, JTAG, ADC (8ch)					
Parallel	3 MMC/SD/SDIO, GPIO					

*AM335x Devices Key Features*

**Mechanical Parameters**

- Dimensions: 65mm x 35mm
- PCB Layers: 10-layer design
- Power supply: +5V/0.8A
- Working temperature: 0~70 Celsius (commercial grade) or -40~85 Celsius (industrial grade)

**Processor**

- TI AM3352, AM3354, AM3356, AM3357, AM3358, AM3359 (15x15 mm, 0.8-mm ball pitch, ZCZ package )
  - 800MHz ARM Cortex-A8 32-bit RISC MPU (Up to 1GHz)
  - NEON™ SIMD Coprocessor
  - 32KB/32KB of L1 Instruction/Data Cache with Single-Error Detection (parity)
  - 256KB of L2 Cache with Error Correcting Code (ECC)
  - SGX530 Graphics Engine
  - Programmable Real-Time Unit Subsystem

**Memory**

- 256MB DDR3 SDRAM (128MB/256MB for options)
- 256MB Nand Flash (128MB/256MB for options)
- 32Kb EEPROM

**Peripherals and Signals Routed to Pins**

- On-board Gigabit Ethernet PHY
- External Watchdog circuit
- Power Management IC (TPS65217C)
- One power indicator (Red LED)
- One user LED (Green)
- 1.27mm pitch 146-pin stamp hole interface can carry out peripherals below:
  - 2 x Gigabit Ethernet
  - 2 x USB2.0 OTG
  - Up to 6 x Serial ports
  - 1 x CAN
  - 2 x I2C
  - 1 x SPI
  - 8 x ADC
  - 2 x PWM
  - 2 x SDIO



**MCC-AM335X-Y Function Block Diagram**

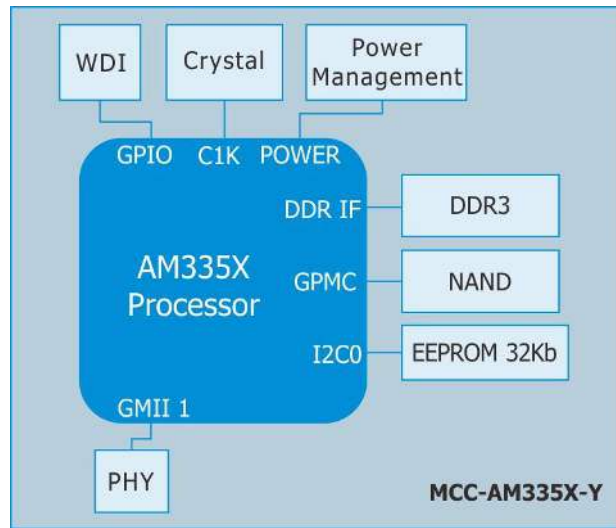

*Function Block Diagram of MCC-AM335X-Y*

**Dimension Chart**

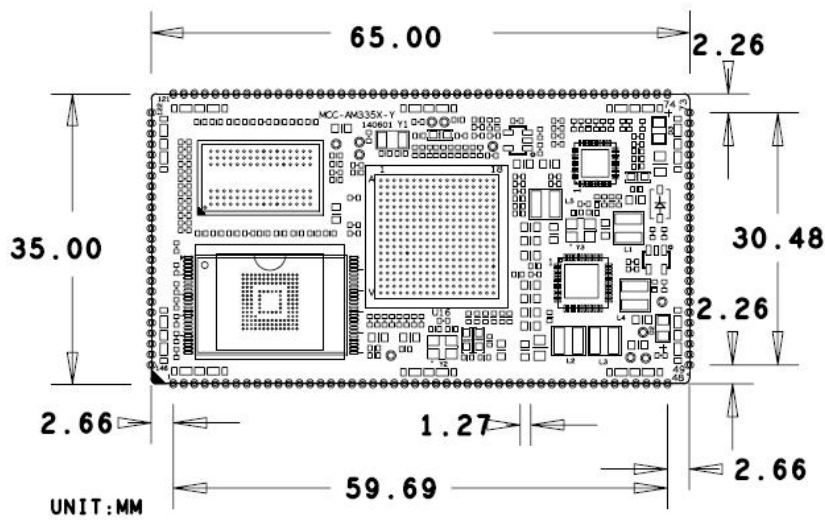

*Dimensions of MCC-AM335X-Y CPU Module*



### Signals Routed to Expansion Connectors

The MCC-AM335X-Y CPU Module has 1.27mm pitch 146-pin stamp hole interface to allow extension of all the controller signals and ports to the base board through headers and connectors, thus exposing more features of the AM335x Cortex-A8 processor. Please refer to below table to know signals routed to the pins:

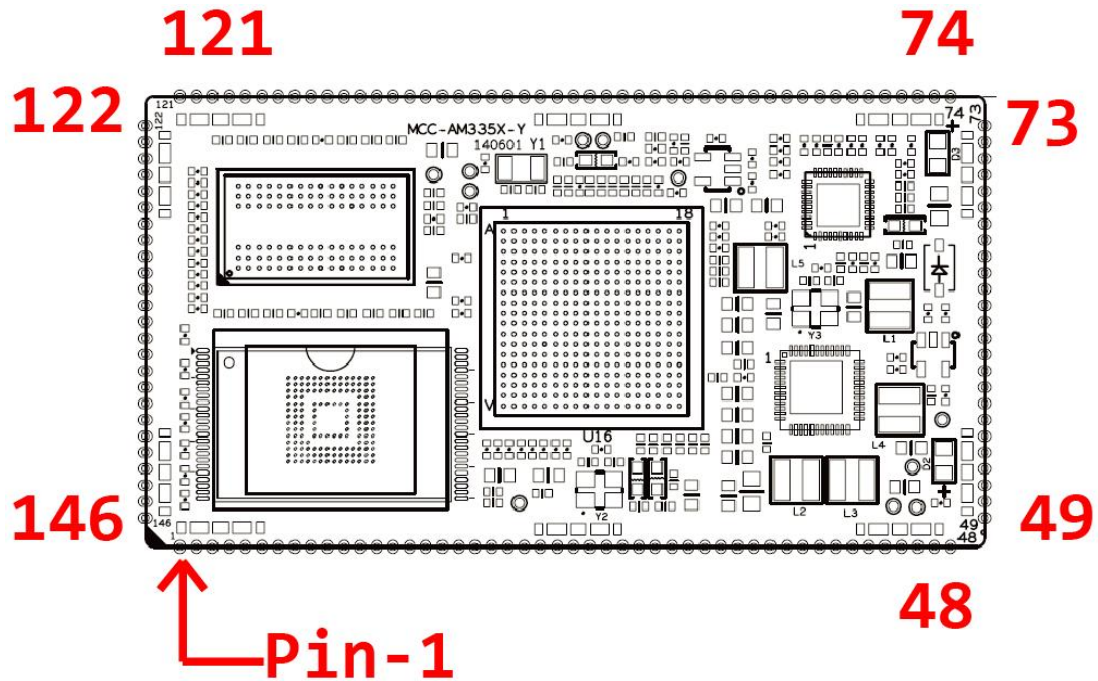

Pin Map of MCC-AM335X-Y

No.	Function	GPIO	Type	Description
1	GND		GND	Ground
2	MMC2_CLK	gpio1_30	0	WiFi SDIO clock, gpio1_30
3	MMC2_CMD	gpio2_0	0	WiFi SDIO command, gpio2_0
4	MMC2_RST	gpio0_22	0	WiFi SDIO reset, gpio0_22
5	MMC2_IRQ	gpio0_23	0	WiFi SDIO Interrupt Request, gpio0_23
6	PWM_REQ	gpio0_26	0	PWM_REQ, gpio0_26
7	SMPS_REQ	gpio0_27	0	WiFi SDIO Spatial Multiplexing Power Save Request, gpio0_27
8	MMC2_DAT0	gpio1_12	I/O	WiFi SDIO data 0, gpio1_12
9	MMC2_DAT1	gpio1_13	I/O	WiFi SDIO data 1, gpio1_13
10	MMC2_DAT2	gpio1_14	I/O	WiFi SDIO data 2, gpio1_14
11	MMC2_DAT3	gpio1_15	I/O	WiFi SDIO data 3, gpio1_15
12	GND		G	Ground
13	MDIO_CLK	gpio0_1	0	MDIO Clk, gpio0_1
14	MDIO_DATA	gpio0_0	I/O	MDIO Data, gpio0_0
15	GMI2_TXEN	gpio1_16	0	GMI2 Transmit Enable, gpio1_16
16	GMI2_RXDV	gpio1_17	0	GMI2 Receive Data Valid, gpio1_17
17	GMI2_TXD3	gpio1_18	0	GMI2 Transmit Data bit 3, gpio1_18
18	GMI2_TXD2	gpio1_19	0	GMI2 Transmit Data bit 2, gpio1_19
19	GMI2_TXD1	gpio1_20	0	GMI2 Transmit Data bit 1, gpio1_20
20	GMI2_TXD0	gpio1_21	0	GMI2 Transmit Data bit 0, gpio1_21
21	GMI2_TXCLK	gpio1_22	I	GMI2 Transmit Clock, gpio1_22



No.	Function	GPIO	Type	Description
22	GMI2_RXCLK	gpio1_23	I	GMI2 Receive Clock, gpio1_23
23	GMI2_RXD3	gpio1_24	I	GMI2 Receive Data bit 3, gpio1_24
24	GMI2_RXD2	gpio1_25	I	GMI2 Receive Data bit 2, gpio1_25
25	GMI2_RXD1	gpio1_26	I	GMI2 Receive Data bit 1, gpio1_26
26	GMI2_RXD0	gpio1_27	I	GMI2 Receive Data bit 0, gpio1_27
27	USB0_DRV	gpio0_18	O	USB0 Active high VBUS control output, gpio0_18
28	USB0_VBUS		A	USB0 VBUS detection input
29	USB0_CE		A	no connect
30	USB0_ID		A	USB0 OTG ID (Micro-A or Micro-B Plug)
31	GND		GND	Ground
32	USB0_DP		DIFF	USB0 Data plus
33	USB0_DM		DIFF	USB0 Data minus
34	GND		GND	Ground
35	USB1_DP		DIFF	USB1 Data plus
36	USB1_DM		DIFF	USB1 Data minus
37	GND		GND	Ground
38	USB1_ID		A	USB0 ID
39	USB1_DRV	gpio3_13	O	USB1 Active high VBUS control output, gpio3_13
40	USB1_VBUS		A	USB1 VBUS detection input
41	RESETN		I	Active low Power on Reset
42	RTC_RST		I	Active low RTC reset input
43	WDT		I	Manual Reset input
44	PWR_BUT		I	PMIC bottom input
45	VDD_5V		PWR	5V Supply input
46	VDD_5V		PWR	5V Supply input
47	GND		GND	Ground
48	VDD_3.3VB		PWR	3.3V IO Level output
49	VDD18_RTC		PWR	RTC Battery
50	GND		GND	Ground
51	MMC0_CLK	gpio2_30	O	MMC0 clock, gpio2_30
52	MMC0_CMD	gpio2_31	O	MMC0 command, gpio2_31
53	MMC0_DAT0	gpio2_29	IO	MMC0 data 0, gpio2_29
54	MMC0_DAT1	gpio2_28	IO	MMC0 data 1, gpio2_28d
55	MMC0_DAT2	gpio2_27	IO	MMC0 data 2, gpio2_27
56	MMC0_DAT3	gpio2_26	IO	MMC0 data 3, gpio2_26
57	MCASP0_AHCLKX	gpio3_21	O	McASP/I2S MCLK, gpio3_21
58	I2C0_SCL	gpio3_6	O	I2C0 clock (open drain with pull-up resistor on the SOM), gpio3_6
59	I2C0_SDA	gpio3_5	IO	I2C0 data (open drain with pull-up resistor on the SOM), gpio3_5
60	LEDA		I	WLED driver, no connect
61	LEDK1		I	WLED driver, no connect
62	LEDK2		I	WLED driver, no connect
63	GND		GND	Ground
64	RGMII1_TRP0		DIFF	Ethernet Data 0 Positive
65	RGMII1_TRN0		DIFF	Ethernet Data 0 Negative





No.	Function	GPIO	Type	Description
66	RGMII1_TRP1		DIFF	Ethernet Data 1 Positive
67	RGMII1_TRN1		DIFF	Ethernet Data 1 Negative
68	GND		GND	Ground
69	RGMII1_TRP2		DIFF	Ethernet Data 2 Positive
70	RGMII1_TRN2		DIFF	Ethernet Data 2 Negative
71	RGMII1_TRP3		DIFF	Ethernet Data 3 Positive
72	RGMII1_TRN3		DIFF	Ethernet Data 3 Negative
73	GND		GND	Ground
74	RGMII1_LINK		O	PHY 1000M Link LED
75	RGMII1_ACT		O	PHY Status LED
76	RGMII1_OPT		O	PHY 100M Link LED
77	GND		GND	Ground
78	DCAN0_TX	gpio0_12 J13-8	O	User LED1, gpio0_12
79	DCAN0_RX	gpio0_13 J13-6	O	User LED2, gpio0_13
80	UART0_TX	gpio1_11,J10	O	Dbg Uart TX, gpio1_11
81	UART0_RX	gpio1_10,J10	I	Dbg Uart RX, gpio1_10
82	UART1_TX	gpio0_15	O	Uart 1 TX, gpio0_15
83	UART1_RX	gpio0_14,J13-7	I	Uart 1 RX, gpio0_14
84	UART2_TX	gpio3_2 CON2	O	Uart 2 TX, use for RS485, gpio3_2
85	UART2_RX	gpio3_1 CON2	I	Uart 2 RX, use for RS485, gpio3_1
86	GND		GND	Ground
87	UART3_TX	gpio0_7	O	Buzzer, gpio0_7
88	UART3_RX	gpio0_6	I	Touch INT, gpio0_6
89	UART4_TX	gpio1_9	O	Uart 4 TX, use for CAN, gpio1_9
90	UART4_RX	gpio1_8	I	Uart 4 RX, use for CAN, gpio1_8
91	UART5_TX	gpio0_29	I	User KEY2, gpio0_29
92	UART5_RX	gpio3_0	I	User KEY1, gpio3_0
93	GND		GND	Ground
94	JTAG_TRSTn		O	JTAG TEST RESET (ACTIVE LOW)
95	JTAG_TMS		O	JTAG TEST MODE SELECT
96	JTAG_TDI		I	JTAG TEST DATA INPUT
97	JTAG_TCK		I	JTAG TEST CLOCK
98	JTAG_TDO		O	JTAG TEST DATA OUTPUT
99	VDD_ADC		PWR	Supply voltage range for ADC
100	AIN0		A	Analog Input/Output 0, used with touchscreen
101	AIN1		A	Analog Input/Output 1, used with touchscreen
102	AIN2		A	Analog Input/Output 2, used with touchscreen
103	AIN3		A	Analog Input/Output 3, used with touchscreen
104	AIN4		A	Analog Input/Output 4, used with touchscreen
105	AIN5		A	Analog Input/Output 5
106	AIN6		A	Analog Input/Output 6
107	AIN7		A	Analog Input/Output 7



No.	Function	GPIO	Type	Description
108	GND		GND	Ground
109	EVENT_INTR0	gpio0_19	O	LCD Enable, gpio0_19
110	EVENT_INTR1	gpio0_20	I	NET1 INIT, gpio0_19
111	GND		GND	Ground
112	I2C1_SCL	gpio0_5	O	I2C1_SCL, gpio0_5
113	I2C1_SDA	gpio0_4	IO	I2C1 Data, gpio0_4
114	PWM1	gpio0_2	O	LCD Bright, gpio0_2
115	PWM2	gpio0_3	O	LED, gpio0_3
116	GND		GND	Ground
117	MCASP0_ACLKX	gpio3_14	O	McASP0/ I2S Transmit Bit Clock, gpio3_14
118	MCASP0_FSX	gpio3_15	O	McASP0 Transmit Frame Sync, gpio3_14
119	GPIO3_16	gpio3_16	O	gpio3_16 use for Touchscreen reset
120	MCASP0_AHCLKR	gpio3_17	IO	McASP0 Receive Master Clock, gpio3_17
121	USER_LED1	gpio3_18	O	SOM LED, gpio3_18
122	GPIO3_19	gpio3_19	I	gpio MMC0 detection, gpio3_19
123	MCASP0_AXR1	gpio3_20	IO	McASP0 Serial Data (IN/OUT), gpio3_20
124	LCD_DATA0	gpio2_6	IO	LCD Data line 0, gpio2_6
125	LCD_DATA1	gpio2_7	IO	LCD Data line 1, gpio2_7
126	LCD_DATA2	gpio2_8	IO	LCD Data line 2, gpio2_8
127	LCD_DATA3	gpio2_9	IO	LCD Data line 3 / boot config / gpio2_9
128	LCD_DATA4	gpio2_10	IO	LCD Data line 4, gpio2_10
129	LCD_DATA5	gpio2_11	IO	LCD Data line 5, gpio2_11
130	LCD_DATA6	gpio2_12	IO	LCD Data line 6, gpio2_12
131	LCD_DATA7	gpio2_13	IO	LCD Data line 7, gpio2_13
132	GND		GND	Ground
133	LCD_DATA8	gpio2_14	IO	LCD Data line 8, gpio2_14
134	LCD_DATA9	gpio2_15	IO	LCD Data line 9, gpio2_15
135	LCD_DATA10	gpio2_16	IO	LCD Data line 10, gpio2_16
136	LCD_DATA11	gpio2_17	IO	LCD Data line 11, gpio2_17
137	LCD_DATA12	gpio0_8	IO	LCD Data line 12, gpio0_8
138	LCD_DATA13	gpio0_9	IO	LCD Data line 13, gpio0_9
139	LCD_DATA14	gpio0_10	IO	LCD Data line 14, gpio0_10
140	LCD_DATA15	gpio0_11	IO	LCD Data line 15, gpio0_11
141	GND		GND	Ground
142	LCDPCLK	gpio2_24	O	LCD peix clock, gpio2_24
143	LCDVSYNC	gpio2_22	O	LCD vertical Synchronization signal, gpio2_22
144	LCDVHYNC	gpio2_23	O	LCD horizontal Synchronization signal, gpio2_23
145	LCDDE	gpio2_25	O	LCD Data Enable, gpio2_25
146	GND			Ground

*Pin Outs of MCC-AM335X-Y*



## Software Features

MYIR's MCC-AM335X-Y CPU module is preloaded with Linux 4.1.18 operating system. Many peripheral drivers are in source code to help accelerate customers' designs with a stable and reliable hardware and software platform. The software features are summarized as below:

Item	Features	Description
<b>Bootstrap</b>	SPL	The primary bootstrap (in source code)
	u-boot	The secondary bootstrap (in source code)
<b>Linux kernel</b>	Linux 4.1.18	Linux kernel customized for MYD-AM335X-Y (in source code)
<b>Drivers</b>	USB	USB Host/Device/OTG driver (in source code)
	Ethernet	Gigabit Ethernet driver (in source code)
	MMC/SD/TF	MMC/SD/TF card driver (in source code)
	NandFlash	NandFlash driver (in source code)
	CAN	CAN driver (in source code)
	RS485	RS485 driver (in source code)
	Audio	Audio driver (in source code)
	LCD Controller	LCD driver, support 4.3-inch and 7-inch TFT LCD (in source code)
	RTC	RTC driver (in source code)
	Touch driver	Resistive Touch driver (in source code)
		Capacitive Touch driver (in source code)
	Botton	Botton driver (in source code)
	UART	UART driver (in source code)
	LED	LED driver (in source code)
	GPIO	GPIO driver (in source code)
WatchDog	Watchdog driver (in source code)	
<b>File System</b>	Buildroot	Provide tar package and ubi image file

### *MCC-AM335X-Y Software Features*



**Order Information**

<b>Product Item</b>	<b>Part No.</b>
MCC-AM335X-Y CPU Module	MYC-Y3352-V2-256N256D-80-I
	MYC-Y3358-V2-256N256D-100-I
MYD-AM335X-Y Development Board	MYD-Y3352-V2-256N256D-80-I
	MYD-Y3358-V2-256N256D-100-I
MY-LCD43TP 4.3-inch LCD Module with resistive touch screen	MY-TFT043RV2
MY-LCD70TP 7-inch LCD Module with resistive touch screen	MY-TFT070RV2
MY-LCD70TP-C 7-inch LCD Module with capacitive touch screen	MY-TFT070CV2
<p>Note:</p> <ol style="list-style-type: none"> <li>1. Please specify the CPU model you prefer with the MCC-AM335X-Y module, we deliver 800MHz AM3352 or 1GHz AM3358 by default, and can also supply other models for bulk orders.</li> <li>2. For Price information, please contact MYIR.</li> <li>3. The MCC-AM335X-Y CPU Module has commercial grade version can work from 0 to 70 Celsius and industrial grade version can work from -40 to 85 Celsius.</li> <li>4. We accept custom design based on the MCC-AM335X-Y, whether reducing, adding or modifying the existing hardware according to customer' s requirement.</li> </ol>	



**MYIR Tech Limited**

Headquarter Address: Room 04, 6th Floor, Building No.2, Fada Road, Yunli Smart Park, Bantian, Longgang District, Shenzhen, Guangdong, China 518129

Factory Address: Room 201, Block C, Shengjianli Industrial Park, Dafu Industrial Zone, Guanlan, Longhua District, Shenzhen, 518110, China

Website: [www.myirtech.com](http://www.myirtech.com)

Email: [sales@myirtech.com](mailto:sales@myirtech.com)

Tel: +86-755-22984836