

PROPRIETARY INFORMATION  
NOT TO BE RELEASED  
WITHOUT WRITTEN PERMISSION  
FROM AN AUTHORIZED  
REPRESENTATIVE OF  
APPLIED ENGINEERING PRODUCTS

REVISIONS			
REV	DESCRIPTION	DATE	APPROVED
-	INITIAL RELEASE	10/14/98	E.W.

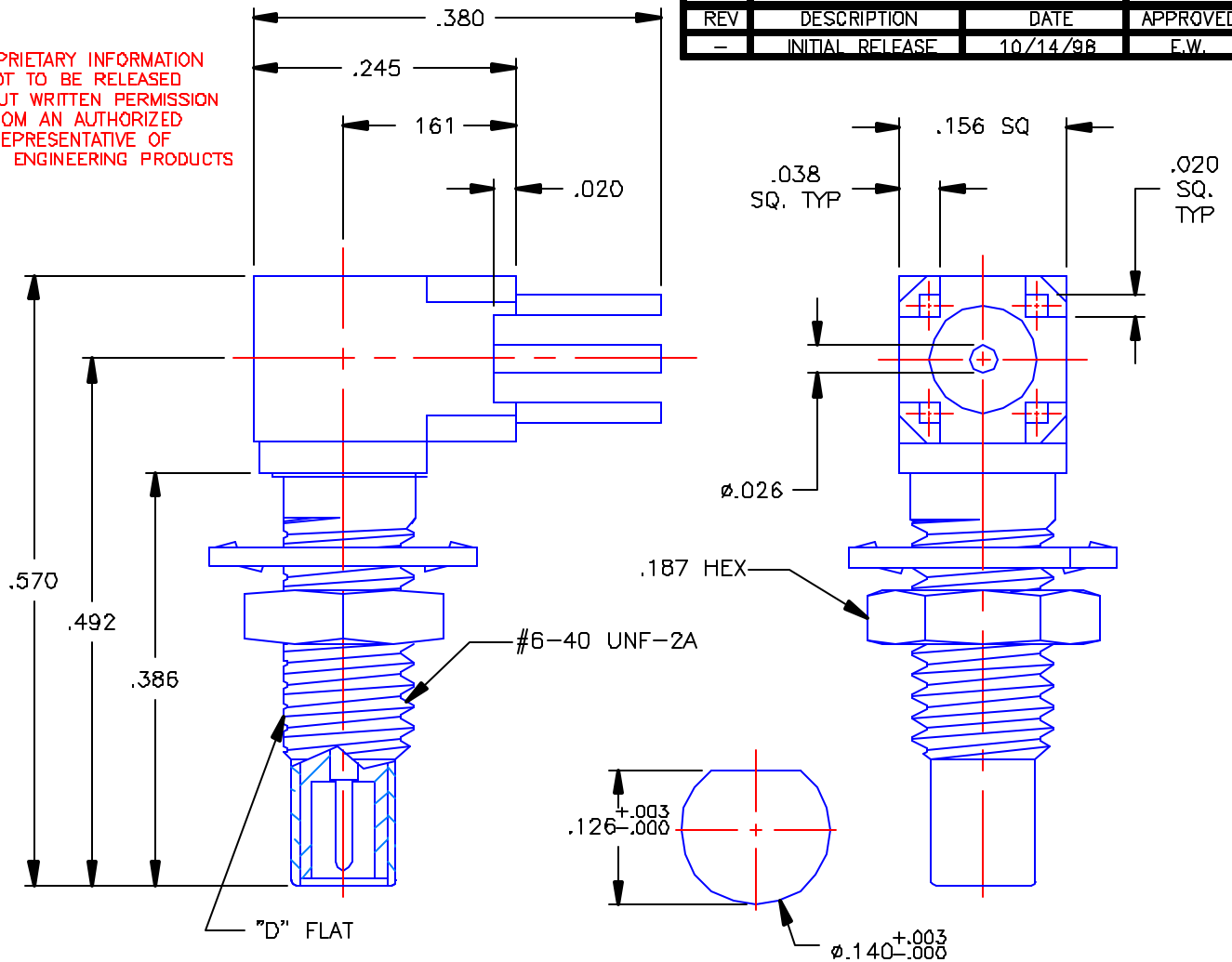

RECOMMENDED MOUNTING HOLE

**NOTES:**

**MATERIAL:**

1. BODIES, LOCKNUT & CAP = BRASS PER ASTM B16, ALLOY C36000, TEMPER H02.
2. CONTACTS = BERYLLIUM COPPER PER ASTM B196, ALLOY C17300, TEMPER TD04.
3. INSULATORS =TEFLON VIRGIN WHITE, ASTM D1710, GRADE 1, TYPE I, CLASS "A".
4. LOCKWASHER = PHOSPHOR BRONZE PER ASTM B139, COPPER ALLOY C53400, TEMPER H04.

**FINISHES:**

1. BODIES, LOCKNUT, LOCKWASHER & CAP = GOLD PLATE PER MIL-G-45204, TYPE II, CLASS 0, GRADE C, OVER .00010 TO .00020 COPPER STRIKE PER MIL-C-14550.
2. CONTACTS = GOLD PLATE PER MIL-G-45204, TYPE II, CLASS 1, GRADE C, OVER .00010 TO .00020 STRESS FREE SULFAMATE NICKEL PER QQ-N-290.

UNLESS OTHERWISE SPECIFIED  
DIMENSIONS ARE IN INCHES  
TOLERANCES ON

DWN: DATE  
E.W. 10/14/98



APPLIED ENGINEERING PRODUCTS

104 John W. Murphy Dr.  
New Haven, CT 06513

CHKD: DATE  
T.P.S. 10/14/98

APVD: DATE  
G.T. 10/19/98

SSMC RIGHT ANGLE  
BULKHEAD MOUNT P.C.B. JACK  
WITH STANDOFFS

DECIMAL	FRAC	ANGLE
	1/64	±2°

MATERIAL:  
SEE NOTES

FINISH:  
SEE NOTES

SIZE	FSCM NO.	DWG NO.	REV
A	19505	7110-1511-050	-
SCALE 6:1		CADFILE 7110-1511-050	SHEET 1 OF 1