

LOC	DIST	REVISIONS			
		REV	DESCRIPTION	DATE	BY
AJ	16	BL1	REVISED PER ECO-11-005030	11MAR11	RK HMR

1. SEE IS 1770
2. BRASS PER QQ-B-626
3. NYLON PER ASTM-D-4066, NATURAL.
4. POLYMETHYLPENTENE GENERAL PURPOSE.
5. .000030 MINIMUM GOLD PER MIL-G-45204.
6. .000100 MINIMUM GOLD PER MIL-G-45204.

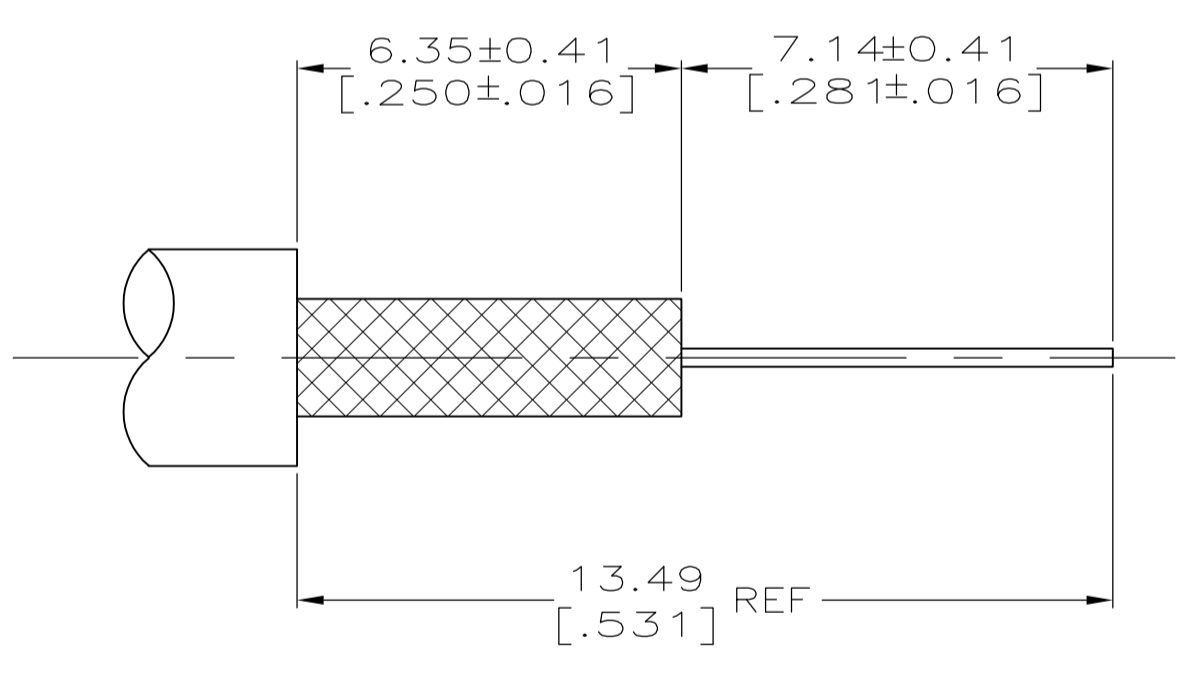
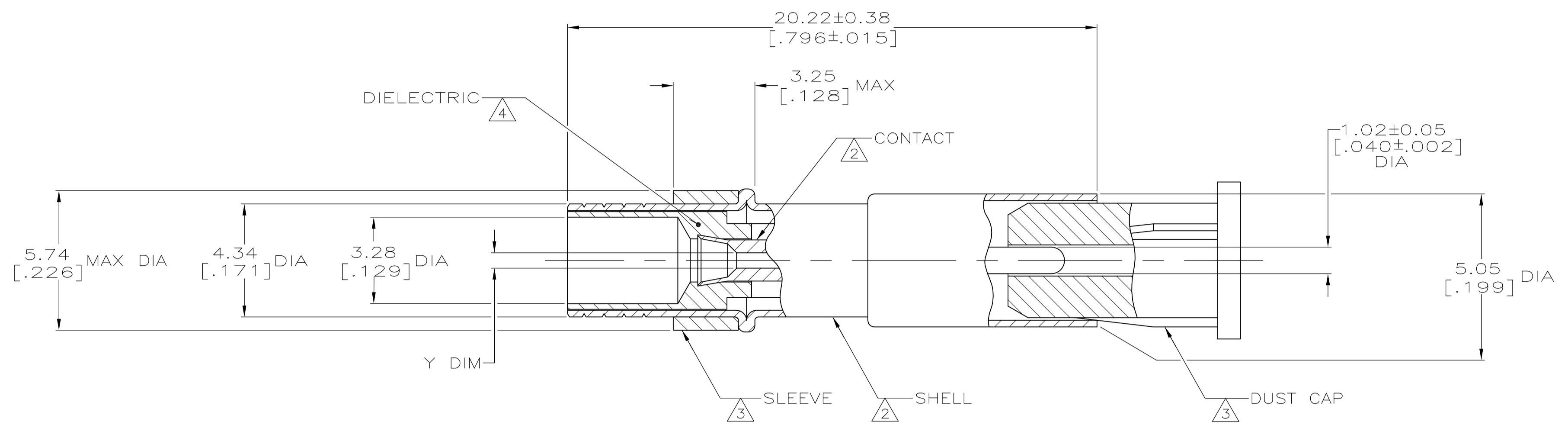

RECOMMENDED STRIP LENGTH

REV	DESCRIPTION	DATE	BY
6	OBsolete		
5			
4			
3			
2			
1			

CONTACT PLATING	SHELL PLATING	"Y" DIM	PART NUMBER
5	6	.042±.003	1-201146-0
6	6	.042±.003	201146-9
5	5	.023±.003	201146-6
5	5	.042±.003	201146-4
5	5	.023±.003	201146-2
5	5	.042±.003	201146-1

THIS DRAWING IS A CONTROLLED DOCUMENT.

DIN	WERNER	8-9-94
CHK	J. McLEOD	8-9-94
APVD	J. McLEOD	8-9-94

**STE** TE Connectivity

NAME: SOCKET, MINIATURE SERIES

SIZE	CAGE CODE	DRAWING NO	RESTRICTED TO
A1	00779	201146	

CUSTOMER DRAWING SCALE: 8:1 SHEET 1 OF 1 REV BL1