

# QUAD FREQUENCY CRYSTAL OSCILLATOR (XO) (10 MHz TO 1.4 GHz)

## Features

- Available with any-rate output frequencies from 10 MHz to 945 MHz and select frequencies to 1.4 GHz
- Four selectable output frequencies
- 3rd generation DSPLL® with superior jitter performance
- 3x better frequency stability than SAW-based oscillators
- Internal fixed crystal frequency ensures high reliability and low aging
- Available CMOS, LVPECL, LVDS, and CML outputs
- 3.3, 2.5, and 1.8 V supply options
- Industry-standard 5 x 7 mm package and pinout
- Pb-free/RoHS-compliant

## Applications

- SONET/SDH
- Networking
- SD/HD video
- Test and measurement
- Clock and data recovery
- FPGA/ASIC clock generation

## Description

The Si534 quad frequency XO utilizes Skyworks Solutions' advanced DSPLL® circuitry to provide a low jitter clock at high frequencies. The Si534 is available with any-rate output frequency from 10 to 945 MHz and select frequencies to 1400 MHz. Unlike a traditional XO where a different crystal is required for each output frequency, the Si534 uses one fixed crystal to provide a wide range of output frequencies. This IC-based approach allows the crystal resonator to provide exceptional frequency stability and reliability. In addition, DSPLL clock synthesis provides superior supply noise rejection, simplifying the task of generating low jitter clocks in noisy environments typically found in communication systems. The Si534 IC-based XO is factory configurable for a wide variety of user specifications including frequency, supply voltage, output format, and temperature stability. Specific configurations are factory programmed at time of shipment, thereby eliminating long lead times associated with custom oscillators.

## Functional Block Diagram

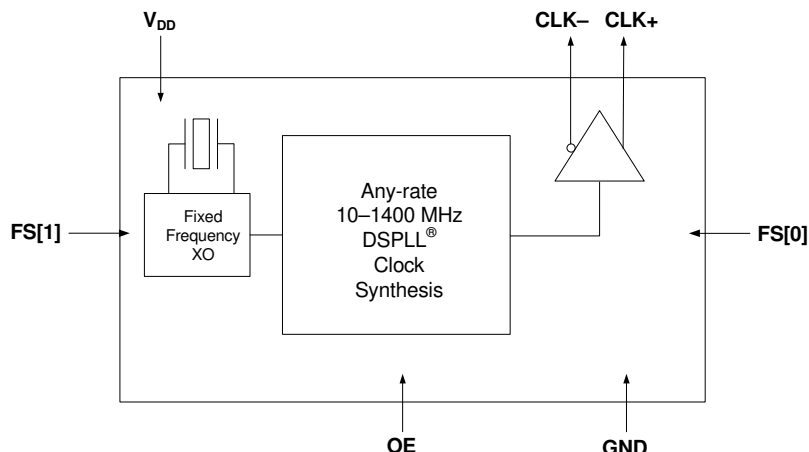

### Ordering Information:

See page 7.

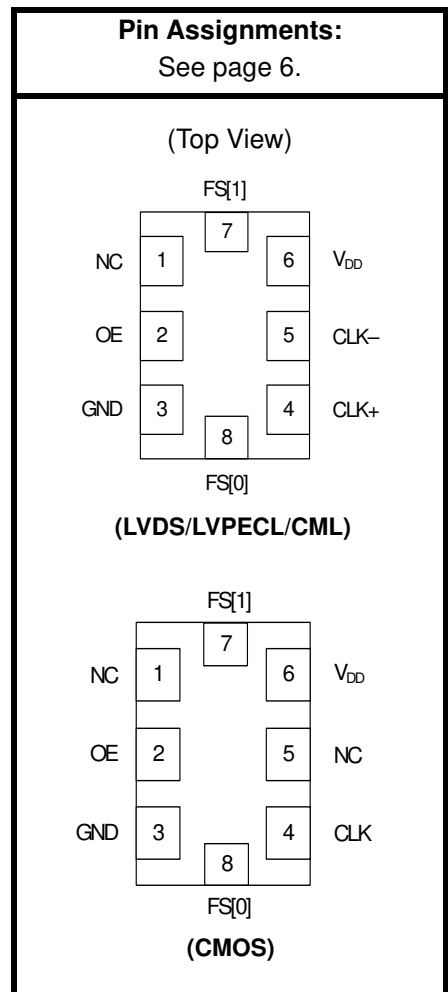

## 1. Electrical Specifications

**Table 1. Recommended Operating Conditions**

Parameter	Symbol	Test Condition	Min	Typ	Max	Units
Supply Voltage <sup>1</sup>	V <sub>DD</sub>	3.3 V option	2.97	3.3	3.63	V
		2.5 V option	2.25	2.5	2.75	V
		1.8 V option	1.71	1.8	1.89	V
Supply Current	I <sub>DD</sub>	Output enabled LVPECL	—	111	121	mA
		CML	—	99	108	
		LVDS	—	90	98	
		CMOS	—	81	88	
		Tristate mode	—	60	75	mA
Output Enable (OE) and Frequency Select FS[1:0] <sup>2</sup>		V <sub>IH</sub>	0.75 x V <sub>DD</sub>	—	—	V
		V <sub>IL</sub>	—	—	0.5	V
Operating Temperature Range	T <sub>A</sub>		−40	—	85	°C

**Notes:**

- Selectable parameter specified by part number. See Section 3. "Ordering Information" on page 7 for further details.
- OE and FS[1:0] pins include a 17 kΩ pullup resistor to V<sub>DD</sub>.

**Table 2. CLK± Output Frequency Characteristics**

Parameter	Symbol	Test Condition	Min	Typ	Max	Units	
Nominal Frequency <sup>1,2</sup>	f <sub>O</sub>	LVPECL/LVDS/CML	10	—	945	MHz	
		CMOS	10	—	160	MHz	
Initial Accuracy	f <sub>i</sub>	Measured at +25 °C at time of shipping	—	±1.5	—	ppm	
Temperature Stability <sup>1,3</sup>			−7	—	+7	ppm	
			−20	—	+20		
			−50	—	+50		
Aging	f <sub>a</sub>	Frequency drift over first year	—	—	±3	ppm	
		Frequency drift over 20-year life	—	—	±10	ppm	
Total Stability			Temp stability = ±7 ppm	—	—	±20	ppm
			Temp stability = ±20 ppm	—	—	±31.5	ppm
			Temp stability = ±50 ppm	—	—	±61.5	ppm

**Notes:**

- See Section 3. "Ordering Information" on page 7 for further details.
- Specified at time of order by part number. Also available in frequencies from 970 to 1134 MHz and 1213 to 1417 MHz.
- Selectable parameter specified by part number.
- Time from powerup or tristate mode to f<sub>O</sub>.

Table 2. CLK± Output Frequency Characteristics (Continued)

Parameter	Symbol	Test Condition	Min	Typ	Max	Units
Powerup Time <sup>4</sup>	$t_{OSC}$		—	—	10	ms
Settling Time After FS[1:0] Change	$t_{FRQ}$	Both FS[1] and FS[0] changing simultaneously	—	—	20	ms

**Notes:**

1. See Section 3. "Ordering Information" on page 7 for further details.
2. Specified at time of order by part number. Also available in frequencies from 970 to 1134 MHz and 1213 to 1417 MHz.
3. Selectable parameter specified by part number.
4. Time from powerup or tristate mode to  $f_O$ .

Table 3. CLK± Output Levels and Symmetry

Parameter	Symbol	Test Condition	Min	Typ	Max	Units
LVPECL Output Option <sup>1</sup>	$V_O$	mid-level	$V_{DD} - 1.42$	—	$V_{DD} - 1.25$	V
	$V_{OD}$	swing (diff)	1.1	—	1.9	$V_{PP}$
	$V_{SE}$	swing (single-ended)	0.55	—	0.95	$V_{PP}$
LVDS Output Option <sup>2</sup>	$V_O$	mid-level	1.125	1.20	1.275	V
	$V_{OD}$	swing (diff)	0.5	0.7	0.9	$V_{PP}$
CML Output Option <sup>2</sup>	$V_O$	2.5/3.3 V option mid-level	—	$V_{DD} - 1.30$	—	V
		1.8 V option mid-level	—	$V_{DD} - 0.36$	—	V
	$V_{OD}$	2.5/3.3 V option swing (diff)	1.10	1.50	1.90	$V_{PP}$
		1.8 V option swing (diff)	0.35	0.425	0.50	$V_{PP}$
CMOS Output Option <sup>3</sup>	$V_{OH}$	$I_{OH} = 32$ mA	$0.8 \times V_{DD}$	—	$V_{DD}$	V
	$V_{OL}$	$I_{OL} = 32$ mA	—	—	0.4	V
Rise/Fall time (20/80%)	$t_R, t_F$	LVPECL/LVDS/CML	—	—	350	ps
		CMOS with $C_L = 15$ pF	—	1	—	ns
Symmetry (duty cycle)	SYM	LVPECL: $V_{DD} - 1.3$ V (diff) LVDS: 1.25 V (diff) CMOS: $V_{DD}/2$	45	—	55	%

**Notes:**

1.  $50 \Omega$  to  $V_{DD} - 2.0$  V.
2.  $R_{term} = 100 \Omega$  (differential).
3.  $C_L = 15$  pF

**Table 4. CLK± Output Phase Jitter**

Parameter	Symbol	Test Condition	Min	Typ	Max	Units
Phase Jitter (RMS) <sup>1</sup> for F <sub>OUT</sub> ≥ 500 MHz	ϕ <sub>J</sub>	12 kHz to 20 MHz (OC-48)	—	0.25	0.40	ps
		50 kHz to 80 MHz (OC-192)	—	0.26	0.37	ps
Phase Jitter (RMS) <sup>1</sup> for F <sub>OUT</sub> of 125 to 500 MHz	ϕ <sub>J</sub>	12 kHz to 20 MHz (OC-48)	—	0.36	0.50	ps
		50 kHz to 80 MHz (OC-192) <sup>2</sup>	—	0.34	0.42	ps
Phase Jitter (RMS) for F <sub>OUT</sub> of 10 to 160 MHz CMOS Output Only	ϕ <sub>J</sub>	12 kHz to 20 MHz (OC-48) <sup>2</sup>	—	0.62	—	ps
		50 kHz to 20 MHz <sup>2</sup>	—	0.61	—	ps

**Notes:**

1. Refer to AN256 for further information.
2. Max offset frequencies: 80 MHz for F<sub>OUT</sub> ≥ 250 MHz, 20 MHz for 50 MHz ≤ F<sub>OUT</sub> < 250 MHz, 2 MHz for 10 MHz ≤ F<sub>OUT</sub> < 50 MHz.

**Table 5. CLK± Output Period Jitter**

Parameter	Symbol	Test Condition	Min	Typ	Max	Units
Period Jitter*	J <sub>PER</sub>	RMS	—	2	—	ps
		Peak-to-Peak	—	14	—	ps

**\*Note:** Any output mode, including CMOS, LVPECL, LVDS, CML. N = 1000 cycles. Refer to AN279 for further information.

**Table 6. CLK± Output Phase Noise (Typical)**

Offset Frequency (f)	120.00 MHz	156.25 MHz	622.08 MHz	Units
	LVDS	LVPECL	LVPECL	
100 Hz	-112	-105	-97	dBc/Hz
1 kHz	-122	-122	-107	
10 kHz	-132	-128	-116	
100 kHz	-137	-135	-121	
1 MHz	-144	-144	-134	
10 MHz	-150	-147	-146	
100 MHz	n/a	n/a	-148	

**Table 7. Environmental Compliance**

The Si534 meets the following qualification test requirements.

Parameter	Conditions/Test Method
Mechanical Shock	MIL-STD-883, Method 2002
Mechanical Vibration	MIL-STD-883, Method 2007
Solderability	MIL-STD-883, Method 2003
Gross & Fine Leak	MIL-STD-883, Method 1014
Resistance to Solder Heat	MIL-STD-883, Method 2036
Moisture Sensitivity Level	J-STD_020, MSL1
Contact Pads	Gold over Nickel

**Table 8. Thermal Characteristics**

(Typical values  $T_A = 25\text{ }^\circ\text{C}$ ,  $V_{DD} = 3.3\text{ V}$ )

Parameter	Symbol	Test Condition	Min	Typ	Max	Unit
Thermal Resistance Junction to Ambient	$\theta_{JA}$	Still Air	—	84.6	—	$^\circ\text{C/W}$
Thermal Resistance Junction to Case	$\theta_{JC}$	Still Air	—	38.8	—	$^\circ\text{C/W}$
Ambient Temperature	$T_A$		-40	—	85	$^\circ\text{C}$
Junction Temperature	$T_J$		—	—	125	$^\circ\text{C}$

**Table 9. Absolute Maximum Ratings<sup>1</sup>**

Parameter	Symbol	Rating	Units
Maximum Operating Temperature	$T_{AMAX}$	85	$^\circ\text{C}$
Supply Voltage, 1.8 V Option	$V_{DD}$	-0.5 to +1.9	V
Supply Voltage, 2.5/3.3 V Option	$V_{DD}$	-0.5 to +3.8	V
Input Voltage (any input pin)	$V_I$	-0.5 to $V_{DD} + 0.3$	V
Storage Temperature	$T_S$	-55 to +125	$^\circ\text{C}$
ESD Sensitivity (HBM, per JEDEC22-A114)	ESD	2000	V
Soldering Temperature (Pb-free profile) <sup>2</sup>	$T_{PEAK}$	260	$^\circ\text{C}$
Soldering Temperature Time @ $T_{PEAK}$ (Pb-free profile) <sup>2</sup>	$t_P$	20–40	seconds

**Notes:**

1. Stresses beyond those listed in Absolute Maximum Ratings may cause permanent damage to the device. Functional operation or specification compliance is not implied at these conditions. Exposure to maximum rating conditions for extended periods may affect device reliability.
2. The device is compliant with JEDEC J-STD-020C. Refer to Si5xx Packaging FAQ available for download at [https://www.skyworksinc.com/Product\\_Certificate.aspx](https://www.skyworksinc.com/Product_Certificate.aspx) for further information, including soldering profiles.

## 2. Pin Descriptions

(Top View)

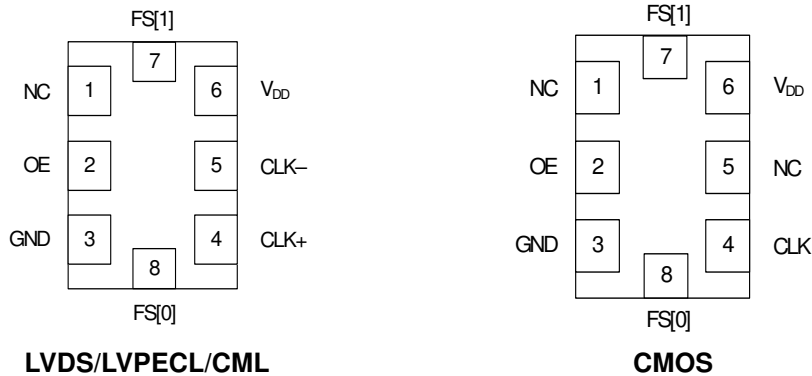

**Table 10. Pin Descriptions**

Pin	Symbol	LVDS/LVPECL/CML Function	CMOS Function
1	NC	No connection	No connection
2	OE*	Output enable 0 = clock output disabled (outputs tristated) 1 = clock output enabled	Output enable 0 = clock output disabled (outputs tristated) 1 = clock output enabled
3	GND	Electrical and Case Ground	Electrical and Case Ground
4	CLK+	Oscillator Output	Oscillator Output
5	CLK-	Complementary Output	No connection
6	V <sub>DD</sub>	Power Supply Voltage	Power Supply Voltage
7	FS[1]*	Frequency Select MSB	Frequency Select MSB
8	FS[0]*	Frequency Select LSB	Frequency Select LSB

**\*Note:** FS[1:0] and OE include a 17 kΩ pullup resistor to V<sub>DD</sub>. See Section 3. "Ordering Information" on page 7 for details on frequency value ordering.

### 3. Ordering Information

The Si534 XO supports a variety of options including frequency, temperature stability, output format, and  $V_{DD}$ . Specific device configurations are programmed into the Si534 at time of shipment. Configurations can be specified using the Part Number Configuration chart below. Skyworks Solutions provides a web browser-based part number configuration utility to simplify this process. Refer to <https://www.skyworksinc.com/en/Products/Timing> to access this tool and for further ordering instructions. The Si534 is supplied in an industry-standard, RoHS compliant, 6-pad, 5 x 7 mm package.

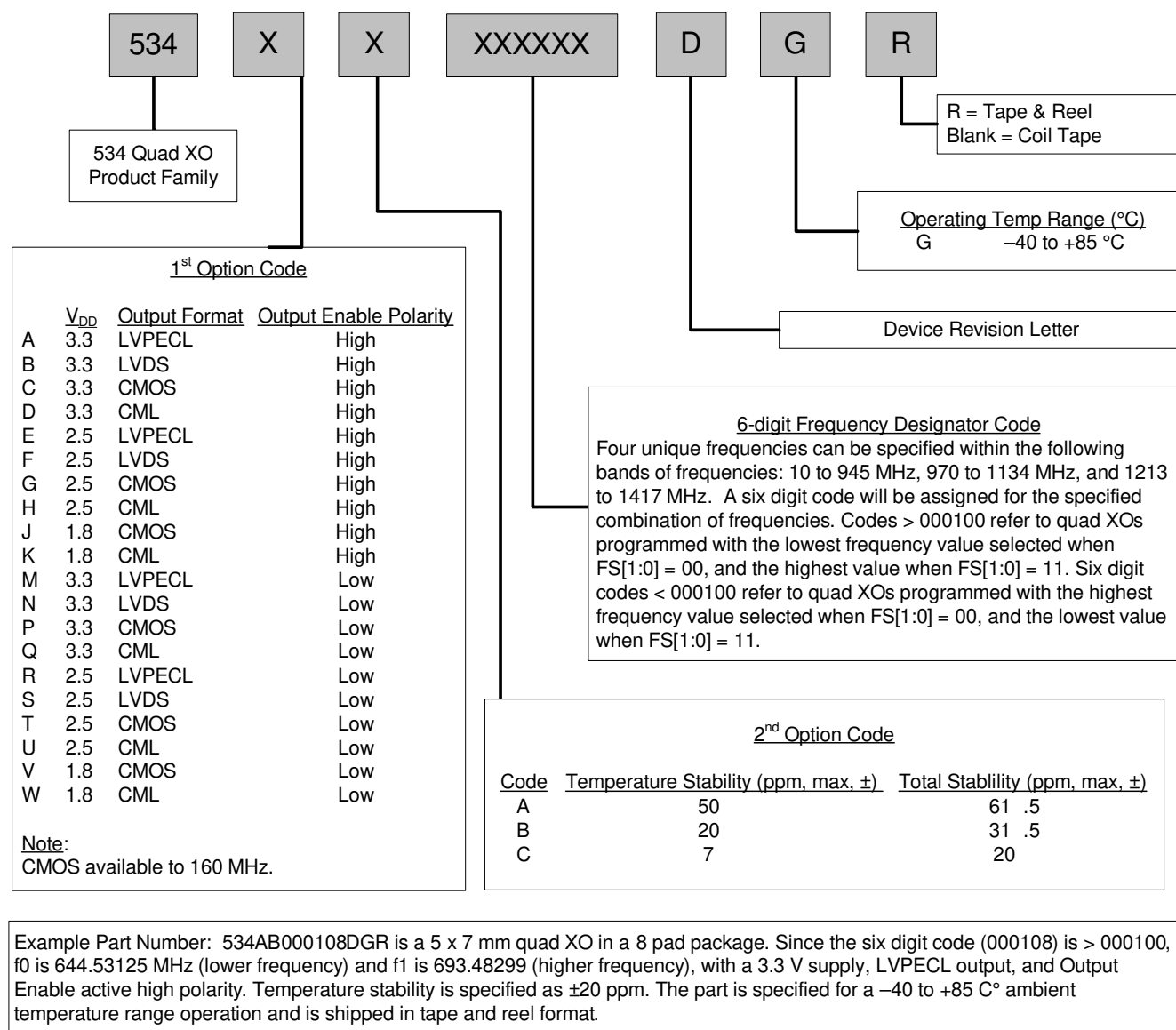

**Figure 1. Part Number Convention**

## 4. Outline Diagram and Suggested Pad Layout

Figure 2 illustrates the package details for the Si534. Table 11 lists the values for the dimensions shown in the illustration.

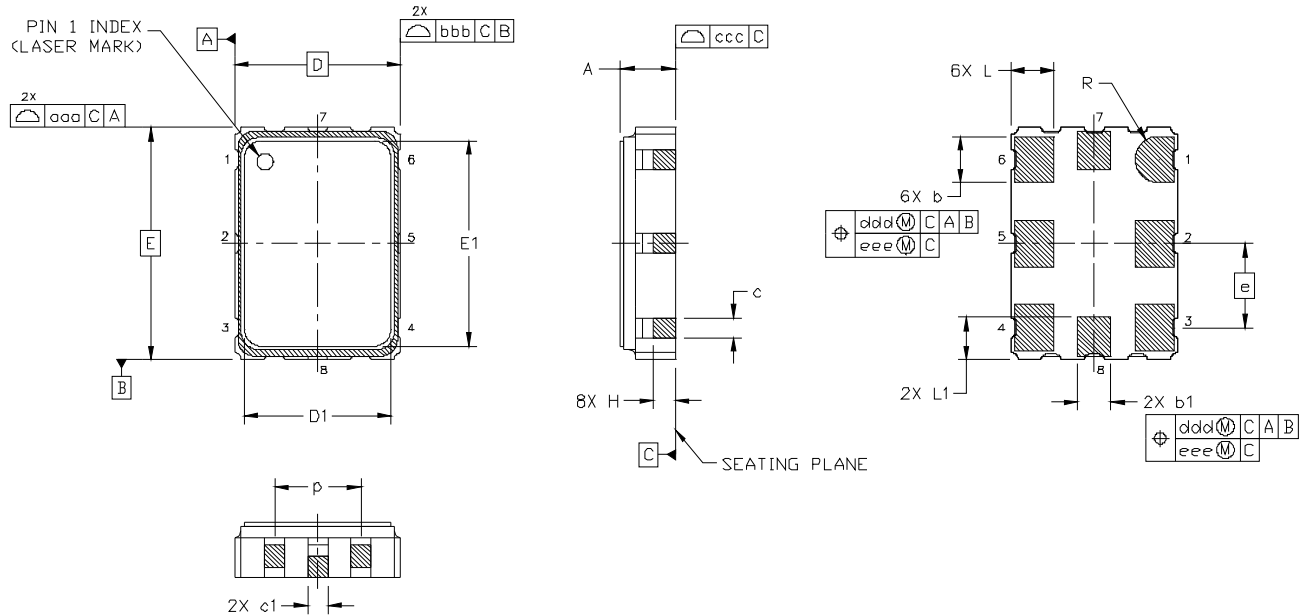

**Figure 2. Si534 Outline Diagram**

**Table 11. Package Diagram Dimensions (mm)**

Dimension	Min	Nom	Max
A	1.50	1.65	1.80
b	1.30	1.40	1.50
b1	0.90	1.00	1.10
c	0.50	0.60	0.70
c1	0.30	—	0.60
D	5.00 BSC		
D1	4.30	4.40	4.50
e	2.54 BSC		
E	7.00 BSC		
E1	6.10	6.20	6.30
H	0.55	0.65	0.75
L	1.17	1.27	1.37
L1	1.07	1.17	1.27
p	1.80	—	2.60
R	0.70 REF		
aaa	—	—	0.15
bbb	—	—	0.15
ccc	—	—	0.10
ddd	—	—	0.10
eee	—	—	0.05

**Note:**

1. All dimensions shown are in millimeters (mm) unless otherwise noted.
2. Dimensioning and Tolerancing per ANSI Y14.5M-1994.



## 5. Si534 Mark Specification

Figure 3 illustrates the mark specification for the Si534. Table 12 lists the line information.

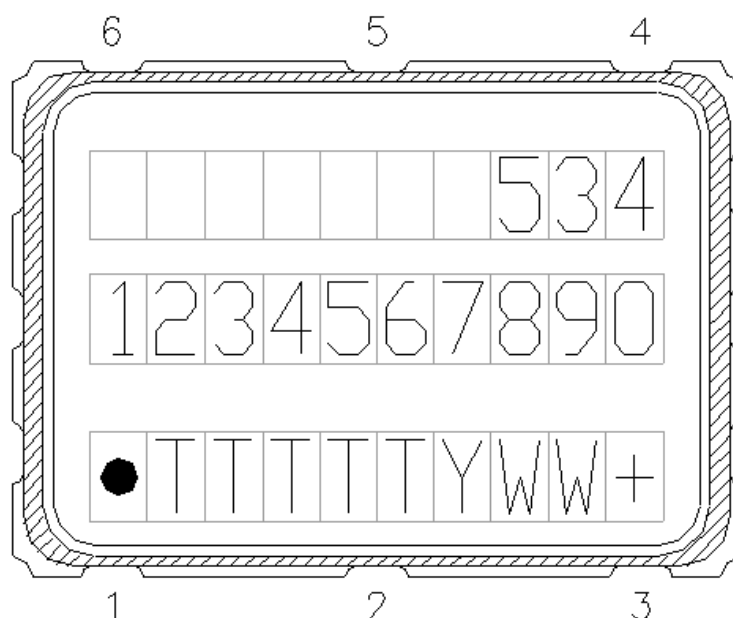

**Figure 3. Mark Specification**

**Table 12. Si53x Top Mark Description**

Line	Position	Description
1	1–10	“534”
2	1–10	Si530, Si531: Option1 + Option2 + Freq(7) + Temp Si532, Si533, Si534, Si530/Si531 w/ 8-digit resolution: Option1 + Option2 + ConfigNum(6) + Temp
3	<b>Trace Code</b>	
	Position 1	Pin 1 orientation mark (dot)
	Position 2	Product Revision (D)
	Position 3–6	Tiny Trace Code (4 alphanumeric characters per assembly release instructions)
	Position 7	Year (least significant year digit), to be assigned by assembly site (ex: 2007 = 7)
	Position 8–9	Calendar Work Week number (1–53), to be assigned by assembly site
	Position 10	“+” to indicate Pb-Free and RoHS-compliant

## 6. 8-Pin PCB Land Pattern

Figure 4 illustrates the 8-pin PCB land pattern for the Si554. Table 13 lists the values for the dimensions shown in the illustration.

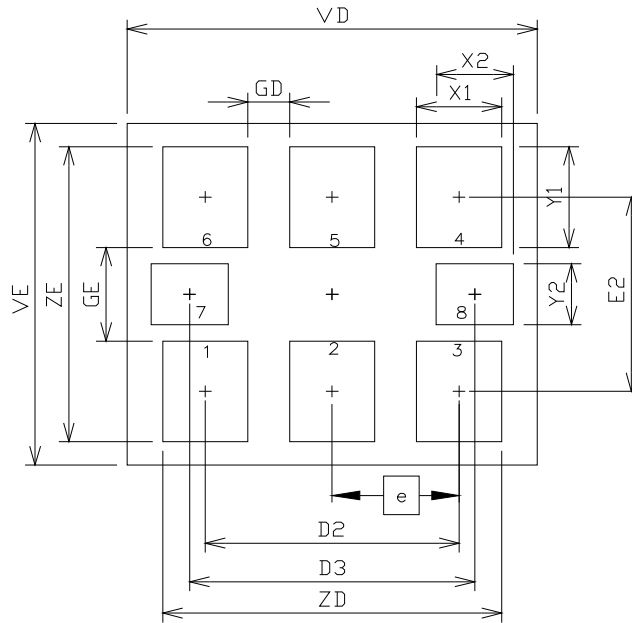

**Figure 4. Si534 PCB Land Pattern**

**Table 13. PCB Land Pattern Dimensions (mm)**

Dimension	Min	Max
D2	5.08 REF	
D3	5.705 REF	
e	2.54 BSC	
E2	4.20 REF	
GD	0.84	—
GE	2.00	—
VD	8.20 REF	
VE	7.30 REF	
X1	1.70 TYP	
X2	1.545 TYP	
Y1	2.15 REF	
Y2	1.3 REF	
ZD	—	6.78
ZE	—	6.30

**Note:**

1. Dimensioning and tolerancing per the ANSI Y14.5M-1994 specification.
2. Land pattern design follows IPC-7351 guidelines.
3. All dimensions shown are at maximum material condition (MMC).
4. Controlling dimension is in millimeters (mm).

## DOCUMENT CHANGE LIST

### Revision 1.0 to Revision 1.1

- Updated Table 1, “Recommended Operating Conditions,” on page 2.
  - Device maintains stable operation over  $-40$  to  $+85$  °C operating temperature range.
  - Supply current specifications updated for revision D.
- Updated Table 2, “CLK± Output Frequency Characteristics,” on page 2.
  - Added specification for  $\pm 20$  ppm lifetime stability ( $\pm 7$  ppm temperature stability) XO.
- Updated Table 3, “CLK± Output Levels and Symmetry,” on page 3.
  - Updated LVDS differential peak-peak swing specifications.
- Updated Table 4, “CLK± Output Phase Jitter,” on page 4.
- Updated Table 5, “CLK± Output Period Jitter,” on page 4.
  - Revised period jitter specifications.
- Updated Table 9, “Absolute Maximum Ratings<sup>1</sup>,” on page 5 to reflect the soldering temperature time at  $260$  °C is 20–40 sec per JEDEC J-STD-020C.
- Updated 3. “Ordering Information” on page 7.
  - Changed ordering instructions to revision D.
- Added 5. “Si534 Mark Specification” on page 9.

### Revision 1.1 to Revision 1.2

- Updated 2.5 V/3.3 V and 1.8 V CML output level specifications for Table 3 on page 3.
- Added footnotes clarifying max offset frequency test conditions for Table 4 on page 4.
- Removed the words “Differential Modes: LVPECL/LVDS/CML” in the footnote referring to AN256 in Table 4 on page 4.
- Added CMOS phase jitter specs to Table 4 on page 4.
- Updated ESD HBM sensitivity rating in Table 9 on page 5.
- Updated Table 7 on page 5 to include the “Moisture Sensitivity Level” and “Contact Pads” rows.
- Revised Figure 2 on page 8 to reflect current package outline diagram.
- Updated Figure 3 and Table 12 on page 9 to reflect specific marking information. Previously, Figure 3 was generic.

### Revision 1.2 to Revision 1.3

- Added Table 8, “Thermal Characteristics,” on page 5.

### Revision 1.3 to Revision 1.4

June, 2018

- Changed “Trays” to “Coil Tape” in section 3. “Ordering Information”.



## ClockBuilder Pro

One-click access to Timing tools, documentation, software, source code libraries & more. Available for Windows and iOS (CBGo only).

[skyworksinc.com/CBPro](http://skyworksinc.com/CBPro)



**Portfolio**

[skyworksinc.com](http://skyworksinc.com)



**SW/HW**

[skyworksinc.com/CBPro](http://skyworksinc.com/CBPro)

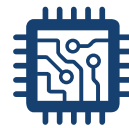

**Quality**

[skyworksinc.com/quality](http://skyworksinc.com/quality)



**Support & Resources**

[skyworksinc.com/support](http://skyworksinc.com/support)

**Copyright © 2022 Skyworks Solutions, Inc. All Rights Reserved.**

Information in this document is provided in connection with Skyworks Solutions, Inc. ("Skyworks") products or services. These materials, including the information contained herein, are provided by Skyworks as a service to its customers and may be used for informational purposes only by the customer. Skyworks assumes no responsibility for errors or omissions in these materials or the information contained herein. Skyworks may change its documentation, products, services, specifications or product descriptions at any time, without notice. Skyworks makes no commitment to update the materials or information and shall have no responsibility whatsoever for conflicts, incompatibilities, or other difficulties arising from any future changes.

No license, whether express, implied, by estoppel or otherwise, is granted to any intellectual property rights by this document. Skyworks assumes no liability for any materials, products or information provided hereunder, including the sale, distribution, reproduction or use of Skyworks products, information or materials, except as may be provided in Skyworks' Terms and Conditions of Sale.

THE MATERIALS, PRODUCTS AND INFORMATION ARE PROVIDED "AS IS" WITHOUT WARRANTY OF ANY KIND, WHETHER EXPRESS, IMPLIED, STATUTORY, OR OTHERWISE, INCLUDING FITNESS FOR A PARTICULAR PURPOSE OR USE, MERCHANTABILITY, PERFORMANCE, QUALITY OR NON-INFRINGEMENT OF ANY INTELLECTUAL PROPERTY RIGHT; ALL SUCH WARRANTIES ARE HEREBY EXPRESSLY DISCLAIMED. SKYWORKS DOES NOT WARRANT THE ACCURACY OR COMPLETENESS OF THE INFORMATION, TEXT, GRAPHICS OR OTHER ITEMS CONTAINED WITHIN THESE MATERIALS. SKYWORKS SHALL NOT BE LIABLE FOR ANY DAMAGES, INCLUDING BUT NOT LIMITED TO ANY SPECIAL, INDIRECT, INCIDENTAL, STATUTORY, OR CONSEQUENTIAL DAMAGES, INCLUDING WITHOUT LIMITATION, LOST REVENUES OR LOST PROFITS THAT MAY RESULT FROM THE USE OF THE MATERIALS OR INFORMATION, WHETHER OR NOT THE RECIPIENT OF MATERIALS HAS BEEN ADVISED OF THE POSSIBILITY OF SUCH DAMAGE

Skyworks products are not intended for use in medical, lifesaving or life-sustaining applications, or other equipment in which the failure of the Skyworks products could lead to personal injury, death, physical or environmental damage. Skyworks customers using or selling Skyworks products for use in such applications do so at their own risk and agree to fully indemnify Skyworks for any damages resulting from such improper use or sale.

Customers are responsible for their products and applications using Skyworks products, which may deviate from published specifications as a result of design defects, errors, or operation of products outside of published parameters or design specifications. Customers should include design and operating safeguards to minimize these and other risks. Skyworks assumes no liability for applications assistance, customer product design, or damage to any equipment resulting from the use of Skyworks products outside of Skyworks' published specifications or parameters.

Skyworks, the Skyworks symbol, Sky5®, SkyOne®, SkyBlue™, Skyworks Green™, Clockbuilder®, DSPLL®, ISOMODEM®, ProSLIC®, and SiPHY® are trademarks or registered trademarks of Skyworks Solutions, Inc. or its subsidiaries in the United States and other countries. Third-party brands and names are for identification purposes only and are the property of their respective owners. Additional information, including relevant terms and conditions, posted at [www.skyworksinc.com](http://www.skyworksinc.com), are incorporated by reference.

Skyworks Solutions, Inc. | Nasdaq: SWKS | [sales@skyworksinc.com](mailto:sales@skyworksinc.com) | [www.skyworksinc.com](http://www.skyworksinc.com)

USA: 781-376-3000 | Asia: 886-2-2735 0399 | Europe: 33 (0)1 43548540