



- Features :
- Universal AC input / Full range
 - Built-in active PFC function, PF>0.95
 - Protections: Short circuit / Overload / Over voltage / Over temperature
 - Forced air cooling by built-in DC Fan
 - Built-in fan speed control
 - Fixed switching frequency at 100KHz
 - 3 years warranty



SPECIFICATION

MODEL		SP-320-3.3	SP-320-5	SP-320-7.5	SP-320-12	SP-320-13.5	SP-320-15	SP-320-24	SP-320-27	SP-320-36	SP-320-48		
OUTPUT	DC VOLTAGE	3.3V	5V	7.5V	12V	13.5V	15V	24V	27V	36V	48V		
	RATED CURRENT	55A	55A	40A	25A	22A	20A	13A	11.7A	8.8A	6.7A		
	CURRENT RANGE	0 ~ 60A	0 ~ 55A	0 ~ 40A	0 ~ 25A	0 ~ 22A	0 ~ 20A	0 ~ 13A	0 ~ 11.7A	0 ~ 8.8A	0 ~ 6.7A		
	RATED POWER	181.5W	275W	300W	300W	297W	300W	312W	315.9W	316.8W	321.6W		
	RIPPLE & NOISE (max.) Note.2	150mVp-p	150mVp-p	150mVp-p	150mVp-p	150mVp-p	150mVp-p	150mVp-p	200mVp-p	220mVp-p	240mVp-p		
	VOLTAGE ADJ. RANGE	3.14 ~ 3.63V	4.5 ~ 5.5V	6 ~ 9V	10 ~ 13.2V	12 ~ 15V	13.5 ~ 18V	20 ~ 26.4V	26 ~ 31.5V	32.4 ~ 39.6V	41 ~ 56V		
	VOLTAGE TOLERANCE Note.3	±1.0%	±2.0%	±2.0%	±1.0%	±1.0%	±1.0%	±1.0%	±1.0%	±1.0%	±1.0%		
	LINE REGULATION	±0.5%	±0.5%	±0.5%	±0.3%	±0.3%	±0.3%	±0.2%	±0.2%	±0.2%	±0.2%		
	LOAD REGULATION	±1.5%	±1.0%	±1.0%	±0.5%	±0.5%	±0.5%	±0.5%	±0.5%	±0.5%	±0.5%		
	SETUP, RISE TIME	800ms, 50ms/230VAC		2500ms, 50ms/115VAC at full load									
HOLD UP TIME (Typ.)	16ms/230VAC		16ms/115VAC at full load										
INPUT	VOLTAGE RANGE Note.5	88 ~ 264VAC		124 ~ 370VDC									
	FREQUENCY RANGE	47 ~ 63Hz											
	POWER FACTOR (Typ.)	PF>0.95/230VAC		PF>0.98/115VAC at full load									
	EFFICIENCY (Typ.)	74%	79%	83%	86%	86%	86%	87%	88%	87%	89%		
	AC CURRENT (Typ.)	115VAC	2.5A	5A									
		230VAC	1.5A	2.5A									
	INRUSH CURRENT (Typ.)	20A/115VAC		40A/230VAC									
LEAKAGE CURRENT	<1mA / 240VAC												
PROTECTION	OVERLOAD	105 ~ 135% rated output power Protection type : Hiccup mode, recovers automatically after fault condition is removed											
	OVER VOLTAGE	3.8 ~ 4.5V	5.75 ~ 6.75V	9.4 ~ 10.9V	13.8 ~ 16.2V	15.5 ~ 18.2V	18 ~ 21V	27.6 ~ 32.4V	33.7 ~ 39.2V	45 ~ 52.5V	57.6 ~ 67.2V		
	OVER TEMPERATURE	Shut down o/p voltage, recovers automatically after temperature goes down											
ENVIRONMENT	WORKING TEMP.	-20 ~ +65°C (Refer to "Derating Curve")											
	WORKING HUMIDITY	20 ~ 90% RH non-condensing											
	STORAGE TEMP., HUMIDITY	-40 ~ +85°C, 10 ~ 95% RH											
	TEMP. COEFFICIENT	±0.03%/°C (0 ~ 50°C)											
	VIBRATION	10 ~ 500Hz, 2G 10min./1cycle, 60min. each along X, Y, Z axes											
SAFETY & EMC (Note 4)	SAFETY STANDARDS	UL60950-1 approved											
	WITHSTAND VOLTAGE	I/P-O/P:3KVAC I/P-FG:2KVAC O/P-FG:0.5KVAC											
	ISOLATION RESISTANCE	I/P-O/P, I/P-FG, O/P-FG:100M Ohms / 500VDC / 25°C / 70% RH											
	EMC EMISSION	Compliance to EN55032 (CISPR32) Class B, EN61000-3-2,-3											
	EMC IMMUNITY	Compliance to EN61000-4-2,3,4,5,6,8,11, EN55024, light industry level, criteria A											
OTHERS	MTBF	207K hrs min. MIL-HDBK-217F (25°C)											
	DIMENSION	215*115*50mm (L*W*H)											
	PACKING	1.1Kg; 12pcs/14Kg/0.9CUFT											
NOTE	<p>1. All parameters NOT specially mentioned are measured at 230VAC input, rated load and 25°C of ambient temperature.</p> <p>2. Ripple & noise are measured at 20MHz of bandwidth by using a 12" twisted pair-wire terminated with a 0.1uf & 47uf parallel capacitor.</p> <p>3. Tolerance : includes set up tolerance, line regulation and load regulation.</p> <p>4. The power supply is considered a component which will be installed into a final equipment. All the EMC tests are been executed by mounting the unit on a 360mm*360mm metal plate with 1mm of thickness. The final equipment must be re-confirmed that it still meets EMC directives. For guidance on how to perform these EMC tests, please refer to "EMI testing of component power supplies." (as available on http://www.meanwell.com)</p> <p>5. Derating may be needed under low input voltages. Please check the derating curve for more details.</p> <p>※ Product Liability Disclaimer : For detailed information, please refer to https://www.meanwell.com/serviceDisclaimer.aspx</p>												

Mechanical Specification

Case No. 912G Unit:mm

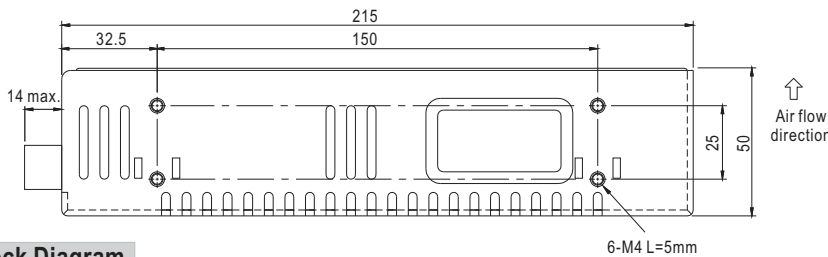
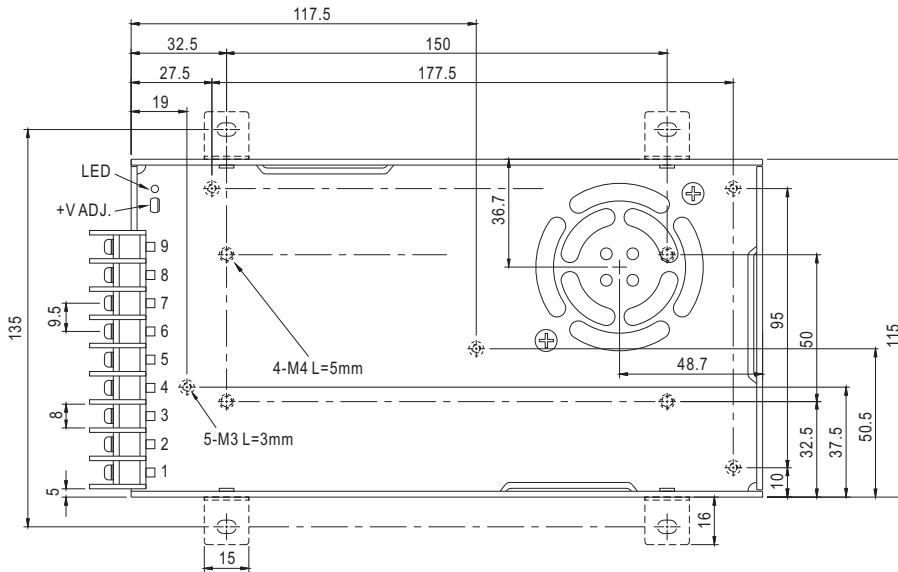

Terminal Pin No. Assignment :

Pin No.	Assignment	Pin No.	Assignment
1	AC/L	4~6	DC OUTPUT -V
2	AC/N	7~9	DC OUTPUT +V
3	FG \perp		

Block Diagram

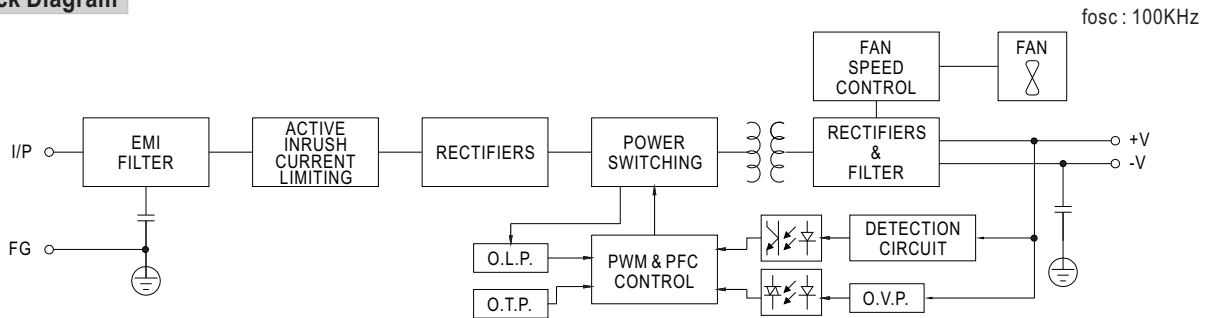

Derating Curve

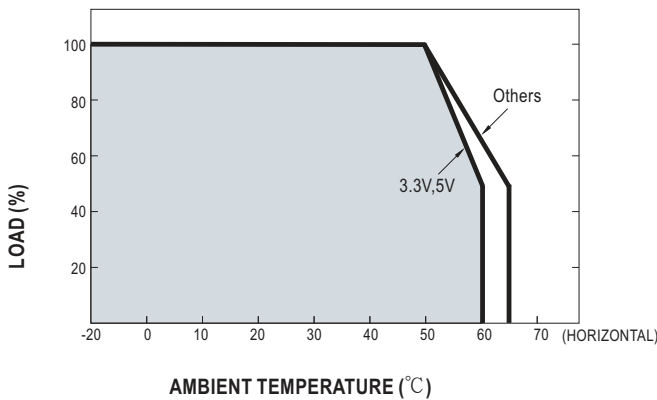

Static Characteristics

