

TR4

FPGA Development Kit

User Manual

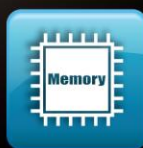
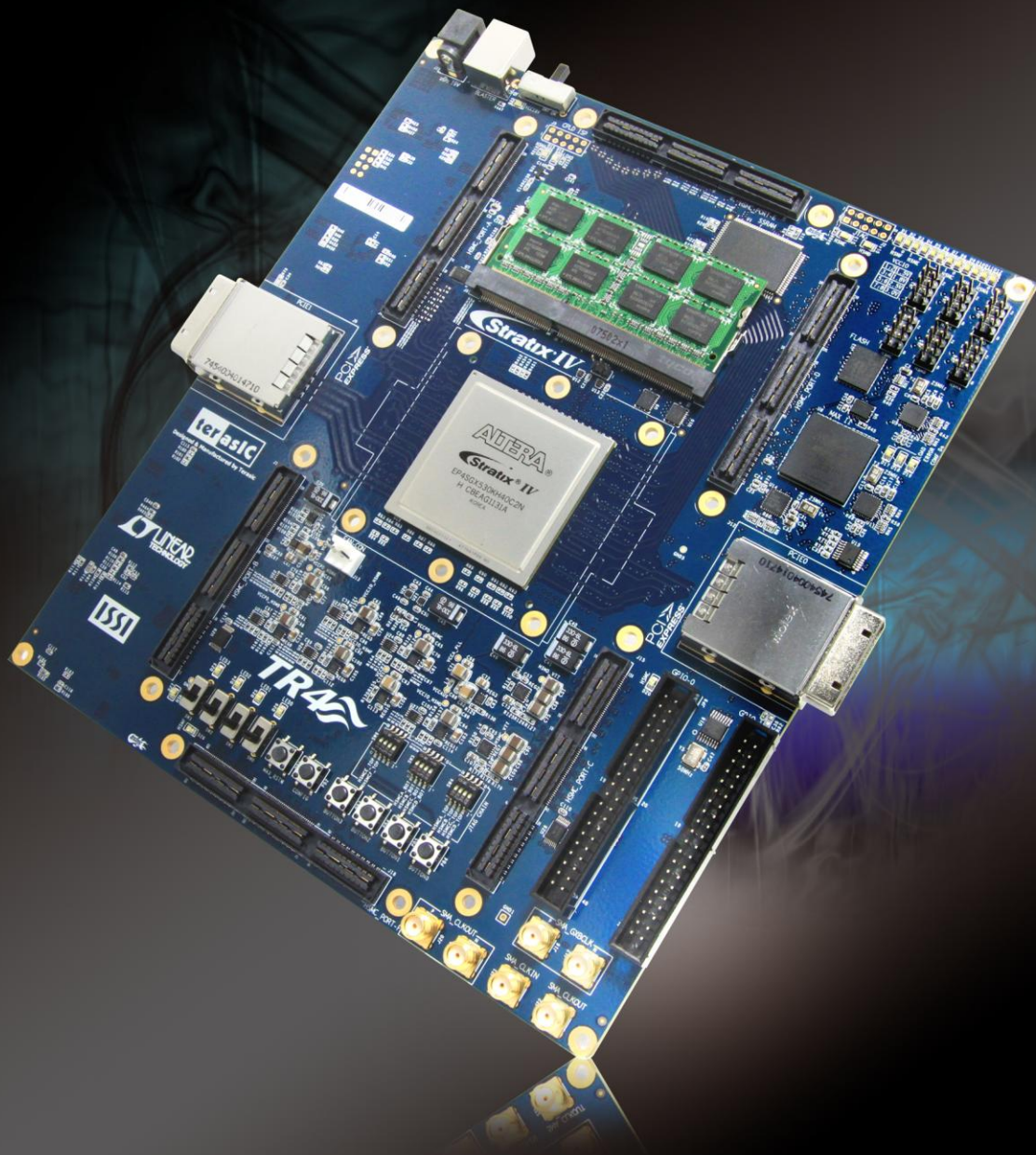

CHAPTER 1	<i>OVERVIEW</i>	1
1.1	GENERAL DESCRIPTION	1
1.2	KEY FEATURES	2
1.3	BOARD OVERVIEW	3
1.4	BLOCK DIAGRAM	4
1.5	ASSEMBLY	8
CHAPTER 2	<i>USING THE TR4 BOARD</i>	9
2.1	CONFIGURATION OPTIONS	9
2.2	SETUP ELEMENTS	16
2.3	STATUS ELEMENTS	16
2.4	GENERAL USER INPUT/OUTPUT	17
2.5	HIGH-SPEED MEZZANINE CARDS	19
2.6	GPIO EXPANSION HEADERS	31
2.7	DDR3 SO-DIMM	35
2.8	CLOCK CIRCUITRY	39
2.9	PCI EXPRESS	44
2.10	FLASH MEMORY	47
2.11	SSRAM MEMORY	50
2.12	TEMPERATURE SENSOR AND FAN	52
2.13	POWER	52
2.14	SECURITY	53
2.15	USING EXTERNAL BLASTER	53
CHAPTER 3	<i>CONTROL PANEL</i>	55
3.1	CONTROL PANEL SETUP	55
3.2	CONTROLLING THE LEDs	59
3.3	SWITCHES AND PUSH-BUTTONS	60
3.4	MEMORY CONTROLLER	61
3.5	TEMPERATURE MONITOR	64
3.6	PLL	65
3.7	HSMC	66

3.8 FAN	67
3.9 INFORMATION	68
CHAPTER 4 TR4 SYSTEM BUILDER.....	70
4.1 INTRODUCTION	70
4.2 GENERAL DESIGN FLOW	71
4.3 USING TR4 SYSTEM BUILDER.....	72
CHAPTER 5 EXAMPLES OF ADVANCED DEMONSTRATION.....	82
5.1 FIX QSYS ISSUE FOR QUARTUS 20.1.1	82
5.2 BREATHING LEDs.....	83
5.3 EXTERNAL CLOCK GENERATOR	84
5.4 HIGH SPEED MEZZANINE CARD (HSMC)	90
5.5 DDR3 SDRAM (1GB)	92
5.6 DDR3 SDRAM (4GB)	96
5.7 SSRAM TEST	99
CHAPTER 6 PCI EXPRESS REFERENCE DESIGN FOR WINDOWS.....	103
6.1 PCI EXPRESS SYSTEM INFRASTRUCTURE.....	103
6.2 PC PCI EXPRESS SOFTWARE SDK	104
6.3 PCI EXPRESS SOFTWARE STACK	105
6.4 PCI EXPRESS LIBRARY API.....	112
6.5 PCIe REFERENCE DESIGN - FUNDAMENTAL.....	117
6.6 PCIe REFERENCE DESIGN – DDR3	125
CHAPTER 7 PCI EXPRESS REFERENCE DESIGN FOR LINUX.....	132
7.1 PCI EXPRESS SYSTEM INFRASTRUCTURE.....	132
7.2 PC PCI EXPRESS SOFTWARE SDK	133
7.3 PCI EXPRESS SOFTWARE STACK	134
7.4 PCIe LIBRARY API	136
7.5 PCIe REFERENCE DESIGN - FUNDAMENTAL.....	137
7.6 PCIe REFERENCE DESIGN - DDR3.....	143
CHAPTER 8 APPENDIX A: HSMC PIN ASSIGNMENT.....	154
ADDITIONAL INFORMATION.....	169

This chapter provides an overview of the TR4 Development Board and details the components and features of the board.

1.1 General Description

The TR4 Development Board provides the ideal hardware platform for system designs that demand high-performance, serial connectivity, and advanced memory interfacing. Developed specifically to address the rapidly evolving requirements in many end markets for greater bandwidth, improved jitter performance, and lower power consumption, the TR4 is powered by the Stratix® IV GX device and supported by industry-standard peripherals, connectors and interfaces that offer a rich set of features that is suitable for a wide range of compute-intensive applications.

The advantages of the Stratix® IV GX FPGA platform with integrated transceivers have allowed the TR4 to be fully compliant with version 2.0 of the PCI Express standard. This will accelerate mainstream development of PCI Express-based applications and enable customers to deploy designs for a broad range of high-speed connectivity applications.

The TR4 is supported by multiple reference designs and six High-Speed Mezzanine Card (HSMC) connectors that allow scaling and customization with mezzanine daughter cards. For large-scale ASIC prototype development, multiple TR4s can be stacked together to create an easily-customizable multi-FPGA system.

1.2 Key Features

Featured Device

- Altera Stratix® IV GX FPGA (EP4SGX230C2/EP4SGX530C2)

Configuration and Set-up Elements

- Built-in USB Blaster circuit for programming
- Fast passive parallel (FPP) configuration via MAX II CPLD and FLASH

Components and Interfaces

- Six HSMC connectors (two with transceiver support)
- Two 40-pin GPIO expansion headers (shares pins with HSMC Port C)
- Two external PCI Express 2.0 (x4 lane) connectors

Memory

- DDR3 SO-DIMM socket (8GB Max)
- 64MB FLASH
- 2MB SSRAM

General User Input/Output:

- Four LEDs
- Four push-buttons
- Four slide switches

Clock system

- On-board 50MHz oscillator
- Three on-board programmable PLL timing chips
- SMA connector pair for differential clock input
- SMA connector pair for differential clock output
- SMA connector for external clock input

- SMA connector for clock output

Other

- Temperature sensor
- FPGA cooling fan

1.3 Board Overview

Figure 1-1 and Figure 1-2 show the top and bottom view of the TR4 board. It depicts the layout of the board and indicates the location of the connectors and key components. Users can refer to these figures for relative location when the connectors and key components are introduced in the following chapters.

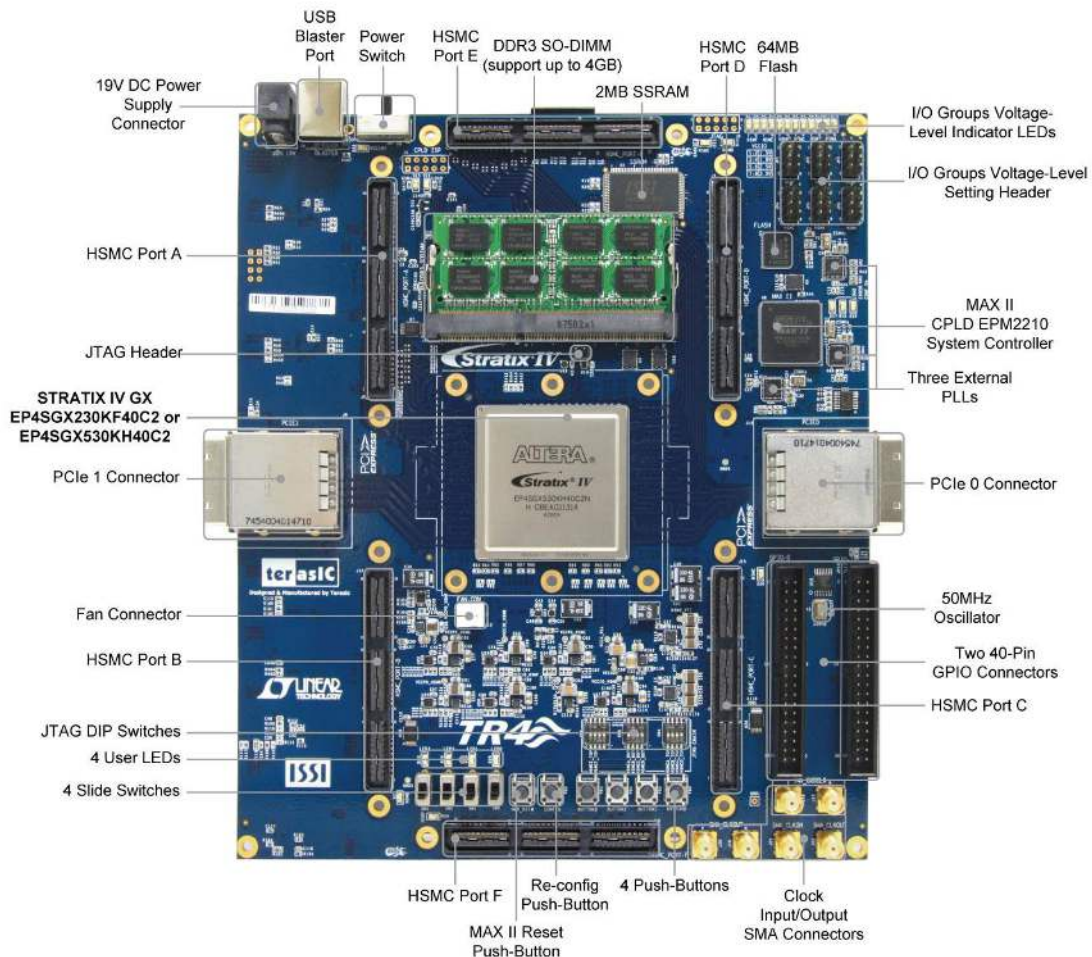

Figure 1-1 TR4 Board View (Top)

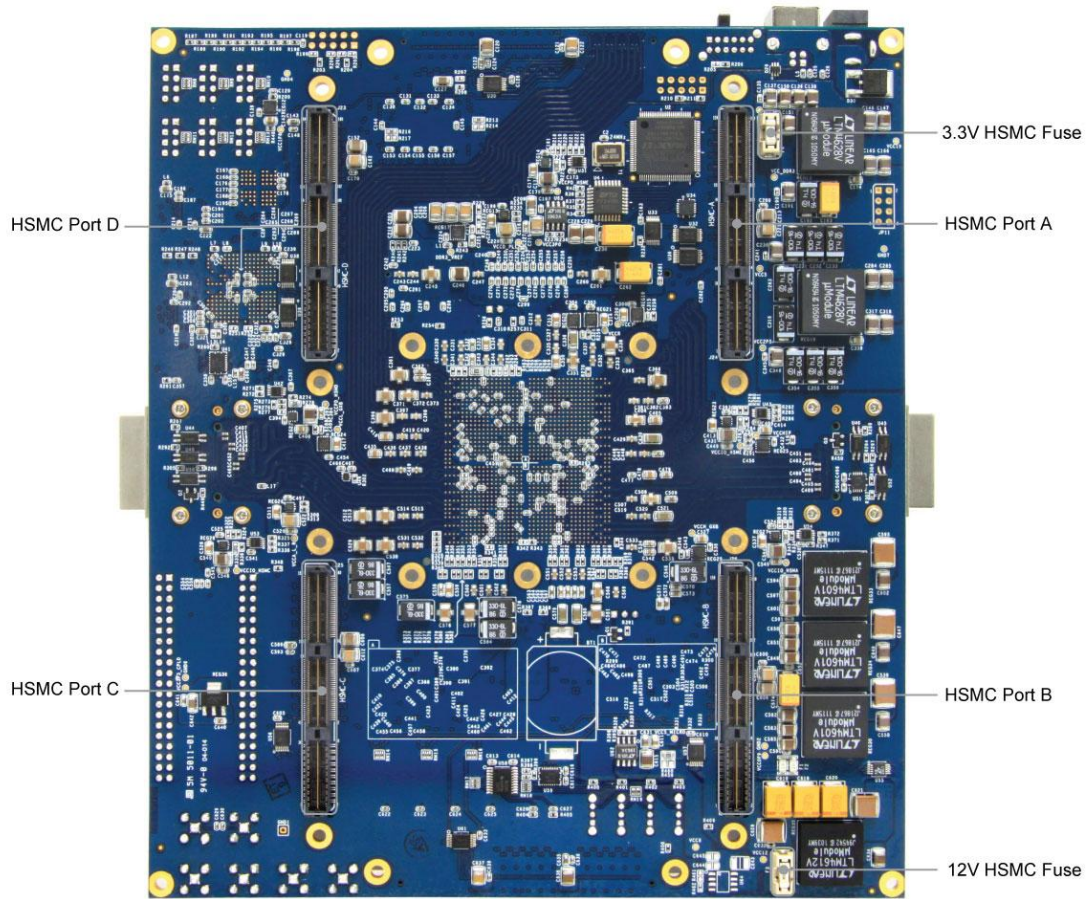

Figure 1-2 TR4 Board View (Bottom)

1.4 Block Diagram

Figure 1-3 shows the block diagram of the TR4 board. To provide maximum flexibility for the users, all key components are connected with the Stratix IV GX FPGA device, allowing the users to implement any system design.

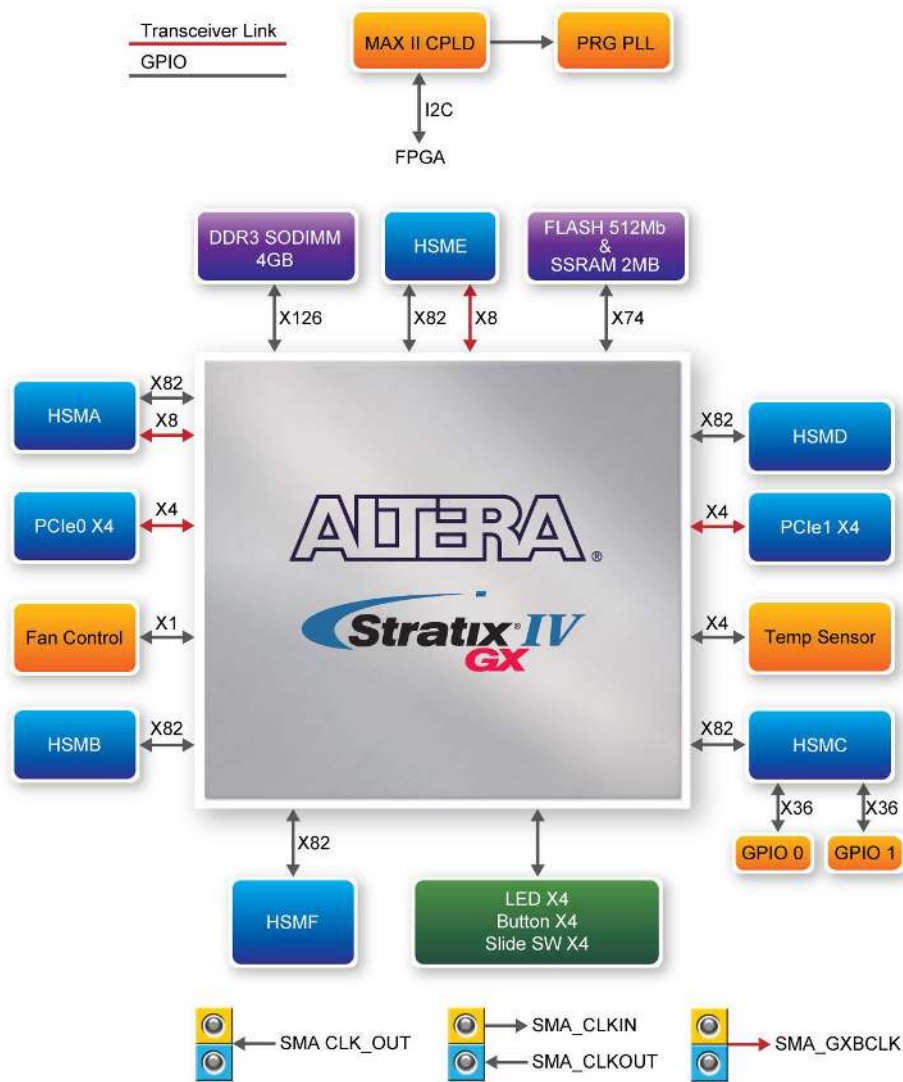

Figure 1-3 TR4 Block Diagram

Below is more detailed information regarding the blocks in **Figure 1-3**.

Stratix IV GX FPGA

EP4SGX230C2

- 228,000 logic elements (LEs)
- 17,133 total memory Kb
- 1,288 18x18-bit multipliers blocks
- 2 PCI Express hard IP blocks

- 744 user I/Os
- 8 phase locked loops (PLLs)

EP4SGX530C2

- 531,200 logic elements (LEs)
- 27,376K total memory Kb
- 1,024 18x18-bit multipliers blocks
- 4 PCI Express hard IP blocks
- 744 user I/Os
- 8 phase locked loops (PLLs)

Configuration Device and USB Blaster Circuit

- MAXII CPLD EPM2210 System Controller and Fast Passive Parallel (FPP) configuration
- On-board USB Blaster for use with the Quartus II Programmer
- Programmable PLL timing chip configured via MAX II CPLD
- Supports JTAG mode

Memory Devices

- 64MB Flash (32M x16) with a 16-bit data bus
- 2MB SSRAM (512K x 32)

DDR3 SO-DIMM Socket

- Up to 8GB capacity
- Maximum memory clock rate at 533MHz
- Theoretical bandwidth up to 68Gbps

LEDs

- 4 user-controllable LEDs
- Active-low|

Push-buttons

- 4 user-defined inputs
- Active-low

Slide Switches

- 4 slide switches for user-defined inputs
- Logic low for DOWN position; Logic high for UP position

On-Board Clocking Circuitry

- 50MHz oscillator
- SMA connector pair for differential clock inputs
- SMA connector pair for differential clock outputs
- SMA connector for external clock input
- SMA connector for clock output

Two PCI Express x4 Edge Connectors

- Support connection speed of Gen1 at 2.5Gbps/lane to Gen2 at 5.0Gbps/lane
- Support downstream mode

Six High Speed Mezzanine Card (HSMC) Connectors

- Two HSMC ports include 16 pairs of CDR-based transceivers at data rates of up to 6.5Gbps
- Among HSMC Port A to D, there are 55 true LVDS TX channels to 1.6Gbps and 17 emulated LVDS TX channels up to 1.1Gbps whereas there are 9 additional TX channels from HSMC Port E.
- Configurable I/O standards - 1.5V, 1.8V, 2.5V, 3.0V

Two 40-pin GPIO Expansion Headers

- 72 FPGA I/O pins; 4 power and ground lines
- Shares pins with HSMC Port C
- Configurable I/O standards: 1.5V, 1.8V, 2.5V, 3.0V

Power

- Standalone DC 19V input

Other

- Temperature Sensor
- Cooling Fan

1.5 Assembly

Attach the included rubber (silicon) foot stands, as shown in **Figure 1-4**, to each of the four copper stands on the TR4 board.



Figure 1-4 Mount Silicon Foot Stands

Chapter 2

Using the TR4 Board

This chapter gives instructions for using the TR4 board and its components.

It is strongly recommended that users read the *TR4 Getting Started Guide.pdf* before operating the TR4 board. The document is located in the *Usermanual* folder on the **TR4 System CD**. The contents of the document include the following:

- Introduction to the TR4 Development Board
- TR4 Development Kit Contents
- Key Features
- Before You Begin
- Software Installation
- Development Board Setup
- Programming the Stratix IV GX Device
- Programming through Flash

2.1 Configuration Options

■ JTAG FPGA Programming with USB-Blaster

The USB-blaster is implemented on the TR4 board to provide a JTAG configuration through the on-board USB-to-JTAG configuration logic through the type-B USB connector, an FTDI USB 2.0 PHY device, and an Altera MAX II CPLD. For this programming mode, configuration data will be lost when the power is turned off.

To download a configuration bit stream into the Stratix IV GX FPGA, perform the following steps:

- Make sure that power is provided to the TR4 board.
- Open JP7 to bypass the JTAG interface of the HSMC if it won't be used.
- Connect the USB cable supplied directly to the USB Blaster port of the TR4 board (see [Figure 2-1](#)).
- The FPGA can now be programmed in the Quartus II Programmer by selecting a configuration bit stream file with the .sof filename extension.
- If users need to use the JTAG interface on HSMC, please refer to Section 2.2 for detailed HSMC JTAG switch settings.

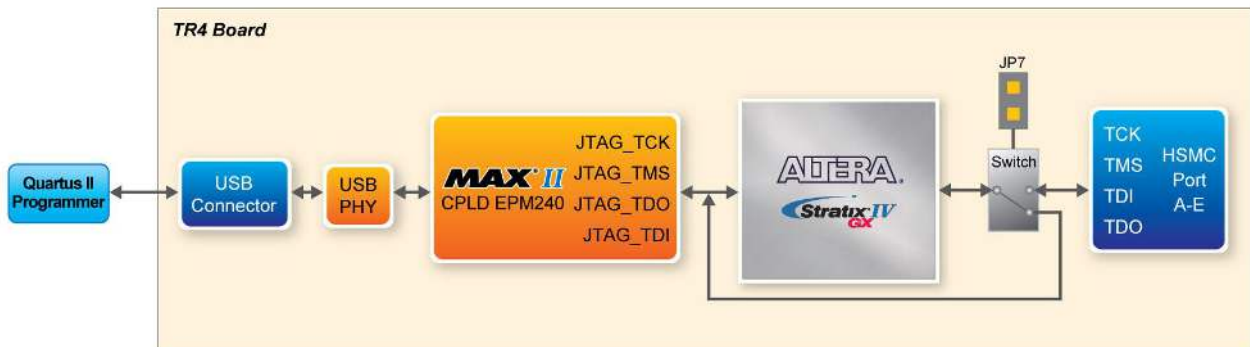

Figure 2-1 JTAG Configuration Scheme

■ JTAG FPGA Programming with External Blaster

The TR4 board supports JTAG programming over external blaster via J2. To use this interface, users need to solder a 2x5 pin connector (2.54mm pitch) to J2. Make sure JP7 is open to bypass the JTAG interface of HSMC.

■ Flash Programming

The TR4 development board contains a common Flash interface (CFI) memory to meet the demands for larger FPGA configurations. The Parallel Flash Loader (PFL) feature in MAX II devices provides an efficient method to program CFI flash memory devices through the JTAG interface and the logic to control configuration from the flash memory device to the Stratix IV GX FPGA. [Figure 2-2](#) depicts the connection setup between the CFI flash memory, Max II CPLD, and Stratix IV GX.

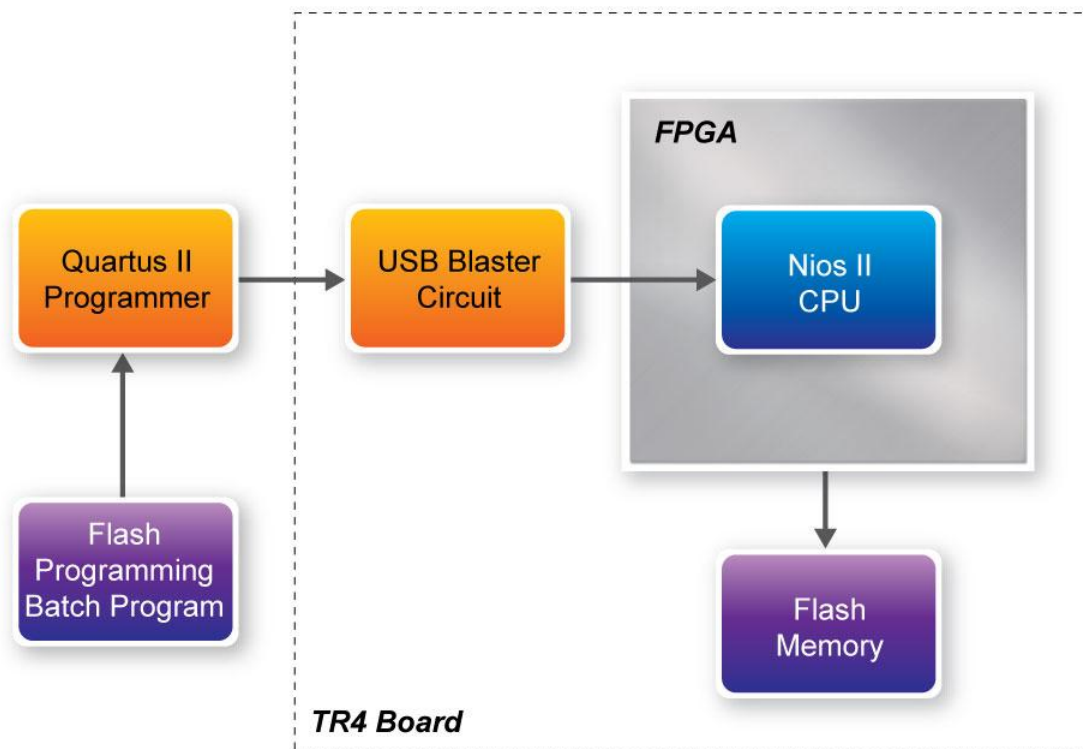

Figure 2-2 Flash Programming Scheme

■ Programming Flash Memory using Batch File

The TR4 provides a batch file (program_Flash.bat) to limit the steps that are taken when users program the flash memory on the TR4.

■ Software Requirements:

- Quartus Prime 20.1.1 Standard Edition
- Nios II EDS 20.1.1

Note :

- Nios II EDS on Windows requires Ubuntu 18.04 LTS on Windows Subsystem for Linux (WSL), which requires user to install it manually. Please refer to the link for installation : http://www.terasic.com.tw/wiki/Getting_Start_Install_WSL
- Nios II EDS requires you to install an Eclipse IDE manually.

- Program_Flash folder contents:
- Program_Flash.bat
- Program_Flash.pl
- Program_Flash.sh
- tr4_default_flash_loader.sof
- boot_loader_cfi.srec

Before you use the program_Flash.bat batch file to program the flash memory, make sure the TR4 is turned on and USB cable is connected to the USB blaster port (J4). In addition, place the .sof and .elf file you wish to program/convert in the *Program_Flash* directory.

Programming Flash Memory with .sof using Program_Flash.bat

1. Launch the program_Flash.bat batch file from the directory (*demonstrations\TR4_<Stratix device>\TR4_Default_Flash_Loader\Program_Flash*) of the **TR4 system CD-ROM**.
2. The Flash program tool shows the menu options.

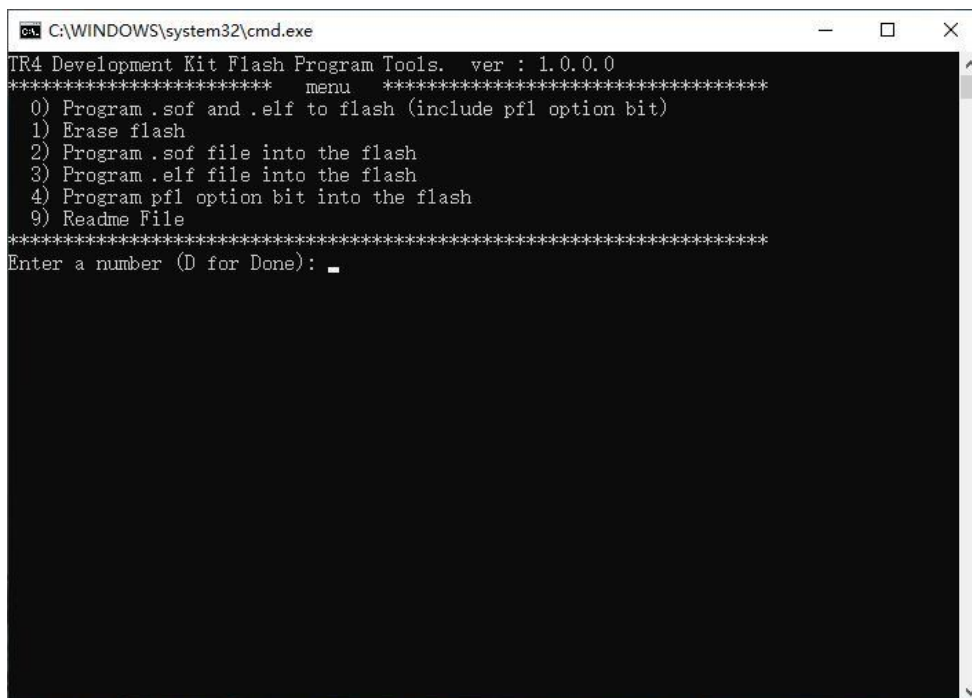
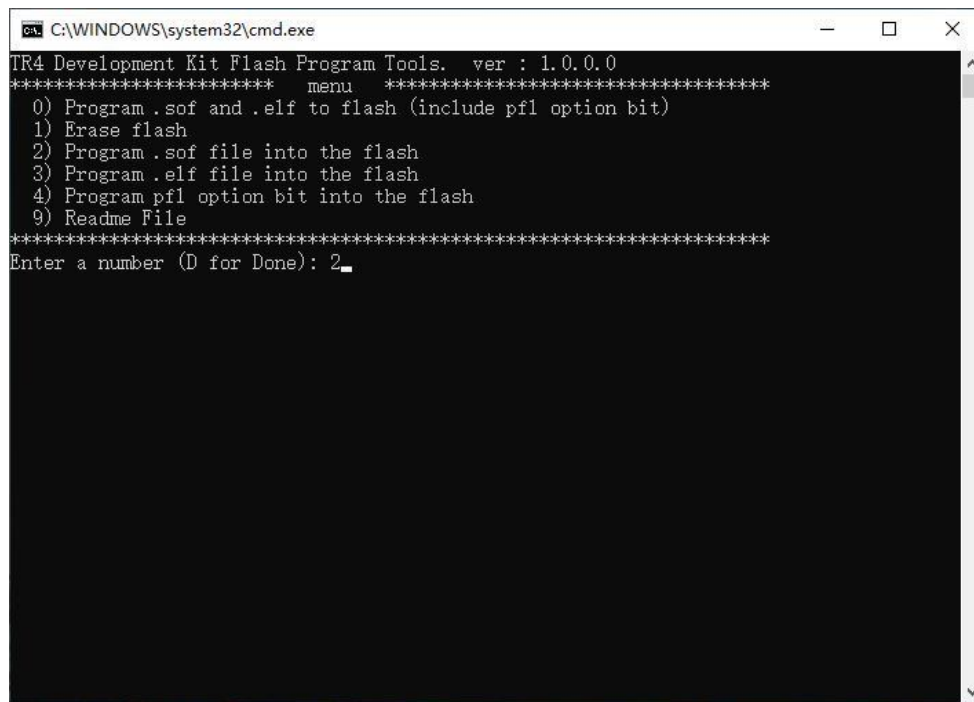

Figure 2-3 Flash Program Tools

3. Select option 2.



```
C:\WINDOWS\system32\cmd.exe
TR4 Development Kit Flash Program Tools. ver : 1.0.0.0
***** menu *****
0) Program .sof and .elf to flash (include pfl option bit)
1) Erase flash
2) Program .sof file into the flash
3) Program .elf file into the flash
4) Program pfl option bit into the flash
9) Readme File
*****
Enter a number (D for Done): 2_
```

Figure 2-4 Option 2

4. Enter the .sof file name to be programmed onto the flash memory.

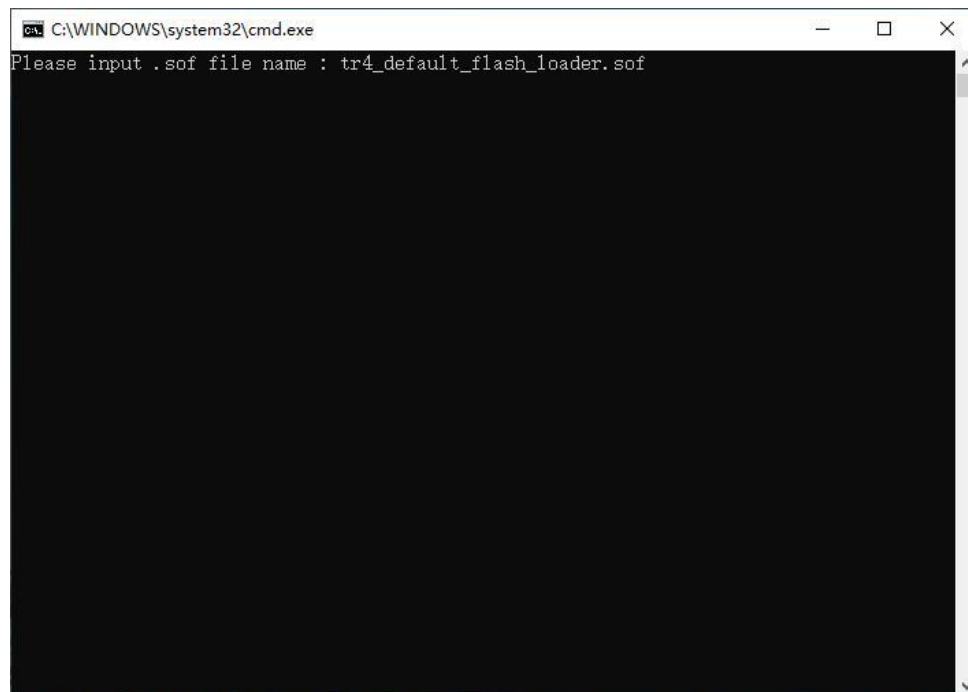

```
C:\WINDOWS\system32\cmd.exe
Please input .sof file name : tr4_default_flash_loader.sof
```

Figure 2-5 Enter .sof Name to Program

5. The following lines will appear during Flash programming: ‘Extracting Option bits SREC’, ‘Extracting FPGA Image SREC’, and ‘Deleting intermediate files’. If these lines don’t appear on the windows command, programming on the flash memory is not successfully set up. Please make sure Quartus II 11.1 and Nios II 11.1 IDE or later is used.

```

C:\intel\FPGA\20.1.1\quartus\bin64\quartus_pgm.exe
Please input .sof file name : tr4_default_flash_loader.sof
Start file conversion, please wait a few minutes ...
underfor Quartus 20.1

Extracting Option bits SREC
Extracting FPGA Image SREC
Deleting intermediate files
Modify tr4_hw.map.flash file ok.

Load board update portal file into FPGA, please wait ...

Info: *****
Info: Running Quartus Prime Programmer
Info: Version 20.1.1 Build 720 11/11/2020 SJ Standard Edition
Info: Copyright (C) 2020 Intel Corporation. All rights reserved.
Info: Your use of Intel Corporation's design tools, logic functions
Info: and other software and tools, and any partner logic
Info: functions, and any output files from any of the foregoing
Info: (including device programming or simulation files), and any
Info: associated documentation or information are expressly subject
Info: to the terms and conditions of the Intel Program License
Info: Subscription Agreement, the Intel Quartus Prime License Agreement,
Info: the Intel FPGA IP License Agreement, or other applicable license
Info: agreement, including, without limitation, that your use is for
Info: the sole purpose of programming logic devices manufactured by
Info: Intel and sold by Intel or its authorized distributors. Please

```

Figure 2-6 Loading .sof File

6. Erasing Flash.

```

C:\intel\FPGA\20.1.1\quartus\bin64\nios2-flash-programmer.exe
012C0000 : Reading existing contents
012E0000 : Reading existing contents
01300000 : Reading existing contents
01320000 : Reading existing contents
01340000 : Reading existing contents
01360000 : Reading existing contents
013A0000 : Reading existing contents
013C0000 : Reading existing contents
013E0000 : Reading existing contents
01400000 : Reading existing contents
01460000 : Reading existing contents
01480000 : Reading existing contents
Checksummed/read 3498kB in 0.3s
00020000 ( 0): Erasing
00040000 ( 0): Erasing
00060000 ( 1): Erasing
00080000 ( 2): Erasing
000A0000 ( 2): Erasing
000E0000 ( 3): Erasing
00100000 ( 4): Erasing
00120000 ( 5): Erasing
00140000 ( 5): Erasing
00160000 ( 6): Erasing
00180000 ( 7): Erasing
001A0000 ( 8): Erasing
001C0000 ( 8): Erasing
001E0000 ( 9): Erasing
00200000 (10): Erasing
00220000 (10): Erasing
00240000 (11): Erasing

```

Figure 2-7 Erasing Flash

7. Programming Flash.

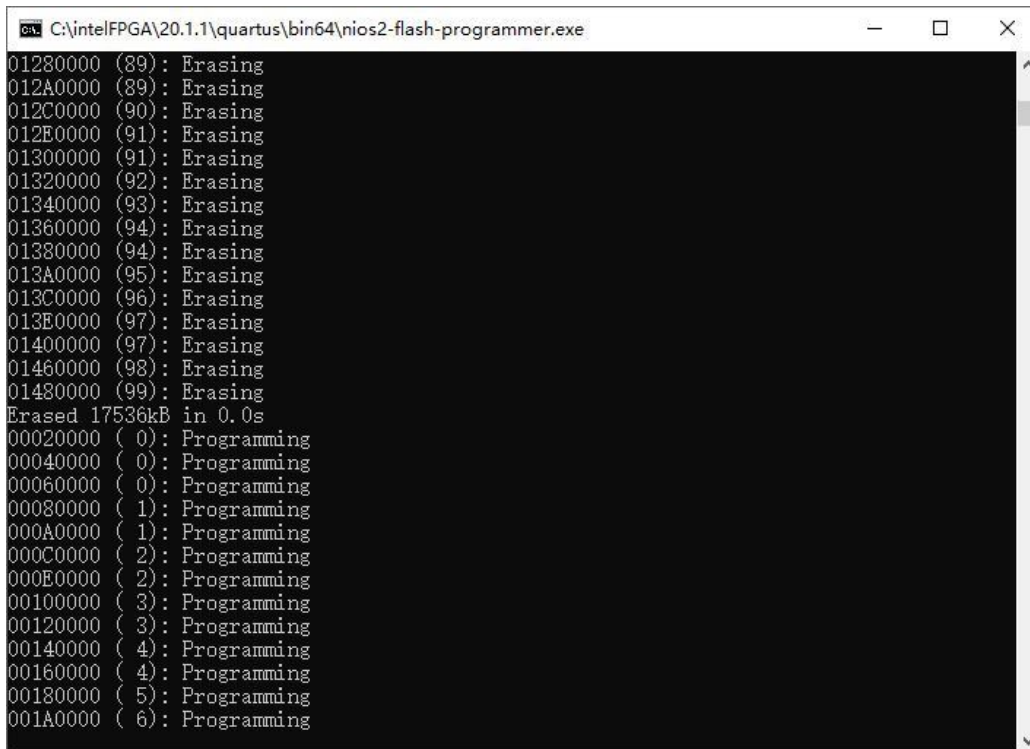

```
C:\intelFPGA\20.1.1\quartus\bin64\nios2-flash-programmer.exe
01280000 (89): Erasing
012A0000 (89): Erasing
012C0000 (90): Erasing
012E0000 (91): Erasing
01300000 (91): Erasing
01320000 (92): Erasing
01340000 (93): Erasing
01360000 (94): Erasing
01380000 (94): Erasing
013A0000 (95): Erasing
013C0000 (96): Erasing
013E0000 (97): Erasing
01400000 (97): Erasing
01460000 (98): Erasing
01480000 (99): Erasing
Erased 17536kB in 0.0s
00020000 ( 0): Programming
00040000 ( 0): Programming
00060000 ( 0): Programming
00080000 ( 1): Programming
000A0000 ( 1): Programming
000C0000 ( 2): Programming
000E0000 ( 2): Programming
00100000 ( 3): Programming
00120000 ( 3): Programming
00140000 ( 4): Programming
00160000 ( 4): Programming
00180000 ( 5): Programming
001A0000 ( 6): Programming
```

Figure 2-8 Programming Flash

8. Programming complete.

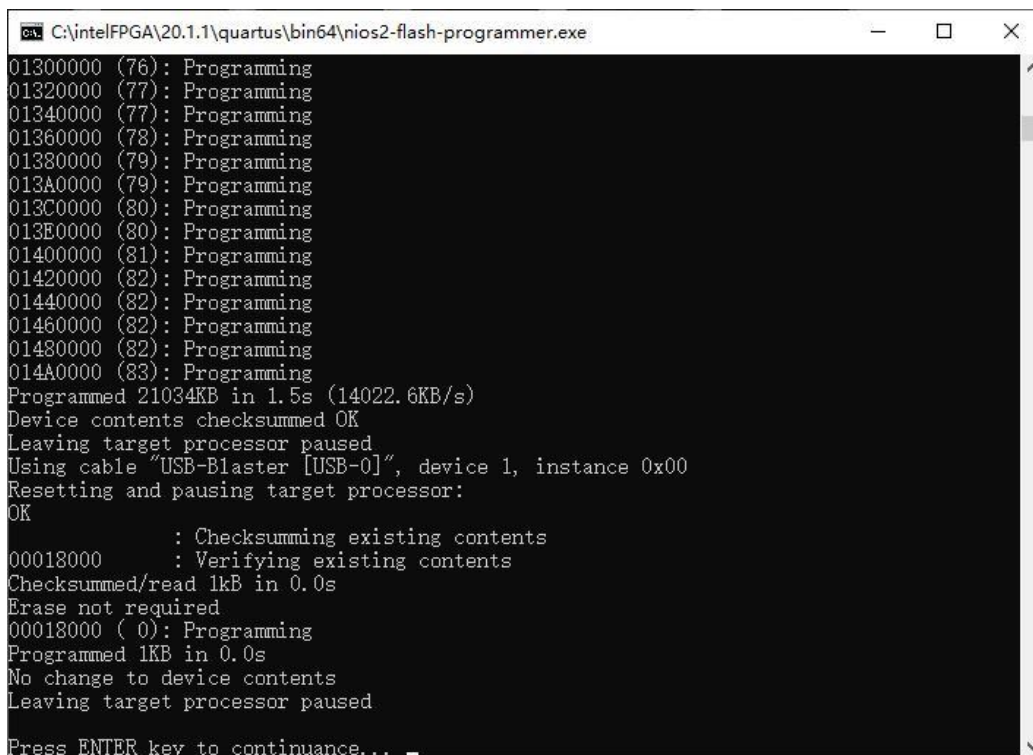

```
C:\intelFPGA\20.1.1\quartus\bin64\nios2-flash-programmer.exe
01300000 (76): Programming
01320000 (77): Programming
01340000 (77): Programming
01360000 (78): Programming
01380000 (79): Programming
013A0000 (79): Programming
013C0000 (80): Programming
013E0000 (80): Programming
01400000 (81): Programming
01420000 (82): Programming
01440000 (82): Programming
01460000 (82): Programming
01480000 (82): Programming
014A0000 (83): Programming
Programmed 21034KB in 1.5s (14022.6KB/s)
Device contents checksummed OK
Leaving target processor paused
Using cable "USB-Blaster [USB-0]", device 1, instance 0x00
Resetting and pausing target processor:
OK
      : Checksumming existing contents
00018000 : Verifying existing contents
Checksummed/read 1kB in 0.0s
Erase not required
00018000 ( 0): Programming
Programmed 1KB in 0.0s
No change to device contents
Leaving target processor paused
Press ENTER key to continuance... _
```

Figure 2-9 Programming Flash complete

2.2 Setup Elements

■ JTAG Control DIP Switch

The TR4 supports individual JTAG interfaces on each HSMC connector. This feature allows users to extend the JTAG chain to daughter cards or additional TR4s. **Before using this interface, JP7 needs to be shorted to enable the JTAG interface on all the HSMC connectors.**

The JTAG signals on each HSMC connector can be removed or included in the active JTAG chain via DIP switches. **Table 2-1** lists the position of the DIP switches and their associated interfaces.

Note that if the JTAG interface on HSMC connector is enabled, make sure that the active JTAG chain must be a closed loop or the FPGA may not be detected. Section 2.5 will give an example on how to extend the JTAG interface to a daughter card. Also, a document named *Using_Mult-TR4_system.pdf* in TR4 system CD shows how to connect the JTAG interface on two stacked TR4 boards.

Table 2-1 JTAG Control

<i>Components</i>	<i>Name</i>	<i>Description</i>	<i>Default</i>
SW4	position 1	HSMCA_TOP ON: HSMA TOP in-chain OFF: Bypass HSMA TOP	OFF
	position 2	HSMCB_TOP ON: HSMB TOP in-chain OFF: Bypass HSMB TOP	OFF
	position 3	HSMCC_TOP ON: HSMC TOP in-chain OFF: Bypass HSMC TOP	OFF
	position 4	HSMCD_TOP ON: HSMD TOP in-chain OFF: Bypass HSMD TOP	OFF
SW5	position 1	HSMCA_BOT ON: HSMA BOT in-chain OFF: Bypass HSMA BOT	OFF
	position 2	HSMCB_BOT ON: HSMB BOT in-chain OFF: Bypass HSMB BOT	OFF
	position 3	HSMCC_BOT ON: HSMC BOT in-chain OFF: Bypass HSMC BOT	OFF
	position 4	HSMCD_BOT ON: HSMD BOT in-chain OFF: Bypass HSMD BOT	OFF
SW6	position 1	HSMCE_TOP ON: HSME TOP in-chain OFF: Bypass HSME TOP	OFF
	position 2	HSMCF_TOP ON: HSMF TOP in-chain OFF: Bypass HSMF TOP	OFF

2.3 Status Elements

The TR4 includes status LEDs. Please refer **Table 2-2** for the status of the LED indicator.

Table 2-2 LED Indicators

<i>Board Reference</i>	<i>LED name</i>	<i>Description</i>
D13	HSMC Port E present	These LEDs are lit when HSMC Port A/B/C/D/E/F have a board or cable plugged-in such that pin 160 becomes grounded.
D14	HSMC Port D present	
D15	HSMC Port A present	
D20	HSMC Port C Present	
D27	HSMC Port B Present	
D28	HSMC Port F Present	
D16	USB Blaster Circuit	This LED is lit when the USB blaster circuit transmits or receives data.
D17	MAX_LOAD	This LED is lit when the FPGA is being actively configured.
D18	MAX_ERROR	This LED is lit when the MAX II CPLD EPM2210 System Controller fails to configure the FPGA.
D19	MAX_CONF_DONE	This LED is lit when the FPGA is successfully configured.
D33	19V POWER	This LED is lit after the 19V adapter is plugged in
D1~D12	HSMC VCCIO_LED	These LEDs indicate the I/O standard of the HSMC ports (see Table 2-12)

2.4 General User Input/Output

■ Push-buttons

The TR4 includes six push-buttons that allow you to interact with the Stratix IV GX FPGA. Each of these buttons is debounced using a Schmitt Trigger circuit, as indicated in [Figure 2-10](#). Each

push-button provides a high logic level or a low logic level when it is not pressed or pressed, respectively (active-low). **Table 2-3** lists the board references, signal names and their corresponding Stratix IV GX device pin numbers.

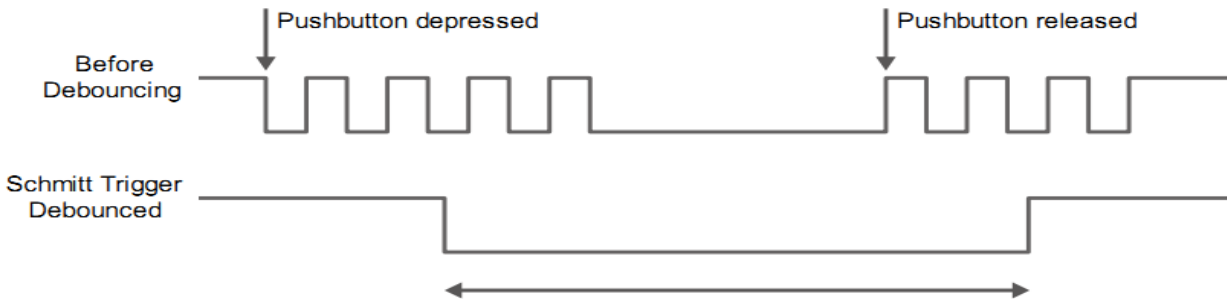

Figure 2-10 Push-button Debouncing

Table 2-3 Push-button Pin Assignments, Schematic Signal Names, and Functions

Name	Locate	Description	I/O Standard	Stratix IV GX Pin Number
PB3	BUTTON3	Low when pushed (Active-low)	1.5V	PIN_P20
PB4	BUTTON2		1.5V	PIN_A19
PB5	BUTTON1		1.5V	PIN_M19
PB6	BUTTON0		1.5V	PIN_L19

The **MAX_RSTN** push-button is used to reset the MAX II EPM2210 CPLD. The **Config** push-button can configure default code to FPGA. **Table 2-4** lists the board references, signal names and their corresponding Stratix IV GX device pin numbers.

Table 2-4 Push-button Pin Assignments, Schematic Signal Names, and Functions

Name	Locate	Description	I/O Standard	EPM2210 Pin Number
PB1	MAX_RSTn	MAX II reset	3.3V-VTTL	PIN_M9
PB2	CONFIG	FPGA reconfig	3.3V-VTTL	PIN_D12

■ Slide Switches

There are four slide switches on the TR4 to provide additional FPGA input control. Each switch is connected directly to a pin of the Stratix IV GX FPGA. When a slide switch is in the DOWN position or the UP position, it provides a low logic level or a high logic level (**VCCIO_HSMF** or **VCCIO_HSMA**) to the FPGA, respectively. **Table 2-5** lists the board references, signal names and

their corresponding Stratix IV GX device pin numbers.

Table 2-5 Slide Switches Pin Assignments, Schematic Signal Names, and Functions

<i>Name</i>	<i>Locate</i>	<i>Description</i>	<i>I/O Standard</i>	<i>Stratix IV GX Pin Number</i>
SW0	SLIDE SW	Provides high logic level when in the UP position	VCCIO_HSMF	PIN_AH18
SW1	SLIDE SW		VCCIO_HSMF	PIN_AH19
SW2	SLIDE SW		VCCIO_HSMA	PIN_D6
SW3	SLIDE SW		VCCIO_HSMA	PIN_C6

■ LEDs

The TR4 consists of 4 user-controllable LEDs to allow status and debugging signals to be driven to the LEDs from the designs loaded into the Stratix IV GX device. Each LED is driven directly by the Stratix IV GX FPGA. The LED is turned on or off when the associated pins are driven to a low or high logic level, respectively (active-low). A list of the pin names on the FPGA that are connected to the LEDs is given in [Table 2-6](#).

Table 2-6 User LEDs Pin Assignments, Schematic Signal Names, and Functions

<i>Name</i>	<i>Description</i>	<i>Description</i>	<i>I/O Standard</i>	<i>Stratix IV GX Pin Number</i>
D27	LED0	LEDs turn on when output is logic low (Active-low)	1.5V	PIN_B19
D28	LED1		1.5V	PIN_A18
D29	LED2		1.5V	PIN_D19
D30	LED3		1.5V	PIN_C19

2.5 High-Speed Mezzanine Cards

The High Speed Mezzanine Card (HSMC) interface provides a mechanism to extend the peripheral-set of an FPGA host board by means of add-on daughter cards, which can address today's high speed signaling requirements as well as low-speed device interface support. The HSMC interfaces support JTAG, clock outputs and inputs, high-speed serial I/O (transceivers), and single-ended or differential signaling. The detailed specifications of the HSMC connectors are described below:

■ 6 HSMC Connector Groups

There are ten HSMC connectors on the TR4 board are divided into 6 groups: HSMC A, HSMC B, HSMC C, HSMC D, HSMC E, and HSMC F. Each group has a male and female HSMC port on the top and bottom side of the TR4 board **except HSMC E and HSMC F**. In addition, both the male and female HSMC connector share the same I/O pins besides JTAG interface and high-speed serial I/O (transceivers).

Caution: DO NOT connect HSMC daughter cards to the backside HSMC (male) connectors. Doing so will permanently damage the on-board FPGA.

■ I/O Distribution

The HSMC connector on the TR4 includes a total of 172 pins, including 121 signal pins (120 signal pins +1 PSNTn pin), 39 power pins, and 12 ground pins. **Figure 2-11** shows the signal bank diagram of HSMC connector. Bank 1 also has dedicated JTAG, I2C bus, and clock signals. The main CMOS/LVDS interface signals, including LVDS/CMOS clocks, are found in banks 2 and 3. Both 12V and 3.3V power pins are also found in banks 2 and 3.

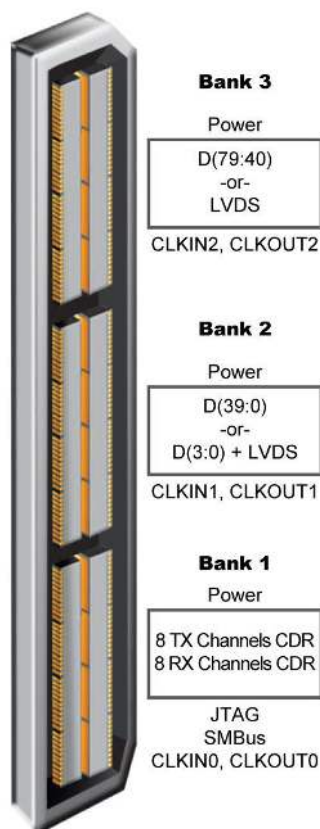

Figure 2-11 HSMC Signal Bank Diagram

Due to the limitation of FPGA bank I/O distribution and dedicated clock in/out pin numbers, there are some differences between individual HSMC connectors, listed below:

■ LVDS Interface

On the TR4 board, only HSMC ports A, B, C and D support LVDS. Each HSMC port provides 18(1) LVDS channel transceivers.

For LVDS transmitters, HSMC ports A and D support 18 true LVDS channels which can run up to 1.6Gbps. The LVDS transmitter on HSMC Port B and C contain true and emulated LVDS channels.

The emulated LVDS channels use two single-ended output buffers and external resistors as shown in **Figure 2-12**. The associated I/O standard of these differential FPGA I/O pins in the Quartus II project should be set to LVDS_E_3R. Emulated LVDS I/O data rates can reach speeds up to 1.1Gbps. The factory default setting for the Rs resistor will be 0 ohm and the Rp resistor will not be assembled for single-ended I/O standard applications. For emulated LVDS transmitters, please solder 120 and 170 ohm resistors onto the Rs and Rp positions, respectively.

For the LVDS receivers, HSMC Port A/B/D support true LVDS receivers which can run at 1.6Gbps. Unlike HSMC ports A/D, not all the LVDS receivers in HSMC ports B/C support On-Chip termination (OCT). To use these I/Os as LVDS receivers, the user needs to solder a 100 ohm resistor for input termination as show in **Figure 2-12**.

Table 2-7 gives the detailed numbers of true and emulated LVDS interfaces of each HSMC port. Also, it lists the numbers of LVDS receivers needed to assemble external input termination resistors on each HSMC ports.

Table 2-8 shows all the external input differential resistors for LVDS receivers on HSMC Port B and C. The factory default setting is not installed.

Finally, because HSMC Port C shares FPGA I/O pins with GPIO headers, so the LVDS performance can only support a data rate of up to 500Mbps.

(1) Although the specifications of the HSMC connector defines signals D0~D3 as single-ended

I/Os, D0 and D2 can be used as LVDS transmitters and D1 and D3 can be used as LVDS receivers on the TR4.

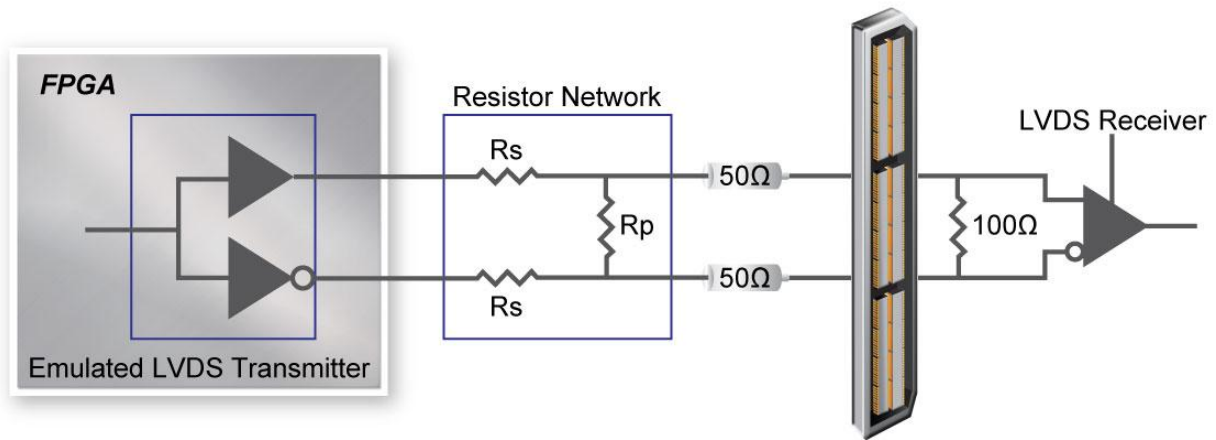

Figure 2-12 Emulated LVDS Resistor Network between FPGA and HSMC Port

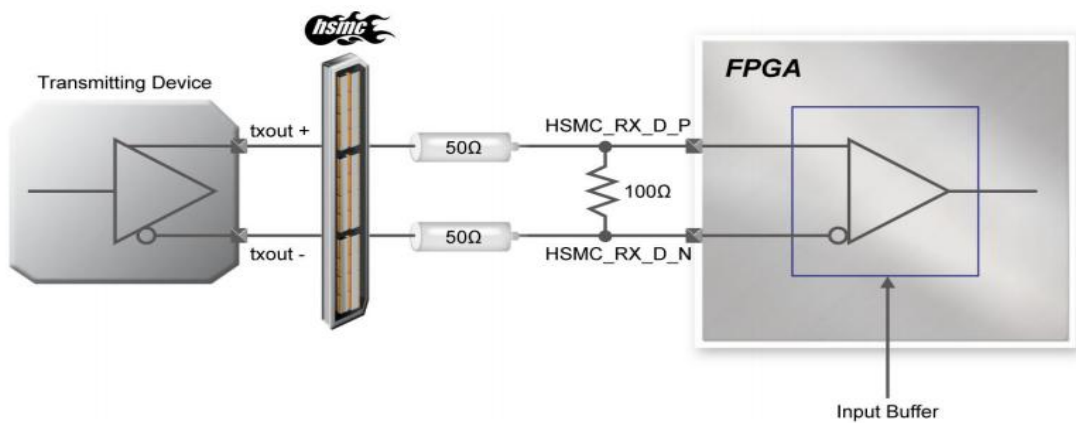

Figure 2-13 External On-Board Termination between FPGA and HSMC Port

Table 2-7 LVDS Breakdown

	<i>HSMA</i>	<i>HSMB</i>	<i>HSMC</i>	<i>HSMD</i>	<i>HSME</i>	<i>HSMF</i>
True LVDS Transmitters	18	10	9	18	9	NA
Emulated LVDS Transmitters	0	8	9	0	NA	NA
Supported with OCT	18	11	9	18	9	NA
Needed External Input Termination Resistors.	0	7	9	0	NA	NA

Table 2-8 Distribution of the Differential Termination Resistors for HSMC Connector

<i>HSMC Differential Net</i>	<i>Reference name of the</i>
------------------------------	------------------------------

	<i>differential termination resistor</i>
HSMB_RX_p[11]	R333
HSMB_RX_p[12]	R318
HSMB_RX_p[13]	R312
HSMB_RX_p[14]	R311
HSMB_RX_p[15]	R303
HSMB_RX_p[16]	R315
HSMB_D[1]	R332
HSMC_RX_p[0]	R314
HSMC_RX_p[1]	R316
HSMC_RX_p[2]	R330
HSMC_RX_p[3]	R341
HSMC_RX_p[4]	R329
HSMC_RX_p[5]	R328
HSMC_RX_p[6]	R309
HSMC_RX_p[7]	R306
HSMC_D[1]	R310

■ High-speed Serial I/O (transceiver) Interface

There are 8 CDR transceiver channels located on the **top side** of HSMC ports A and E, respectively. Each CDR transceiver can run up to 6.5Gbps.

■ Clock Interface

Due to the limitation of the FPGA clock input pin numbers, not all the HSMC ports have same clock interface. **Table 2-9** shows the FPGA clock input pin placement on each HSMC port.

In addition, since FPGA dedicated clock input pins (CLK[1,3,8,10]), or corner PLL clocks don't support On-Chip differential termination, please solder input termination resistors on R299 and R300, respectively, when using HSMC_CLKIN_p2/n2 and HSMA_CLKIN_p2/n2 as LVDS signals.

Table 2-9 HSMC clock interface distribution

<i>HSMC Clock in/out pin name</i>	<i>FPGA Clock Input Pin Placement</i>					
	<i>HSMA</i>	<i>HSMB</i>	<i>HSMC</i>	<i>HSMD</i>	<i>HSME</i>	<i>HSMF</i>

CLKIN0	I/O	I/O	I/O	CLK1n	I/O	CLK5p
CLKIN_p1	CLK9p	I/O	CLK2p	CLK0p	CLK11p	CLK6p
CLKIN_n1	CLK9n	I/O	CLK2n	CLK0n	CLK11n	CLK6n
CLKIN_p2	CLK8p	I/O	CLK3p	I/O	CLK10p	CLK4p
CLKIN_n2	CLK8n	I/O	CLK3n	I/O	CLK10n	CLK4n

■ I2C Interface

The I2C bus on the HSMC connectors is separated into two groups. HSMC Port A, B, and C share the same I2C interface. HSMC ports D, E, and F share the other I2C bus. **Table 2-10** lists the detailed distribution.

Table 2-10 HSMC I2C Group

<i>HSMC A/B/C I2C</i>			
<i>Schematic Signal Name</i>	<i>Description</i>	<i>I/O Standard</i>	<i>Stratix IV GX Pin Number</i>
HSMB_SCL	<i>HSMC A/B/C I2C clock signal</i>	2.5 V (1)	AE16
HSMB_SDA	<i>HSMC A/B/C I2C data signal</i>	2.5 V(1)	AF16
<i>HSMC D/E/F I2C</i>			
<i>Schematic Signal Name</i>	<i>Description</i>	<i>I/O Standard</i>	<i>Stratix IV GX Pin Number</i>
HSMD_SCL	<i>HSMC D/E/F I2C clock signal</i>	1.5V(1)	G21
HSMD_SDA	<i>HSMC D/E/F I2C data signal</i>	1.5V(1)	F21

(1) The I2C I/O on the TR4 HSMC connector is defined with 3.3V.

There is a level translator between FPGA and HSMC connector to translate FPGA 2.5V or 1.5V I/O to 3.3V. The signals above are also connected to the level translator. When these signals are used as general purpose I/O, the maximum data rate is 60Mbps.

■ I/O through the Level Translator

There is a pin named **HSMD_OUT0** on HSMC Port D which is connected to an FPGA 1.5V I/O standard bank. To meet the I/O standard of adjustable specification, a level translator is used between the FPGA and HSMC Port D on this net. Thus, the maximum data rate of this pin is 60Mbps due to the limitations of the level translator.

■ HSMC Port C Shared Bus with GPIO

The HSMC Port C shares the same FPGA I/O pins with the GPIO expansion headers (JP9, JP10). Hence none of the combinations above are allowed to be used simultaneously.

■ Power Supply

The TR4 board provides 12V DC and 3.3V DC power through HSMC ports. **Table 2-11** indicates the maximum power consumption for all HSMC ports. Please note that this table shows the total max current limit for all six ports, not just for one.

Also, the 12V DC and 3.3V DC power supplies from the HSMC ports have fuses for protection. Users who don't need the power from the HSMC can remove these fuses to cut the power on connector.

CAUTION. Before powering on the TR4 board with a daughter card, please check to see if there is a short circuit between the power pins and FPGA I/O.

Table 2-11 Power Supply of the HSMC

<i>Supplied Voltage</i>	<i>Max. Current Limit</i>
12V	2A
3.3V	3A

■ Adjustable I/O Standards

The FPGA I/O standards of the HSMC ports can be adjusted by configuring the header position. Each port can be individually adjusted to 1.5V, 1.8V, 2.5V or 3.0V via jumpers on the top-right corner of TR4 board. **Figure 2-14** depicts the position of the jumpers and their associated I/O standards. Users can use 2-pin jumpers to configure the I/O standard by choosing the associated positions on the header.

Finally, there are LEDs on the top-right corner of TR4 board to indicate the I/O standard of each HSMC port, as shown in **Table 2-12**. For example, LEDs D11 and D12 will be turned on and off, respectively, when the I/O Standard of HSMC Port A is set to 2.5V.

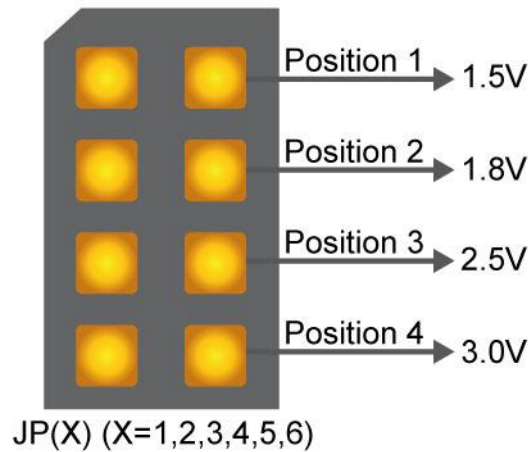

Figure 2-14 HSMC I/O Configuration Header

Table 2-12 HSMC IO Standard Indicators

	HSMA		HSMB		HSMC		HSMD		HSME		HSMF	
	D11	D12	D9	D10	D7	D8	D5	D6	D3	D4	D1	D2
1.5V	OFF	OFF	OFF	OFF	OFF	OFF	OFF	OFF	OFF	OFF	OFF	OFF
1.8V	OFF	ON	OFF	ON	OFF	ON	OFF	ON	OFF	ON	OFF	ON
2.5V	ON	OFF	ON	OFF	ON	OFF	ON	OFF	ON	OFF	ON	OFF
3.0V	ON	ON	ON	ON	ON	ON	ON	ON	ON	ON	ON	ON

(1) Users who connect a daughter card onto the HSMC ports need to pay close attention to the I/O standard between TR4 HSMC connector pins and daughter card system. For example, if the I/O standard of HSMC pins on TR4 board is set to 1.8V, a daughter card with 3.3V or 2.5V I/O standard may not work properly on TR4 board due to I/O standard mismatch. When using custom or third-party HSMC daughter cards, make sure that all the pin locations are aligned to prevent shorts.

■ Using THCB-HMF2 Adapter Card

The purpose of the HSMC Height Extension Male to Female card (THCB-HMF2) included in the

TR4 kit package is to increase the height of the HSMC (Port C and D) connector to avoid any obstruction that might take place as a HSMC daughter card is connected. The THCB-HMF2 adapter card can be connected to either ports of the HSMC connector shown in **Figure 2-15**. There are numerous adapter cards that are supported by the TR4, such as loopback and differential transmission adapters. For more detailed information about these adapter cards, please refer to *HSMC_adapter_card.pdf* which can be found in TR4 system CD.

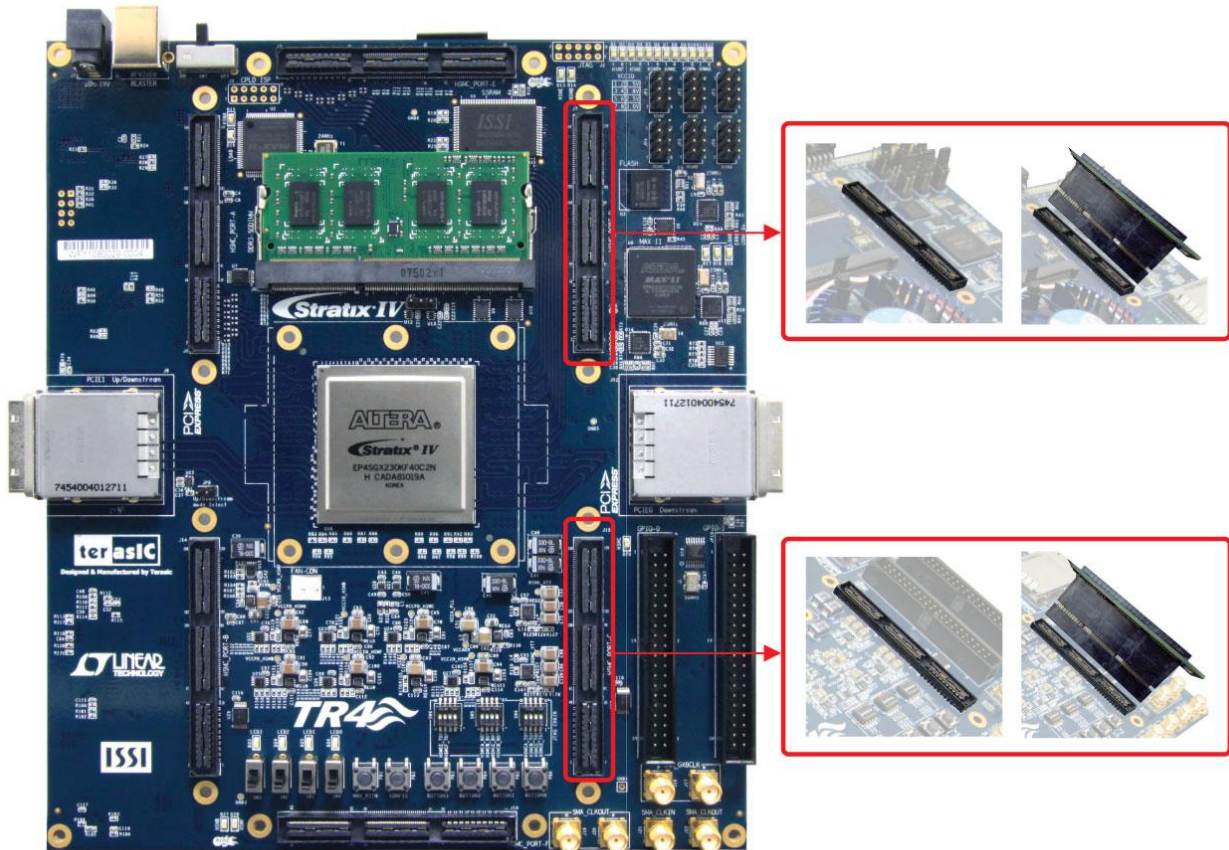

Figure 2-15 Connection between HMF2 Adapter Card and HSMC

■ JTAG Chain on HSMC

The JTAG chain on the HSMC can be activated through the three 4-position DIP switches (SW4, SW5, and SW6). **Table 2-1** in section 2.2 gives a detailed description of the positions of the DIP switches and their associated interfaces. The HSMC connectors on the top side of TR4 board are controlled by SW4 and SW6. SW5 is used to control the HSMC JTAG chain on the bottom-side of the TR4. Only when multiple TR4s are stacked should the boards use this switch. A document titled

Using_Multi-TR4_system.pdf in the TR4 system CD will give an example to demonstrate how to set SW5 to connect JTAG chains together for multiple TR4 boards. Finally, before using the JTAG interface on HSMC connector, please short JP7 in order to enable the HSMC JTAG interface.

The following will describe how to configure the JTAG interface of HSMC connector on the top-side of the TR4.

If there is no connection established on the HSMC connectors, the 4-position DIP switch (SW4 or SW6) should be set to ‘Off’, so the JTAG signals on the HSMC connectors are bypassed illustrated in **Figure 2-16**.

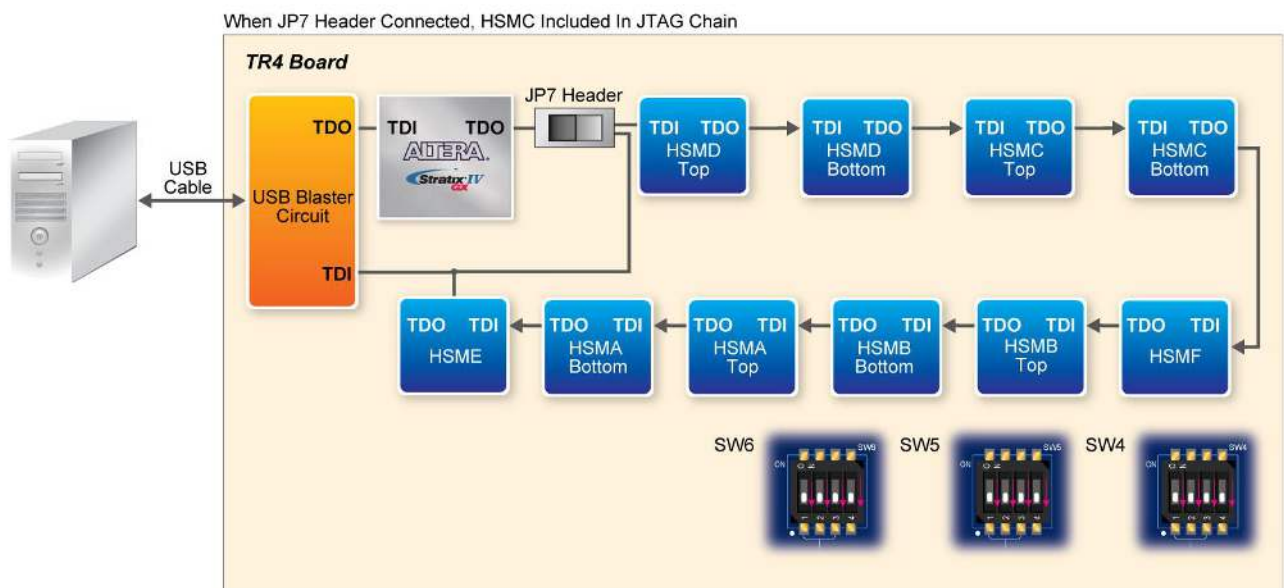

Figure 2-16 JTAG Chain for a Standalone TR4

If the HSMC-based daughter card connected to the HSMC connector uses the JTAG interface, the 4-position DIP switch (SW4 or SW6) should be set to ‘On’ according to the HSMC port used. In this case, from **Figure 2-17** HSMC Port D is used so position 4 of the SW4 switch is set to ‘On’. Similarly, if the JTAG interface isn’t used on the HSMC-based daughter card, position 4 of SW4 is set to ‘Off’, thus bypassing the JTAG signals as shown in **Figure 2-18**.

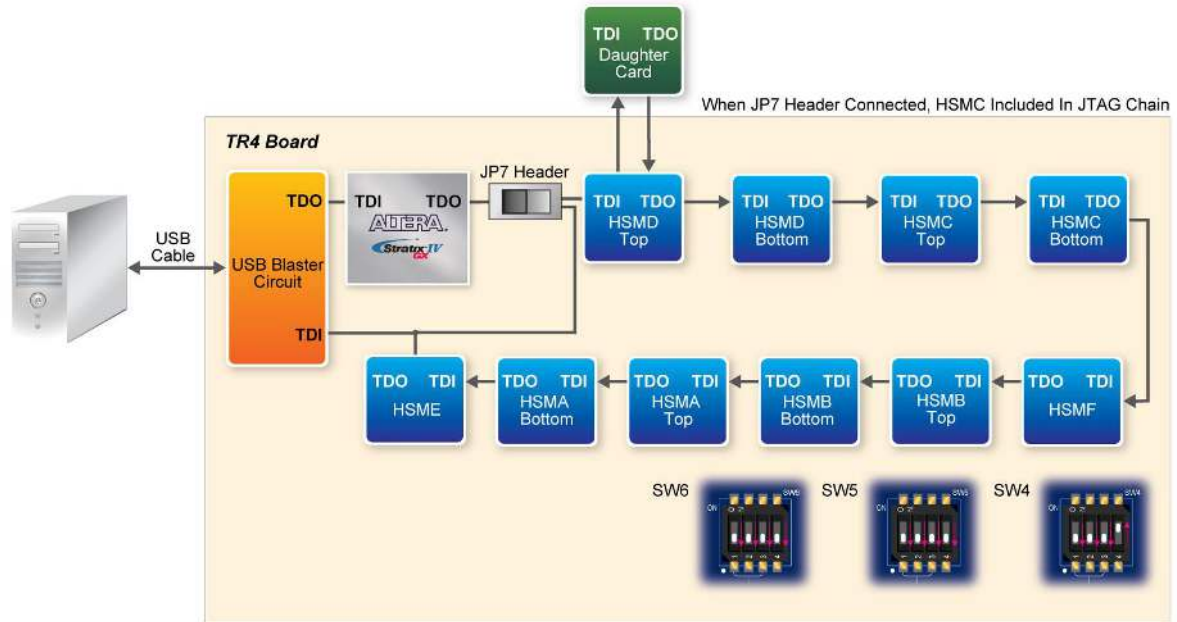

Figure 2-17 JTAG Chain for a Daughter Card (JTAG is used) Connected to HSMC Port D of the TR4

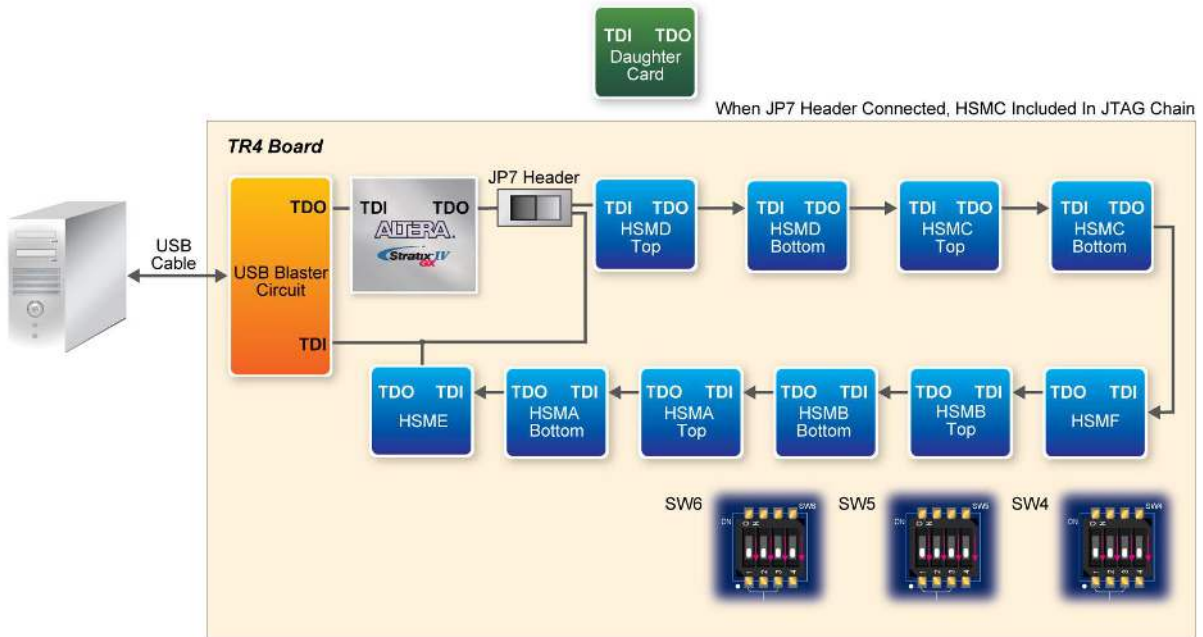

Figure 2-18 JTAG chain for a Daughter Card (JTAG not used) Connected to HSMC Port D of the TR4

■ Multi-FPGA High-Capacity Platforms through HSMC

The TR4 offers a selection of two Stratix IV GX devices, EP4SGX230 and EPSGX530, which offer logic elements (LEs) up to 228,000 and 531,200, respectively, to provide the flexibility for users to select a suitable device. In situations where users' design exceeds the capacity of the FPGA, the HSMC interface can be used to connect to other FPGA system boards creating a multi-FPGA scalable system. Users can stack two TR4s as shown in **Figure 2-19**. Another option is to use a Samtec high-speed cable to connect two TR4 boards (See **Figure 2-20**) to expand your system. For more information on how to use multi-TR4 systems, please refer to *Using_Mult-TR4_system.pdf*, which can be found on the TR4 System CD.

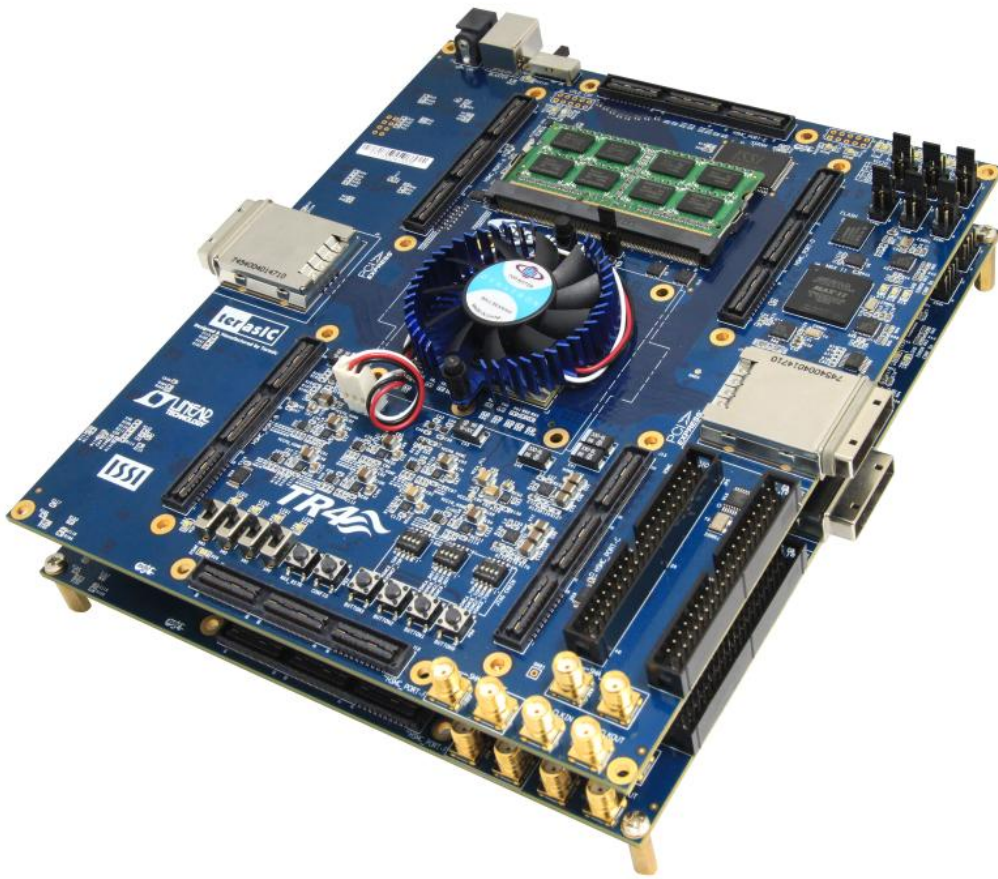

Figure 2-19 Two Stacked TR4 Boards

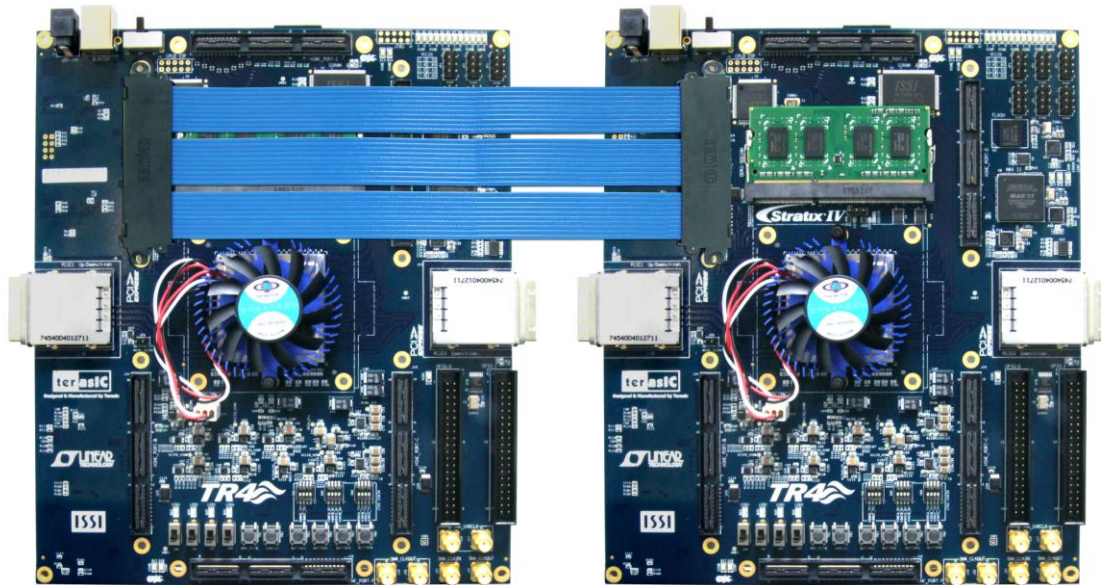

Figure 2-20 Two TR4 Boards Connected via HSMC Cable

2.6 GPIO Expansion Headers

The TR4 consists of two 40-pin expansion headers as shown in **Figure 2-21**. Each header has 36 I/O pins connected to the Stratix IV GX FPGA, with the other 4 pins providing 5V (VCC5) DC, 3.3V (VCC33) DC, and two GND pins.

GPIO 0 and GPIO 1 share pins with HSMC Port C. The I/O standards of the GPIO headers are the same as HSMC Port C, which can be configured between 1.5, 1.8, 2.5 and 3.0V.



Figure 2-21 Pin Distribution of the GPIO Expansion Headers

Finally, **Figure 2-22** shows the connections between the GPIO expansion headers and Stratix IV GX.

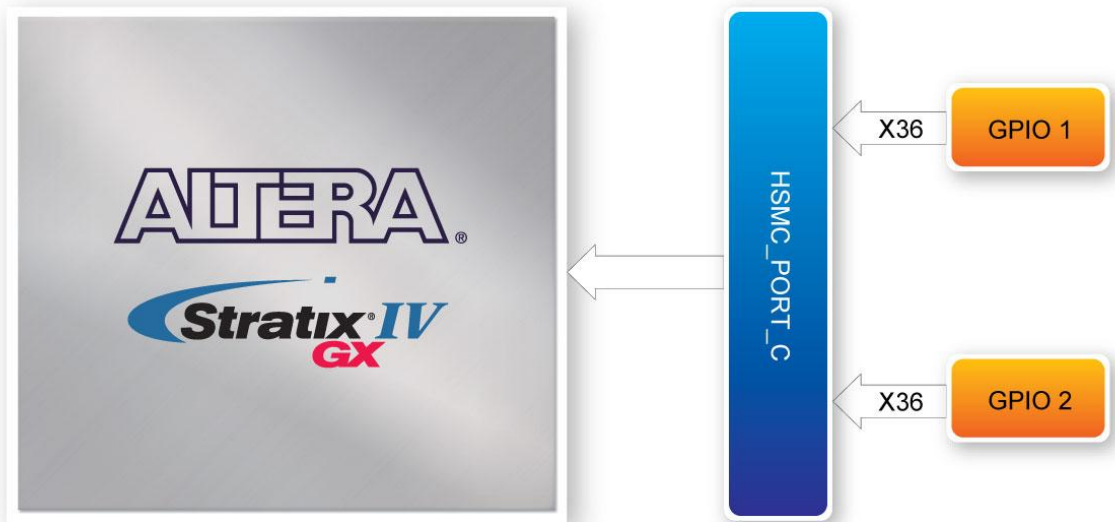

Figure 2-22 Connection between the GPIO Expansion Headers and Stratix IV GX

The information about mapping of the FPGA pin assignments to the GPIO0 and GPIO1 connectors, please refer [Table 2-13](#) and [Table 2-14](#).

Table 2-13 GPIO Expansion Header (JP9) Pin Assignments, Schematic Signal Names, and Functions

Board Reference (JP9)	Schematic Signal Name	Description	I/O Standard	Stratix IV GX Pin Number
1	GPIO0_D0	GPIO Expansion 0 IO[0](Clock In)	Depends on I/O Standard of HSMC Port C	PIN_AF34
2	GPIO0_D1	GPIO Expansion 0 IO[1]		PIN_AG34
3	GPIO0_D2	GPIO Expansion 0 IO[2](Clock In)		PIN_AE35
4	GPIO0_D3	GPIO Expansion 0 IO[3]		PIN_AG35
5	GPIO0_D4	GPIO Expansion 0 IO[4]		PIN_AC31
6	GPIO0_D5	GPIO Expansion 0 IO[5]		PIN_AH32
7	GPIO0_D6	GPIO Expansion 0 IO[6]		PIN_AC32
8	GPIO0_D7	GPIO Expansion 0 IO[7]		PIN_AH33
9	GPIO0_D8	GPIO Expansion 0 IO[8]		PIN_AH34
10	GPIO0_D9	GPIO Expansion 0 IO[9]		PIN_AJ34
13	GPIO0_D10	GPIO Expansion 0 IO[10]		PIN_AH35
14	GPIO0_D11	GPIO Expansion 0 IO[11]		PIN_AJ35
15	GPIO0_D12	GPIO Expansion 0 IO[12]		PIN_AK34
16	GPIO0_D13	GPIO Expansion 0 IO[13]		PIN_AL34
17	GPIO0_D14	GPIO Expansion 0 IO[14]		PIN_AK35
18	GPIO0_D15	GPIO Expansion 0 IO[15]		PIN_AL35
19	GPIO0_D16	GPIO Expansion 0 IO[16]		PIN_AM34

20	GPIO0_D17	GPIO Expansion 0 IO[17]	Depends on I/O Standard of HSMC Port C	PIN_AN34
21	GPIO0_D18	GPIO Expansion 0 IO[18]		PIN_AM35
22	GPIO0_D19	GPIO Expansion 0 IO[19]		PIN_AN35
23	GPIO0_D20	GPIO Expansion 0 IO[20]		PIN_AJ32
24	GPIO0_D21	GPIO Expansion 0 IO[21]		PIN_AJ26
25	GPIO0_D22	GPIO Expansion 0 IO[22]		PIN_AK33
26	GPIO0_D23	GPIO Expansion 0 IO[23]		PIN_AK26
27	GPIO0_D24	GPIO Expansion 0 IO[24]		PIN_AF25
28	GPIO0_D25	GPIO Expansion 0 IO[25]		PIN_AV29
31	GPIO0_D26	GPIO Expansion 0 IO[26]		PIN_AG25
32	GPIO0_D27	GPIO Expansion 0 IO[27]		PIN_AW30
33	GPIO0_D28	GPIO Expansion 0 IO[28]		PIN_AV32
34	GPIO0_D29	GPIO Expansion 0 IO[29]		PIN_AT28
35	GPIO0_D30	GPIO Expansion 0 IO[30]		PIN_AW32
36	GPIO0_D31	GPIO Expansion 0 IO[31]		PIN_AU28
37	GPIO0_D32	GPIO Expansion 0 IO[32]		PIN_AV28
38	GPIO0_D33	GPIO Expansion 0 IO[33]		PIN_AP28
39	GPIO0_D34	GPIO Expansion 0 IO[34]		PIN_AW29
40	GPIO0_D35	GPIO Expansion 0 IO[35]		PIN_AR28

Table 2-14 GPIO Expansion Header (JP10) Pin Assignments, Schematic Signal Names, and Functions

<i>Board Reference (JP10)</i>	<i>Schematic Signal Name</i>	<i>Description</i>	<i>I/O Standard</i>	<i>Stratix IV GX Pin Number</i>
1	GPIO1_D0	GPIO Expansion 1 IO[0]	Depends on I/O Standard of HSMC Port C	PIN_AB27
2	GPIO1_D1	GPIO Expansion 1 IO[1]		PIN_AE25
3	GPIO1_D2	GPIO Expansion 1 IO[2]		PIN_AB28
4	GPIO1_D3	GPIO Expansion 1 IO[3]		PIN_AD25
5	GPIO1_D4	GPIO Expansion 1 IO[4]		PIN_AP27
6	GPIO1_D5	GPIO Expansion 1 IO[5]		PIN_AU29
7	GPIO1_D6	GPIO Expansion 1 IO[6]		PIN_AN27
8	GPIO1_D7	GPIO Expansion 1 IO[7]		PIN_AT29
9	GPIO1_D8	GPIO Expansion 1 IO[8]		PIN_AL25
10	GPIO1_D9	GPIO Expansion 1 IO[9]		PIN_AW33
13	GPIO1_D10	GPIO Expansion 1 IO[10]		PIN_AP26
14	GPIO1_D11	GPIO Expansion 1 IO[11]		PIN_AW34
15	GPIO1_D12	GPIO Expansion 1 IO[12]		PIN_AW31
16	GPIO1_D13	GPIO Expansion 1 IO[13]		PIN_AH24
17	GPIO1_D14	GPIO Expansion 1 IO[14]		PIN_AV31
18	GPIO1_D15	GPIO Expansion 1 IO[15]		PIN_AG24
19	GPIO1_D16	GPIO Expansion 1 IO[16]		PIN_AL27
20	GPIO1_D17	GPIO Expansion 1 IO[17]		PIN_AW27

21	GPIO1_D18	GPIO Expansion 1 IO[18]	Depends on I/O Standard of HSMC Port C	PIN_AH26
22	GPIO1_D19	GPIO Expansion 1 IO[19]		PIN_AW28
23	GPIO1_D20	GPIO Expansion 1 IO[20]		PIN_AK27
24	GPIO1_D21	GPIO Expansion 1 IO[21]		PIN_AD30
25	GPIO1_D22	GPIO Expansion 1 IO[22]		PIN_AE24
26	GPIO1_D23	GPIO Expansion 1 IO[23]		PIN_AD31
27	GPIO1_D24	GPIO Expansion 1 IO[24]		PIN_AB30
28	GPIO1_D25	GPIO Expansion 1 IO[25]		PIN_AE30
31	GPIO1_D26	GPIO Expansion 1 IO[26]		PIN_AB31
32	GPIO1_D27	GPIO Expansion 1 IO[27]		PIN_AE31
33	GPIO1_D28	GPIO Expansion 1 IO[28]		PIN_AG31
34	GPIO1_D29	GPIO Expansion 1 IO[29]		PIN_AE28
35	GPIO1_D30	GPIO Expansion 1 IO[30]		PIN_AG32
36	GPIO1_D31	GPIO Expansion 1 IO[31]		PIN_AE29
37	GPIO1_D32	GPIO Expansion 1 IO[32]		PIN_AF29
38	GPIO1_D33	GPIO Expansion 1 IO[33]		PIN_AD28
39	GPIO1_D34	GPIO Expansion 1 IO[34]		PIN_AG30
40	GPIO1_D35	GPIO Expansion 1 IO[35]		PIN_AD29

2.7 DDR3 SO-DIMM

One DDR3 SO-DIMM socket is provided as a flexible and efficient form-factor volatile memory for user applications. The DDR3 SODIMM socket is wired to support a maximum capacity of 8GB with a 64-bit data bus. Using differential DQS signaling for the DDR3 SDRAM interfaces, it is capable of running at up to 533MHz memory clock for a maximum theoretical bandwidth up to 68Gbps. **Figure 2-23** shows the connections between the DDR3 SO-DIMM socket and Stratix IV GX device. The information about mapping of the FPGA pin assignments to the DDR3 SODIMM connectors, please refer to **Table 2-15**.

Table 2-15 DDR3 SODIMM Pin Assignments, Schematic Signal Names, and Functions

Schematic Signal Name	Description	I/O Standard	Stratix IV GX Pin Number
mem_addr [0]	DDR3 ADDRess [0]	SSTL-15 Class I	PIN_N23
mem_addr [1]	DDR3 ADDRess [1]	SSTL-15 Class I	PIN_C22
mem_addr [2]	DDR3 ADDRess [2]	SSTL-15 Class I	PIN_M22
mem_addr [3]	DDR3 ADDRess [3]	SSTL-15 Class I	PIN_D21
mem_addr [4]	DDR3 ADDRess [4]	SSTL-15 Class I	PIN_P24
mem_addr [5]	DDR3 ADDRess [5]	SSTL-15 Class I	PIN_A24

mem_addr [6]	DDR3 ADDRess [6]	SSTL-15 Class I	PIN_M21
mem_addr [7]	DDR3 ADDRess [7]	SSTL-15 Class I	PIN_D17
mem_addr [8]	DDR3 ADDRess [8]	SSTL-15 Class I	PIN_A25
mem_addr [9]	DDR3 ADDRess [9]	SSTL-15 Class I	PIN_N25
mem_addr [10]	DDR3 ADDRess [10]	SSTL-15 Class I	PIN_C24
mem_addr [11]	DDR3 ADDRess [11]	SSTL-15 Class I	PIN_N21
mem_addr [12]	DDR3 ADDRess [12]	SSTL-15 Class I	PIN_M25
mem_addr [13]	DDR3 ADDRess [13]	SSTL-15 Class I	PIN_K26
mem_addr [14]	DDR3 ADDRess [14]	SSTL-15 Class I	PIN_F16
mem_addr [15]	DDR3 ADDRess [15]	SSTL-15 Class I	PIN_R20
mem_ba[0]	DDR3 Bank ADDRess [0]	SSTL-15 Class I	PIN_B26
mem_ba[1]	DDR3 Bank ADDRess [1]	SSTL-15 Class I	PIN_A29
mem_ba[2]	DDR3 Bank ADDRess [2]	SSTL-15 Class I	PIN_R24
mem_cas_n	DDR3 Column ADDRess Strobe	SSTL-15 Class I	PIN_L26
mem_cke[0]	Clock Enable pin 0 for DDR3	SSTL-15 Class I	PIN_P25
mem_cke[1]	Clock Enable pin 1 for DDR3	SSTL-15 Class I	PIN_M16
mem_ck[0]	Clock p0 for DDR3	Differential 1.5-V SSTL Class I	PIN_K27
mem_ck[1]	Clock p1 for DDR3	Differential 1.5-V SSTL Class I	PIN_L25
mem_ck_n[0]	Clock n0 for DDR3	Differential 1.5-V SSTL Class I	PIN_J27
mem_ck_n[1]	Clock n1 for DDR3	Differential 1.5-V SSTL Class I	PIN_K28
mem_cs_n[0]	DDR3 Chip Select [0]	SSTL-15 Class I	PIN_D23
mem_cs_n[1]	DDR3 Chip Select [1]	SSTL-15 Class I	PIN_G28
mem_dm[0]	DDR3 Data Mask [0]	SSTL-15 Class I	PIN_G16
mem_dm[1]	DDR3 Data Mask [1]	SSTL-15 Class I	PIN_N16
mem_dm[2]	DDR3 Data Mask [2]	SSTL-15 Class I	PIN_P23
mem_dm[3]	DDR3 Data Mask [3]	SSTL-15 Class I	PIN_B29
mem_dm[4]	DDR3 Data Mask [4]	SSTL-15 Class I	PIN_H28
mem_dm[5]	DDR3 Data Mask [5]	SSTL-15 Class I	PIN_E17
mem_dm[6]	DDR3 Data Mask [6]	SSTL-15 Class I	PIN_C26
mem_dm[7]	DDR3 Data Mask [7]	SSTL-15 Class I	PIN_E23
mem_dq[0]	DDR3 Data [0]	SSTL-15 Class I	PIN_G15
mem_dq[1]	DDR3 Data [1]	SSTL-15 Class I	PIN_F15
mem_dq[2]	DDR3 Data [2]	SSTL-15 Class I	PIN_C16
mem_dq[3]	DDR3 Data [3]	SSTL-15 Class I	PIN_B16

mem_dq[4]	DDR3 Data [4]	SSTL-15 Class I	PIN_G17
mem_dq[5]	DDR3 Data [5]	SSTL-15 Class I	PIN_A16
mem_dq[6]	DDR3 Data [6]	SSTL-15 Class I	PIN_D16
mem_dq[7]	DDR3 Data [7]	SSTL-15 Class I	PIN_E16
mem_dq[8]	DDR3 Data [8]	SSTL-15 Class I	PIN_N17
mem_dq[9]	DDR3 Data [9]	SSTL-15 Class I	PIN_M17
mem_dq[10]	DDR3 Data [10]	SSTL-15 Class I	PIN_K17
mem_dq[11]	DDR3 Data [11]	SSTL-15 Class I	PIN_L16
mem_dq[12]	DDR3 Data [12]	SSTL-15 Class I	PIN_P16
mem_dq[13]	DDR3 Data [13]	SSTL-15 Class I	PIN_P17
mem_dq[14]	DDR3 Data [14]	SSTL-15 Class I	PIN_J17
mem_dq[15]	DDR3 Data [15]	SSTL-15 Class I	PIN_H17
mem_dq[16]	DDR3 Data [16]	SSTL-15 Class I	PIN_N22
mem_dq[17]	DDR3 Data [17]	SSTL-15 Class I	PIN_M23
mem_dq[18]	DDR3 Data [18]	SSTL-15 Class I	PIN_J25
mem_dq[19]	DDR3 Data [19]	SSTL-15 Class I	PIN_M24
mem_dq[20]	DDR3 Data [20]	SSTL-15 Class I	PIN_R22
mem_dq[21]	DDR3 Data [21]	SSTL-15 Class I	PIN_P22
mem_dq[22]	DDR3 Data [22]	SSTL-15 Class I	PIN_K24
mem_dq[23]	DDR3 Data [23]	SSTL-15 Class I	PIN_J24
mem_dq[24]	DDR3 Data [24]	SSTL-15 Class I	PIN_A27
mem_dq[25]	DDR3 Data [25]	SSTL-15 Class I	PIN_A28
mem_dq[26]	DDR3 Data [26]	SSTL-15 Class I	PIN_C29
mem_dq[27]	DDR3 Data [27]	SSTL-15 Class I	PIN_C30
mem_dq[28]	DDR3 Data [28]	SSTL-15 Class I	PIN_C27
mem_dq[29]	DDR3 Data [29]	SSTL-15 Class I	PIN_D27
mem_dq[30]	DDR3 Data [30]	SSTL-15 Class I	PIN_A31
mem_dq[31]	DDR3 Data [31]	SSTL-15 Class I	PIN_B31
mem_dq[32]	DDR3 Data [32]	SSTL-15 Class I	PIN_G27
mem_dq[33]	DDR3 Data [33]	SSTL-15 Class I	PIN_G29
mem_dq[34]	DDR3 Data [34]	SSTL-15 Class I	PIN_F28
mem_dq[35]	DDR3 Data [35]	SSTL-15 Class I	PIN_F27
mem_dq[36]	DDR3 Data [36]	SSTL-15 Class I	PIN_E28
mem_dq[37]	DDR3 Data [37]	SSTL-15 Class I	PIN_D28
mem_dq[38]	DDR3 Data [38]	SSTL-15 Class I	PIN_H26

mem_dq[39]	DDR3 Data [39]	SSTL-15 Class I	PIN_J26
mem_dq[40]	DDR3 Data [40]	SSTL-15 Class I	PIN_F19
mem_dq[41]	DDR3 Data [41]	SSTL-15 Class I	PIN_G19
mem_dq[42]	DDR3 Data [42]	SSTL-15 Class I	PIN_F20
mem_dq[43]	DDR3 Data [43]	SSTL-15 Class I	PIN_G20
mem_dq[44]	DDR3 Data [44]	SSTL-15 Class I	PIN_C17
mem_dq[45]	DDR3 Data [45]	SSTL-15 Class I	PIN_F17
mem_dq[46]	DDR3 Data [46]	SSTL-15 Class I	PIN_C18
mem_dq[47]	DDR3 Data [47]	SSTL-15 Class I	PIN_D18
mem_dq[48]	DDR3 Data [48]	SSTL-15 Class I	PIN_D25
mem_dq[49]	DDR3 Data [49]	SSTL-15 Class I	PIN_C25
mem_dq[50]	DDR3 Data [50]	SSTL-15 Class I	PIN_G24
mem_dq[51]	DDR3 Data [51]	SSTL-15 Class I	PIN_G25
mem_dq[52]	DDR3 Data [52]	SSTL-15 Class I	PIN_B25
mem_dq[53]	DDR3 Data [53]	SSTL-15 Class I	PIN_A26
mem_dq[54]	DDR3 Data [54]	SSTL-15 Class I	PIN_D26
mem_dq[55]	DDR3 Data [55]	SSTL-15 Class I	PIN_F24
mem_dq[56]	DDR3 Data [56]	SSTL-15 Class I	PIN_F23
mem_dq[57]	DDR3 Data [57]	SSTL-15 Class I	PIN_G23
mem_dq[58]	DDR3 Data [58]	SSTL-15 Class I	PIN_J22
mem_dq[59]	DDR3 Data [59]	SSTL-15 Class I	PIN_H22
mem_dq[60]	DDR3 Data [60]	SSTL-15 Class I	PIN_K22
mem_dq[61]	DDR3 Data [61]	SSTL-15 Class I	PIN_D22
mem_dq[62]	DDR3 Data [62]	SSTL-15 Class I	PIN_G22
mem_dq[63]	DDR3 Data [63]	SSTL-15 Class I	PIN_E22
mem_dqs[0]	DDR3 Data Strobe p[0]	Differential 1.5-V SSTL Class I	PIN_D15
mem_dqs[1]	DDR3 Data Strobe p[1]	Differential 1.5-V SSTL Class I	PIN_K16
mem_dqs[2]	DDR3 Data Strobe p[2]	Differential 1.5-V SSTL Class I	PIN_L23
mem_dqs[3]	DDR3 Data Strobe p[3]	Differential 1.5-V SSTL Class I	PIN_C28
mem_dqs[4]	DDR3 Data Strobe p[4]	Differential 1.5-V SSTL Class I	PIN_E29
mem_dqs[5]	DDR3 Data Strobe p[5]	Differential 1.5-V SSTL Class I	PIN_G18
mem_dqs[6]	DDR3 Data Strobe p[6]	Differential 1.5-V SSTL Class I	PIN_F25
mem_dqs[7]	DDR3 Data Strobe p[7]	Differential 1.5-V SSTL Class I	PIN_J23
mem_dqs_n[0]	DDR3 Data Strobe n[0]	Differential 1.5-V SSTL Class I	PIN_C15
mem_dqs_n[1]	DDR3 Data Strobe n[1]	Differential 1.5-V SSTL Class I	PIN_J16

mem_dqs_n[2]	DDR3 Data Strobe n[2]	Differential 1.5-V SSTL Class I	PIN_K23
mem_dqs_n[3]	DDR3 Data Strobe n[3]	Differential 1.5-V SSTL Class I	PIN_B28
mem_dqs_n[4]	DDR3 Data Strobe n[4]	Differential 1.5-V SSTL Class I	PIN_D29
mem_dqs_n[5]	DDR3 Data Strobe n[5]	Differential 1.5-V SSTL Class I	PIN_F18
mem_dqs_n[6]	DDR3 Data Strobe n[6]	Differential 1.5-V SSTL Class I	PIN_E25
mem_dqs_n[7]	DDR3 Data Strobe n[7]	Differential 1.5-V SSTL Class I	PIN_H23
mem_odt[0]	DDR3 On-die Termination 0	SSTL-15 Class I	PIN_F26
mem_odt[1]	DDR3 On-die termination 1	SSTL-15 Class I	PIN_G26
mem_ras_n	DDR3 Row ADDRESS Strobe	SSTL-15 Class I	PIN_D24
mem_we_n	DDR3 Write Enable	SSTL-15 Class I	PIN_M27
mem_event_n	DDR3 Temperature Event	SSTL-15 Class I	PIN_R18
mem_reset_n	DDR3 Reset	SSTL-15 Class I	PIN_J18
mem_scl	DDR3 I2C Serial Clock	1.5V	PIN_H19
mem_sda	DDR3 I2C Serial Data Bus	1.5V	PIN_P18

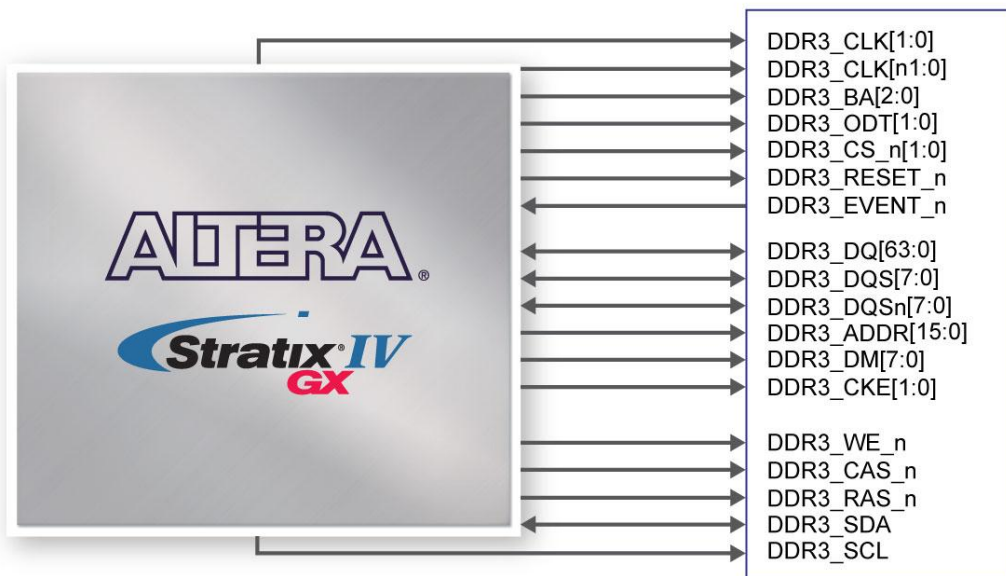

Figure 2-23 Connection between DDR3 and Stratix IV GX FPGA

2.8 Clock Circuitry

■ Stratix IV GX FPGA Clock Inputs and Outputs

The TR4 development board contains three types of clock inputs which include 26 global clock input pins, external PLL clock inputs and transceiver reference clock inputs. The clock input sources of the Stratix IV GX FPGA originate from on-board oscillators, a 50MHz, driven through the clock buffers as well as other interfaces including HSMC, GPIO expansion headers(share pins with HSMC Port C), and SMA connectors. The overall clock distribution of the TR4 is presented in **Figure 2-24**.

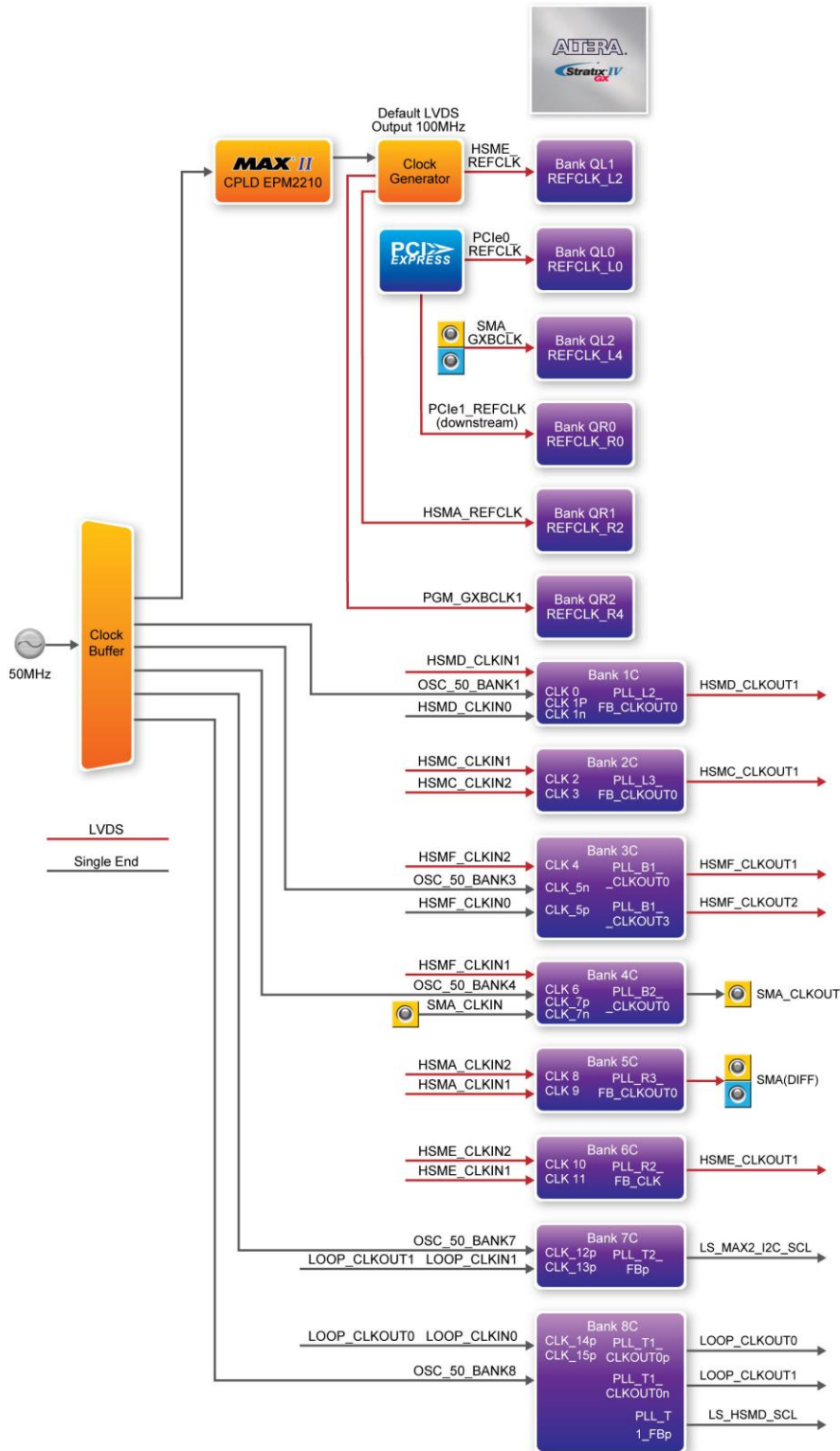

Figure 2-24 Clock Connections of the TR4

Note:

- (1) SMA_CLKOUT_p/N and some HSMC-A clock signals are connected to Bank 5C. If users use SMA_CLKOUT_p/n ,please set HSMC-A I/O standard to 2.5V.
- (2) SMA_GXBCLK_p/n input HSMC-E and PCIE0's Transceiver Bank GXBL.
- (3) PGM_GXBCLK_p1/n1input HSMC-A and PCIE1's Transceiver Bank GXBR.
- (4) HSMD_OUT0 interface through a level shift, so the maximum speed is 60Mbps.

The Stratix IV GX FPGA consists of 8 dedicated clock input pins and from those pins, 3 dedicated differential clock input listed in **Table 2–19**. In addition, there are a total of 8 PLLs available for the Stratix IV GX device.

Table 2–19 Dedicated Clock Input Pins

<i>Dedicated Clock Input Pins</i>
OSC_50_BANK1
HSMD_CLKIN0
HSMC_CLKIN_p2
HSMC_CLKIN_n2
HSMA_CLKIN_p2
HSMA_CLKIN_n2
HSME_CLKIN_p2
HSME_CLKIN_n2

The dedicated clock input pins from the clock input multiplexer allow users to use any of these clocks as a source clock to drive the Stratix IV PLL circuit through the GCLK and RCLK networks. Alternatively, PLLs through the GCLK and RCLK networks or from dedicated connections on adjacent top/bottom and left/right PLLs can also drive the PLL circuit. The clock outputs of the Stratix IV GX FPGA are derived from various interfaces, notably the HSMC and the SMA connectors.

■ Stratix IV GX FPGA Transceiver Clock Inputs

The transceiver reference clock inputs for the serial protocols supported by the Stratix IV GX FPGA transceiver channels include the PCI Express (PIPE) and the SMA connectors.

The TR4 uses three programmable low-jitter clock generators with default clock output of 100MHz and an I/O standard of LVDS that is non-configurable. The clock generators are programmed via Max II CPLD to generate the necessary clocks for the Stratix IV GX transceiver protocols and

interfaces such as HSMC. The PCI Express (PIPE) transceiver reference clock is generated from the PCIe connector.

The clock frequency for the programmable clock generators can be specified by using the TR4 control panel, TR4 system builder, or the external clock generator demo provided.

The associated pin assignments for clock buffer and SMA connectors to FPGA I/O pins are shown in [Table 2–20](#).

Table 2–20 Clock Inputs/Outputs Pin Assignments, Schematic Signal Names, and Functions

<i>Board Reference</i>	<i>Schematic Signal Name</i>	<i>Description</i>	<i>I/O Standard</i>	<i>Stratix IV GX Pin Number</i>
U49-4	OSC_50_BANK1	Dedicated 50MHz clock input for bank 1C	2.5-V	AB34
U21-4	OSC_50_BANK3	50MHz clock input for bank 3C	2.5-V	AW22
U20-4	OSC_50_BANK4	50MHz clock input for bank 4C	2.5-V	AV19
U12-4	OSC_50_BANK7	50MHz clock input for bank 7C	1.5-V	A21
U13-4	OSC_50_BANK8	50MHz clock input for bank 8C	1.5-V	B23
U11-6	HSMA_REFCLK_p	HSMC-A transceiver reference clock input	LVDS	AA2
U11-5	HSMA_REFCLK_n	HSMC-A transceiver reference clock input	LVDS	AA1
U5-6	HSME_REFCLK_p	HSMC-E transceiver reference clock input	LVDS	AA38
U5-5	HSME_REFCLK_n	HSMC-E transceiver reference clock input	LVDS	AA39
J20	SMA_CLKOUT_p	SMA differential clock output	2.5V or LVDS	AC11
J19	SMA_CLKOUT_n	SMA differential clock output	2.5V or LVDS	AC10
J16	SMA_GXBCLK_p	SMA transceiver reference clock input	LVDS	J38
J17	SMA_GXBCLK_n	SMA transceiver reference clock input	LVDS	J39
J21	SMA_CLKIN	SMA clock input	2.5V	AW19

2.9 PCI Express

The TR4 development board features two PCIe Express **downstream** interfaces (x4 lane) which are designed to interface with a PC motherboard x4 slot via PCIe cable and PCIe adapter card. Utilizing built-in transceivers on a Stratix IV GX device, it is able to provide a fully integrated PCI Express-compliant solution for multi-lane (x4) applications. With the PCI Express hard IP block incorporated in the Stratix IV GX device, it will allow users to implement simple and fast protocol, as well as saving logic resources for logic application.

The PCI Express interface supports complete PCI Express Gen1 at 2.5Gbps/lane and Gen2 at 5.0Gbps/lane protocol stack solution compliant to PCI Express base specification 2.0 that includes PHY-MAC, Data Link, and transaction layer circuitry embedded in PCI Express hard IP blocks.

To use PCIe interface, two external associated devices will be needed to establish link with PC. First, a PCIe half-height add-in host card with a PCIe x4 cable connector called PCA (PCIe Cabling Adapter Card)(See [Figure 2-25](#)) will be used to plug into the PCIe slot on a mother board. Then, a PCIe x4 cable (See [Figure 2-26](#)) will be used to connect TR4 board and PCIe add-in card as shown in [Figure 2-27](#), the longest length up to 3 meters. These two associated devices are not included in TR4 kit. To purchase the PCA card as well as the external cable, please reference Terasic website pca.terasic.com and PCIe_Cable.terasic.com.

Finally, section 6.3 and 6.4 demonstrate two examples on how to use the PCIe interface of TR4 board with a PC. [Table 2-16](#) and [Table 2-17](#) summarize the PCI Express pin assignments of the signal names relative to the Stratix IV GX FPGA.

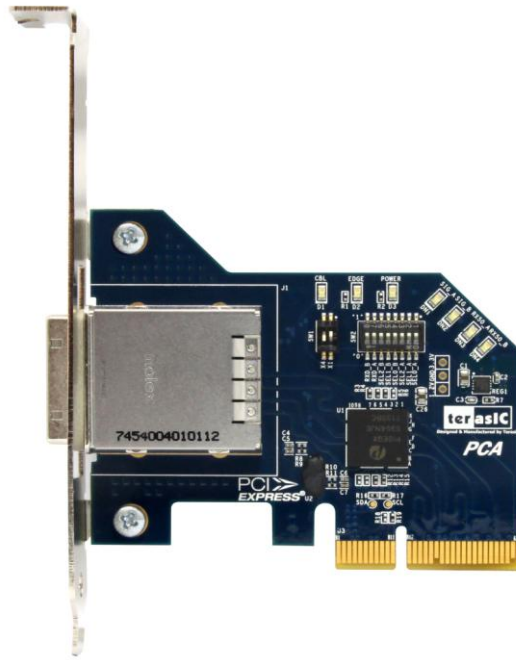

Figure 2-25 PCIe Cabling Adaptor(PCA) card



Figure 2-26 PCIe External Cable

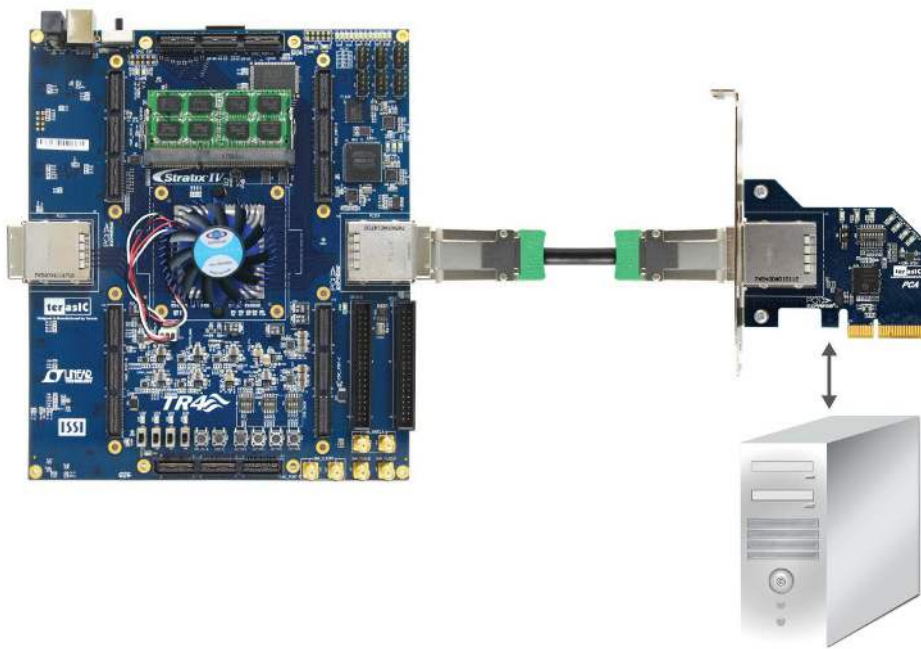

Figure 2-27 PCIe Link Setup between TR4 and PC

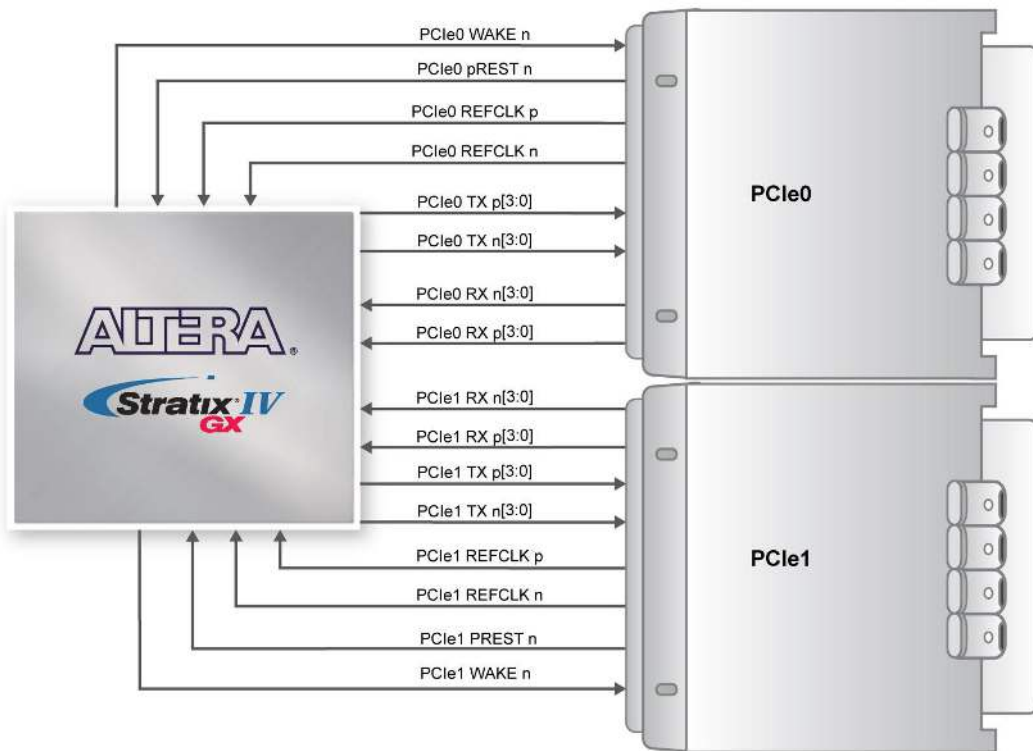

Figure 2-28 PCI Express Pin Connection

Table 2-16 PCIe0 Pin Assignments, Schematic Signal Names, and Functions

<i>PCIe0 4-Lane Downstream</i>			
<i>Name</i>	<i>Description</i>	<i>I/O Standard</i>	<i>Stratix IV GX Pin Number</i>
PCIE0_REFCLK_p	PCIe0 reference clock	HCSL	AN38
PCIE0_PREST_n	PCIe0 present	Depends on HSMC Port A I/O standard	F8
PCIE0_WAKE_n	PCIe0 wake	Depends on HSMC Port A I/O standard	AE10
PCIE0_TX_p[0]	PCIe0 data lane	1.4-V PCML	AT36
PCIE0_RX_p[0]		1.4-V PCML	AU38
PCIE0_TX_p[1]		1.4-V PCML	AP36
PCIE0_RX_p[1]		1.4-V PCML	AR38
PCIE0_TX_p[2]		1.4-V PCML	AH36
PCIE0_RX_p[2]		1.4-V PCML	AJ38
PCIE0_TX_p[3]		1.4-V PCML	AF36
PCIE0_RX_p[3]		1.4-V PCML	AG38

Table 2-17 PCIe1 Express Pin Assignments, Schematic Signal Names, and Functions

<i>PCIe1 4-Lane Downstream</i>			
<i>Name</i>	<i>Description</i>	<i>I/O Standard</i>	<i>Stratix IV GX Pin Number</i>
PCIE1_REFCLK_p	PCIe1 reference clock	HCSL	AN2
PCIE1_PREST_n	PCIe1 present	Depends on HSMC Port A I/O standard	G8
PCIE1_WAKE_n	PCIe1 wake	Depends on HSMC Port A I/O standard	AE11
PCIE1_TX_p[0]	PCIe1 data lane	1.4-V PCML	AT4
PCIE1_RX_p[0]		1.4-V PCML	AU2
PCIE1_TX_p[1]		1.4-V PCML	AP4
PCIE1_RX_p[1]		1.4-V PCML	AR2
PCIE1_TX_p[2]		1.4-V PCML	AH4
PCIE1_RX_p[2]		1.4-V PCML	AJ2
PCIE1_TX_p[3]		1.4-V PCML	AF4
PCIE1_RX_p[3]		input	

2.10 Flash Memory

The TR4 development board features a 64MB Intel CFI-compliant NOR-type flash memory device which is part of the shared FMS Bus consisting of flash memory, SSRAM, and the Max II CPLD

(EPM2210) System Controller. The single synchronous flash memory with 16-bit data bus supports 4-word, 8-word 16-word, and continuous-word burst mode provides non-volatile storage that can be used for configuration as well as software storage. The memory interface can sustain output synchronous-burst read operations at 40MHz with zero wait states. The device defaults to asynchronous page-mode read when power-up is initiated or returned from reset.

This device is also used to store configuration files for the Stratix IV GX FPGA where the MAX II CPLD (EPM2210) can access flash for FPP configuration of the FPGA using the PFL Megafunction. **Table 2-18** lists the flash pin assignments, signal names, and functions.

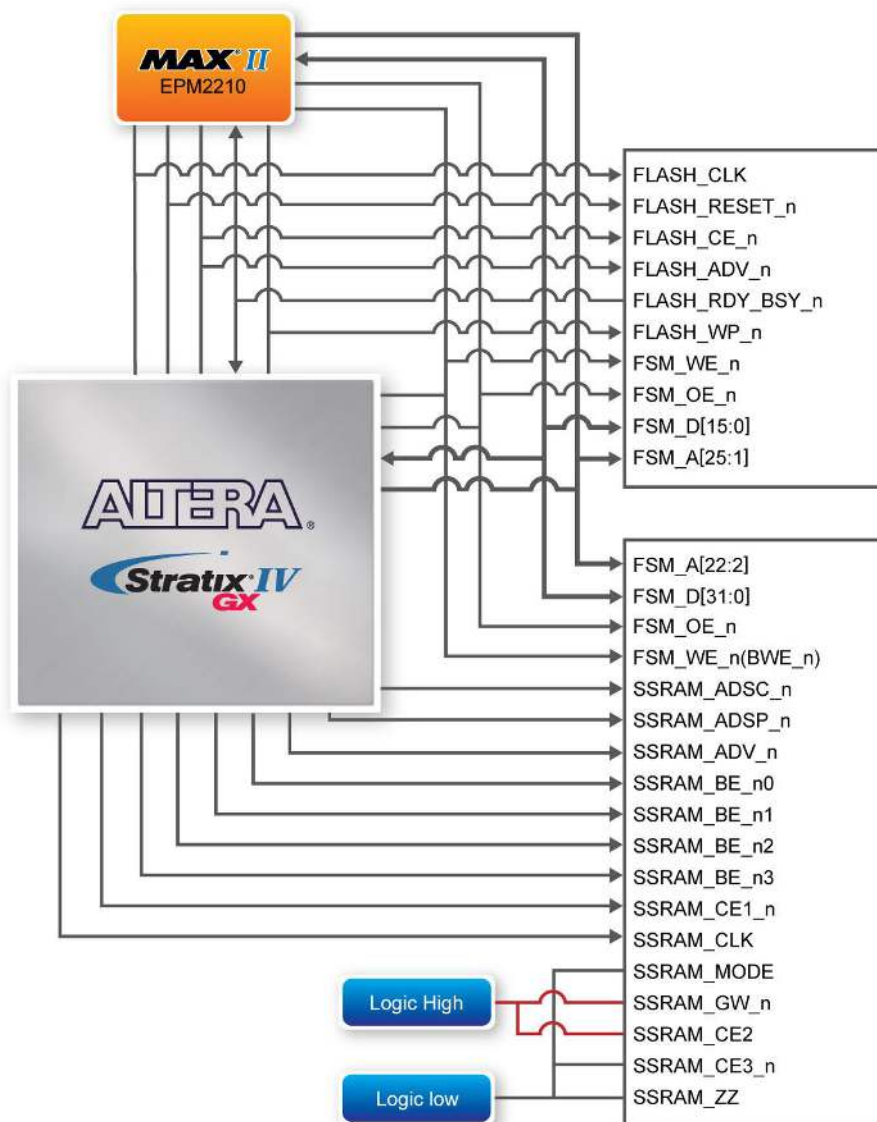

Figure 2-29 Connection between Flash, SSRAM, MAXII EPM2210 and the Stratix IV GX FPGA

Table 2-18 Flash Memory Pin Assignments, Schematic Signal Names, and Functions

<i>Schematic Signal Name</i>	<i>Description</i>	<i>I/O Standard</i>	<i>Stratix IV GX Pin Number</i>
FSM_A1	Address bus	3.0-V PCI-X	PIN_L31
FSM_A2	Address bus	3.0-V PCI-X	PIN_F34
FSM_A3	Address bus	3.0-V PCI-X	PIN_D35
FSM_A4	Address bus	3.0-V PCI-X	PIN_D34
FSM_A5	Address bus	3.0-V PCI-X	PIN_E34
FSM_A6	Address bus	3.0-V PCI-X	PIN_C35
FSM_A7	Address bus	3.0-V PCI-X	PIN_C34
FSM_A8	Address bus	3.0-V PCI-X	PIN_F33
FSM_A9	Address bus	3.0-V PCI-X	PIN_G35
FSM_A10	Address bus	3.0-V PCI-X	PIN_H35
FSM_A11	Address bus	3.0-V PCI-X	PIN_J32
FSM_A12	Address bus	3.0-V PCI-X	PIN_J33
FSM_A13	Address bus	3.0-V PCI-X	PIN_K32
FSM_A14	Address bus	3.0-V PCI-X	PIN_K31
FSM_A15	Address bus	3.0-V PCI-X	PIN_AH17
FSM_A16	Address bus	3.0-V PCI-X	PIN_AH16
FSM_A17	Address bus	3.0-V PCI-X	PIN_AE17
FSM_A18	Address bus	3.0-V PCI-X	PIN_AG16
FSM_A19	Address bus	3.0-V PCI-X	PIN_H32
FSM_A20	Address bus	3.0-V PCI-X	PIN_H34
FSM_A21	Address bus	3.0-V PCI-X	PIN_G33
FSM_A22	Address bus	3.0-V PCI-X	PIN_F35
FSM_A23	Address bus	3.0-V PCI-X	PIN_N31
FSM_A24	Address bus	3.0-V PCI-X	PIN_M31
FSM_A25	Address bus	3.0-V PCI-X	PIN_M30
FSM_D0	Data bus	3.0-V PCI-X	PIN_B32
FSM_D1	Data bus	3.0-V PCI-X	PIN_C32
FSM_D2	Data bus	3.0-V PCI-X	PIN_C31
FSM_D3	Data bus	3.0-V PCI-X	PIN_F32
FSM_D4	Data bus	3.0-V PCI-X	PIN_J30
FSM_D5	Data bus	3.0-V PCI-X	PIN_K29
FSM_D6	Data bus	3.0-V PCI-X	PIN_K30
FSM_D7	Data bus	3.0-V PCI-X	PIN_L29
FSM_D8	Data bus	3.0-V PCI-X	PIN_M29
FSM_D9	Data bus	3.0-V PCI-X	PIN_N29
FSM_D10	Data bus	3.0-V PCI-X	PIN_P29
FSM_D11	Data bus	3.0-V PCI-X	PIN_T27
FSM_D12	Data bus	3.0-V PCI-X	PIN_AM17
FSM_D13	Data bus	3.0-V PCI-X	PIN_AL17
FSM_D14	Data bus	3.0-V PCI-X	PIN_AK16

FSM_D15	Data bus	3.0-V PCI-X	PIN_AJ16
FLASH_CLK	Clock	3.0-V PCI-X	PIN_AU15
FLASH_RESET_n	Reset	3.0-V PCI-X	PIN_AV16
FLASH_CE_n	Chip Enable	3.0-V PCI-X	PIN_AP16
FSM_OE_n	Output Enable	3.0-V PCI-X	PIN_AT16
FSM_WE_n	Write Enable	3.0-V PCI-X	PIN_AL16
FLASH_ADV_n	Address Valid	3.0-V PCI-X	PIN_AT15
FLASH_RDY_BSY_n	Ready	1.5 V	PIN_A23
FLASH_WP_n	Write Protect	1.5 V	PIN_A20

2.11 SSRAM Memory

The Synchronous Static Random Access Memory (SSRAM) device featured on the TR4 development board is part of the shared Flash-SSRAM-Max II (FSM) bus, which connects to Flash memory, SSRAM, and the MAX II CPLD (E2PROM2210) System Controller. This device is a 2MB synchronously pipelined and high-speed, low-power synchronous static RAM designed to provide burstable, high-performance memory for communication and networking applications. **Table 2-19** lists the SSRAM pin assignments and signal names relative to the Stratix IV GX device in terms of I/O setting.

Table 2-19 SSRAM Memory Pin Assignments, Schematic Signal Names, and Functions

<i>Schematic Signal Name</i>	<i>Description</i>	<i>I/O Standard</i>	<i>Stratix IV GX Pin Number</i>
FSM_A2	Address bus A0	3.0-V PCI-X	PIN_F34
FSM_A3	Address bus A1	3.0-V PCI-X	PIN_D35
FSM_A4	Address bus A2	3.0-V PCI-X	PIN_D34
FSM_A5	Address bus A3	3.0-V PCI-X	PIN_E34
FSM_A6	Address bus A4	3.0-V PCI-X	PIN_C35
FSM_A7	Address bus A5	3.0-V PCI-X	PIN_C34
FSM_A8	Address bus A6	3.0-V PCI-X	PIN_F33
FSM_A9	Address bus A7	3.0-V PCI-X	PIN_G35
FSM_A10	Address bus A8	3.0-V PCI-X	PIN_H35
FSM_A11	Address bus A9	3.0-V PCI-X	PIN_J32
FSM_A12	Address bus A10	3.0-V PCI-X	PIN_J33
FSM_A13	Address bus A11	3.0-V PCI-X	PIN_K32
FSM_A14	Address bus A12	3.0-V PCI-X	PIN_K31
FSM_A15	Address bus A13	3.0-V PCI-X	PIN_AH17
FSM_A16	Address bus A14	3.0-V PCI-X	PIN_AH16
FSM_A17	Address bus A15	3.0-V PCI-X	PIN_AE17
FSM_A18	Address bus A16	3.0-V PCI-X	PIN_AG16

FSM_A19	Address bus A17	3.0-V PCI-X	PIN_H32
FSM_A20	Address bus A18	3.0-V PCI-X	PIN_H34
FSM_A21	Address bus A19	3.0-V PCI-X	PIN_G33
FSM_A22	Address bus A20	3.0-V PCI-X	PIN_F35
FSM_D0	Data bus	3.0-V PCI-X	PIN_B32
FSM_D1	Data bus	3.0-V PCI-X	PIN_C32
FSM_D2	Data bus	3.0-V PCI-X	PIN_C31
FSM_D3	Data bus	3.0-V PCI-X	PIN_F32
FSM_D4	Data bus	3.0-V PCI-X	PIN_J30
FSM_D5	Data bus	3.0-V PCI-X	PIN_K29
FSM_D6	Data bus	3.0-V PCI-X	PIN_K30
FSM_D7	Data bus	3.0-V PCI-X	PIN_L29
FSM_D8	Data bus	3.0-V PCI-X	PIN_M29
FSM_D9	Data bus	3.0-V PCI-X	PIN_N29
FSM_D10	Data bus	3.0-V PCI-X	PIN_P29
FSM_D11	Data bus	3.0-V PCI-X	PIN_T27
FSM_D12	Data bus	3.0-V PCI-X	PIN_AM17
FSM_D13	Data bus	3.0-V PCI-X	PIN_AL17
FSM_D14	Data bus	3.0-V PCI-X	PIN_AK16
FSM_D15	Data bus	3.0-V PCI-X	PIN_AJ16
FSM_D16	Data bus	3.0-V PCI-X	PIN_AK17
FSM_D17	Data bus	3.0-V PCI-X	PIN_T28
FSM_D18	Data bus	3.0-V PCI-X	PIN_R27
FSM_D19	Data bus	3.0-V PCI-X	PIN_R28
FSM_D20	Data bus	3.0-V PCI-X	PIN_R29
FSM_D21	Data bus	3.0-V PCI-X	PIN_N30
FSM_D22	Data bus	3.0-V PCI-X	PIN_N28
FSM_D23	Data bus	3.0-V PCI-X	PIN_M28
FSM_D24	Data bus	3.0-V PCI-X	PIN_H31
FSM_D25	Data bus	3.0-V PCI-X	PIN_G31
FSM_D26	Data bus	3.0-V PCI-X	PIN_D31
FSM_D27	Data bus	3.0-V PCI-X	PIN_E31
FSM_D28	Data bus	3.0-V PCI-X	PIN_F31
FSM_D29	Data bus	3.0-V PCI-X	PIN_E32
FSM_D30	Data bus	3.0-V PCI-X	PIN_C33
FSM_D31	Data bus	3.0-V PCI-X	PIN_D33
FSM_OE_n(OE_n)	Output Enable	3.0-V PCI-X	PIN_AT16
FSM_WE_n(BWE_n)	Byte Write Enable	3.0-V PCI-X	PIN_AL16
SSRAM_ADSC_n	Address Status Controller	3.0-V PCI-X	PIN_AP17
SSRAM_ADSP_n	Address Status Processor	3.0-V PCI-X	PIN_AR17
SSRAM_ADV_n	Synchronous Burst Address Advance	3.0-V PCI-X	PIN_AW16
SSRAM_BE_n0	Synchronous Byte Write Controls	3.0-V PCI-X	PIN_AN16
SSRAM_BE_n1	Synchronous Byte Write Controls	3.0-V PCI-X	PIN_AN17
SSRAM_BE_n2	Synchronous Byte Write Controls	3.0-V PCI-X	PIN_AR16
SSRAM_BE_n3	Synchronous Byte Write Controls	3.0-V PCI-X	PIN_AU16

SSRAM_CE1_n	Synchronous Chip Enable	3.0-V PCI-X	PIN_AF17
SSRAM_CLK	Synchronous Clock	3.0-V PCI-X	PIN_AG17
SSRAM_MODE	Burst Sequence Selection	-	-
SSRAM_GW_n	Synchronous Global Write Enable	-	-
SRAM_CE2	Synchronous Chip Enable	-	-
SSRAM_CE3_n	Synchronous Chip Enable	-	-
SSRAM_ZZ	Power Sleep Mode	-	-

2.12 Temperature Sensor and Fan

The TR4 is equipped with a temperature sensor MAX1619, which provides temperature sensing and over-temperature alerts. These functions are accomplished by connecting the temperature sensor to the internal temperature sensing diode of the Stratix IV GX device. The temperature status and alarm threshold registers of the temperature sensor can be programmed by a two-wire SMBus, which is connected to the Stratix IV GX FPGA. The 7-bit power-on-reset (POR) slave address for this sensor is ‘0011000b’.

An optional 3-pin +12V header for fan control located on J10 of the TR4 board is intended to reduce the temperature of the FPGA. When the temperature of the FPGA device is over the threshold value set by the users, the fan will turn on automatically. The pin assignments for the associated interface are listed in [Table 2-20](#).

Table 2-20 Temperature Sensor Pin Assignments, Schematic Signal Names, and Functions

<i>Schematic Signal Name</i>	<i>Description</i>	<i>I/O Standard</i>	<i>Stratix IV GX Pin Number</i>
TEMP_SMCLK	SMBus clock	2.5-V	PIN_AR14
TEMP_SMDAT	SMBus data	2.5-V	PIN_AP14
TEMP_OVERT_n	SMBus over-temperature alarm	2.5-V	PIN_AK14
TEMP_INT_n	SMBus alert (interrupt)	2.5-V	PIN_AH13
FAN_CTRL	Fan control	1.5-V	PIN_B17

2.13 Power

The TR4 board features a standalone DC input rated at 19V. The DC voltage is stepped down to various power rails used by the components on the board and installed into the HSMC connectors.

Power Switch

The slide switch (SW7) is the board power switch for the DC power input. When the slide switch is in the ON position, the board is powered on. Alternatively when the switch is in the OFF position, the board is powered off.

2.14 Security

The TR4 board features design security to protect your designs against unauthorized copying, reverse engineering, and tampering of your configuration files. For more information, please refer to Altera's application note, "AN556: Using the Design Security Features in Altera FPGAs"

2.15 Using External Blaster

User can use external blaster to configure FPGA such us Ethernet Blaster. To use this feature, user need to install 2x5 2.54mm connector and four 0 Ohm resistor (0402 size) on J2 and R199~R201, respectively (See **Figure 2-30** and **Figure 2-31**).

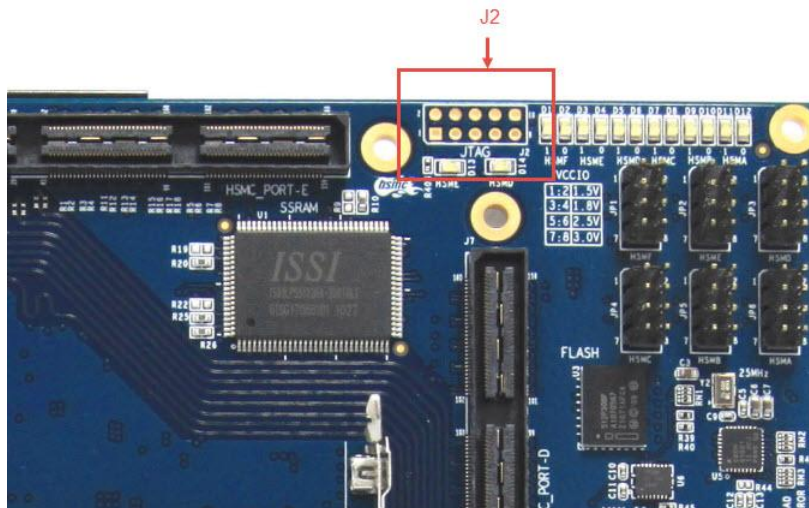

Figure 2-30 J2 Position on TR4

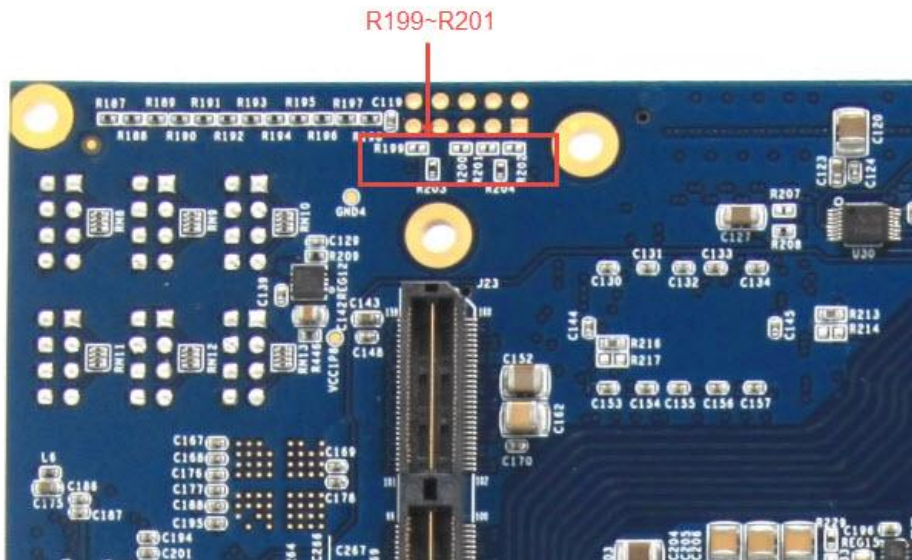

Figure 2-31 R199~R201 Position on TR4

Chapter 3

Control Panel

The TR4 board comes with a PC-based Control Panel that allows users to access various components onboard. The host computer communicates with the board via USB-Blaster port. The tool can be used to verify the functionality of components.

This chapter presents some basic functions of the Control Panel, illustrates its structure in block diagram form, and finally describes its capabilities.

3.1 Control Panel Setup

The Control Panel software utility is located in the directory “/Tools/TR4_ControlPanel” in the **TR4 System CD**. To execute the program, simply copy the whole folder to your host computer and launch the control panel by double clicking the **TR4_ControlPanel.exe**.

CAUTION. Please make sure Quartus II and USB-Blaster Driver are installed before launching TR4 Control Panel. In addition, before the TR4 control panel is launched, it is imperative that the fan is installed on the Stratix IV GX device to prevent excessively high temperatures on the FPGA.

To activate the Control Panel, perform the following steps:

- Make sure Quartus II and Nios II are installed successfully on your PC.
- Connect the supplied USB cable to the USB Blaster port and the supplied power cord to J4. Turn the power switch ON.
- Verify the connection on the USB blaster is available and not occupied or used between Quartus and TR4.

Start the executable **TR4_ControlPanel.exe** on the host computer. **Figure 3-1** will appear and the Control Panel starts to auto-detect the FPGA and download the .sof files.

After the configuration file is programmed to the TR4 board, the FPGA device information will be displayed on the window.

Note. The Control Panel will occupy the USB port; users will not be able to download any configuration file into the FPGA before you exit the Control Panel program.



Figure 3-1 Download .sof Files to the TR4 board

The Control Panel is now ready, as shown in **Figure 3-2**.



Figure 3-2 TR4 Control Panel is Ready

If the connection between TR4 board and USB-Blaster is not established, or the TR4 board is not powered on before running the **TR4_ControlPanel.exe**, the Control Panel will fail to detect the FPGA and a warning message window will pop up as shown in **Figure 3-3**.



Figure 3-3 The TR4 Control Panel Fails to Download .sof File

The concept of the TR4 Control Panel is illustrated in **Figure 3-4**. The “Control Codes” which performs the control functions is implemented in the FPGA board. It communicates with the Control Panel window, which is active on the host computer, via the USB Blaster link. The graphical user interface is used to issue commands to the control codes. It handles all requests and performs data transfer between the computer and the TR4 board.

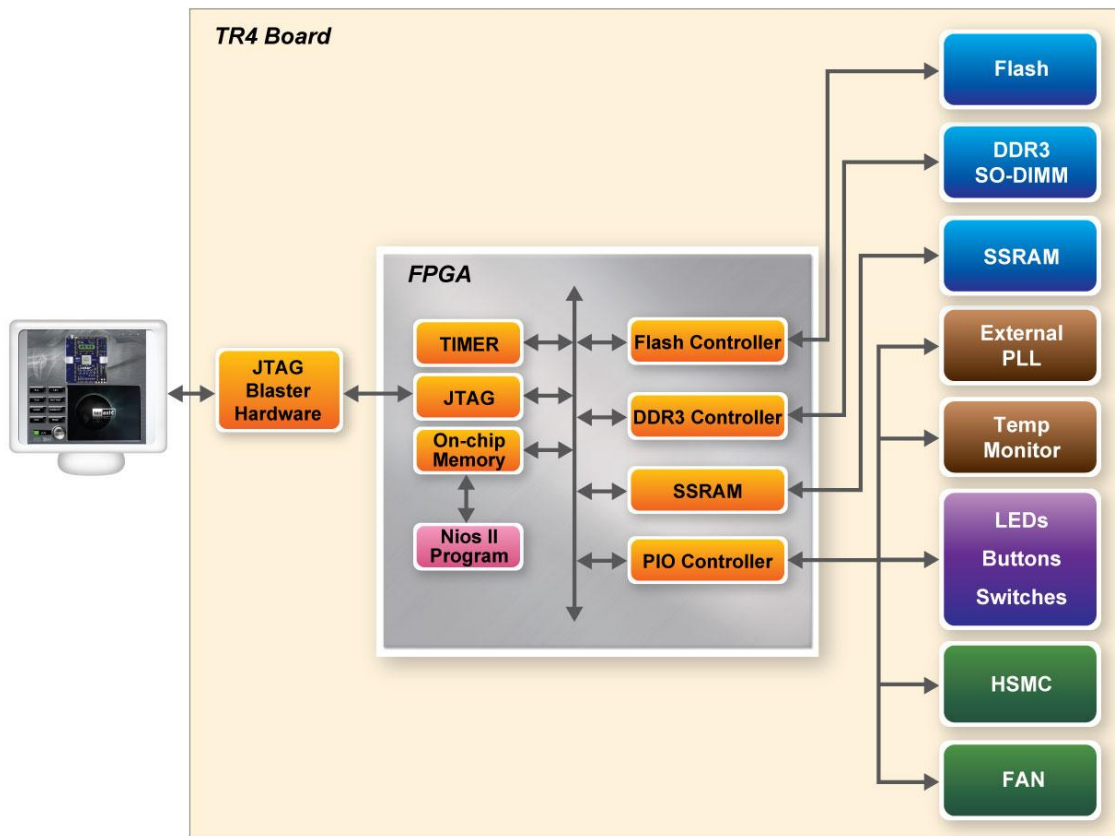

Figure 3-4 TR4 Control Panel Block Diagram

The TR4 Control Panel can be used to illuminate the LEDs, monitoring buttons/switches status, read/write from various memory types, in addition to testing various components of the TR4 board.

3.2 Controlling the LEDs

One of the functions of the Control Panel is to set up the status of the LEDs. The tab-window shown in **Figure 3-5** indicates where you can directly turn all the LEDs on or off individually by selecting them and clicking “Light All” or “Unlight All”.



Figure 3-5 Controlling LEDs

3.3 Switches and Push-Buttons

Choose the **Button** tab as shown in **Figure 3-6**. This function is designed to monitor status of switches and buttons from a graphical user interface in real-time. It can be used to verify the functionality of switches and buttons.



Figure 3-6 Monitoring Switches and Buttons

3.4 Memory Controller

The Control Panel can be used to write/read data to/from the DDR3 SO-DIMM/Flash/SSRAM memory on the TR4 board. We will describe how the DDR3 SO-DIMM is accessed. Click on the Memory tab to reach the tab-window shown in [Figure 3-7](#).

A 16-bit value can be written into the DDR3 SO-DIMM memory by three steps, namely specifying the address of the desired location, entering the hexadecimal data to be written, and pressing the Write button. Contents of the location can be read by pressing the **Read** button. [Figure 3-8](#) depicts the result of writing the hexadecimal value 7EFF to location 0x100, followed by reading the same location.

The Sequential Write function of the Control Panel is used to write the contents of a file to the serial configuration device, as described below:

- Specify the starting address in the **Address** box.
- Specify the number of bytes to be written in the **Length** box. If the entire file is to be loaded, a check mark can be placed in the **File Length** box instead of giving the number of bytes.
- To initiate the writing of data, click on the **Write a File to Memory** button.
- When the Control Panel responds with the standard Windows dialog box asking for the source file, specify the desired file in the usual manner.

The Sequential Read function is used to read the contents of the serial configuration device and place them into a file as follows:

- Specify the starting address in the **Address** box.
- Specify the number of bytes to be copied into a file in the **Length** box. If the entire contents of the serial configuration device are to be copied, then place a check mark in the **Entire Memory** box.
- Press Load Memory Content to a File button.
- When the Control Panel responds with the standard Windows dialog box ask for the destination file, users can specify the desired file in the usual manner.



Figure 3-7 Access DDR3 SO-DIMM Memory



Figure 3-8 Writing the Hexadecimal Value 7EFF to Location 0x100

3.5 Temperature Monitor

Choose the **Temperature** tab to reach the window shown in **Figure 3-9**. This function is designed to control temperature sensor through the Control Panel. The temperatures of Stratix IV GX and TR4 board are shown on the right-hand side of the Control Panel.

When the temperature of Stratix IV GX exceeds the maximum setting of ‘Over Temperature’ or ‘Alert’, a warning message will be shown on the Control Panel. Click “Read” button to get current settings for ‘Over temperature’ and ‘Alert’. Users can enter the maximum and minimum temperatures for ‘Over temperature’ or ‘Alert’ as required. Click the Write button to update the values entered.



Figure 3-9 Accessing the Temperature Sensor through Control Panel

3.6 PLL

The PLL function is designed to configure the external programmable PLL on the TR4. There are 3 programmable clocks for the TR4 board that generates reference clocks for the following signals HSMA_REFCLK_p/n, HSMB_REFCLK_p/n, and PGM_GXBCLK_p1/n1. The clock frequency can be adjusted to 62.5, 75, 100, 125, 150, 156.25, 187.5, 200, 250, 312.5, and 625MHz. Choose the 'PLL' tab to reach the window shown in **Figure 3-10**. To set the desire clock frequency for the associated clock signal, click on 'Set'.



Figure 3-10 Programmable External PLL Configured through Control Panel

3.7 HSMC

Choose the **HSMC** tab to reach the window shown in **Figure 3-11**. This function is designed to verify the functionality of signals found on the HSMC connectors of ports A, B, C, D, E and F using a loopback approach. Before running the loopback verification HSMC test, select the desired HSMC connector to be tested. Follow the instruction noted under *Loopback Installation* section and click on ‘Verify’. Note the Control Panel HSMC loopback test does not test the transceiver signals on the HSMC interface. For HSMC transceiver loopback test, please refer to the demonstration section.

CAUTION. Turn off the TR4 board before the HSMC loopback adapter is mounted to prevent any

damage to the TR4 board.



Figure 3-11 HSMC Loopback Verification Test Performed under Control Panel

3.8 Fan

Choose the **Fan** tab to reach the window shown in **Figure 3-12**. This function is designed to verify the functionality of the fan components and signals. Please make sure the fan is installed on the TR4 before running this function.



Figure 3-12 Fan Control of the TR4

3.9 Information

For more information, please click on the Information button in order to reach the window shown in **Figure 3-13.**, Users can click “Terasic Web” button and “TR4_Web” button to reach the respective websites in order to learn more about the TR4 and Terasic Technologies.



Figure 3-13 Information Tab of TR4 Control Panel

TR4 System Builder

This chapter describes how users can create a custom design project on the TR4 board by using the included TR4 software tool – TR4 System Builder.

4.1 Introduction

The TR4 System Builder is a Windows-based software utility, designed to assist users in creating a Quartus II project for the TR4 board within minutes. The generated Quartus II project files include:

- Quartus II Project File (.qpf)
- Quartus II Setting File (.qsf)
- Top-Level Design File (.v)
- External PLL Controller (.v)
- Synopsis Design Constraints file (.sdc)
- Pin Assignment Document (.htm)

The TR4 System Builder not only can generate the files above, but can also provide error-checking rules to handle situations that are prone to errors. The common mistakes that users encounter are the following:

- Board damaged due to wrong pin/bank voltage assignments
- Board malfunction caused by wrong device connections or missing pin counts for connections
- Poor performance drop due to improper pin assignments

4.2 General Design Flow

This section will introduce the general design flow to build a project for the TR4 board via the TR4 System Builder. The general design flow is illustrated in the **Figure 4-1**.

Users should launch TR4 System Builder and create a new project according to their design requirements. When users complete the settings, the TR4 System Builder will generate two major files which include a top-level design file (.v) and the Quartus II settings file (.qsf).

The top-level design file contains a top-level Verilog wrapper for users to add their own design/logic. The Quartus II settings file contains information such as FPGA device type, top-level pin assignments, and I/O standards for each user-defined I/O pin.

Finally, Quartus II programmer must be used to download SOF file to TR4 board using JTAG interface.

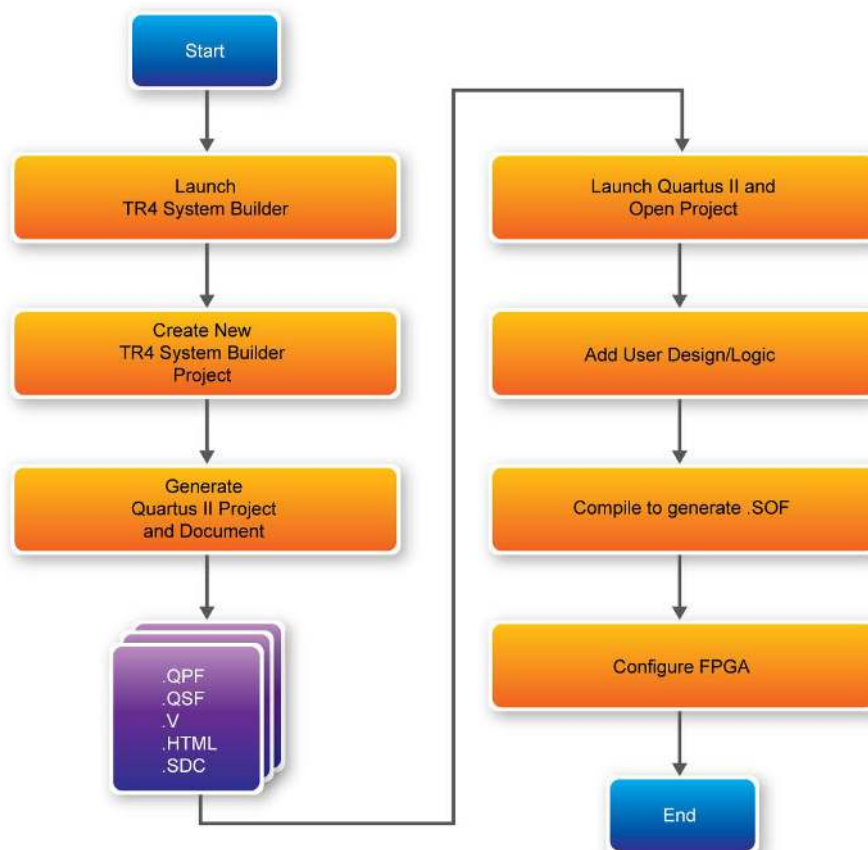

Figure 4-1 General Design Flow

4.3 Using TR4 System Builder

This section provides the detail procedures on how the TR4 System Builder is used.

Install and launch the TR4 System Builder

The TR4 System Builder is located in the directory: "**Tools\TR4_SystemBuilder**" in the TR4 System CD. Users can copy the whole folder to a host computer without installing the utility. Before using the TR4 System Builder, execute the **TR4_SystemBuilder.exe** on the host computer as appears in **Figure 4-2**.

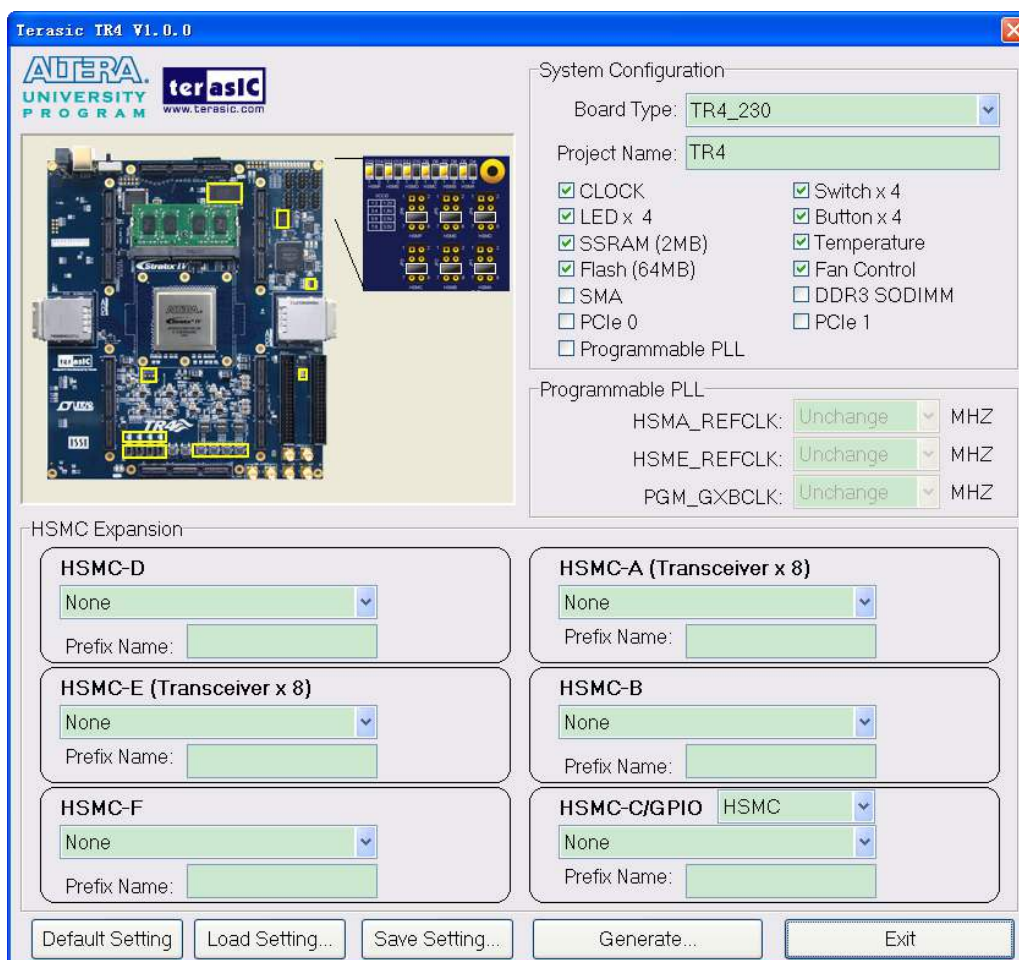

Figure 4-2 TR4 System Builder Window

Select Board Type and Input Project Name

Select the target board type and input project name as show in **Figure 4-3**.

- Board Type: Select the appropriate FPGA device according to the TR4 board which includes the EP4SGX230 and EP4SGX530 devices.
- Project Name: Specify the project name as it is automatically assigned to the name of the top-level design entity.

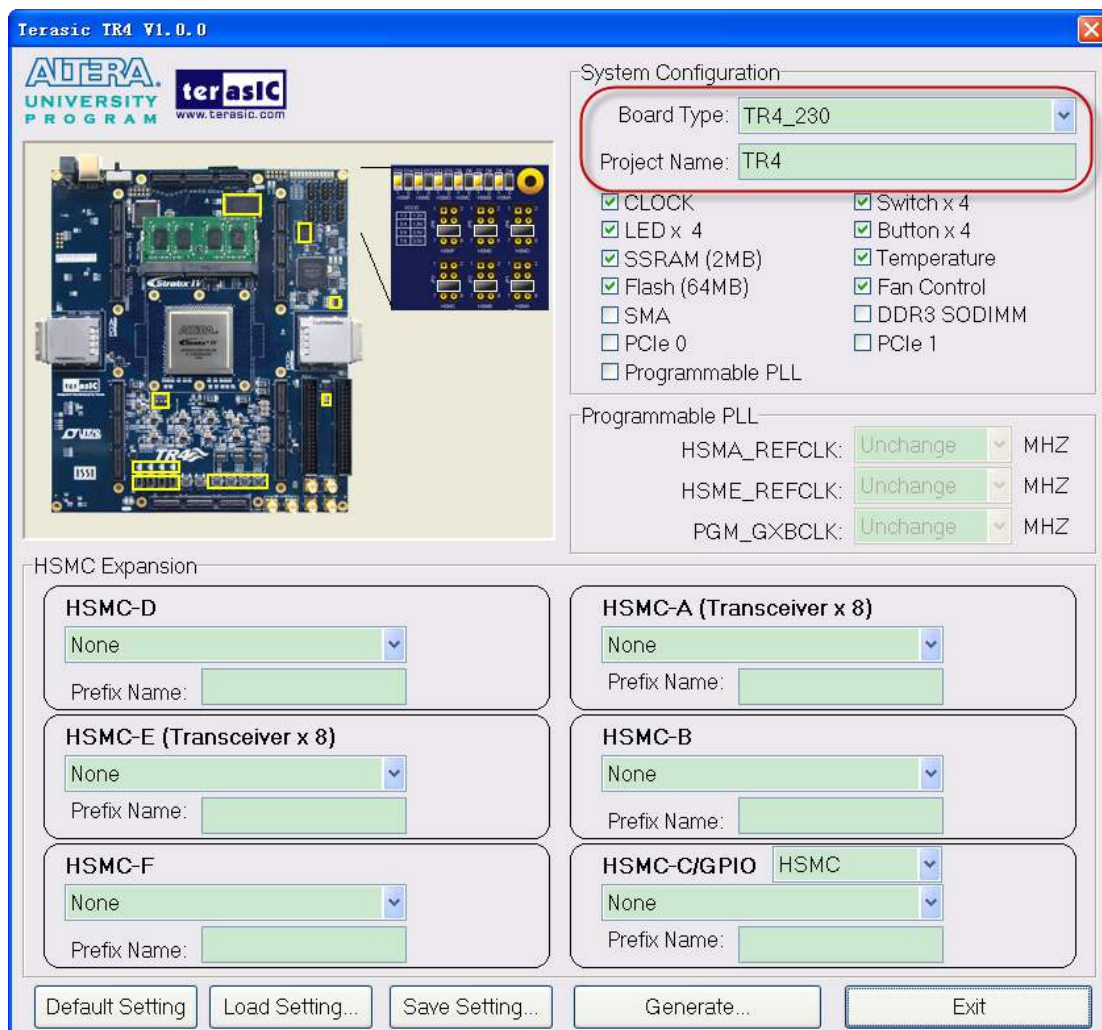

Figure 4-3 TR4 Board Type and Project Name

System Configuration

Under System Configuration, users are given the flexibility of enabling their choice of components

on the TR4 as shown in **Figure 4-4**. Each component of the TR4 is listed where users can enable or disable a component according to their design by simply marking a check or removing the check in the field provided. If the component is enabled, the TR4 System Builder will automatically generate the associated pin assignments including the pin name, pin location, pin direction, and I/O standards.

Note. The pin assignments for some components for e.g. DDR3 require associated controller codes in the Quartus II project otherwise Quartus II will result in compilation errors. Therefore, do not select them if they are not necessary in your design.

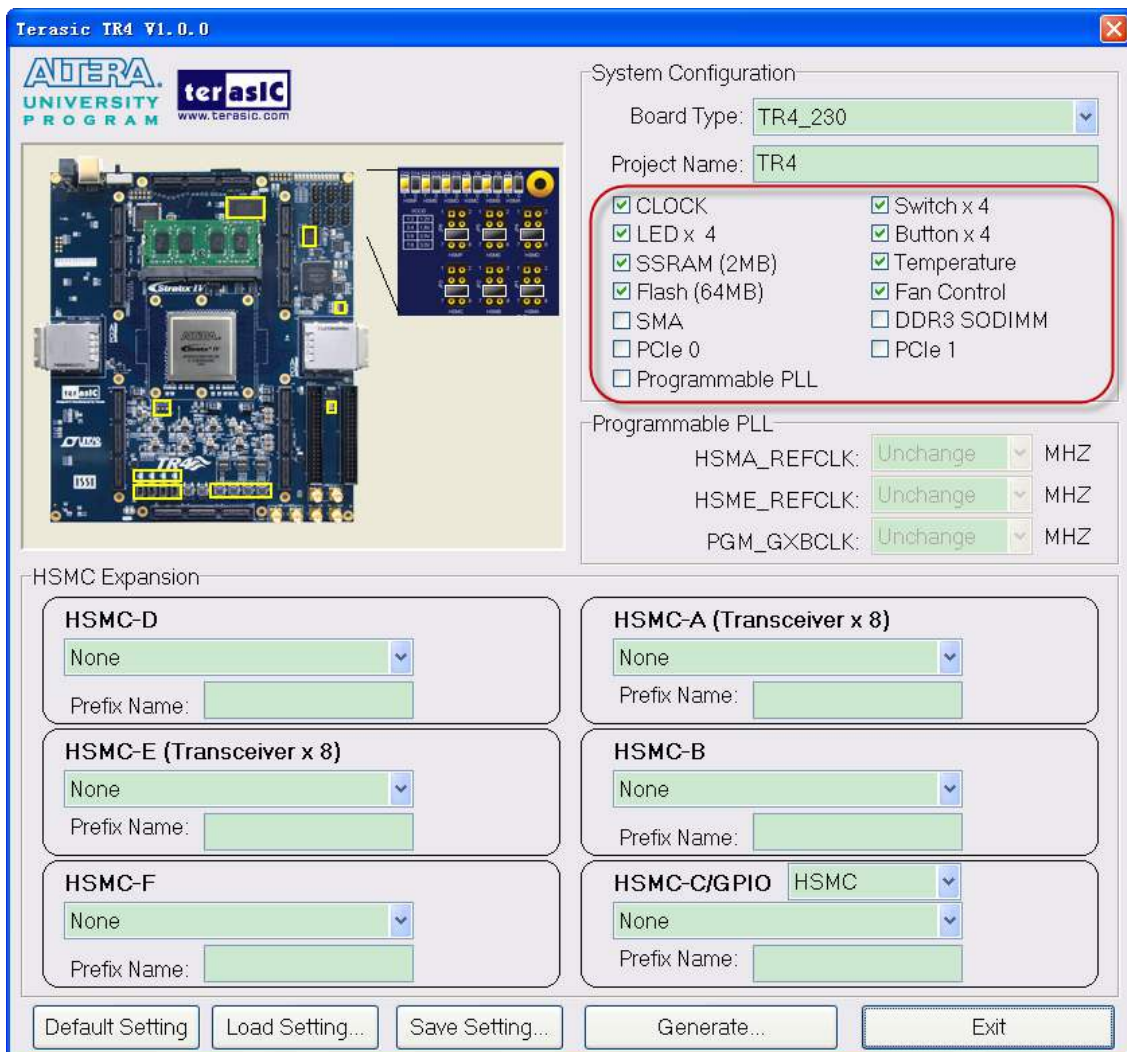

Figure 4-4 System Configuration Group

Programmable PLL

There are three external programmable PLLs on-board that provide reference clocks for the following signals HSMA_REFCLK, HSME_REFCLK and PGM_GXBCLK. To use these PLLs, users can select the desired frequency on the Programmable PLL group, as shown in Figure 4-5.

As the Quartus II project is created, System Builder automatically generates the associated PLL configuration code according to users' desired frequency in Verilog which facilitates users' implementation as no additional control code is required to configure the PLLs.

Note. If users need to dynamically change the frequency, they will need to modify the generated control code themselves.

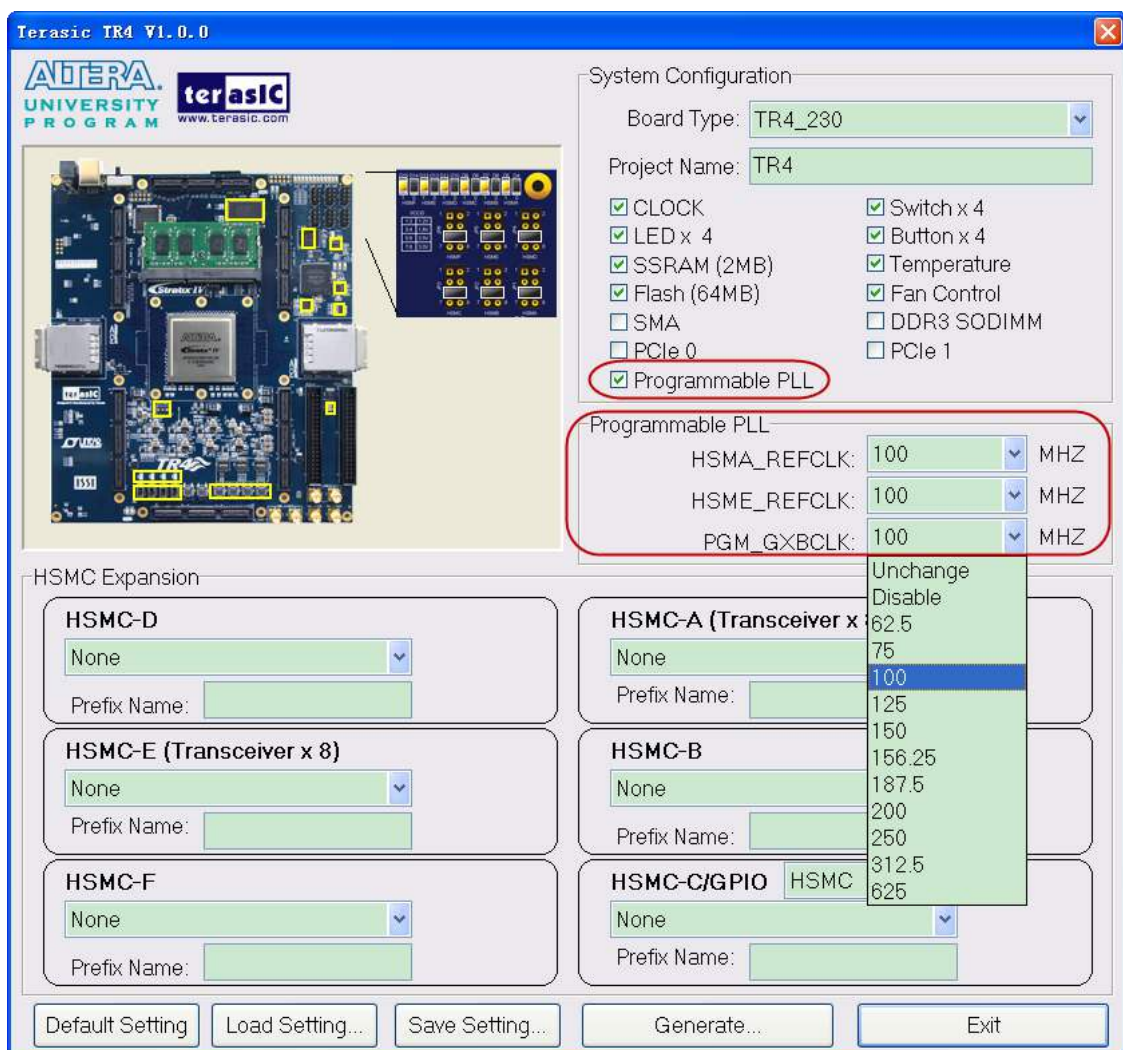

Figure 4-5 External Programmable PLL

HSMC Expansion

Users can connect HSMC-interfaced daughter cards onto the HSMC ports located on the TR4 board shown in **Figure 4-6**. Select the daughter card you wish to add to your design under the appropriate HSMC connector where the daughter card is connected to. The System Builder will automatically generate the associated pin assignment including pin name, pin location, pin direction, and IO standard.

If a customized daughter board is used, users can select “HSMC Default” followed by changing the pin name, pin direction, and IO standard according to the specification of the customized daughter board. If transceiver pins are not required on the daughter board, please remember to remove it, otherwise Quartus II will report errors.

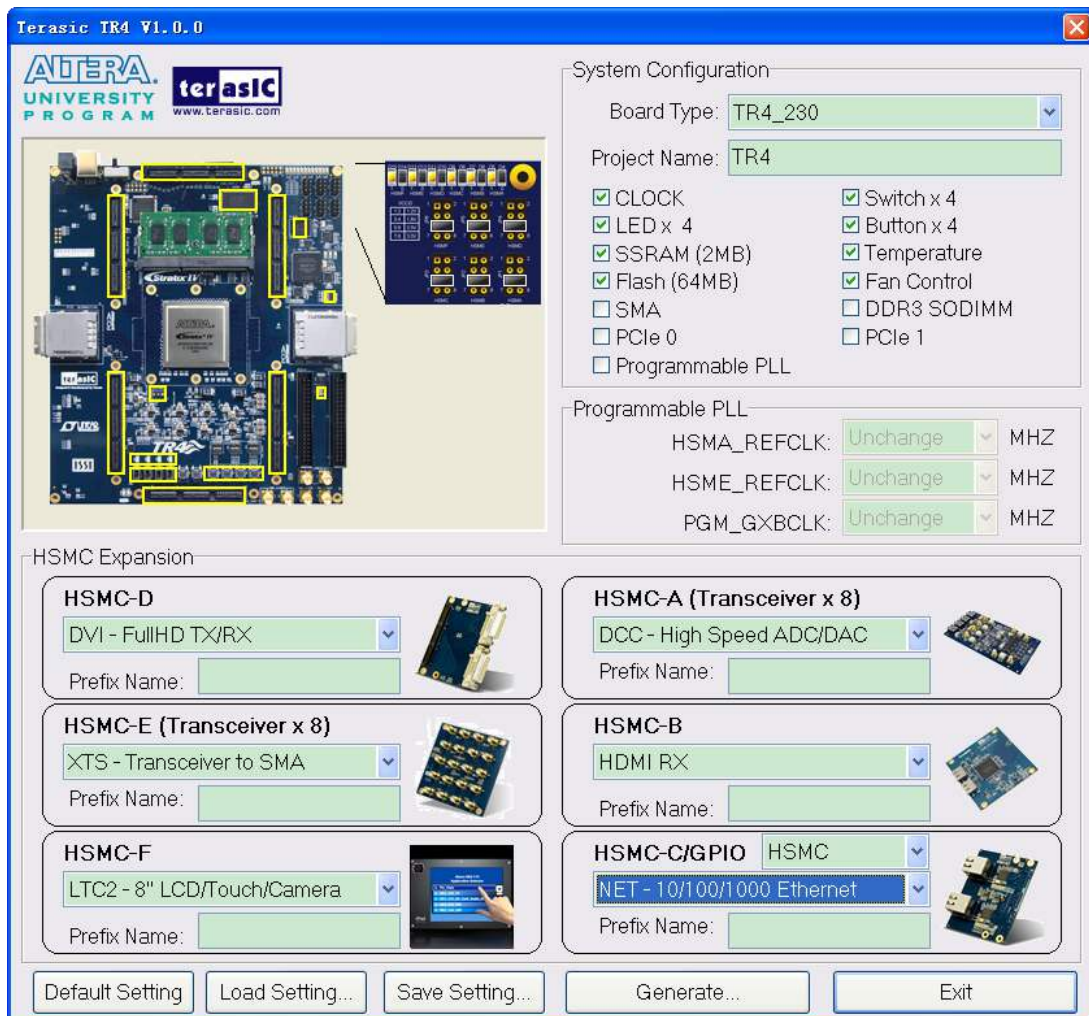

Figure 4-6 HSMC Expansion Group

The “Prefix Name” is an optional feature that denotes the pin name of the daughter card assigned in your design. Users may leave this field empty.

Note. If the same HSMC daughter card is selected in both HSMC-A and HSMC-B expansion, a prefix name is required to avoid pin name duplication as shown in **Figure 4-7**, otherwise System Builder will prompt an error message.

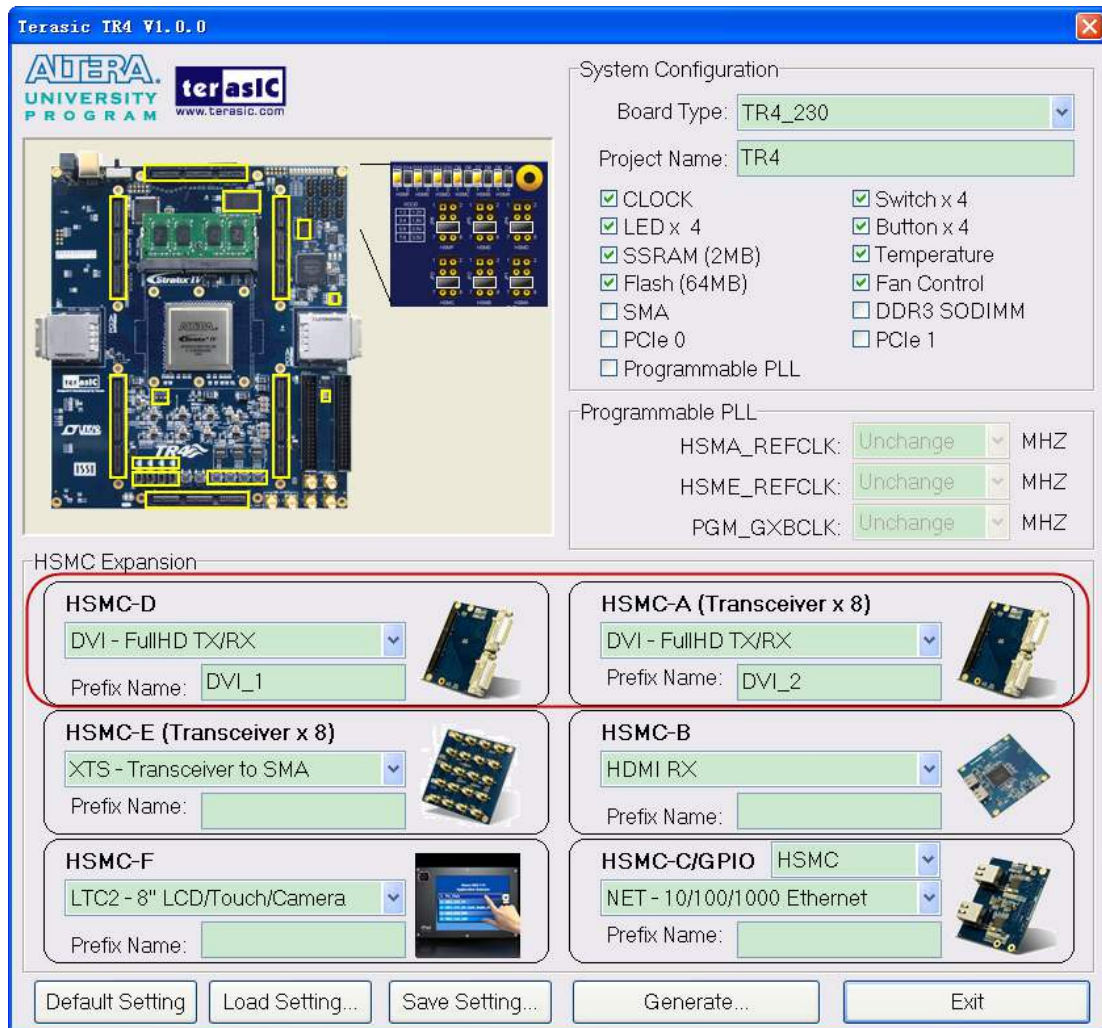

Figure 4-7 Specify Prefix Name for HSMC Expansion Board

Additionally, users can choose the “HSMC-C/GPIO” as either “HSMC” or “GPIO”, since the GPIO ports share pins with HSMC Port C as shown in **Figure 4-8**.

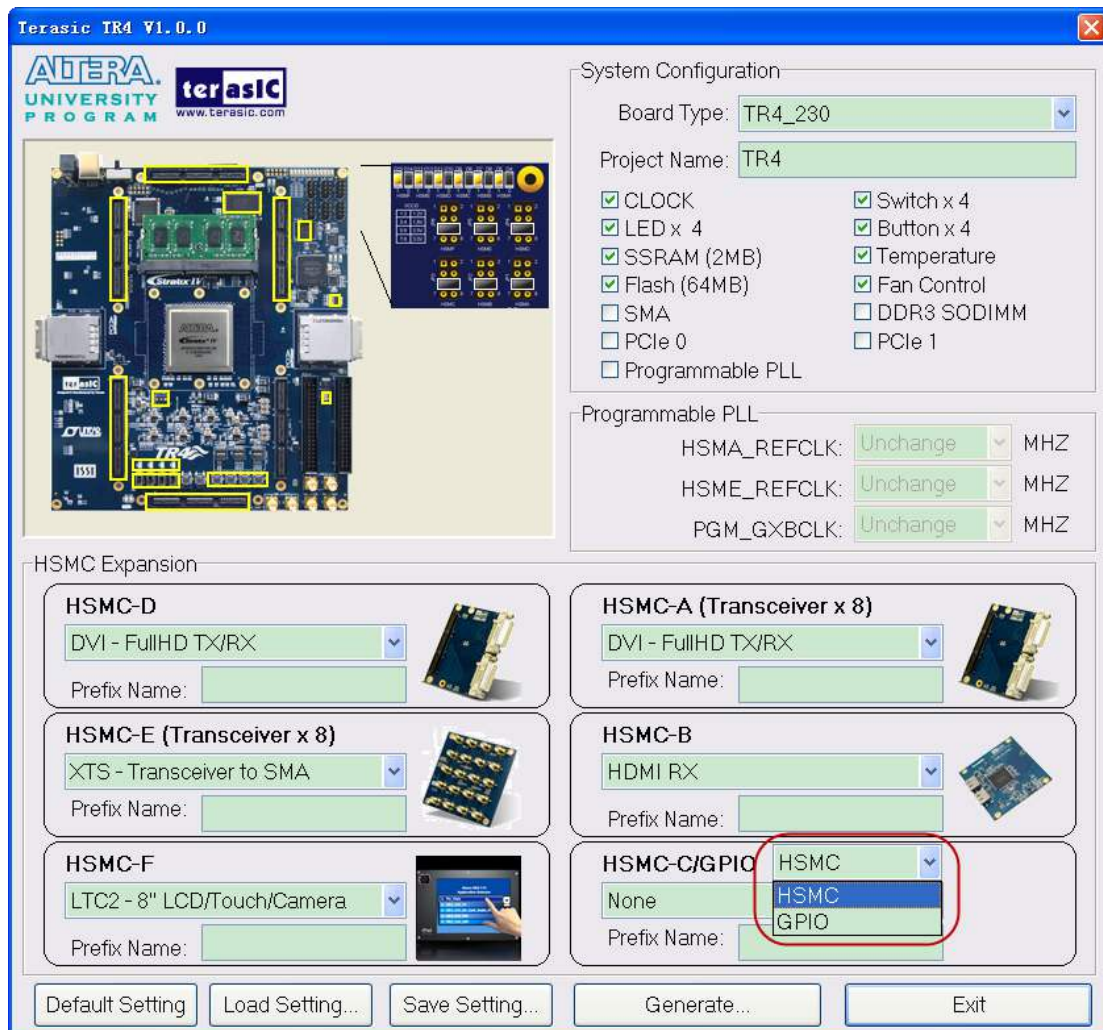

Figure 4-8 HSMC-C/GPIO share pins option

After users select the “GPIO” option, a “GPIO Edit” button will appear. If this is clicked, a “GPIO Expansion” window will pop up for users to select a compatible Terasic daughter card. Once a daughter card selected, the JP4 header diagram in the upper left hand corner of the window, which configures HSMC Port C and GPIO I/O standards will adjust automatically to recommend a suitable I/O standard for the selected daughter card as shown in **Figure 4-9**.

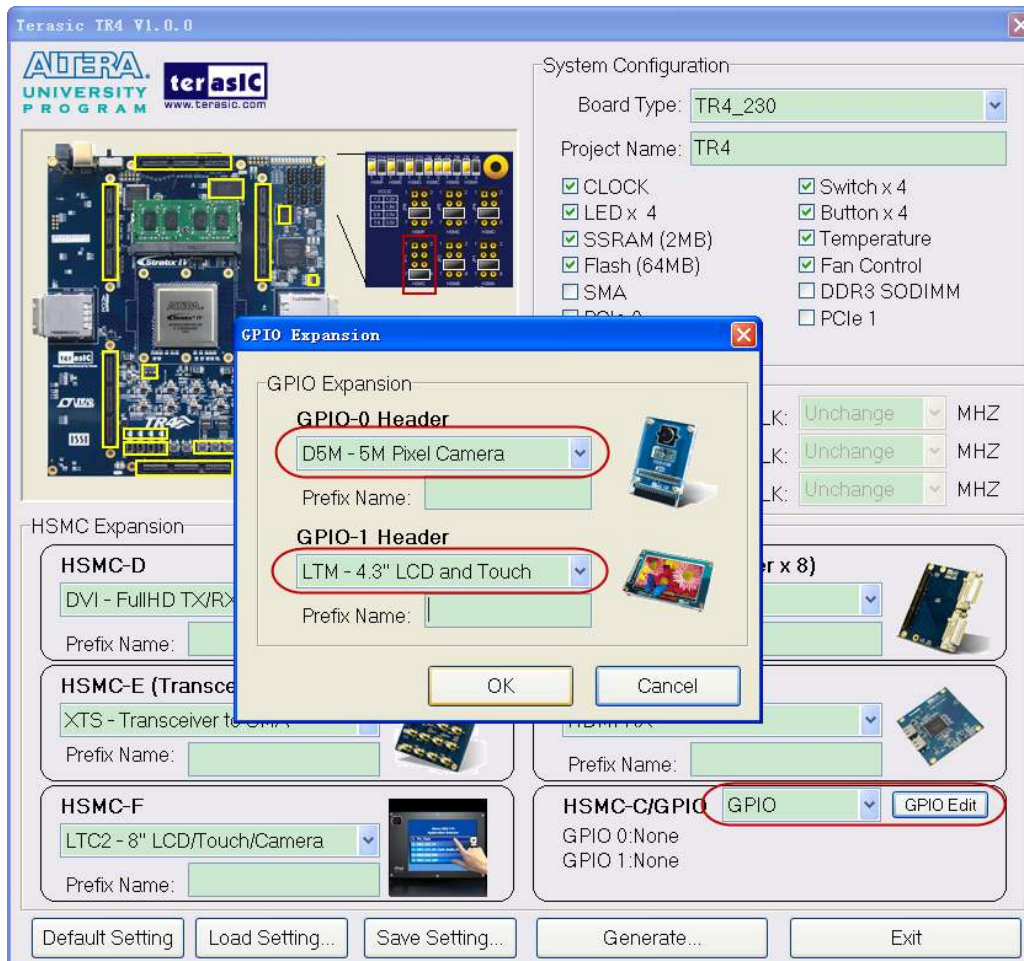

Figure 4-9 GPIO option and I/O standard recommend

Project Setting Management

The TR4 System Builder also provides functions to restore a default setting, loading a setting, and saving users' board configuration file shown in **Figure 4-10**. Users can save the current board configuration information into a .cfg file and load it to the TR4 System Builder.

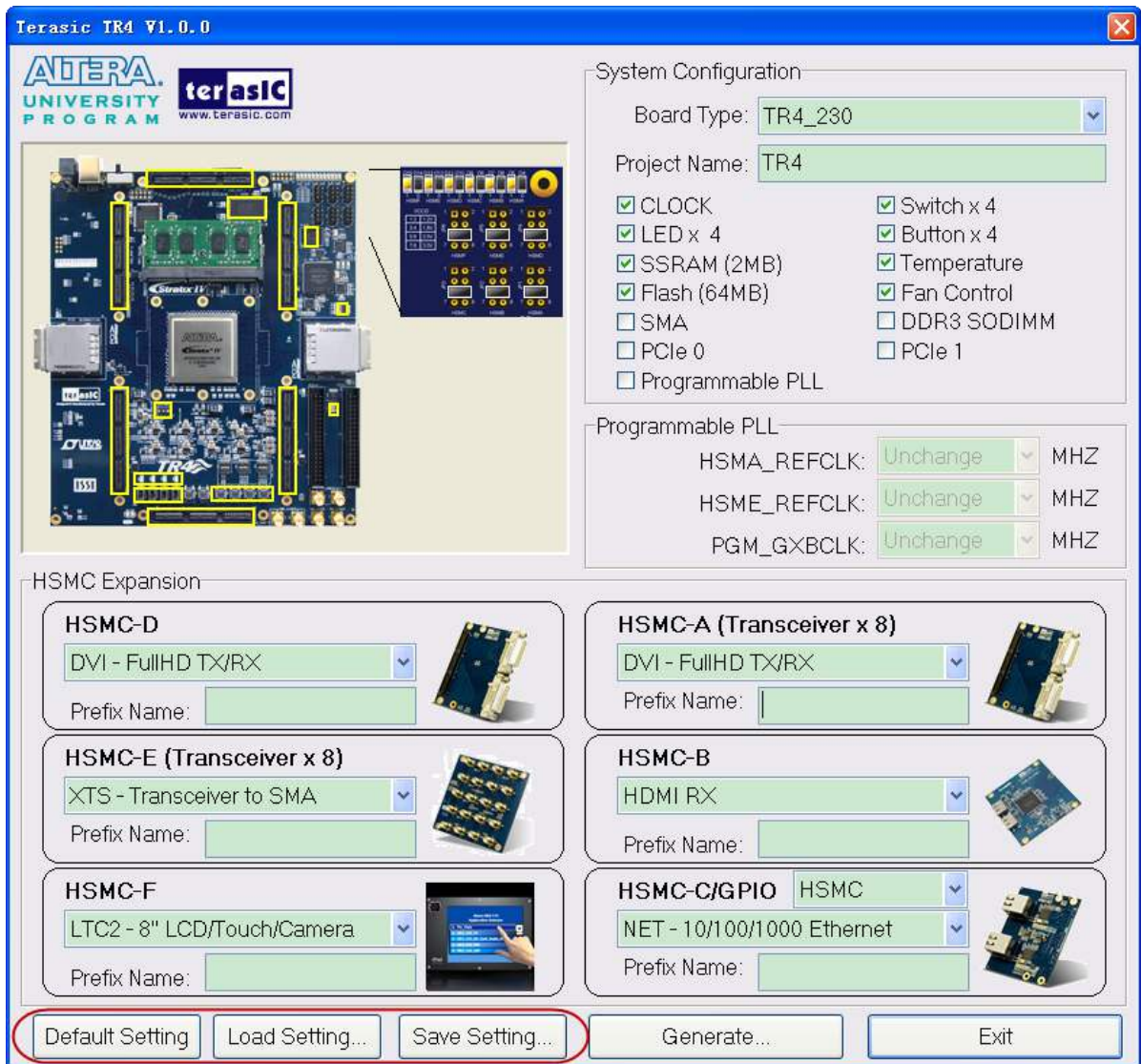

Figure 4-10 Project Settings

Project Generation

When users press the **Generate** button, the TR4 System Builder will generate the corresponding Quartus II files and documents as listed in the **Table 4-1** in the directory specified by the user.

Table 4-1 Files Generated by TR4 System Builder

No.	Filename	Description
1	<Project name>.v	Top level Verilog file for Quartus II
2	EXT_PLL_CTRL.v	External PLL configuration controller IP
3	<Project name>.qpf	Quartus II Project File

4	<Project name>.qsf	Quartus II Setting File
5	<Project name>.sdc	Synopsis Design Constraints file for Quartus II
6	<Project name>.htm	Pin Assignment Document

Users can use Quartus II software to add custom logic into the project and compile the project to generate the SRAM Object File (.sof).

In addition, External Programmable PLL Configuration Controller IP will be instantiated in the Quartus II top-level file as listed below:

```

ext_pll_ctrl  u_ext_pll_ctrl
(
    // system input
    .osc_50(OSC_50_BANK1),
    .rstn(rstn),
    // device 1
    .clk1_set_wr(clk1_set_wr),
    .clk1_set_rd(),
    // device 2
    .clk2_set_wr(clk2_set_wr),
    .clk2_set_rd(),
    // device 3
    .clk3_set_wr(clk3_set_wr),
    .clk3_set_rd(),
    // setting trigger
    .conf_wr(conf_wr),           // 1T 50MHz
    .conf_rd(),                 // 1T 50MHz
    // status
    .conf_ready(),
    // 2-wire interface
    .max_sclk(MAX2_I2C_SCL),
    .max_sdat(MAX2_I2C_SDA)
);

```

If dynamic PLL configuration is required, users need to modify the code according to users' desired PLL behavior.

Chapter 5

Examples of Advanced Demonstration

This chapter introduces several advanced designs that demonstrate Stratix IV GX features using the TR4 board. The provided designs include the major features on board such as the HSMC connectors, PCIe, and DDR3. For each demonstration the Stratix IV GX FPGA configuration file is provided, as well as full source code in Verilog HDL. All of the associated files can be found in the *demonstrations\tr4_<Stratix device>* folder from the **TR4 System CD**. For each of demonstrations described in the following sections, we give the name of the project directory for its files, which are sub-directories of the *demonstrations\tr4_<Stratix_device>* folder.

5.1 Fix Qsys Issue for Quartus 20.1.1

Since the Qsys tool of the Quartus version 20.1.1 lacks some library files, this will cause users to encounter errors when regenerating their Qsys project (see **Figure 5-1**). Users may encounter it when modifying the examples such as **PCIE_DDR3**, **PCie_Fundamental** and **TR4_DDR3_UniPHY_1G_QSYS**. Please refer to the following link to fix this issue:
http://www.terasic.com.tw/wiki/Fix_Known_Issues_Quartus_QSYS_regenerating_error .

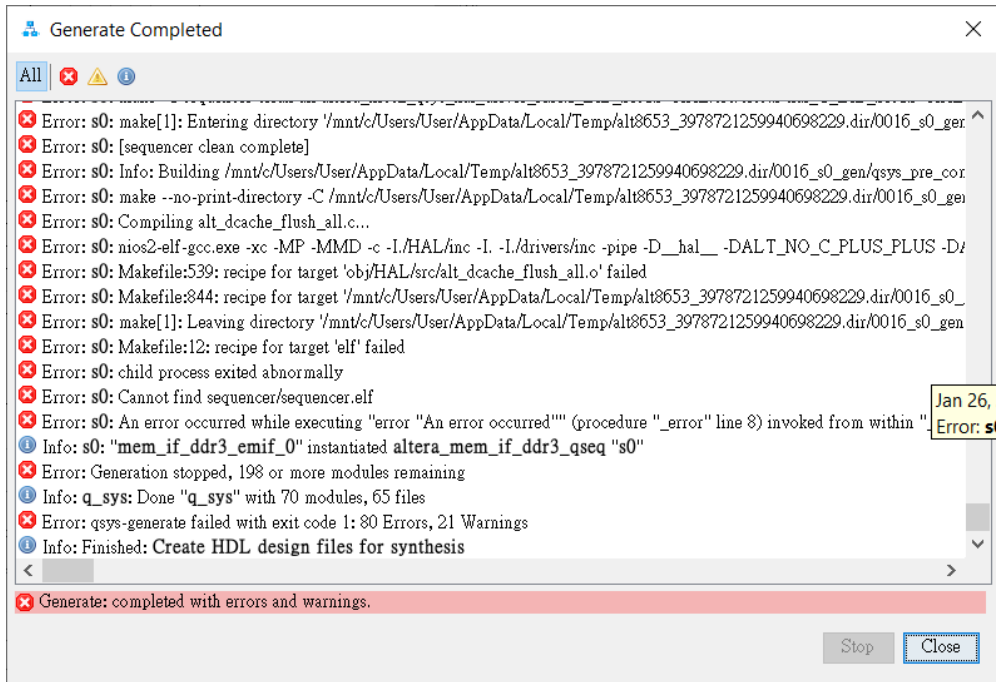

Figure 5-1 Qsys regenerating error

5.2 Breathing LEDs

This demonstration shows how to use the FPGA to control the luminance of the LEDs by means of dividing frequency. By dividing the frequency from 50 MHz to 1 Hz, you can see LED flash once per second.

Design Tools

- Quartus Prime 20.1.1 Standard Edition

Demonstration Source Code

- Project directory: *Breathing_LEDs*
- Bit stream used: *Breathing_LEDs.sof*

Demonstration Batch File

- Demo Batch File Folder: Breathing_LEDs\ Demo_batch
- The demo batch file includes following files:
- Batch File: Breathing_LEDs.bat
- FPGA Configuration File: Breathing_LEDs.sof

Demonstration Setup

- Make sure Quartus Prime 20.1.1 Standard Edition and Nios II EDS 20.1.1 are installed on your PC.
- Connect the USB Blaster cable to the TR4 board and host PC. Install the USB Blaster driver if necessary.
- Power on the TR4 board.
- Execute the demo batch file “Breathing_LEDs.bat” under the batch file folder, TR4_Breathing_LEDs\Demo_batch.
- Press **BUTTON0** of the TR4 board to reset.
- The LEDs will pulse according to the set frequency.

5.3 External Clock Generator

The External Clock Generator provides designers with 3 programmable clock generators via Texas Instruments chips (CDCM61001RHBT x 2, CDCM61004RHBT) with the ability to specify the clock frequency individually, as well as addressing the input reference clock for the Stratix IV GX transceivers. The programmable clock is controlled by a control bus connected to the MAX II EPM2210 device. This can reduce the Stratix IV GX I/O usage while enabling greater functionality on the FPGA device. The MAX II EPM2210 device is capable of storing the last entered clock settings at which in the event the board restarts, the last known clock settings are fully restored. In this demonstration, we illustrate how to utilize the clock generators IP to define the clock output using the serial bus. The programmable clock outputs generate clock signals HSMA_REFCLK_p/n (CDCM61001/01), PGM_GXBCLK_p1/n1 (CDCM61004), and HSME_REFCLK_p/n (CDCM61001/02) with adjustable output clock frequencies of 62.5, 75, 100, 125, 150, 156.25, 187.5, 200, 250, 312.5, and 625MHz. The I/O standard for the clock frequencies is set to LVDS which is not configurable.

An overall block diagram of the external clock generator is shown below in **Figure 5-1**.

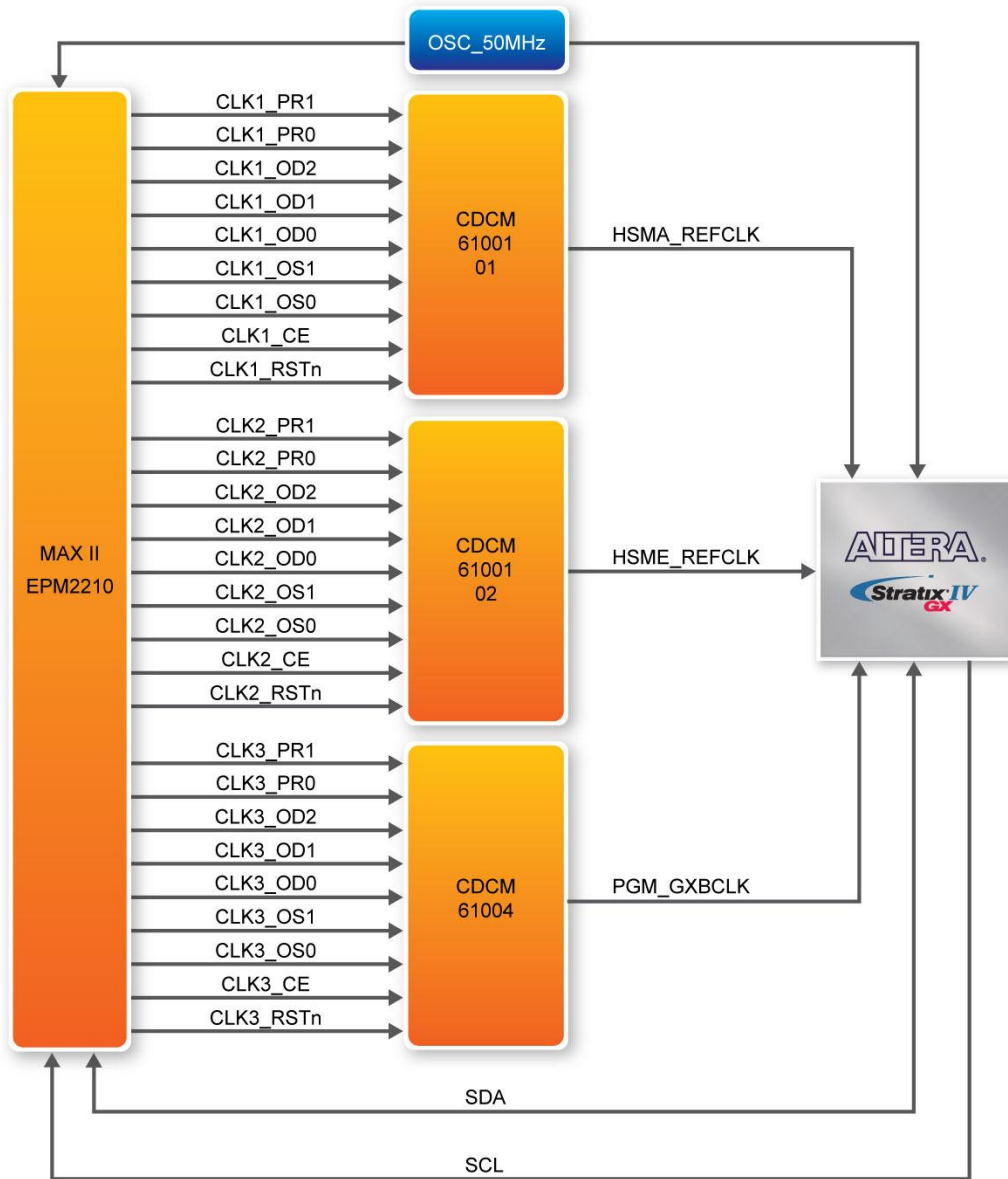

Figure 5-2 External Clock Generator Block Diagram

The EXT_PLL_CTRL IP Port Description

This section describes the operation for the EXT_PLL_CTRL instruction hardware port. **Figure 5-3** shows the EXT_PLL_CTRL instruction block diagram connected to the MAX II EPM2210 device.

The EXT_PLL_CTRL controller module is defined by a host device, the Stratix IV GX FPGA and a slave device, the MAX II EPM2210. Through the I2C bus interface, the EXT_PLL_CTRL controller is able to control the Max II device by specifying the desired clock outputs set by the user. By changing the IP parameters of the Terasic EXT_PLL_CTRL IP, the external clock output frequency can be adjusted accordingly.

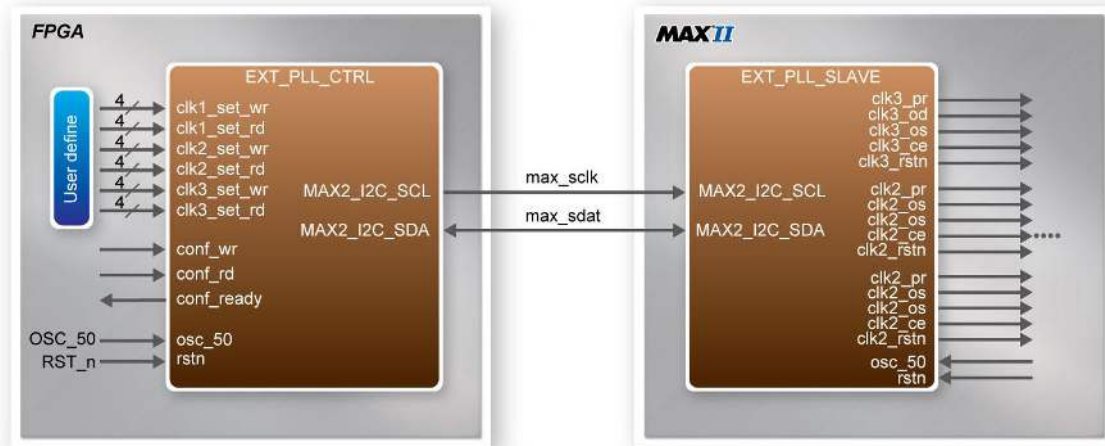

Figure 5-3 EXT_PLL_CTRL Instruction Hardware Ports

Table 5-1 lists the EXT_PLL_CTRL instruction ports

Table 5-1 EXT_PLL_CTRL Instruction Ports

Port Name	Direction	Description
osc_50	input	System Clock (50MHz)
rstn	input	Synchronous Reset (0: Module Reset, 1: Normal)
clk1_set_wr clk2_set_wr clk3_set_wr	input	Setting Output Frequency Value
clk1_set_rd clk2_set_rd clk3_set_rd	output	Read Back Output Frequency Value
conf_wr	Input	Start to Transfer Serial Data (positive edge)
conf_rd	Input	Start to Read Serial Data (positive edge)
conf_ready	Output	Serial Data Transmission is Complete (0: Transmission in Progress, 1: Transmission Complete)
max_sclk	Output	Serial Clock to MAX II
max_sdat	Inout	Serial Data to/from MAX II

The EXT_PLL_CTRL IP Parameter Setting

Users can refer to the following **Table 5-2** to set the external clock generator for the output frequency.

Table 5-2 EXT_PLL_CTRL Instruction Ports

<i>clk1_set_wr/ clk2_set_wr/ clk3_set_wr</i>	<i>Output Frequency (MHz)</i>	<i>Description</i>	
4'b0001	x	Clock Generator Disable	
4'b0010	62.5	Setting External Clock Generator	
4'b0011	75		
4'b0100	100		
4'b0101	125		
4'b0110	150		
4'b0111	156.23		
4'b1000	187		
4'b1001	200		
4'b1010	250		
4'b1011	312.5		
4'b1100	625		
Others	x		Setting Unchanged

The EXT_PLL_CTRL IP Timing Diagram

In this reference design the output frequency is set to 62.5, 75 and 100 MHz with the following timing diagrams illustrated below.

When the ext_pll_ctrl IP receives the 'conf_wr' signal, the user needs to define (clk1_set_wr, clk2_set_wr and clk3_set_wr) to set the External Clock Generator. When the ext_pll_ctrl IP receives the 'conf_rd' signal, it will read the value back to clk1_set_rd, clk2_set_rd, and clk3_set_rd.

Write Timing Waveform:

As **BUTTON1** (the trigger source defined by Terasic) is pressed, the 'conf_wr' signal is on the rising edge, serial data is transferred immediately with the 'conf_ready' signal in the transmission period starting at falling edge level as shown in **Figure 5-4**. As the transfer is completed, the

'conf_ready' signal returns back to original state at high-level.

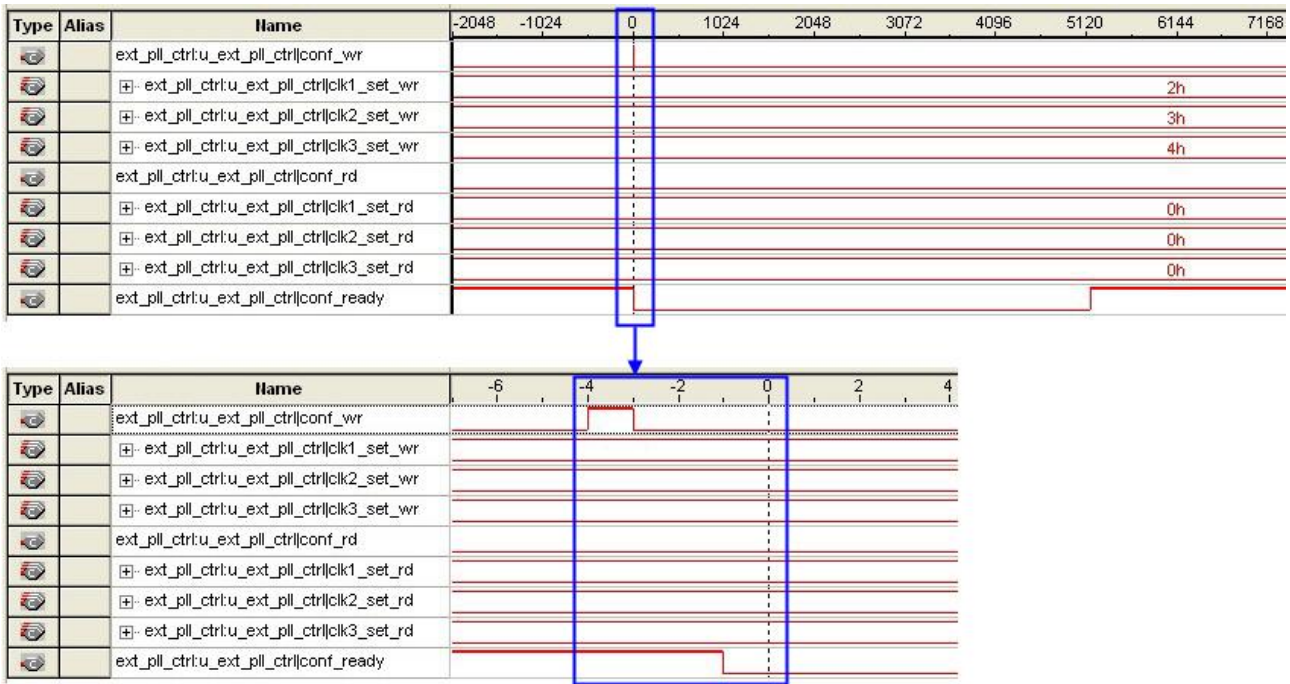

Figure 5-4 Write Timing Waveform

Read Timing Waveform:

As **BUTTON2** (the trigger source defined by Terasic) is pressed the 'conf_rd' signal is on the rising edge, the user settings are read back immediately once the 'conf_ready' signal is on the falling edge as shown in **Figure 5-4**. As the transfer is complete, the 'conf_ready' returns back to original state at high-level.

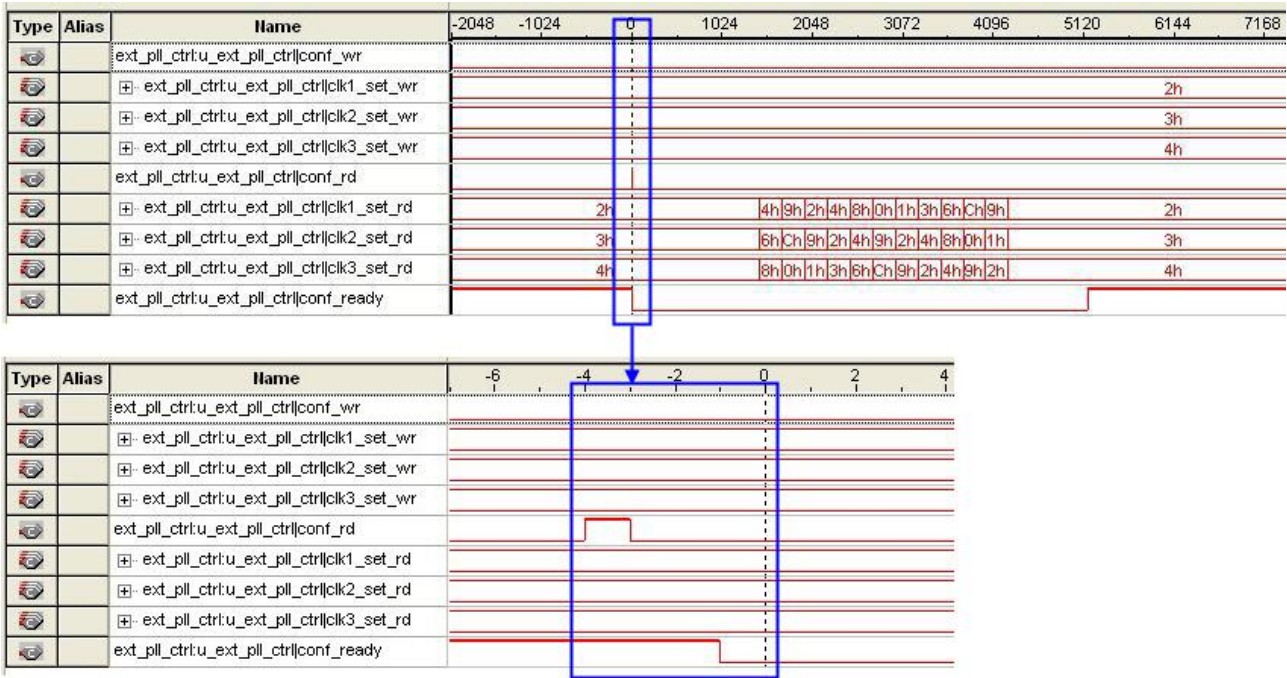

Figure 5-5 Read Timing Waveform

Design Tools

- Quartus Prime 20.1.1 Standard Edition

Demonstration Source Code

- Project directory: *TR4_EXT_PLL*
- Bit stream used: *TR4_EXT_PLL.sof*
- Demonstration Batch File
- Demo Batch File Folder: *TR4_EXT_PLL\demo_batch*

The demo batch file folders include the following files:

- Batch File: *TR4_EXT_PLL.bat*
- FPGA Configuration File: *TR4_EXT_PLL.sof*

Demonstration Setup

- Make sure Quartus Prime 20.1.1 Standard Edition are installed on your PC.
- Connect the USB Blaster cable to the TR4 board and host PC. Install the USB Blaster driver if necessary.
- Power on the TR4 board.
- Execute the demo batch file “*TR4_EXT_PLL.bat*” under the batch file folder, *TR4_EXT_PLL\demo_batch*
- Press **BUTTON0** to configure the external PLL chips via MAX CPLD.

5.4 High Speed Mezzanine Card (HSMC)

The HSMC loopback demonstration reference design observes the traffic flow with an HSMC loopback adapter which provides a quick way to implement your own design utilizing the transceiver signals situated on the HSMC interface. This design also helps you verify the transceiver signals functionality for ports A and E of the HSMC interface. A total of 8 transceiver pairs on the HSMC Port A and port E each are tested.

HSMC Port A Loopback Test:

Demonstration Source Code

Quartus Project directory: *TR4_HSMA_LOOPBACK_TEST*

FPGA Bit Stream: *TR4_HSMA_LOOPBACK_TEST.sof*

Demonstration Batch File

- Demo Batch File Folder: *TR4_HSMA_LOOPBACK_TEST\demo_batch*
- The demo batch file includes following files:
 - Batch File: *TR4_HSMA_LOOPBACK_TEST.bat*
 - FPGA Configuration File: *TR4_HSMA_LOOPBACK_TEST.sof*

Demonstration Setup

- Make sure Quartus Prime 20.1.1 Standard Edition and Nios II EDS 20.1.1 are installed on your PC.
- Insert the HSMC loopback adapter onto the HSMC Port A.
- Connect the USB Blaster cable to the TR4 board and host PC. Install the USB Blaster driver if necessary.
- Power on the TR4 board.
- Execute the demo batch file “TR4_HSMA_LOOPBACK_TEST.bat” under the batch file folder, TR4_HSMA_LOOPBACK_TEST\demo_batch.
- Press **BUTTON0** of the TR4 board to initiate the verification process.
- LED [3:0] will flash indicating the loopback test passed.

HSMC Port E Loopback Test:

Demonstration Source Code

Quartus Project directory: *TR4_HSME_LOOPBACK_TEST*

FPGA Bit Stream: *TR4_HSME_LOOPBACK_TEST.sof*

Demonstration Batch File

- Demo Batch File Folder: TR4_HSME_LOOPBACK_TEST\demo_batch
- The demo batch file includes following files:
 - Batch File: TR4_HSME_LOOPBACK_TEST.bat
 - FPGA Configuration File: TR4_HSME_LOOPBACK_TEST.sof

Demonstration Setup

- Make sure Quartus Prime 20.1.1 Standard Edition and Nios II EDS 20.1.1 are installed on your PC.
- Insert the HSMC loopback daughter card onto the HSMC Port E as shown in Figure 5-6.
- Connect the USB Blaster cable to the TR4 board and host PC. Install the USB Blaster driver if necessary.
- Power on the TR4 board.
- Execute the demo batch file “TR4_HSME_LOOPBACK_TEST.bat” under the batch file folder, TR4_HSME_LOOPBACK_TEST\demo_batch.
- Press **BUTTON0** on the TR4 board to initiate the verification process

- LED [3:0] will flash once to indicate the loopback test passed.

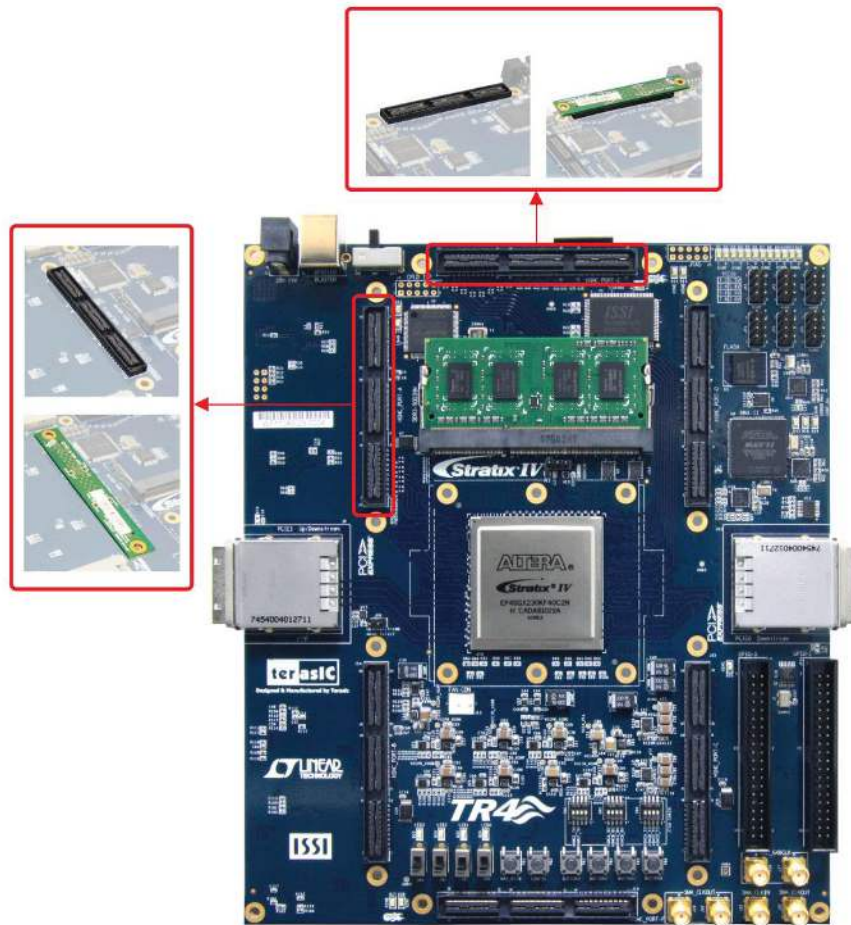

Figure 5-6 HSMC Loopback Design Setup

5.5 DDR3 SDRAM (1GB)

Many applications use a high performance RAM, such as a DDR3 SDRAM to provide temporary storage. In this demonstration hardware and software designs are provided to illustrate how the DDR3 SDRAM SODIMM on the TR4 can be accessed. We describe how the Altera’s “DDR3 SDRAM Controller with UniPHY” IP is used to create a DDR3-SDRAM controller, and how the Nios II processor is used to read and write the SDRAM for hardware verification. The DDR3 SDRAM controller handles the complex aspects of using DDR3-SDRAM by initializing the memory devices, managing SDRAM banks, and keeping the devices refreshed at appropriate intervals. The required DDR3-SDRAM SODIMM module should be 1 GB DDR3-1066.

System Block Diagram

Figure 5-6 shows the system block diagram of this demonstration. The system requires a 50 MHz clock provided from the board. The DDR3 controller is configured as a 1GB DDR3-1066 controller. The DDR3 IP generates one 533.0 MHz clock as memory clock and one quarter-rate system clock 133.125 MHz for controllers, e.g. Nios II processor, accessing the SDRAM. In Qsys, Nios II and On-Chip Memory are designed running with the 133.125 MHz clock, and the other controllers are designed running with 50 MHz clock which is the external clock. The Nios II program itself is running in the on-chip memory.

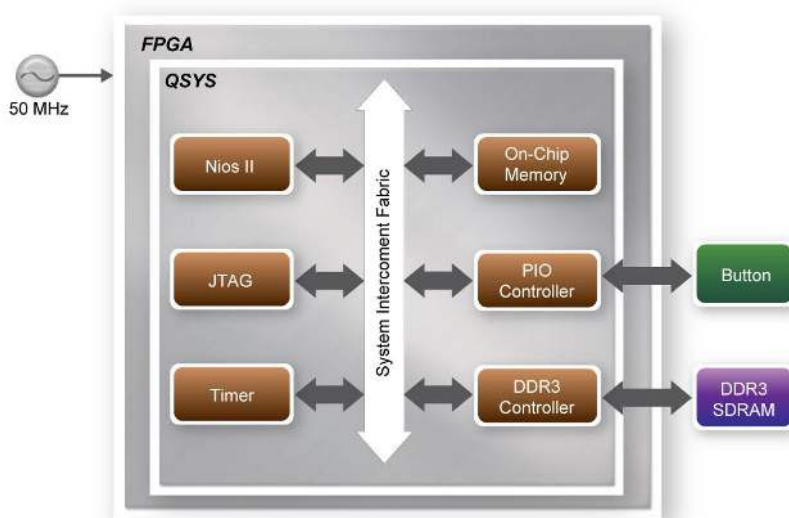

Figure 5-7 Block diagram of the DDR3 1G demonstration

The system flow is controlled by a Nios II program. First, the Nios II program writes test patterns into the DDR3, filling it up to maximum capacity. Then, it calls a Nios II system function, `alt_dache_flush_all`, to make sure all data has been written. Finally, it reads data from DDR3 for data verification. The program will show progress in JTAG-Terminal when writing/reading data to/from the DDR3. When the verification process is completed, the result is displayed in the JTAG-Terminal.

Altera DDR3 SDRAM Controller with UniPHY

To use the Altera DDR3 controller, users need to perform three major steps: 1). Create correct pin assignments for the DDR3. 2). Set up correct parameters in DDR3 controller dialog. 3). Execute

TCL files, generated by DDR3 IP, under your Quartus II project.

The following section describes some of the important issues in support of the DDR3 controller configuration. On the “PHY_Setting” tab, in order to achieve 533.0 MHz clock frequency, a reference clock frequency of 50 MHz should be used. If a different DDR3 SODIMM is used, the memory parameters should be modified according to the datasheet of the DDR3 SODIMM.

Design Tools

- Quartus Prime 20.1.1 Standard Edition
- Nios II EDS 20.1.1

Demonstration Source Code

- Project directory: TR4_DDR3_UniPHY_1G_QSYS
- Bit stream used: TR4_DDR3_UniPHY_1G_QSYS.sof
- Nios II Workspace: TR4_DDR3_UniPHY_1G_QSYS\Software

Demonstration Batch File

Demo Batch File Folder: *TR4_DDR3_UniPHY_1G_QSYSdemo_batch*

The demo batch file includes following files:

- Batch File: TR4_DDR3_UniPHY_1G_QSYS.bat, TR4_DDR3_UniPHY_1G_QSYS.sh
- FPGA Configuration File: TR4_DDR3_UniPHY_1G_QSYS.sof
- Nios II Program: TR4_DDR3_UniPHY_1G_QSYS.elf

Demonstration Setup

- Make sure Quartus Prime 20.1.1 Standard Edition and Nios II EDS 20.1.1 are installed on your PC.
- Make sure DDR3-SDRAM SODIMM (1G) is inserted into your TR4 board, as shown in **Figure 5-7**.

- Connect the USB Blaster cable to the TR4 board and host PC. Install the USB Blaster driver if necessary.
- Power on the TR4 board.
- Execute the demo batch file “*TR4_DDR3_UniPHY_1G_QSYS.bat*” under the batch file folder, *TR4_DDR3_UniPHY_1G_QSYSdemo_batch*.
- After Nios II program is downloaded and executed successfully, a prompt message will be displayed in nios2-terminal.
- Press **BUTTON3~BUTTON0** of the TR4 board to start the DDR3 verification process. Press **BUTTON0** to continue the test and **Ctrl+C** to terminate the test
- The program will display the progress and result, as shown in **Figure 5-9**

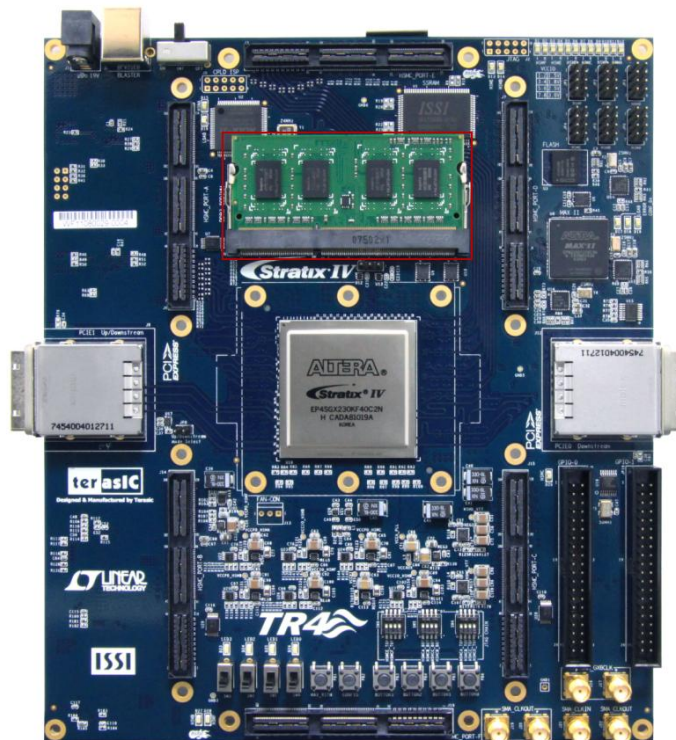

Figure 5-8 Insert the DDR3-SDRAM SODIMM for the DDR3 1G Demonstration

```

C:\intelFPGA\20.1.1\quartus\bin64\nios2-terminal.exe
Info: Elapsed time: 00:00:44
Info: Total CPU time (on all processors): 00:00:06
Using cable "USB-Blaster [USB-0]", device 1, instance 0x00
Resetting and pausing target processor: OK
Initializing CPU cache (if present)
OK
Downloaded 80KB in 1.1s (72.7KB/s)
Verified OK
Waiting to allow other programs to start: done
Starting processor at address 0x41020238
nios2-terminal: connected to hardware target using JTAG UART on cable
nios2-terminal: "USB-Blaster [USB-0]", device 1, instance 0
nios2-terminal: (Use the IDE stop button or Ctrl-C to terminate)

==== TR4 DDR3 Test Program ====
DDR3 Clock: 533 MHZ
DDR3 Size: 1024 MBytes

=====
Press any BUTTON to start test [BUTTON0 for continued test]
====> DDR3 Testing, Iteration: 1
write...
10% 20% 30% 40% 50% 60% 70% 80% 90% 100%
read/verify...
10% 20% 30% 40% 50% 60% 70% 80% 90% 100%
DDR3 test pass, size=1073741824 bytes, 115.941 sec

=====
Press any BUTTON to start test [BUTTON0 for continued test]

```

Figure 5-9 Display Progress and Result for the DDR3 1G Demonstration

5.6 DDR3 SDRAM (4GB)

This demonstration presents user a basic utilization of DDR3-SDRAM (4G) on TR4. It describes how the Altera’s “DDR3 SDRAM Controller with UniPHY” IP is used to create a DDR3-SDRAM controller, and modify the IP-generated example top to test the entire space of DDR3-SDRAM. This demonstration is a pure RTL project. The required DDR3-SDRAM SODIMM module should be exactly 4 GB of DDR3-1066.

Function Block Diagram

Figure 5-9 shows the function block diagram of this demonstration. The DDR3 controller is configured as a 4GB DDR3-1066 controller. The DDR3 IP generates one 533.0 MHz clock as memory clock and one half-rate system clock, 266.5 MHz, for the controller.

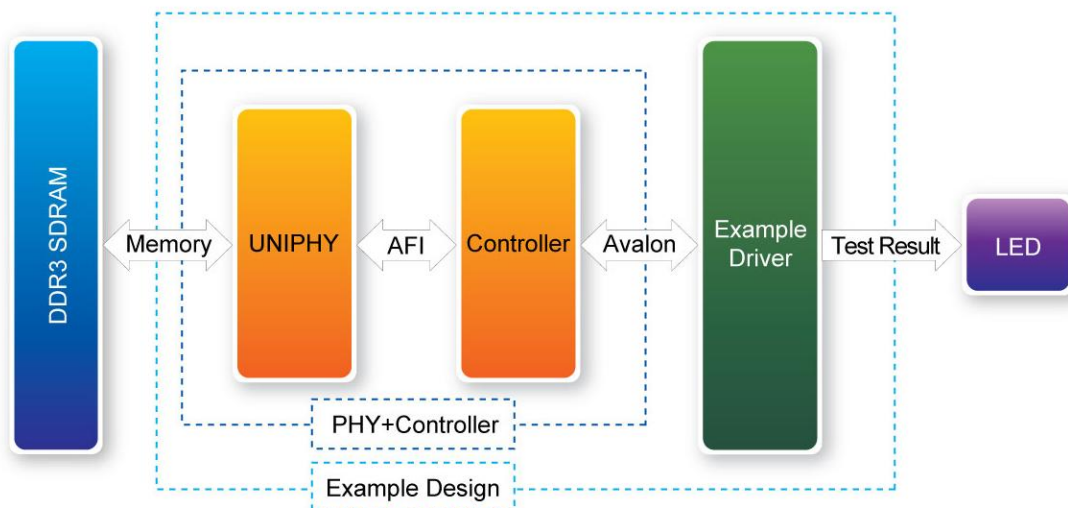

Figure 5-10 Block Diagram of the DDR3 4G Demonstration

The project is based on the example top code which is generated by the DDR3 IP, and can be used to test the whole module after modifying the code. In the project, example driver will read out the data for a comparison after writing every 1KB pseudo-random data. The read compare module will buffer the write data, and then compare it with the data read back. If the right result is achieved, the address will be accumulated and the test will check the whole memory span of 4GB after finishing $4 \times 1024 \times 1024$ loops.

Altera DDR3 SDRAM Controller with UniPHY

To use Altera DDR3 controller, users need to perform three major steps: 1). Create correct pin assignment for DDR3. 2). Setup correct parameters in DDR3 controller dialog. 3). Execute TCL files, generated by DDR3 IP, under your Quartus project.

The following section describes some of the important issues in support of the DDR3 controller configuration. On the “PHY_Setting” tab, in order to achieve 533.0 MHz clock frequency, a reference clock frequency of 50 MHz should be used.

Design Tools

- Quartus Prime 20.1.1 Standard Edition

Demonstration Source Code

- Project directory: TR4_DDR3_UniPHY_4G_RTL
- Bit stream used: TR4_DDR3_UniPHY_4G_RTL.sof

Demonstration Batch File

Demo Batch File Folder: *TR4_DDR3_UniPHY_4G_RTL\demo_batch*

The demo batch file includes following files:

- Batch File: TR4_DDR3_UniPHY_4G_RTL.bat
- FPGA Configure File: TR4_DDR3_UniPHY_4G_RTL.sof

Demonstration Setup

- Make sure Quartus Prime 20.1.1 Standard Edition are installed on your PC.
- Make sure DDR3-SDRAM SODIMM (4 GB) is installed on your TR4 board, as shown in [Figure 5-10](#).
- Connect the USB Blaster cable to the TR4 board and host PC. Install the USB Blaster driver if necessary.
- Power on the TR4 board.
- Execute the demo batch file “*TR4_DDR3_UniPHY_4G_RTL.bat*” under the batch file folder, *TR4_DDR3_UniPHY_4G_RTL\demo_batch*.
- Press **BUTTON0** of the TR4 board to start the verification process. When **BUTTON0** is pressed, all the LEDs go out. At the instant of releasing **BUTTON0**, **LED3** should turn on (local_init_done). After approximately 15 seconds, if **LED0** and **LED1** turn on, the test has passed.
- If **LED2** turns on at any time during the process, the test has failed. [Table 5-3](#) lists the function for different LEDs.
- Press **BUTTON0** to reset the process for a repeat test.

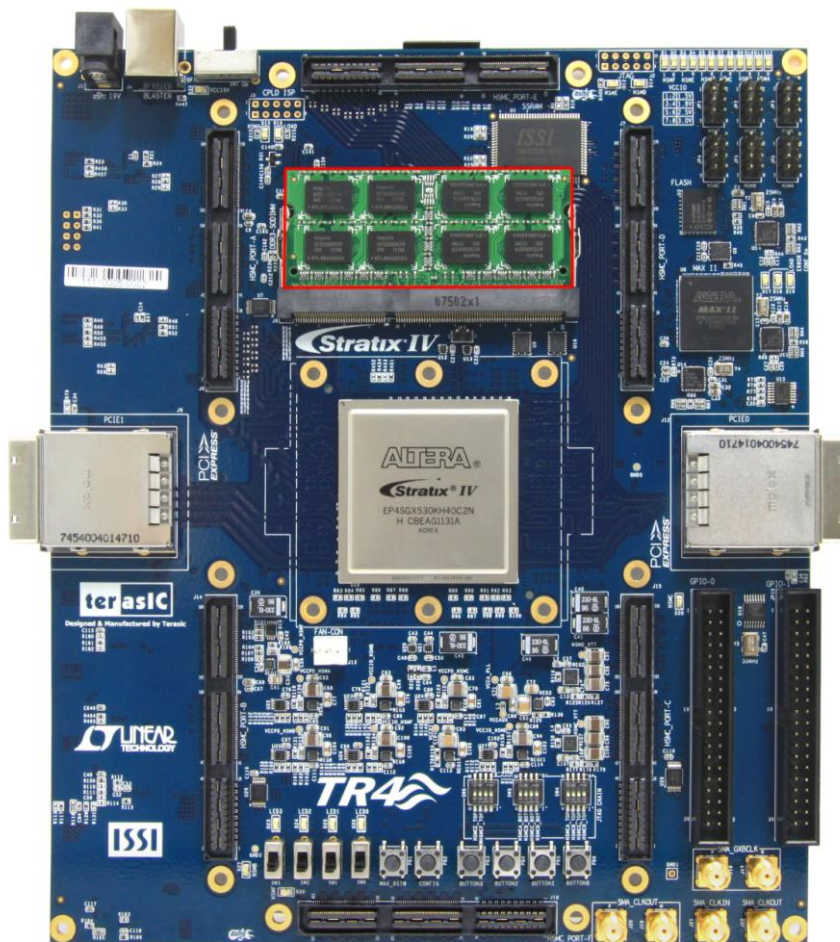

Figure 5-11 Insert DDR3-SDRAM SODIMM for the DDR3 4G Demonstration

Table 5-3 LED Indicators

NAME	Description
LED0	test complete
LED1	test pass
LED2	test fail
LED3	local_init_done & local_cal_success

5.7 SSRAM Test

In this demonstration, hardware and software designs are provided to illustrate how to perform SSRAM memory access in QSYS.

Function Block Diagram

Figure 5-12 shows the System block diagram of this demonstration. The QSYS system requires one 50MHz clock source. There are two Generic Tristate Controllers in this demonstration. One Generic Tri-state Controller is configured as a 1Gb Flash controller and another one is configured as 16Mb SSRAM controller. The Tristate Conduit Pin Sharer multiplexes between the signals of the two connected tri-state controllers. Nios II processor is used to perform memory test. The Nios II program is running on the On-Chip memory.

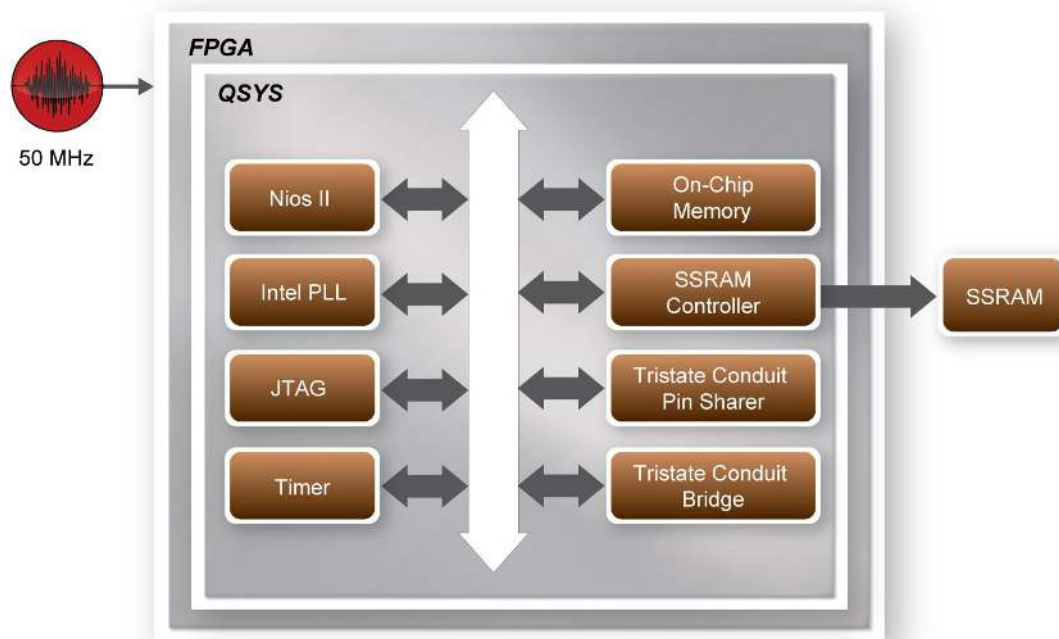

Figure 5-12 Function Block Diagram of the SSRAM Test

The system flow is controlled by a Nios II program. The Nios II program writes test words into the whole size of SSRAM at first. Then, it calls Nios II system function `alt_dcache_flush_all()` to make sure that all data has been written to SSRAM. Finally, it reads back all data from SSRAM for data verification. The program will show the progress in JTAG-Terminal when writing or reading data from or to SSRAM. When verification is completed, the result is displayed in the JTAG-Terminal.

Design Tools

- Quartus Prime 20.1.1 Standard Edition

- Nios II EDS 20.1.1

Demonstration Source Code

- Quartus Prime project directory: TR4_SSRAM
- Nios II Eclipse: TR4_SSRAM\software

Nios Project Compilation

Before you attempt to compile the reference design under Nios II Eclipse, make sure the project is cleaned first by clicking "Clean" from the "Project" menu of Nios II Eclipse.

Demonstration Batch File

Demo Batch File Folder: *TR4_SSRAMdemo_batch*

The demo batch file includes following files:

- Batch file for USB-Blaster II: TR4_SSRAM.bat, TR4_SSRAM.sh
- FPGA configure file: TR4_SSRAM.sof
- Nios II program: mem_test.elf

Demonstration Setup

Please follow below procedures to setup the demonstrations.

- Make sure Quartus Prime 20.1.1 Standard Edition and Nios II EDS 20.1.1 are installed on your PC.
- Power on the FPGA board.
- Use the USB Cable to connect the PC and the FPGA board and install the USB Blaster II driver if necessary.
- Execute the demo batch file "TR4_SSRAM.bat" under the folder TR4_SSRAMdemo_batch
- After the Nios II program is downloaded and executed successfully, a prompt message will be displayed in the nios2-terminal
- The program will display progress and result information, as shown in **Figure 5-13**.

```
C:\intelFPGA\20.1.1\quartus\bin64\nios2-terminal.exe
Info (209060): Started Programmer operation at Fri Dec 25 11:14:33 2020
Info (209016): Configuring device index 1
Info (209017): Device 1 contains JTAG ID code 0x024030DD
Info (209007): Configuration succeeded -- 1 device(s) configured
Info (209011): Successfully performed operation(s)
Info (209061): Ended Programmer operation at Fri Dec 25 11:15:12 2020
Info: Quartus Prime Programmer was successful. 0 errors, 0 warnings
Info: Peak virtual memory: 4916 megabytes
Info: Processing ended: Fri Dec 25 11:15:12 2020
Info: Elapsed time: 00:00:45
Info: Total CPU time (on all processors): 00:00:06
Using cable "USB-Blaster [USB-0]", device 1, instance 0x00
Resetting and pausing target processor: OK
Initializing CPU cache (if present)
OK
Downloaded 91KB in 1.4s (65.0KB/s)
Verified OK
Waiting to allow other programs to start: done
Starting processor at address 0x01240238
nios2-terminal: connected to hardware target using JTAG UART on cable
nios2-terminal: "USB-Blaster [USB-0]", device 1, instance 0
nios2-terminal: (Use the IDE stop button or Ctrl-C to terminate)

SSRAM(2MB) Testing...
write...
10% 20% 30% 40% 50% 60% 70% 80% 90% 100%
read/verify...
10% 20% 30% 40% 50% 60% 70% 80% 90% 100%
Test:Pass
```

Figure 5-13 Function Block Diagram of the SSRAM Test

Chapter 6

PCI Express Reference Design

for Windows

PCI Express is commonly used in consumer, server, and industrial applications, to link motherboard-mounted peripherals. From this demonstration, it will show how the PC Windows and FPGA communicate with each other through the PCI Express interface. IP_Compiler for PCI Express and Modular SGDMA are used in this demonstration. For detail about this Modular SGDMA, please refer to Intel document :

https://www.intel.com/content/dam/altera-www/global/en_US/uploads/5/58/MSGDMA_Docs.zip

6.1 PCI Express System Infrastructure

Figure 6-1 shows the infrastructure of the PCI Express System in this demonstration. It consists of two primary components: FPGA System and PC System. The FPGA System is developed based on IP_Compiler for PCI Express and Modular SGDMA. The application software on the PC side is developed by Terasic based on Intel's PCIe kernel mode driver.

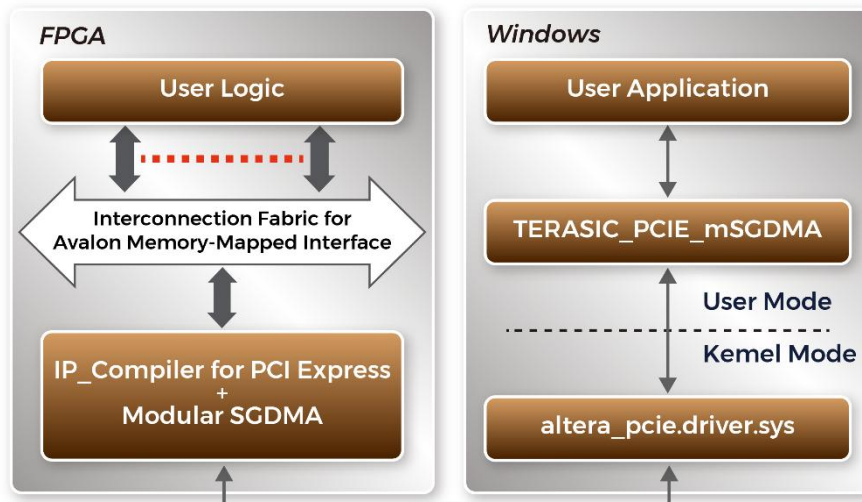

Figure 6-1 PCI Express System Infrastructure

6.2 PC PCI Express Software SDK

The FPGA System CD contains a PC Windows based SDK to allow users to develop their 64-bit software application on 64-bits Windows 10. The SDK is located in the “CDROM \demonstrations\PCIe_SW_KIT\Windows” folder which includes:

- PCI Express Driver
- PCI Express Library
- PCI Express Examples

The kernel mode driver assumes the PCIe vender ID (VID) is 0x1172 and the device ID (DID) is 0xE001. If different VID and DID are used in the design, users need to modify the PCIe vender ID (VID) and device ID (DID) in the driver INF file accordingly.

The PCI Express Library is implemented as a single DLL named *TERASIC_PCIE_mSGDMA.DLL*.

This file is a 64-bit DLL. With the DLL is exported to the software API, users can easily communicate with the FPGA. The library provides the following functions:

- Basic data read and write
- Data read and write by DMA

For high performance data transmission, Intel Modular SGDMA is required as the read and write operations are specified under the hardware design on the FPGA.

6.3 PCI Express Software Stack

Figure 6-2 shows the software stack for the PCI Express application software on 64-bit Windows. The PCI Express driver incorporated in the DLL library is called Terasic_PCIE_mSGDMA.dll. Users can develop their applications based on this DLL. The altera_pcie_win_driver.sys kernel driver is provided by Intel.

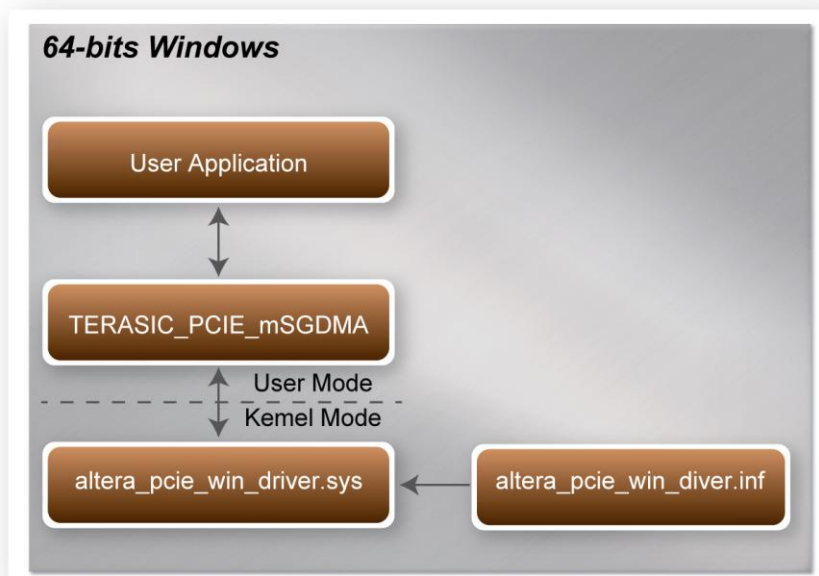

Figure 6-2 PCI Express Software Stack

■ Install PCI Express Driver on Windows

The PCIe driver is located in the folder:

“CDROM\Demonstrations\PCIe_SW_KIT\Windows\PCIe_Driver “

The folder includes the following four files:

- Altera_pcie_win_driver.cat
- Altera_pcie_win_driver.inf
- Altera_pcie_win_driver.sys
- WdfCoinstaller01011.dll

To install the PCI Express driver, please execute the steps below:

1. Make sure TR4 and PC are both powered off.
2. Plug the PCIe adapter card 3 (PCA3) into PCIe slot on the PC motherboard. Use the PCIe cable to connect to the TR4 PCIE0 connector and PCIe adapter card.
3. Power on your TR4 board and host PC
4. Make sure Intel Programmer and USB-Blaster II driver are installed
5. Execute test.bat in “CDROM\demonstrations\tr4_x30\PCIe_Fundamental\demo_batch” to configure the FPGA
6. Restart Windows operation system
7. Click Control Panel menu from Windows Start menu. Click Hardware and Sound item before clicking the Device Manager to launch the Device Manager dialog. There will be a PCI Device item in the dialog, as shown in **Figure 6-3**. Move the mouse cursor to the PCI Device item and right click it to select the **Update Driver Software...** item.

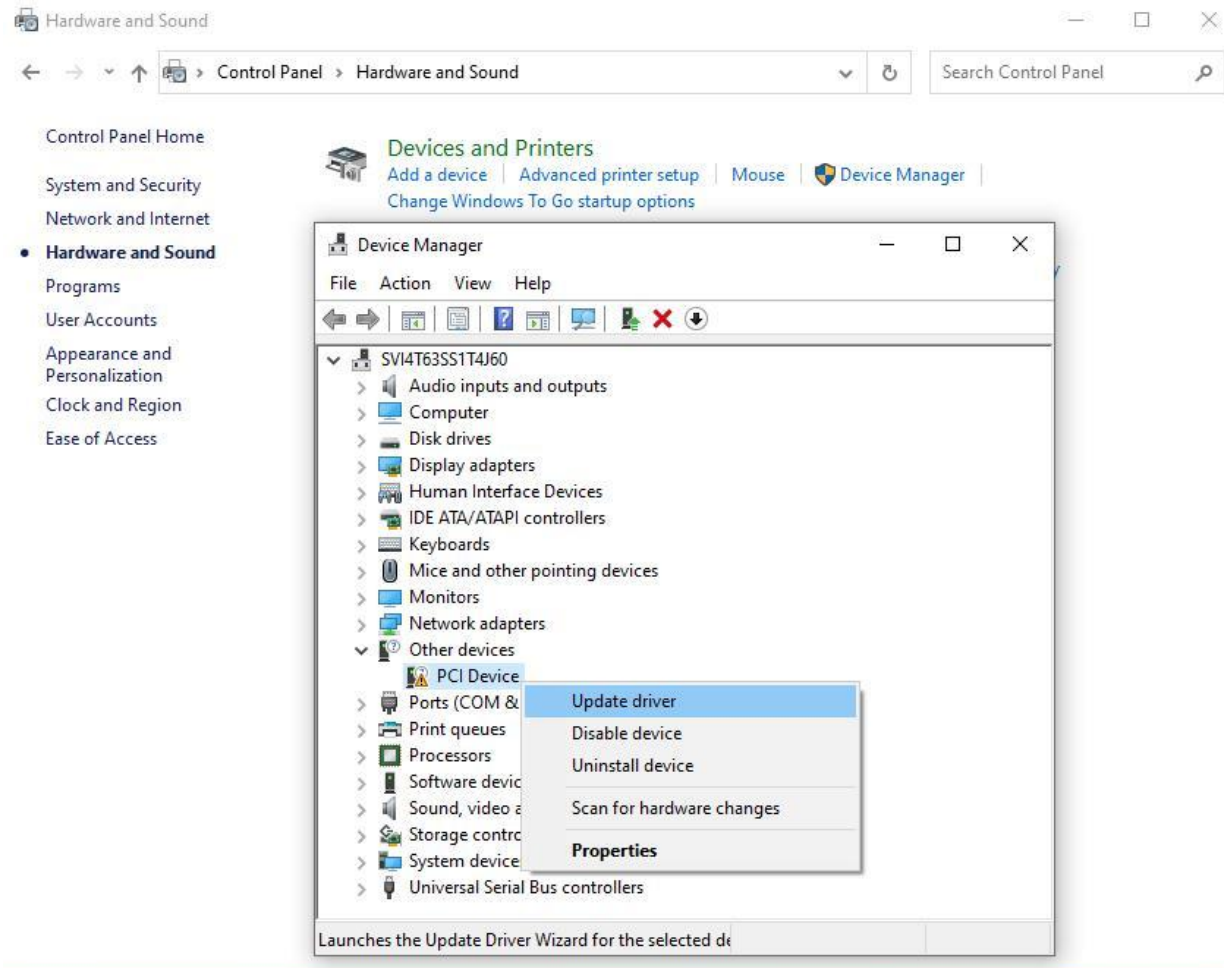

Figure 6-3 Screenshot of launching Update Driver Software... dialog

8. In the **How do you want to search for driver software** dialog, click **Browse my computer for driver software** item, as shown in [Figure 6-4](#).

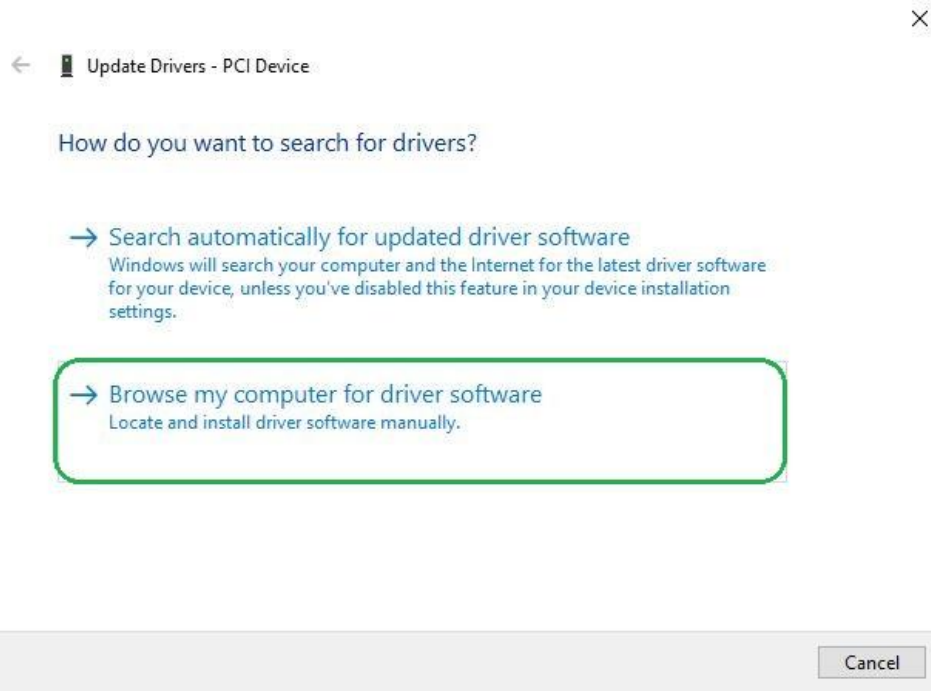

Figure 6-4 Dialog of Browse my computer for driver software

9. In the **Browse for driver software on your computer** dialog, click the **Browse** button to specify the folder where `altera_pcie_din_driver.inf` is located, as shown in [Figure 6-5](#). Click the **Next** button.

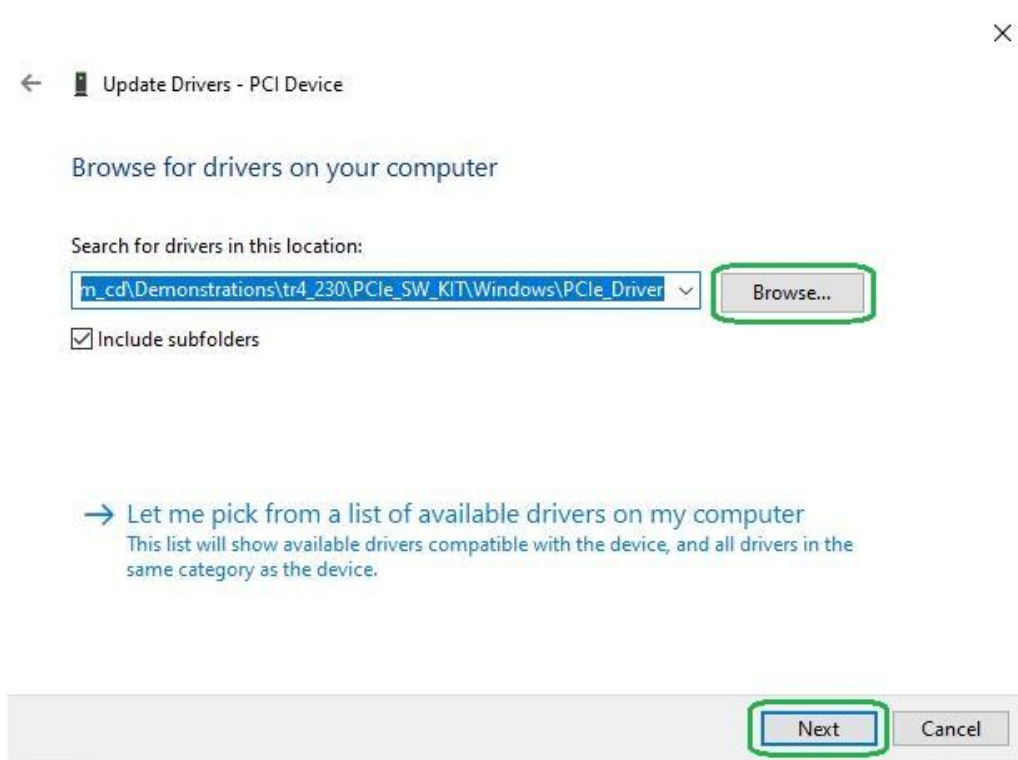

Figure 6-5 Browse for driver software on your computer

10. When the **Windows Security** dialog appears, as shown **Figure 6-6** click the **Install** button.

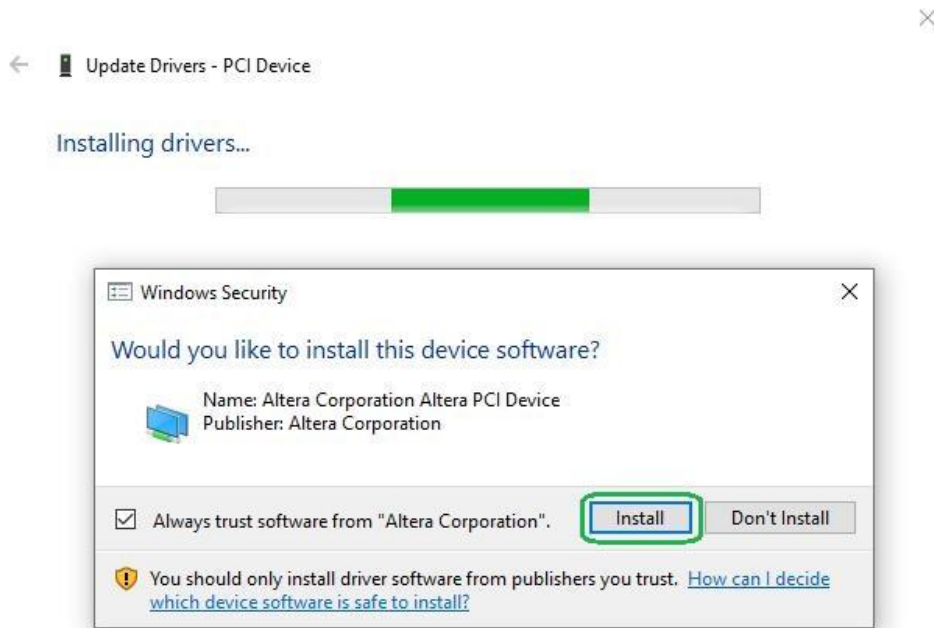

Figure 6-6 Click Install in the dialog of Windows Security

11. When the driver is installed successfully, the successfully dialog will appear, as shown in **Figure 6-7**. Click the **Close** button.

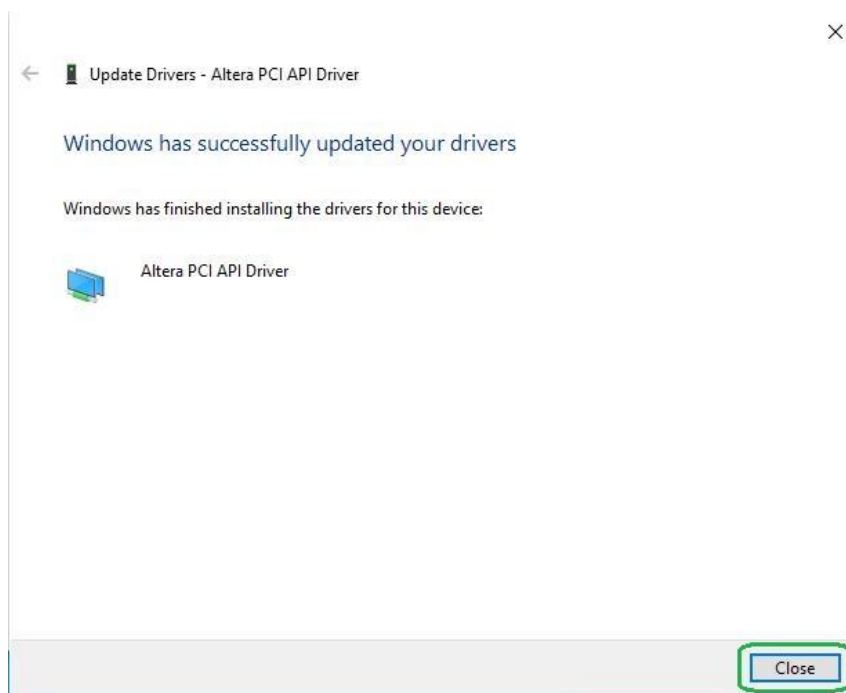

Figure 6-7 Click Close when the installation of PCI Driver is complete

12. Once the driver is successfully installed, users can see the **Altera PCI API Driver** under the device manager window, as shown in **Figure 6-8**.

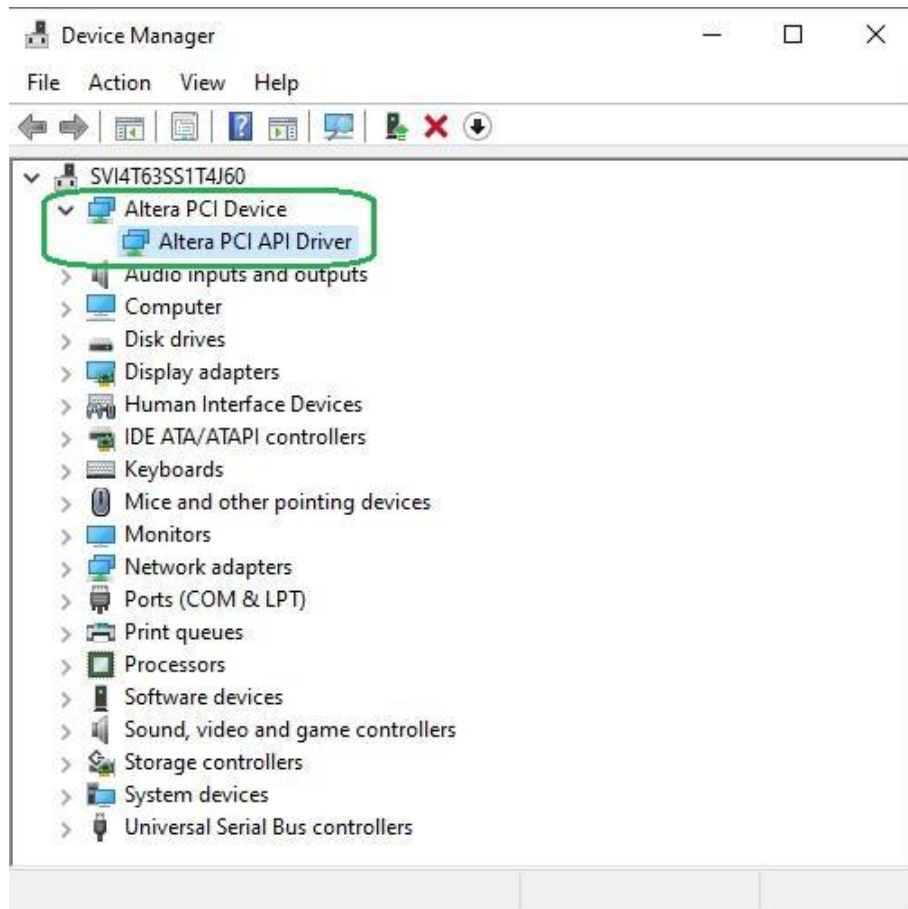

Figure 6-8 Altera PCI API Driver in Device Manager

■ Create a Software Application

All the files needed to create a PCIe software application are located in the directory `CDROM\demonstration\PCIe_SW_KIT\Windows\PCIe_Library`. It includes the following files:

- `TERASIC_PCIE_mSGDMA.h`
- `TERASIC_PCIE_mSGDMA.DLL` (64-bit DLL)

Below lists the procedures to use the SDK files in users' C/C++ project:

1. Create a 64-bit C/C++ project.
2. Include `TERASIC_PCIE_mSGDMA.h` in the C/C++ project.
3. Copy `TERASIC_PCIE_mSGDMA.DLL` to the folder where the `project.exe` is located.

4. Dynamically load Terasic_PCIE_mSGDMA.DLL in C/C++ program. To load the DLL, please refer to the PCIe fundamental example below.
5. Call the SDK API to implement the desired application.

Users can easily communicate with the FPGA through the PCIe bus through the Terasic_PCIE_mSGDMA.DLL API. The details of API are described below section.

6.4 PCI Express Library API

Below shows the exported API in the Terasic_PCIE_MSGDMA.DLL. The API prototype is defined in the Terasic_PCIE_MSGDMA.h.

Note: the Linux library terasic_pcie_qsys.so also use the same API and header file.

■ PCIE_Open

Function:
Open a specified PCIe card with vendor ID, device ID, and matched card index.
Prototype:
<pre>PCIE_HANDLE PCIE_Open(uint8_t wVendorID, uint8_t wDeviceID, uint8_t wCardIndex);</pre>
Parameters:
<p>wVendorID: Specify the desired vendor ID. A zero value means to ignore the vendor ID.</p> <p>wDeviceID: Specify the desired device ID. A zero value means to ignore the device ID.</p> <p>wCardIndex: Specify the matched card index, a zero based index, based on the matched vendor ID and deviceID.</p>
Return Value:
<p>Return a handle to presents specified PCIe card. A positive value is return if the PCIe card is opened successfully. A value zero means failed to connect the target PCIe card.</p> <p>This handle value is used as a parameter for other functions, e.g. PCIE_Read32.</p>

Users need to call PCIE_Close to release handle once the handle is no more used.

■ PCIE_Close

Function:

Close a handle associated to the PCIe card.

Prototype:

```
void PCIE_Close(  
    PCIE_HANDLE hPCIE);
```

Parameters:

hPCIE:
A PCIe handle return by PCIE_Open function.

Return Value:

None.

■ PCIE_Read32

Function:

Read a 32-bit data from the FPGA board.

Prototype:

```
bool PCIE_Read32(  
    PCIE_HANDLE hPCIE,  
    PCIE_BAR PcieBar,  
    PCIE_ADDRESS PcieAddress,  
    uint32_t *pdwData);
```

Parameters:

hPCIE:
A PCIe handle return by PCIE_Open function.

PcieBar:
Specify the target BAR.

PcieAddress:
Specify the target address in FPGA.

pdwData:
A buffer to retrieve the 32-bit data.

Return Value:

Return **true** if read data is successful; otherwise **false** is returned.

■ PCIE_Write32

Function:
Write a 32-bit data to the FPGA Board.
Prototype:
<pre>bool PCIE_Write32(PCIE_HANDLE hPCIE, PCIE_BAR PcieBar, PCIE_ADDRESS PcieAddress, uint32_t dwData);</pre>
Parameters:
<p>hPCIE: A PCIe handle return by PCIE_Open function.</p> <p>PcieBar: Specify the target BAR.</p> <p>PcieAddress: Specify the target address in FPGA.</p> <p>dwData: Specify a 32-bit data which will be written to FPGA board.</p>
Return Value:
Return true if write data is successful; otherwise false is returned.

■ PCIE_Write8

Function:
Write an 8-bit data to the FPGA Board.
Prototype:
<pre>bool PCIE_Write8(PCIE_HANDLE hPCIE, PCIE_BAR PcieBar, PCIE_ADDRESS PcieAddress, uint8_t Byte);</pre>
Parameters:
<p>hPCIE: A PCIe handle return by PCIE_Open function.</p> <p>PcieBar: Specify the target BAR.</p> <p>PcieAddress: Specify the target address in FPGA.</p>

Byte:

Specify an 8-bit data which will be written to FPGA board.

Return Value:

Return **true** if write data is successful; otherwise **false** is returned.

■ PCIE_DmaRead

Function:

Read data from the memory-mapped memory of FPGA board in DMA.

Maximal read size is (4GB-1) bytes.

Prototype:

```
bool PCIE_DmaRead(  
    PCIE_HANDLE hPCIE,  
    PCIE_LOCAL_ADDRESS LocalAddress,  
    void *pBuffer,  
    uint32_t dwBufSize  
);
```

Parameters:

hPCIE:

A PCIe handle return by PCIE_Open function.

LocalAddress:

Specify the target memory-mapped address in FPGA.

pBuffer:

A pointer to a memory buffer to retrieved the data from FPGA. The size of buffer should be equal or larger the dwBufSize.

dwBufSize:

Specify the byte number of data retrieved from FPGA.

Return Value:

Return **true** if read data is successful; otherwise **false** is returned.

■ PCIE_DmaWrite

Function:

Write data to the memory-mapped memory of FPGA board in DMA.

Prototype:

```
bool PCIE_DmaWrite(  
    PCIE_HANDLE hPCIE,
```

```
PCIE_LOCAL_ADDRESS LocalAddress,  
void *pData,  
uint32_t dwDataSize  
);
```

Parameters:

hPCIE:

A PCIe handle return by PCIE_Open function.

LocalAddress:

Specify the target memory mapped address in FPGA.

pData:

A pointer to a memory buffer to store the data which will be written to FPGA.

dwDataSize:

Specify the byte number of data which will be written to FPGA.

Return Value:

Return **true** if write data is successful; otherwise **false** is returned.

■ PCIE_ConfigRead32

Function:

Read PCIe Configuration Table. Read a 32-bit data by given a byte offset.

Prototype:

```
bool PCIE_ConfigRead32 (  
    PCIE_HANDLE hPCIE,  
    uint32_t Offset,  
    uint32_t *pdwData  
);
```

Parameters:

hPCIE:

A PCIe handle return by PCIE_Open function.

Offset:

Specify the target byte of offset in PCIe configuration table.

pdwData:

A 4-bytes buffer to retrieve the 32-bit data.

Return Value:

Return **true** if read data is successful; otherwise **false** is returned.

■ PCIE_ConfigRead8

Function:

Read PCIe Configuration Table. Read a 8-bit data by given a byte offset.

Prototype:

```
bool PCIE_ConfigRead8 (  
    PCIE_HANDLE hPCIE,  
    uint32_t Offset,  
    uint8_t *pByte  
);
```

Parameters:

hPCIE:

A PCIe handle return by PCIE_Open function.

Offset:

Specify the target byte of offset in PCIe configuration table.

pByte:

A 1-bytes buffer to retrieve the 8-bit data.

Return Value:

Return **true** if read data is successful; otherwise **false** is returned.

6.5 PCIe Reference Design - Fundamental

The application reference design shows how to implement fundamental control and data transfer in DMA. In the design, basic I/O is used to control the BUTTON and LED on the FPGA board. High-speed data transfer is performed by DMA.

■ Demonstration Files Location

The demo file is located in the batch folder:

CDROM\demonstrations\TR4_x30\PCIE_Fundamental\demo_batch

The folder includes following files:

- FPGA Configuration File: PCIE_Fundamental.sof

- Download Batch file: test.bat
- Windows Application Software folder : windows_app, includes
 - PCIE_FUNDAMENTAL.exe
 - TERASIC_PCIE_mSGDMA.dll

■ Demonstration Setup

The demo file is located in the batch folder:

1. Use the PCIe cable to connect to the TR4 PCIE0 connector and PCIe adapter card 3 (PCA3) as shown in **Figure 6-9**.

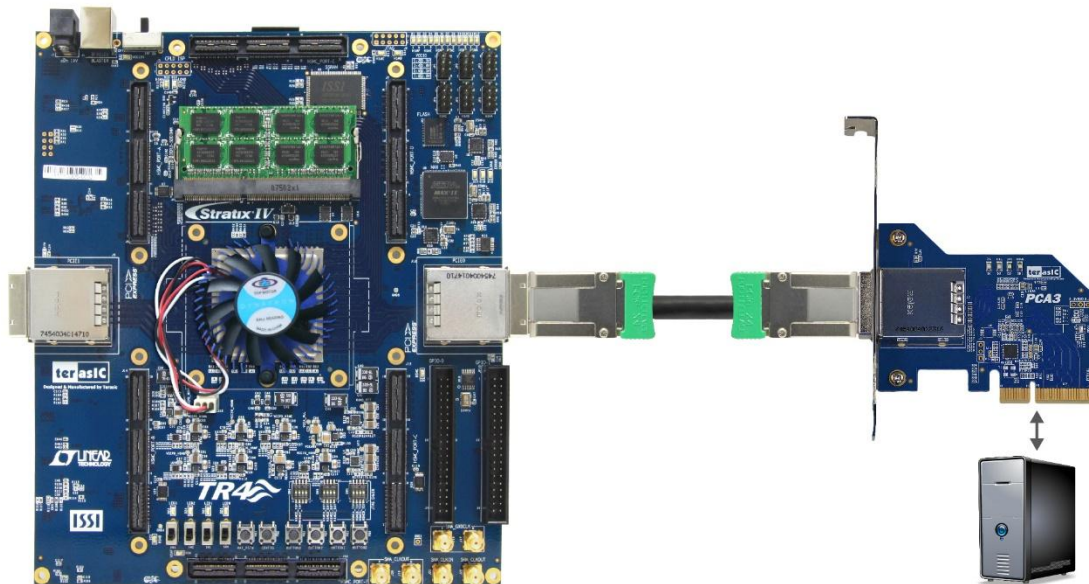

Figure 6-9 FPGA board connect to PC

2. Configure FPGA with PCIe_Fundamental.sof by executing the test.bat.
3. Install PCIe driver if necessary. The driver is located in the folder:

CDROM\Demonstration\PCie_SW_KIT\Windows\PCie_Driver.

4. Make sure the Windows has detected the FPGA Board by checking the Windows Control panel as shown in **Figure 6-10**.

5. Restart Windows

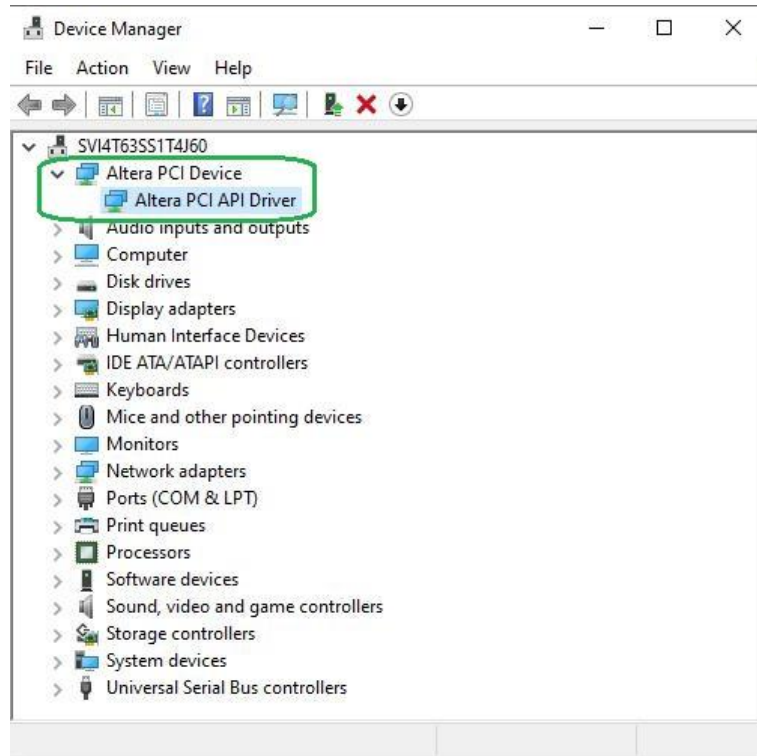

Figure 6-10 Screenshot for PCIe Driver

6. Goto windows_app folder, execute PCIE_FUNDAMENTAL.exe. A menu will appear as shown in Figure 6-11.

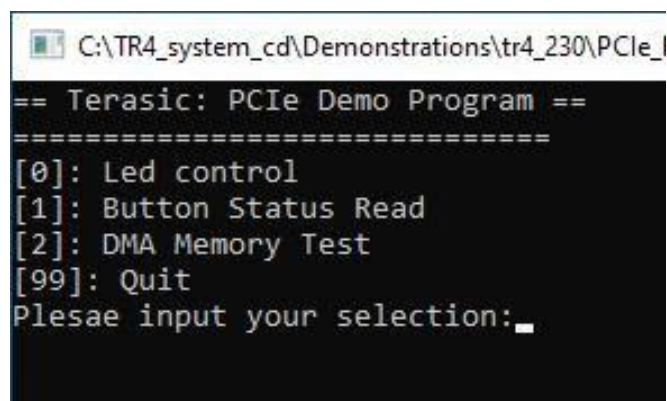
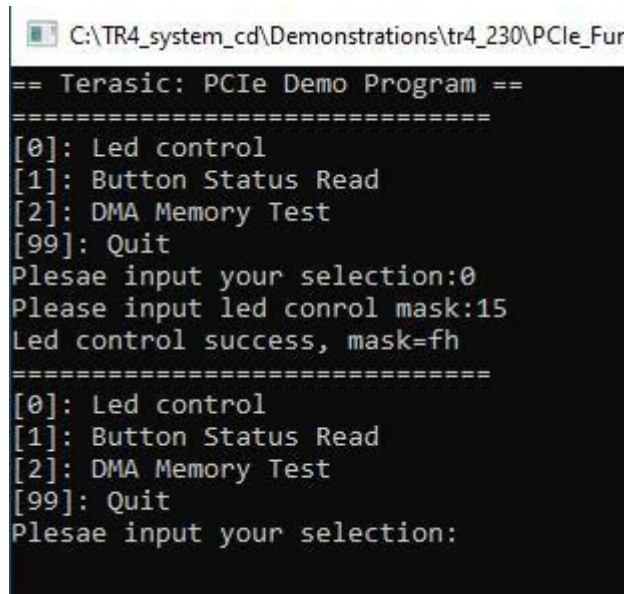

Figure 6-11 Screenshot of Program Menu

7. Type 0 followed by a ENTERY key to select Led Control item, then input 15(hex 0x0f) will

make all led on as shown in **Figure 6-12**. If input 0(hex 0x00), all led will be turn off.



```
C:\TR4_system_cd\Demonstrations\tr4_230\PCIe_Fur
== Terasic: PCIe Demo Program ==
=====
[0]: Led control
[1]: Button Status Read
[2]: DMA Memory Test
[99]: Quit
Plesae input your selection:0
Please input led conrol mask:15
Led control success, mask=fh
=====
[0]: Led control
[1]: Button Status Read
[2]: DMA Memory Test
[99]: Quit
Plesae input your selection:
```

Figure 6-12 Screenshot of LED Control

8. Type 1 followed by an ENTER key to select Button Status Read item. The button status will be report as shown in **Figure 6-13**.

```
C:\TR4_system_cd\Demonstrations\tr4_230\PCIe_I
== Terasic: PCIe Demo Program ==
=====
[0]: Led control
[1]: Button Status Read
[2]: DMA Memory Test
[99]: Quit
Plesae input your selection:0
Please input led control mask:15
Led control success, mask=fh
=====
[0]: Led control
[1]: Button Status Read
[2]: DMA Memory Test
[99]: Quit
Plesae input your selection:1
Button status mask:=0h
=====
[0]: Led control
[1]: Button Status Read
[2]: DMA Memory Test
[99]: Quit
Plesae input your selection:_
```

Figure 6-13 Screenshot of Button Status Report

9. Type 2 followed by an ENTER key to select DMA Testing item. The DMA test result will be report as shown in **Figure 6-14**.

```
C:\TR4_system_cd\Demonstrations\tr4_230\PCie_Fi
== Terasic: PCIe Demo Program ==
=====
[0]: Led control
[1]: Button Status Read
[2]: DMA Memory Test
[99]: Quit
Plesae input your selection:0
Please input led conrol mask:15
Led control success, mask=fh
=====
[0]: Led control
[1]: Button Status Read
[2]: DMA Memory Test
[99]: Quit
Plesae input your selection:1
Button status mask:=0h
=====
[0]: Led control
[1]: Button Status Read
[2]: DMA Memory Test
[99]: Quit
Plesae input your selection:2
DMA-Memory (Size = 524288 bytes) pass
=====
[0]: Led control
[1]: Button Status Read
[2]: DMA Memory Test
[99]: Quit
Plesae input your selection:
```

Figure 6-14 Screenshot of DMA Memory Test Result

10. Type 99 followed by an ENTER key to exit this test program.

■ Development Tools

- Quartus Prime 20.1.1 Standard Edition
- Visual C++ 2012

■ Demonstration Source Code Location

- Quartus Project: Demonstrations\TR4_x30\PCie_Fundamental
- C++ Project:
Demonstration\tr4_x30\PCie_SW_KIT\Linux\PCIE_FUNDAMENTAL

■ FPGA Application Design

Figure 6-15 shows the system block diagram in the FPGA system. In the Qsys, PIO controller is used to control the LED and monitor the Button Status, and the On-Chip memory is used for performing DMA testing. The PIO controllers and the On-Chip memory are connected to the PCI Express Hard IP controller through the Memory-Mapped Interface.

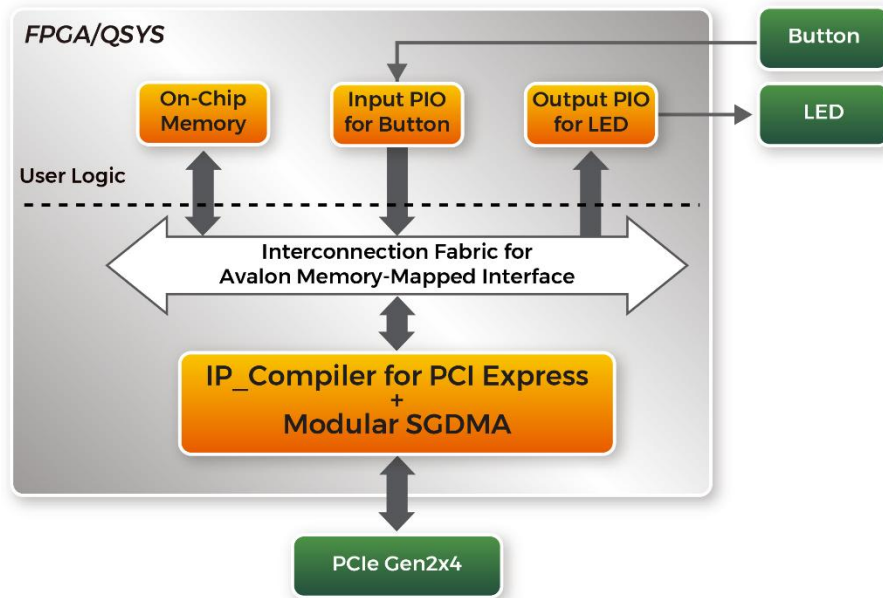

Figure 6-15 Hardware block diagram of the PCIe reference design

■ Windows Based Application Software Design

The application software project is built by Visual C++ 2012. The project includes the following major files:

Name	Description
PCIE_FUNDAMENTAL.cpp	Main program
PCIE.c	Implement dynamically load for TERAISC_PCIE_mSGDMA.DLL
PCIE.h	
TERASIC_PCIE_mSGDMA.h	SDK library file, defines constant and data structure

The main program PCIE_FUNDAMENTAL.cpp includes the header file "PCIE.h" and defines the controller address according to the FPGA design.

```

#include "PCIE.h"

#define DEMO_PCIE_USER_BAR          PCIE_BAR4
#define DEMO_PCIE_IO_LED_ADDR       0x4000010
#define DEMO_PCIE_IO_BUTTON_ADDR    0x4000020
#define DEMO_PCIE_MEM_ADDR          0x07000000

#define MEM_SIZE                     (512*1024) //512KB

```

The base address of BUTTON and LED controllers are 0x4000010 and 0x4000020 based on PCIE_BAR4, in respectively. The on-chip memory base address is 0x07000000 relative to the DMA controller.

Before accessing the FPGA through PCI Express, the application first calls *PCIE_Load* to dynamically load the *TERASIC_PCIE_mSGDMA.DLL*. Then, it calls *PCIE_Open* to open the PCI Express driver. The constant *DEFAULT_PCIE_VID* and *DEFAULT_PCIE_DID* used in *PCIE_Open* are defined in *TERASIC_PCIE_mSGDMA.h*. If developer change the Vender ID and Device ID and PCI Express IP, they also need to change the ID value define in *TERASIC_PCIE_mSGDMA.h*. If the return value of *PCIE_Open* is zero, it means the driver cannot be accessed successfully. In this case, please make sure:

- The FPGA is configured with the associated bit-stream file and the host is rebooted.
- The PCI express driver is loaded successfully.

The LED control is implemented by calling PCIE_Write32 API, as shown below:

```
bPass = PCIE_Write32(hPCIE, DEMO_PCIE_USER_BAR, DEMO_PCIE_IO_LED_ADDR, (uint32_t) Mask);
```

The button status query is implemented by calling the PCIE_Read32 API, as shown below:

```
PCIE_Read32(hPCIE, DEMO_PCIE_USER_BAR, DEMO_PCIE_IO_BUTTON_ADDR, &Status);
```

The memory-mapped memory read and write test is implemented by PCIE_DmaWrite and PCIE_DmaRead API, as shown below:

```
PCIE_DmaWrite(hPCIE, LocalAddr, pWrite, nTestSize);
PCIE_DmaRead(hPCIE, LocalAddr, pRead, nTestSize);
```

6.6 PCIe Reference Design – DDR3

The application reference design shows how to add DDR3 Memory Controllers for DDR3 SODIMM into the PCIe Quartus project based on the PCIe_Fundamental Quartus project and perform 1GB data DMA for both SODIMM. Also, this demo shows how to call “PCIE_ConfigRead32” API to check PCIe link status.

■ Demonstration Files Location

The demo file is located in the batch folder:

CDROM\demonstrations\TR4_x30\PCIe_DDR3\demo_batch

The folder includes following files:

- FPGA Configuration File: PCIe_DDR3.sof
- Download Batch file: test.bat
- Windows Application Software folder : windows_app, includes
 - PCIE_DDR3.exe
 - TERASIC_PCIE_mSGDMA.dll

■ Demonstration Setup

The demo file is located in the batch folder:

1. Install both DDR3 1066 1GB SODIMM on the FPGA board.
2. Install the FPGA board on your PC.
3. Configure FPGA with PCIe_DDR3.sof by executing the test.bat.
4. Restart Windows
5. Install PCIe driver if necessary.
6. Make sure the Windows has detected the FPGA Board by checking the Windows Control panel.
7. Goto windows_app folder, execute PCIE_DDR3.exe. A menu will appear as shown in **Figure 6-16**.

```
C:\TR4_system_cd\Demonstrations\tr4_230\PCIE_
== Terasic: PCIe Demo Program ==
=====
[0]: Led control
[1]: Button Status Read
[2]: Link Info
[3]: DMA On-Chip Memory Test
[4]: DMA DDR3 Sodimm Memory Test
[99]: Quit
Plesae input your selection:
```

Figure 6-16 Screenshot of Program Menu

8. Type 2 followed by an ENTER key to select Link Info item. The PCIe link information will be shown as in **Figure 6-17**. Gen2 link speed and x4 link width are expected.

```
C:\TR4_system_cd\Demonstrations\tr4_230\PCIE_D
=====
[0]: Led control
[1]: Button Status Read
[2]: Link Info
[3]: DMA On-Chip Memory Test
[4]: DMA DDR3 Sodimm Memory Test
[99]: Quit
Plesae input your selection:1
Button status mask:=0h
=====
[0]: Led control
[1]: Button Status Read
[2]: Link Info
[3]: DMA On-Chip Memory Test
[4]: DMA DDR3 Sodimm Memory Test
[99]: Quit
Plesae input your selection:2
Vender ID:1172h
Device ID:E001h
Current Link Speed is Gen2
Negotiated Link Width is x4
Maximum Payload Size is 128-byte
=====
[0]: Led control
[1]: Button Status Read
[2]: Link Info
[3]: DMA On-Chip Memory Test
[4]: DMA DDR3 Sodimm Memory Test
[99]: Quit
Plesae input your selection:
```

Figure 6-17 Screenshot of Link Info

9. Type 3 followed by an ENTER key to select DMA On-Chip Memory Test item. The DMA write and read test result will be report as shown in **Figure 6-18**.

```
C:\TR4_system_cd\Demonstrations\tr4_230\PCIE_DDR3\demo_batch\windows_app\PCIE
[4]: DMA DDR3 Sodimm Memory Test
[99]: Quit
Plesae input your selection:2
Vender ID:1172h
Device ID:E001h
Current Link Speed is Gen2
Negotiated Link Width is x4
Maximum Payload Size is 128-byte
=====
[0]: Led control
[1]: Button Status Read
[2]: Link Info
[3]: DMA On-Chip Memory Test
[4]: DMA DDR3 Sodimm Memory Test
[99]: Quit
Plesae input your selection:3
DMA Memory Test, Address = 0x7000000, Size = 0x80000 Bytes...
Generate Test Pattern...
DMA Write...
DMA Read...
Readback Data Verify...
DMA-Memory Address = 0x7000000, Size = 0x80000 bytes pass
=====
[0]: Led control
[1]: Button Status Read
[2]: Link Info
[3]: DMA On-Chip Memory Test
[4]: DMA DDR3 Sodimm Memory Test
[99]: Quit
Plesae input your selection:
```

Figure 6-18 Screenshot of On-Chip Memory DMA Test Result

10. Type 4 followed by an ENTER key to select DMA DDR3 SODIMM Memory Test item. The DMA write and read test result will be report as shown in **Figure 6-19**.

```
C:\TR4_system_cd\Demonstrations\tr4_230\PCIE_DDR3\demo_batch\windows_app\PCIE_DDR3.e
[99]: Quit
Plesae input your selection:3
DMA Memory Test, Address = 0x7000000, Size = 0x80000 Bytes...
Generate Test Pattern...
DMA Write...
DMA Read...
Readback Data Verify...
DMA-Memory Address = 0x7000000, Size = 0x80000 bytes pass
=====
[0]: Led control
[1]: Button Status Read
[2]: Link Info
[3]: DMA On-Chip Memory Test
[4]: DMA DDR3 Sodimm Memory Test
[99]: Quit
Plesae input your selection:4
DMA Memory Test, Address = 0x40000000, Size = 0x40000000 Bytes...
Generate Test Pattern...
DMA Write...
DMA Read...
Readback Data Verify...
DMA-Memory Address = 0x40000000, Size = 0x40000000 bytes pass
=====
[0]: Led control
[1]: Button Status Read
[2]: Link Info
[3]: DMA On-Chip Memory Test
[4]: DMA DDR3 Sodimm Memory Test
[99]: Quit
Plesae input your selection: _
```

Figure 6-19 Screenshot of DDR3 SOSIMM Memory DMA Test Result

11. Type 99 followed by an ENTERY key to exit this test program.

■ Development Tools

- Quartus Prime 20.1.1 Standard Edition
- Visual C++ 2012

■ Demonstration Source Code Location

- Quartus Project: Demonstrations\TR4_x30\PCIE_DDR3
- Visual C++ Project: Demonstrations\tr4_x30\PCIE_SW_KIT\Windows\PCIE_DDR3

■ FPGA Application Design

Figure 6-20 shows the system block diagram in the FPGA system. In the Qsys, PIO controller is used to control the LED and monitor the Button Status, and the On-Chip memory is used for performing DMA testing. The PIO controllers and the On-Chip memory are connected to the PCI Express Hard IP controller through the Memory-Mapped Interface.

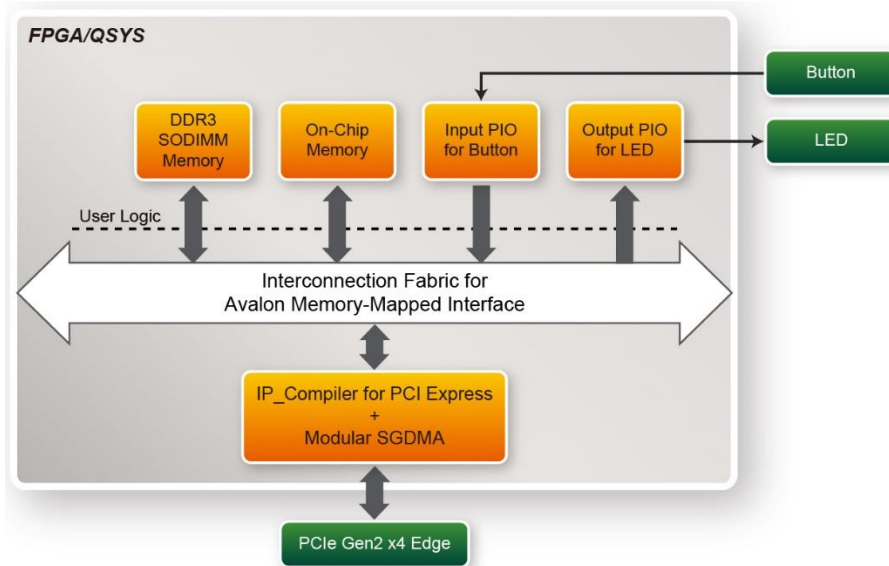

Figure 6-20 Hardware block diagram of the PCIe_DDR3 reference design

■ Windows Based Application Software Design

The application software project is built by Visual C++ 2012. The project includes the following major files:

Name	Description
PCIE_DDR3.cpp	Main program
PCIE.c	Implement dynamically load for TERAISC_PCIE_mSGDMA.DLL
PCIE.h	
TERASIC_PCIE_mSGDMA.h	SDK library file, defines constant and data structure

The main program PCIE_DDR3.cpp includes the header file "PCIE.h" and defines the controller address according to the FPGA design.

```

#define DEMO_PCIE_USER_BAR          PCIE_BAR4
#define DEMO_PCIE_IO_LED_ADDR       0x4000010
#define DEMO_PCIE_IO_BUTTON_ADDR    0x4000020
#define DEMO_PCIE_ONCHIP_MEM_ADDR   0x07000000
#define DEMO_PCIE_DDR3_MEM_ADDR     0x40000000

#define ONCHIP_MEM_TEST_SIZE        (512*1024) //512KB
#define DDR3_MEM_TEST_SIZE          (1*1024*1024*1024) //1GB
#define DMA_CHUNK_SIZE              (1*1024*1024*1024) //1GB

```

The base address of BUTTON and LED controllers are 0x4000010 and 0x4000020 based on PCIE_BAR4, in respectively. The on-chip memory base address is 0x07000000 relative to the DMA controller. **The above definition is the same as those in PCIE_Fundamental demo.**

Before accessing the FPGA through PCI Express, the application first calls PCIE_Load to dynamically load the Terasic_PCIE_mSGDMA.DLL. Then, it call PCIE_Open to open the PCI Express driver. The constant DEFAULT_PCIE_VID and DEFAULT_PCIE_DID used in PCIE_Open are defined in Terasic_PCIE_mSGDMA.h. If developer change the Vender ID and Device ID and PCI Express IP, they also need to change the ID value define in Terasic_PCIE_mSGDMA.h. If the return value of PCIE_Open is zero, it means the driver cannot be accessed successfully. In this case, please make sure:

- The FPGA is configured with the associated bit-stream file and the host is rebooted.
- The PCI express driver is loaded successfully.

The LED control is implemented by calling PCIE_Write32 API, as shown below:

```
bPass = PCIE_Write32(hPCIE, DEMO_PCIE_USER_BAR, DEMO_PCIE_IO_LED_ADDR, (uint32_t) Mask);
```

The button status query is implemented by calling the PCIE_Read32 API, as shown below:

```
PCIE_Read32(hPCIE, DEMO_PCIE_USER_BAR, DEMO_PCIE_IO_BUTTON_ADDR, &Status);
```

The memory-mapped memory read and write test is implemented by PCIE_DmaWrite and PCIE_DmaRead API, as shown below:

```
PCIE_DmaWrite(hPCIE, LocalAddr, pWrite, nTestSize);
PCIE_DmaRead(hPCIE, LocalAddr, pRead, nTestSize);
```

The pcie link information is implemented by PCIE_ConfigRead32 API, as shown below:

```
// read config - link status
if (PCIE_ConfigRead32(hPCIE, 0x90, &Data32)){
    switch((Data32 >> 16) & 0x0F){
        case 1:
            printf("Current Link Speed is Gen1\r\n");
            break;
        case 2:
            printf("Current Link Speed is Gen2\r\n");
            break;
        case 3:
            printf("Current Link Speed is Gen3\r\n");
            break;
        default:
            printf("Current Link Speed is Unknown\r\n");
            break;
    }
    switch((Data32 >> 20) & 0x3F){
        case 1:
            printf("Negotiated Link Width is x1\r\n");
            break;
        case 2:
            printf("Negotiated Link Width is x2\r\n");
            break;
        case 4:
            printf("Negotiated Link Width is x4\r\n");
            break;
        case 8:
            printf("Negotiated Link Width is x8\r\n");
            break;
        case 16:
            printf("Negotiated Link Width is x16\r\n");
            break;
        default:
            printf("Negotiated Link Width is Unknown\r\n");
            break;
    }
}
else{
    bPass = false;
}
```

Chapter 7

PCI Express Reference Design

for Linux

PCI Express is commonly used in consumer, server, and industrial applications, to link motherboard-mounted peripherals. From this demonstration, it will show how the PC Linux and FPGA communicate with each other through the PCI Express interface. IP_Compiler for PCI Express and Modular SGDMA are used in this demonstration. For detail about this Modular SGDMA, please refer to Intel document :

https://www.intel.com/content/dam/altera-www/global/en_US/uploads/5/58/MSGDMA_Docs.zip

7.1 PCI Express System Infrastructure

Figure 7-1 shows the infrastructure of the PCI Express System in this demonstration. It consists of two primary components: FPGA System and PC System. The FPGA System is developed based on IP_Compiler for PCI Express and Modular SGDMA. The application software on the PC side is developed by Terasic based on Intel's PCIe kernel mode driver.

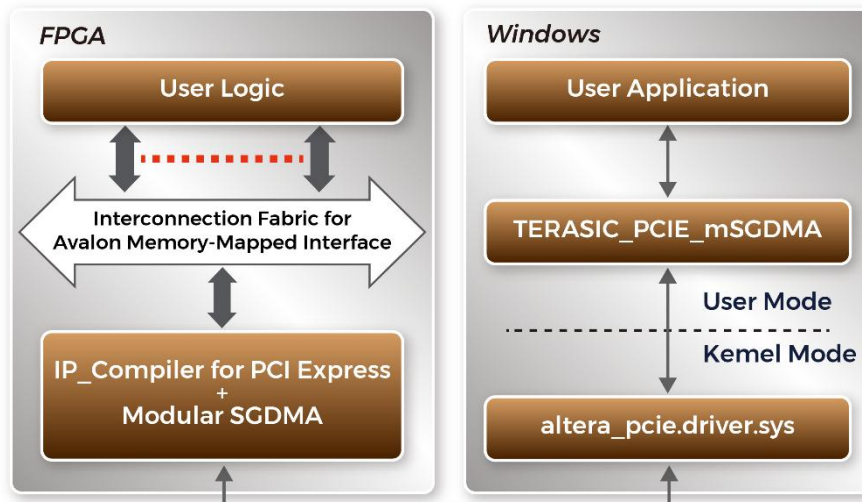

Figure 7-1 PCI Express System Infrastructure

7.2 PC PCI Express Software SDK

The FPGA System CD contains a PC Linux based SDK to allow users to develop their 64-bit software application on 64-bit Linux. CentOS 7.2 is recommended. The SDK is located in the CDROM\Demonstration\PCIe_SW_KIT\Linux folder which includes:

- PCI Express Driver
- PCI Express Library
- PCI Express Examples

The kernel mode driver assumes the PCIe vender ID (VID) is 0x1172 and the device ID (DID) is 0xE001. If different VID and DID are used in the design, users need to modify the PCIe vender ID (VID) and device ID (DID) in the driver INF file accordingly.

The PCI Express Library is implemented as a single DLL named *TERASIC_PCIE_mSGDMA.DLL*.

This file is a 64-bit DLL. With the DLL is exported to the software API, users can easily communicate with the FPGA. The library provides the following functions:

- Basic data read and write
- Data read and write by DMA

For high performance data transmission, Intel Modular SGDMA is required as the read and write operations are specified under the hardware design on the FPGA.

7.3 PCI Express Software Stack

Figure 7-2 shows the software stack for the PCIe application software on 64-bit Linux. The PCIe driver included in the library is `terasic_pcie_msgdma.so`. Users can develop their applications based on this `.so` library file. The `altera_pcie.ko` kernel driver is provided by Intel.

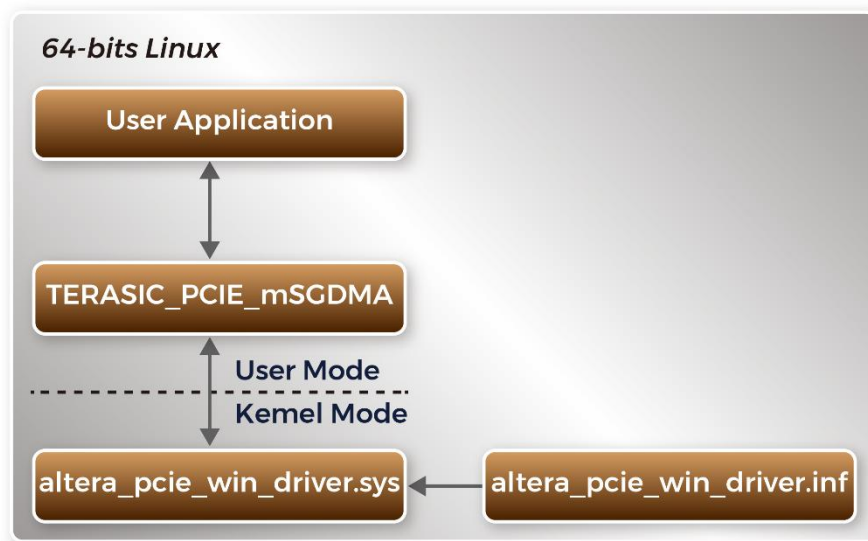

Figure 7-2 PCI Express Software Stack

■ Install PCI Express Driver on Linux

The PCIe driver project is located in the folder:

“CDROM/Demonstration/PCIe_SW_KIT/Linux/PCIe_Driver”

The folder includes the following files:

- `altera_pcie.c`
- `altera_pcie.h`
- `altera_pcie_cmd.h`
- `Makefile`

- load_driver
- unload
- config_file

To install the PCI Express driver, please execute the steps below:

1. Make sure TR4 and PC are both powered off.
2. Plug the PCIe adapter card 3 (PCA3) into PCIe slot on the PC motherboard. Use the PCIe cable to connect to the TR4 PCIE0 connector and PCIe adapter card.
3. Power on your TR4 board and host PC
4. Make sure Intel Programmer and USB-Blaster II driver are installed
5. Execute test.bat in “CDROM\demonstrations\tr4_x30\PCIe_Fundamental\demo_batch” to configure the FPGA.
6. Set QUARTUS_ROOTDIR variable pointing to the Quartus installation path. Set QUARTUS_ROOTDIR variable by typing the following commands in the terminal. Replace “/home/centos/intelFPGA/20.1/quartus/” to your quartus installation path.

```
export QUARTUS_ROOTDIR=/home/centos/intelFPGA/20.1/quartus/
```

7. Execute "sudo -E sh test.sh" command to configure the FPGA.
8. Restart the Linux operation system. In Linux, open a terminal and use “cd” command to goto the PCIe_Driver folder.
9. Type the following commands to compile and install the driver altera_pcie.ko, and make sure driver is loaded successfully and FPGA is detected by the driver as shown in Figure 7-3.
 - make
 - sudo sh load_driver
 - dmesg | tail -n 15

```

centos@localhost:PCie_Driver$ sudo sh load_driver
Matching Device Found
centos@localhost:PCie_Driver$ dmesg | tail -n 15
[ 33.606870] usb 3-5: reset high-speed USB device number 4 using xhci_hcd
[ 611.592676] Altera PCIE: altera_pcie_init(), Mar  5 2018 13:58:03
[ 611.592695] Altera PCIE 0000:01:00.0: enabling device (0000 -> 0002)
[ 611.592744] Altera PCIE 0000:01:00.0: pci_enable_device() successful
[ 611.592765] Altera PCIE 0000:01:00.0: irq 34 for MSI/MSI-X
[ 611.592770] Altera PCIE 0000:01:00.0: pci_enable_msi() successful
[ 611.592772] Altera PCIE 0000:01:00.0: BAR[0] 0xe0000000-0xe7ffffff flags 0x0014220c, length 134217728
[ 611.592773] Altera PCIE 0000:01:00.0: BAR[1] 0x00000000-0x00000000 flags 0x00000000, length 0
[ 611.592774] Altera PCIE 0000:01:00.0: BAR[2] 0xd8000000-0xdfffffff flags 0x0014220c, length 134217728
[ 611.592775] Altera PCIE 0000:01:00.0: BAR[3] 0x00000000-0x00000000 flags 0x00000000, length 0
[ 611.592776] Altera PCIE 0000:01:00.0: BAR[4] 0xd0000000-0xd7ffffff flags 0x0014220c, length 134217728
[ 611.592776] Altera PCIE 0000:01:00.0: BAR[5] 0x00000000-0x00000000 flags 0x00000000, length 0
[ 611.592790] Altera PCIE 0000:01:00.0: BAR[0] mapped to 0xfffffc9004000000, length 134217728
[ 611.592794] Altera PCIE 0000:01:00.0: BAR[2] mapped to 0xfffffc9005000000, length 134217728
[ 611.592798] Altera PCIE 0000:01:00.0: BAR[4] mapped to 0xfffffc9006000000, length 134217728

```

Figure 7-3 Install PCIe Driver

■ Create a Software Application

All the files needed to create a PCIe software application are located in the directory: CDRROM/Demonstration/PCie_SW_KIT/Linux/PCie_Library , It includes the following files:

- TERASIC_PCIE_mSGDMA.h
- terasic_pcie_msgdma.so (64-bit Library)

1. Create a 64-bit C/C++ project.
2. Include TERASIC_PCIE_mSGDMA.h in the C/C++ project.
3. Copy terasic_pcie_msgdma.so to the folder where the project execution file is located.
4. Dynamically load terasic_pcie_msgdma.so in C/C++ program. To load the terasic_pcie_msgdma.so, please refer to the PCIe fundamental example below.
5. Call the library SDK API to implement the desired application.

Users can easily communicate with the FPGA through the PCIe bus through the terasic_pcie_msgdma.so API.

7.4 PCIe Library API

The API is the same as Windows Library. Please refer to the section **6.4 PCI Express Library API**.

7.5 PCIe Reference Design - Fundamental

The application reference design shows how to implement fundamental control and data transfer in the DMA. In the design, basic I/O is used to control the BUTTON and LED on the FPGA board. High-speed data transfer is performed by the DMA.

■ Demonstration Files Location

The demo file is located in the batch folder:

CDROM\demonstrations\TR4_x30\PCIe_Fundamental\demo_batch

The folder includes following files:

- FPGA Configuration File: PCIe_Fundamental.sof
- Download Batch file: test.bat
- Windows Application Software folder : windows_app, includes
 - PCIE_FUNDAMENTAL.exe
 - TERASIC_PCIE_mSGDMA.dll

■ Demonstration Setup

The demo file is located in the batch folder:

1. Use the PCIe cable to connect to the TR4 PCIE0 connector and PCIe adapter card 3 (PCA3) as shown in **Figure 7-4**.

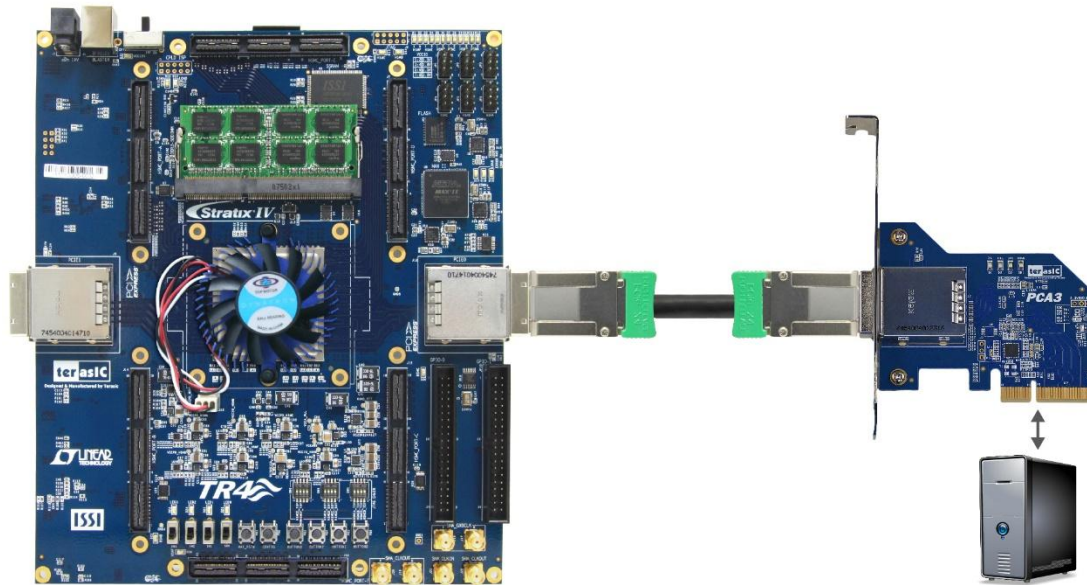

Figure 7-4 FPGA board connect to PC

2. Open a terminal and use "cd" command to goto

“CDROM/Demonstration/TR4_x30/PCIe_Fundamental/demo_batch”.

3. Set QUARTUS_ROOTDIR variable pointing to the Quartus installation path. Set QUARTUS_ROOTDIR variable by typing the following commands in terminal. Replace “/home/centos/intelFPGA/17.0/quartus/” Quartus installation path.

```
export QUARTUS_ROOTDIR=/home/centos/intelFPGA/20.1/quartus/
```

4. Execute "sudo -E sh test.sh" command to configure the FPGA.
5. Restart Linux.
6. Install PCIe driver. The driver is located in the folder: “CDROM/Demonstration/PCIe_SW_KIT/Linux/PCIe_Driver”
7. Type “ls -l /dev/altera_pcie*” to make sure the Linux has detected the FPGA Board. If the FPGA board is detected, developers can find the /dev/altera_pcieX (where X is 0~255) in Linux file system as shown in **Figure 7-5**.

```
centos@localhost:PCIe_Driver$ ls -l /dev/altera_pcie*
crw-rw-rw-. 1 root wheel 244, 0 Mar  5 13:58 /dev/altera_pcie0
centos@localhost:PCIe_Driver$ █
```

Figure 7-5 Detect FPGA PCIe

8. Goto linux_app folder, execute PCIE_FUNDAMENTAL using the following command. A menu will appear as shown in **Figure 7-6**.

```
chmod +x PCIE_FUNDAMENTAL    # Add executable permissions
./PCIE_FUNDAMENTAL           # Execute
```

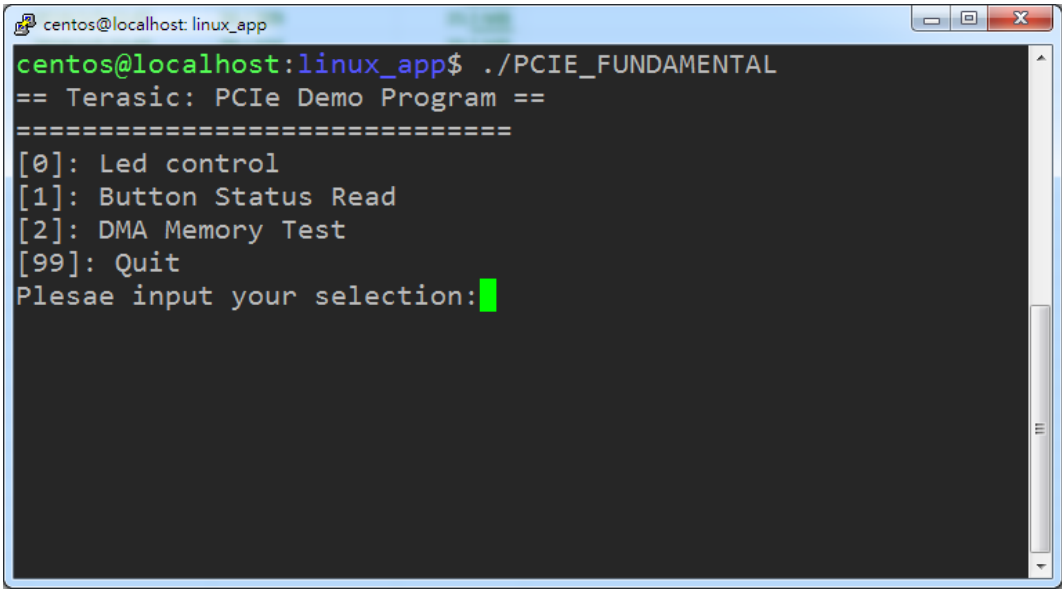

Figure 7-6 Screenshot of Program Menu

9. Type 0 followed by the ENTER key to select the Led Control item, then input 15 (hex 0x0f) will turn all leds on as shown in **Figure 7-7**. If input 0 (hex 0x00), all the LEDs will be turned off.

```
centos@localhost: linux_app
centos@localhost:linux_app$ ./PCIE_FUNDAMENTAL
== Terasic: PCIe Demo Program ==
=====
[0]: Led control
[1]: Button Status Read
[2]: DMA Memory Test
[99]: Quit
Plesae input your selection:0
Please input led conrol mask:15
Led control success, mask=fh
=====
[0]: Led control
[1]: Button Status Read
[2]: DMA Memory Test
[99]: Quit
Plesae input your selection:█
```

Figure 7-7 LED Control

10. Type 1 followed by the ENTER key to select the Button Status Read item. The button status will be reported as shown in **Figure 7-8**.

```
centos@localhost: linux_app
Plesae input your selection:0
Please input led conrol mask:15
Led control success, mask=fh
=====
[0]: Led control
[1]: Button Status Read
[2]: DMA Memory Test
[99]: Quit
Plesae input your selection:1
Button status mask:=fh
=====
[0]: Led control
[1]: Button Status Read
[2]: DMA Memory Test
[99]: Quit
Plesae input your selection:█
```

Figure 7-8 Button Status Report

11. Type 2 followed by the ENTER key to select the DMA Testing item. The DMA test result will be reported as shown in **Figure 7-9**.

```
centos@localhost: linux_app
[99]: Quit
Plesae input your selection:1
Button status mask:=fh
=====
[0]: Led control
[1]: Button Status Read
[2]: DMA Memory Test
[99]: Quit
Plesae input your selection:2
DMA-Memory (Size = 524288 bytes) pass
=====
[0]: Led control
[1]: Button Status Read
[2]: DMA Memory Test
[99]: Quit
Plesae input your selection:█
```

Figure 7-9 DMA Memory Test Result

12. Type 99 followed by the ENTER key to exit this test program.

■ Development Tools

- Quartus Prime 20.1.1 Standard Edition
- GNU Compiler Collection, Version 4.8 is recommended

■ Demonstration Source Code Location

- Quartus Project: Demonstrations\TR4_x30\PCie_Fundamental
- C++ Project:
Demonstration\tr4_x30\PCie_SW_KIT\Linux\PCIE_FUNDAMENTAL

■ FPGA Application Design

Figure 7-10 shows the system block diagram in the FPGA system. In the Qsys, PIO controller is used to control the LED and monitor the Button Status, and the On-Chip Memory is used for performing DMA testing. The PIO controllers and the On-Chip Memory are connected to the PCIe Hard IP controller through the Avalon-MM Interface.

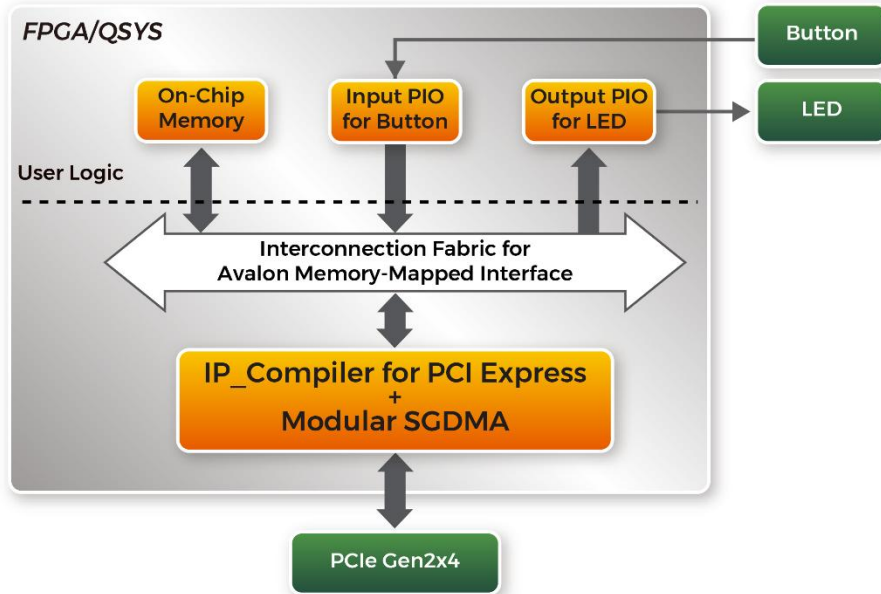

Figure 7-10 Hardware block diagram of the PCIe reference design

Linux Based Application Software Design

The application software project is built by the GNU Toolchain. The project includes the following major files:

Name	Description
PCIE_FUNDAMENTAL.cpp	Main program
PCIE.c	Implement dynamically load for terasic_pcie_msgdma.so library file
PCIE.h	
TERASIC_PCIE_mSGDMA.h	SDK library file, defines constant and data structure

The main program PCIE_FUNDAMENTAL.cpp includes the header file "PCIE.h" and defines the controller address according to the FPGA design.

```
#include "PCIE.h"

#define DEMO_PCIE_USER_BAR          PCIE_BAR4
#define DEMO_PCIE_IO_LED_ADDR      0x4000010
#define DEMO_PCIE_IO_BUTTON_ADDR   0x4000020
#define DEMO_PCIE_MEM_ADDR         0x07000000

#define MEM_SIZE                     (512*1024) //512KB
```

Before accessing the FPGA through PCIe, the application first calls `PCIE_Load` to dynamically load the `terasic_pcie_msgdma.so`. Then, it calls `PCIE_Open` to open the PCIe driver. The constant `DEFAULT_PCIE_VID` and `DEFAULT_PCIE_DID` used in `PCIE_Open` are defined in `TERASIC_PCIE_mSGDMA.h`. If developer change the Vendor ID and Device ID and PCIe IP, they also need to change the ID value define in `TERASIC_PCIE_mSGDMA.h`. If the return value of `PCIE_Open` is zero, it means the driver cannot be accessed successfully. In this case, please make sure:

- The FPGA is configured with the associated bit-stream file and the host is rebooted.
- The PCI express driver is loaded successfully.

The LED control is implemented by calling **PCIE_Write32 API**, as shown below:

```
bPass = PCIE_Write32(hPCIE, DEMO_PCIE_USER_BAR, DEMO_PCIE_IO_LED_ADDR, (uint32_t) Mask);
```

The button status query is implemented by calling the **PCIE_Read32 API**, as shown below:

```
PCIE_Read32(hPCIE, DEMO_PCIE_USER_BAR, DEMO_PCIE_IO_BUTTON_ADDR, &Status);
```

The memory-mapped memory read and write test is implemented by **PCIE_DmaWrite** and **PCIE_DmaRead** API, as shown below:

```
PCIE_DmaWrite(hPCIE, LocalAddr, pWrite, nTestSize);  
PCIE_DmaRead(hPCIE, LocalAddr, pRead, nTestSize);
```

7.6 PCIe Reference Design - DDR3

The application reference design shows how to add DDR3 Memory Controllers for DDR3 SODIMM into the PCIe Quartus project based on the `PCIE_Fundamental` Quartus project and perform 1GB data DMA for both SODIMM. Also, this demo shows how to call “**PCIE_ConfigRead32**” API to check PCIe link status.

■ Demonstration Files Location

The demo file is located in the batch folder:

“CDROM/Demonstration/TR4_x30/PCIE_DDR3/demo_batch”

The folder includes following files:

- FPGA Configuration File: PCIE_DDR3.sof
- Download Batch file: test.bat
- Linux Application Software folder: linux_app, includes
 - PCIE_DDR3
 - terasic_pcie_msgdma.so

■ Demonstration Setup

The demo file is located in the batch folder:

1. Install both DDR3 1066 1GB SODIMM on the FPGA board.
2. Install the FPGA board on your PC.
3. Open a terminal and use "cd" command to goto

“CDROM/Demonstration/TR4_x30/PCIE_DDR3/demo_batch”.

4. Set QUARTUS_ROOTDIR variable pointing to the Quartus installation path. Set QUARTUS_ROOTDIR variable by typing the following commands in the terminal. Replace /home/centos/intelFPGA/20.1/quartus/ to your Quartus installation path.

```
export QUARTUS_ROOTDIR=/home/centos/intelFPGA/20.1/quartus/
```

5. Execute "sudo -E sh test.sh" command to configure the FPGA.
6. Restart Linux.
7. Install PCIe driver
8. As shown in **Figure 7-11**, goto linux_app folder, execute PCIE_DDR3 using the following command :

```
chmod +x PCIE_DDR3      # Add executable permissions

./PCIE_DDR3            # Execute
```

```
centos@localhost: linux_app
centos@localhost:linux_app$ ./PCIE_DDR3
== Terasic: PCIe Demo Program ==
=====
[0]: Led control
[1]: Button Status Read
[2]: Link Info
[3]: DMA On-Chip Memory Test
[4]: DMA DDR3 Memory Test
[99]: Quit
Plesae input your selection:█
```

Figure 7-11 Program Menu

- 9. Type 2 followed by the ENTER key to select Link Info item. The PCIe link information will be shown as in Figure 7-12. Note that the test item 0 and item 1 (LED and button test) are belong PICE fundamental test, please refer to section 7.5.

```
=====
[0]: Led control
[1]: Button Status Read
[2]: Link Info
[3]: DMA On-Chip Memory Test
[4]: DMA DDR3 Sodimm Memory Test
[99]: Quit
Plesae input your selection:2
Vender ID:1172h
Device ID:E001h
Current Link Speed is Gen2
Negotiated Link Width is x4
Maximum Payload Size is 256-byte
=====
[0]: Led control
[1]: Button Status Read
[2]: Link Info
[3]: DMA On-Chip Memory Test
[4]: DMA DDR3 Sodimm Memory Test
[99]: Quit
Plesae input your selection:█
```

Figure 7-12 Link Information

- 10. Type 3 followed by the ENTER key to select the DMA On-Chip Memory Test item. The DMA write and read test result will be report as shown in Figure 7-13.

```
centos@localhost: linux_app
[99]: Quit
Plesae input your selection:3
DMA Memory Test, Address = 0x7000000, Size = 0x80000 Bytes...
Generate Test Pattern...
DMA Write...
DMA Read...
Readback Data Verify...
DMA-Memory Address = 0x7000000, Size = 0x80000 bytes pass
=====
[0]: Led control
[1]: Button Status Read
[2]: Link Info
[3]: DMA On-Chip Memory Test
[4]: DMA DDR3 Memory Test
[99]: Quit
Plesae input your selection:█
```

Figure 7-13 On-Chip Memory DMA Test Result

- 11. Type 4 followed by the ENTER key to select the DMA DDR Memory Test item. The DMA write and read test result will be report as shown in Figure 7-14.

```
centos@localhost: linux_app
Plesae input your selection:4
DMA Memory Test, Address = 0x40000000, Size = 0x40000000 Bytes...
Generate Test Pattern...
DMA Write...
DMA Read...
Readback Data Verify...
DMA-Memory Address = 0x40000000, Size = 0x40000000 bytes pass
=====
[0]: Led control
[1]: Button Status Read
[2]: Link Info
[3]: DMA On-Chip Memory Test
[4]: DMA DDR3 Memory Test
[99]: Quit
Plesae input your selection:█
```

Figure 7-14 DDR3 Memory DMA Test Result

- 12. Type 99 followed by the ENTER key to exit this test program.

■ Development Tools

- Quartus Prime 20.1.1 Standard Edition
- GNU Compiler Collection, Version 4.8 is recommended

■ Demonstration Source Code Location

- Quartus Project: Demonstrations\TR4_x30\PCIE_DDR3
- C++ Project: Demonstration/PCIE_SW_KIT/Linux/PCIE_DDR3

■ FPGA Application Design

Figure 7-15 shows the system block diagram in the FPGA system. In the Qsys, PIO controller is used to control the LED and monitor the Button Status, and the On-Chip memory and DDR3 are used for performing DMA testing. The PIO controllers and the On-Chip Memory and DDR3 are connected to the PCIe Hard IP controller through the Avalon-MM Interface.

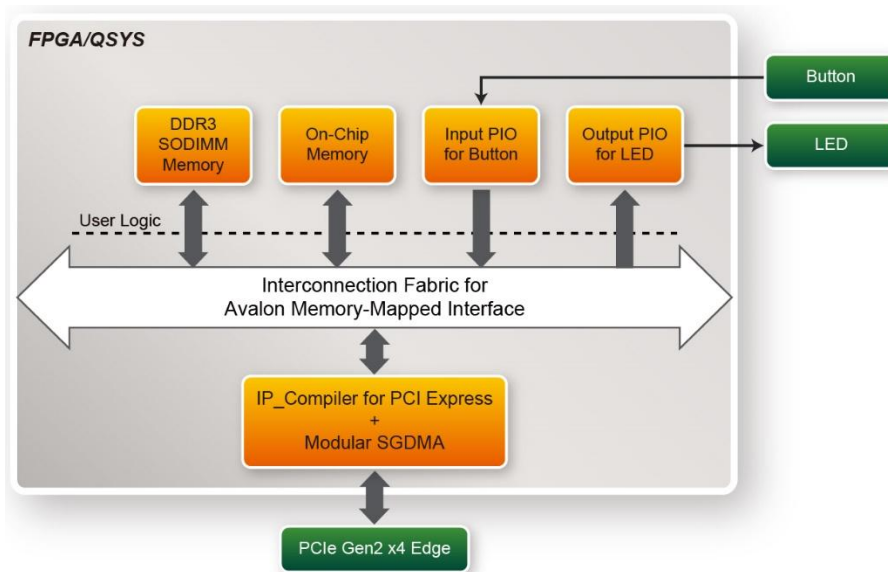

Figure 7-15 Hardware block diagram of the PCIe_DDR3 reference design

■ Linux Based Application Software Design

The application software project is built by Visual C++ 2012. The project includes the following major files:

Name	Description
------	-------------

PCIE_DDR3.cpp	Main program
PCIE.c	Implement dynamically load for terasic_pcie_msgdma.so library file
PCIE.h	
TERASIC_PCIE_mSGDMA.h	SDK library file, defines constant and data structure

The main program PCIE_DDR3.cpp includes the header file "PCIE.h" and defines the controller address according to the FPGA design.

```
#define DEMO_PCIE_USER_BAR          PCIE_BAR4
#define DEMO_PCIE_IO_LED_ADDR      0x4000010
#define DEMO_PCIE_IO_BUTTON_ADDR  0x4000020
#define DEMO_PCIE_ONCHIP_MEM_ADDR  0x07000000
#define DEMO_PCIE_DDR3_MEM_ADDR   0x40000000

#define ONCHIP_MEM_TEST_SIZE      (512*1024) //512KB
#define DDR3_MEM_TEST_SIZE       (1*1024*1024*1024) //1GB
#define DMA_CHUNK_SIZE          (1*1024*1024*1024) //1GB
```

The above definition is the same as those in PCIe Fundamental demo.

Before accessing the FPGA through the PCIe, the application first calls the PCIE_Load to dynamically load the terasic_pcie_msgdma.so. Then, it calls the PCIE_Open to open the PCIe driver. The constant DEFAULT_PCIE_VID and DEFAULT_PCIE_DID are defined in TERASIC_PCIE_mSGDMA.h. If developer change the Vendor ID and Device ID and PCIe IP, they also need to change the ID value define in TERASIC_PCIE_mSGDMA.h. If the return value of the PCIE_Open is zero, it means the driver cannot be accessed successfully. In this case, please make sure:

- The FPGA is configured with the associated bit-stream file and the host is rebooted.
- The PCI express driver is loaded successfully.

The LED control is implemented by calling **PCIE_Write32** API, as shown below:

```
bPass = PCIE_Write32(hPCIE, DEMO_PCIE_USER_BAR, DEMO_PCIE_IO_LED_ADDR, (uint32_t) Mask);
```

The button status query is implemented by calling the **PCIE_Read32** API, as shown below:

```
PCIE_Read32(hPCIE, DEMO_PCIE_USER_BAR, DEMO_PCIE_IO_BUTTON_ADDR, &Status);
```

The memory-mapped memory read and write test is implemented by **PCIE_DmaWrite** and **PCIE_DmaRead** API, as shown below:

```
PCIE_DmaWrite(hPCIE, LocalAddr, pWrite, nTestSize);
PCIE_DmaRead(hPCIE, LocalAddr, pRead, nTestSize);
```

The pcie link information is implemented by PCIE_ConfigRead32 API, as shown below:

```
// read config - link status
if (PCIE_ConfigRead32(hPCIE, 0x90, &Data32)){
    switch((Data32 >> 16) & 0x0F){
        case 1:
            printf("Current Link Speed is Gen1\r\n");
            break;
        case 2:
            printf("Current Link Speed is Gen2\r\n");
            break;
        case 3:
            printf("Current Link Speed is Gen3\r\n");
            break;
        default:
            printf("Current Link Speed is Unknown\r\n");
            break;
    }
    switch((Data32 >> 20) & 0x3F){
        case 1:
            printf("Negotiated Link Width is x1\r\n");
            break;
        case 2:
            printf("Negotiated Link Width is x2\r\n");
            break;
        case 4:
            printf("Negotiated Link Width is x4\r\n");
            break;
        case 8:
            printf("Negotiated Link Width is x8\r\n");
            break;
        case 16:
            printf("Negotiated Link Width is x16\r\n");
            break;
        default:
            printf("Negotiated Link Width is Unknown\r\n");
            break;
    }
}
else{
    bPass = false;
}
```

Chapter 8

Appendix A: HSMC Pin Assignment

Table 8-1 HSMC Port A Pin Assignments, Schematic Signal Names, and Functions

Board Reference (J6)	Schematic Signal Name	Description	I/O Standard	Stratix IV GX Pin Number
1	HSMA_GXB_TX_p7	Transceiver TX bit 7	1.4-V PCML	B4
2	HSMA_GXB_RX_p7	Transceiver RX bit 7	1.4-V PCML	C2
3	HSMA_GXB_TX_n7	Transceiver TX bit 7n	1.4-V PCML	B3
4	HSMA_GXB_RX_n7	Transceiver RX bit 7n	1.4-V PCML	C1
5	HSMA_GXB_TX_p6	Transceiver TX bit 6	1.4-V PCML	D4
6	HSMA_GXB_RX_p6	Transceiver TX bit 6	1.4-V PCML	E2
7	HSMA_GXB_TX_n6	Transceiver TX bit 6n	1.4-V PCML	D3
8	HSMA_GXB_RX_n6	Transceiver RX bit 6n	1.4-V PCML	E1
9	HSMA_GXB_TX_p5	Transceiver TX bit 5	1.4-V PCML	K4
10	HSMA_GXB_RX_p5	Transceiver RX bit 5	1.4-V PCML	L2
11	HSMA_GXB_TX_n5	Transceiver RX bit 5n	1.4-V PCML	K3
12	HSMA_GXB_RX_n5	Transceiver RX bit 5n	1.4-V PCML	L1
13	HSMA_GXB_TX_p4	Transceiver TX bit 4	1.4-V PCML	M4
14	HSMA_GXB_RX_p4	Transceiver RX bit 4	1.4-V PCML	N2
15	HSMA_GXB_TX_n4	Transceiver TX bit 4n	1.4-V PCML	M3
16	HSMA_GXB_RX_n4	Transceiver RX bit 4n	1.4-V PCML	N1
17	HSMA_GXB_TX_p3	Transceiver TX bit 3	1.4-V PCML	P4
18	HSMA_GXB_RX_p3	Transceiver TX bit 3	1.4-V PCML	R2
19	HSMA_GXB_TX_n3	Transceiver TX bit 3n	1.4-V PCML	P3
20	HSMA_GXB_RX_n3	Transceiver RX bit 3n	1.4-V PCML	R1
21	HSMA_GXB_TX_p2	Transceiver TX bit 2	1.4-V PCML	T4
22	HSMA_GXB_RX_p2	Transceiver RX bit 2	1.4-V PCML	U2
23	HSMA_GXB_TX_n2	Transceiver RX bit 2n	1.4-V PCML	T3
24	HSMA_GXB_RX_n2	Transceiver RX bit 2n	1.4-V PCML	U1
25	HSMA_GXB_TX_p1	Transceiver TX bit 1	1.4-V PCML	AB4
26	HSMA_GXB_RX_p1	Transceiver RX bit 1	1.4-V PCML	AC2
27	HSMA_GXB_TX_n1	Transceiver TX bit 1n	1.4-V PCML	AB3
28	HSMA_GXB_RX_n1	Transceiver RX bit 1n	1.4-V PCML	AC1
29	HSMA_GXB_TX_p0	Transceiver TX bit 0	1.4-V PCML	AD4

30	HSMA_GXB_RX_p0	Transceiver TX bit 0	1.4-V PCML	AE2
31	HSMA_GXB_TX_n0	Transceiver TX bit 0n	1.4-V PCML	AD3
32	HSMA_GXB_RX_n0	Transceiver RX bit 0n	1.4-V PCML	AE1
39	HSMA_OUT0	CMOS I/O	LVDS or 2.5-V	D10
40	HSMA_CLKIN0	CMOS I/O	LVDS or 2.5-V	C10
41	HSMA_D0	LVDS TX or CMOS I/O	LVDS or 2.5-V	AK8
42	HSMA_D1	LVDS RX or CMOS I/O	LVDS or 2.5-V	AP6
43	HSMA_D2	LVDS TX or CMOS I/O	LVDS or 2.5-V	AK7
44	HSMA_D3	LVDS RX or CMOS I/O	LVDS or 2.5-V	AP5
47	HSMA_TX_p0	LVDS TX bit 0 or CMOS I/O	LVDS or 2.5-V	AG10
48	HSMA_RX_p0	LVDS RX bit 0 or CMOS I/O	LVDS or 2.5-V	AN6
49	HSMA_TX_n0	LVDS TX bit 0n or CMOS I/O	LVDS or 2.5-V	AG9
50	HSMA_RX_n0	LVDS RX bit 0n or CMOS I/O	LVDS or 2.5-V	AN5
53	HSMA_TX_p1	LVDS TX bit 1 or CMOS I/O	LVDS or 2.5-V	AH9
54	HSMA_RX_p1	LVDS RX bit 1 or CMOS I/O	LVDS or 2.5-V	AM6
55	HSMA_TX_n1	LVDS TX bit 1n or CMOS I/O	LVDS or 2.5-V	AH8
56	HSMA_RX_n1	LVDS RX bit 1n or CMOS I/O	LVDS or 2.5-V	AM5
59	HSMA_TX_p2	LVDS TX bit 2 or CMOS I/O	LVDS or 2.5-V	AG8
60	HSMA_RX_p2	LVDS RX bit 2 or CMOS I/O	LVDS or 2.5-V	AL6
61	HSMA_TX_n2	LVDS TX bit 2n or CMOS I/O	LVDS or 2.5-V	AG7
62	HSMA_RX_n2	LVDS RX bit 2n or CMOS I/O	LVDS or 2.5-V	AL5
65	HSMA_TX_p3	LVDS TX bit 3 or CMOS I/O	LVDS or 2.5-V	AF11
66	HSMA_RX_p3	LVDS RX bit 3 or CMOS I/O	LVDS or 2.5-V	AK6
67	HSMA_TX_n3	LVDS TX bit 3n or CMOS I/O	LVDS or 2.5-V	AF10
68	HSMA_RX_n3	LVDS RX bit 3n or CMOS I/O	LVDS or 2.5-V	AK5
71	HSMA_TX_p4	LVDS TX bit 4 or CMOS I/O	LVDS or 2.5-V	AD10
72	HSMA_RX_p4	LVDS RX bit 4 or CMOS I/O	LVDS or 2.5-V	AJ6
73	HSMA_TX_n4	LVDS TX bit 4n or CMOS I/O	LVDS or 2.5-V	AD9
74	HSMA_RX_n4	LVDS RX bit 4n or CMOS I/O	LVDS or 2.5-V	AJ5
77	HSMA_TX_p5	LVDS TX bit 5 or CMOS I/O	LVDS or 2.5-V	AB13
78	HSMA_RX_p5	LVDS RX bit 5 or CMOS I/O	LVDS or 2.5-V	AH6
79	HSMA_TX_n5	LVDS TX bit 5n or CMOS I/O	LVDS or 2.5-V	AB12
80	HSMA_RX_n5	LVDS RX bit 5n or CMOS I/O	LVDS or 2.5-V	AH5
83	HSMA_TX_p6	LVDS TX bit 6 or CMOS I/O	LVDS or 2.5-V	AB11
84	HSMA_RX_p6	LVDS RX bit 6 or CMOS I/O	LVDS or 2.5-V	AG6
85	HSMA_TX_n6	LVDS TX bit 6n or CMOS I/O	LVDS or 2.5-V	AB10
86	HSMA_RX_n6	LVDS RX bit 6n or CMOS I/O	LVDS or 2.5-V	AG5
89	HSMA_TX_p7	LVDS TX bit 7 or CMOS I/O	LVDS or 2.5-V	T13
90	HSMA_RX_p7	LVDS RX bit 7 or CMOS I/O	LVDS or 2.5-V	AB9
91	HSMA_TX_n7	LVDS TX bit 7n or CMOS I/O	LVDS or 2.5-V	T12
92	HSMA_RX_n7	LVDS RX bit 7n or CMOS I/O	LVDS or 2.5-V	AC8
95	HSMA_CLKOUT_p1	LVDS TX or CMOS I/O	LVDS or 2.5-V	R12
96	HSMA_CLKIN_p1	LVDS RX or CMOS input or	LVDS or 2.5-V	AF6

		differential clock input		
97	HSMA_CLKOUT_n1	LVDS RX or CMOS I/O	LVDS or 2.5-V	R11
98	HSMA_CLKIN_n1	LVDS RX or CMOS input or differential clock input	LVDS or 2.5-V	AE5
101	HSMA_TX_p8	LVDS TX bit 8 or CMOS I/O	LVDS or 2.5-V	R13
102	HSMA_RX_p8	LVDS RX bit 8 or CMOS I/O	LVDS or 2.5-V	F10
103	HSMA_TX_n8	LVDS TX bit 8n or CMOS I/O	LVDS or 2.5-V	P13
104	HSMA_RX_n8	LVDS RX bit 8n or CMOS I/O	LVDS or 2.5-V	E10
107	HSMA_TX_p9	LVDS TX bit 9 or CMOS I/O	LVDS or 2.5-V	N11
108	HSMA_RX_p9	LVDS RX bit 9 or CMOS I/O	LVDS or 2.5-V	G9
109	HSMA_TX_n9	LVDS TX bit 9n or CMOS I/O	LVDS or 2.5-V	N10
110	HSMA_RX_n9	LVDS RX bit 9n or CMOS I/O	LVDS or 2.5-V	F9
113	HSMA_TX_p10	LVDS TX bit 10 or CMOS I/O	LVDS or 2.5-V	N12
114	HSMA_RX_p10	LVDS RX bit 10 or CMOS I/O	LVDS or 2.5-V	D9
115	HSMA_TX_n10	LVDS TX bit 10n or CMOS I/O	LVDS or 2.5-V	M12
116	HSMA_RX_n10	LVDS RX bit 10n or CMOS I/O	LVDS or 2.5-V	C9
119	HSMA_TX_p11	LVDS TX bit 11 or CMOS I/O	LVDS or 2.5-V	M10
120	HSMA_RX_p11	LVDS RX bit 11 or CMOS I/O	LVDS or 2.5-V	G6
121	HSMA_TX_n11	LVDS TX bit 11n or CMOS I/O	LVDS or 2.5-V	L10
122	HSMA_RX_n11	LVDS RX bit 11n or CMOS I/O	LVDS or 2.5-V	F6
125	HSMA_TX_p12	LVDS TX bit 12 or CMOS I/O	LVDS or 2.5-V	M11
126	HSMA_RX_p12	LVDS RX bit 12 or CMOS I/O	LVDS or 2.5-V	G5
127	HSMA_TX_n12	LVDS TX bit 12n or CMOS I/O	LVDS or 2.5-V	L11
128	HSMA_RX_n12	LVDS RX bit 12n or CMOS I/O	LVDS or 2.5-V	F5
131	HSMA_TX_p13	LVDS TX bit 13 or CMOS I/O	LVDS or 2.5-V	K8
132	HSMA_RX_p13	LVDS RX bit 13 or CMOS I/O	LVDS or 2.5-V	F7
133	HSMA_TX_n13	LVDS TX bit 13n or CMOS I/O	LVDS or 2.5-V	J8
134	HSMA_RX_n13	LVDS RX bit 13n or CMOS I/O	LVDS or 2.5-V	E7
137	HSMA_TX_p14	LVDS TX bit 14 or CMOS I/O	LVDS or 2.5-V	K9
138	HSMA_RX_p14	LVDS RX bit 14 or CMOS I/O	LVDS or 2.5-V	D8
139	HSMA_TX_n14	LVDS TX bit 14n or CMOS I/O	LVDS or 2.5-V	J9
140	HSMA_RX_n14	LVDS RX bit 14n or CMOS I/O	LVDS or 2.5-V	C8
143	HSMA_TX_p15	LVDS TX bit 15 or CMOS I/O	LVDS or 2.5-V	H7
144	HSMA_RX_p15	LVDS RX bit 15 or CMOS I/O	LVDS or 2.5-V	D5
145	HSMA_TX_n15	LVDS TX bit 15n or CMOS I/O	LVDS or 2.5-V	G7
146	HSMA_RX_n15	LVDS RX bit 15n or CMOS I/O	LVDS or 2.5-V	C5
149	HSMA_TX_p16	LVDS TX bit 16 or CMOS I/O	LVDS or 2.5-V	K10
150	HSMA_RX_p16	LVDS RX bit 16 or CMOS I/O	LVDS or 2.5-V	D7
151	HSMA_TX_n16	LVDS TX bit 16n or CMOS I/O	LVDS or 2.5-V	J10
152	HSMA_RX_n16	LVDS RX bit 16n or CMOS I/O	LVDS or 2.5-V	C7
155	HSMA_OUT_p2	LVDS TX or CMOS I/O	LVDS or 2.5-V	H10
156	HSMA_CLKIN_p2	LVDS RX or CMOS input or differential clock input	LVDS or 2.5-V	AC6

157	HSMA_OUT_n2	LVDS TX or CMOS I/O	LVDS or 2.5-V	G10
158	HSMA_CLKIN_n2	LVDS RX or CMOS input or differential clock input/	LVDS or 2.5-V	AC5

Table 8-2 HSMC Port B Pin Assignments, Schematic Signal Names, and Functions

<i>Board Reference (J14)</i>	<i>Schematic Signal Name</i>	<i>Description</i>	<i>I/O Standard</i>	<i>Stratix IV GX Pin Number</i>
39	HSMB_OUT0	CMOS I/O	LVDS or 2.5-V	AN15
40	HSMB_CLKIN0	CMOS I/O	LVDS or 2.5-V	AP15
41	HSMB_D0	LVDS TX or CMOS I/O	LVDS or 2.5-V	AD15
42	HSMB_D1	LVDS RX or CMOS I/O	LVDS or 2.5-V	AV13
43	HSMB_D2	LVDS TX or CMOS I/O	LVDS or 2.5-V	AE15
44	HSMB_D3	LVDS RX or CMOS I/O	LVDS or 2.5-V	AW13
47	HSMB_TX_p0	LVDS TX bit 0 or CMOS I/O	LVDS or 2.5-V	AN13
48	HSMB_RX_p0	LVDS RX bit 0 or CMOS I/O	LVDS or 2.5-V	AV10
49	HSMB_TX_n0	LVDS TX bit 0n or CMOS I/O	LVDS or 2.5-V	AL15
50	HSMB_RX_n0	LVDS RX bit 0n or CMOS I/O	LVDS or 2.5-V	AW10
53	HSMB_TX_p1	LVDS TX bit 1 or CMOS I/O	LVDS or 2.5-V	AT14
54	HSMB_RX_p1	LVDS RX bit 1 or CMOS I/O	LVDS or 2.5-V	AT9
55	HSMB_TX_n1	LVDS TX bit 1n or CMOS I/O	LVDS or 2.5-V	AU14
56	HSMB_RX_n1	LVDS RX bit 1n or CMOS I/O	LVDS or 2.5-V	AU9
59	HSMB_TX_p2	LVDS TX bit 2 or CMOS I/O	LVDS or 2.5-V	AW12
60	HSMB_RX_p2	LVDS RX bit 2 or CMOS I/O	LVDS or 2.5-V	AV7
61	HSMB_TX_n2	LVDS TX bit 2n or CMOS I/O	LVDS or 2.5-V	AW11
62	HSMB_RX_n2	LVDS RX bit 2n or CMOS I/O	LVDS or 2.5-V	AW7
65	HSMB_TX_p3	LVDS TX bit 3 or CMOS I/O	LVDS or 2.5-V	AL14
66	HSMB_RX_p3	LVDS RX bit 3 or CMOS I/O	LVDS or 2.5-V	AW6
67	HSMB_TX_n3	LVDS TX bit 3n or CMOS I/O	LVDS or 2.5-V	AM14
68	HSMB_RX_n3	LVDS RX bit 3n or CMOS I/O	LVDS or 2.5-V	AW5
71	HSMB_TX_p4	LVDS TX bit 4 or CMOS I/O	LVDS or 2.5-V	AT12
72	HSMB_RX_p4	LVDS RX bit 4 or CMOS I/O	LVDS or 2.5-V	AV5
73	HSMB_TX_n4	LVDS TX bit 4n or CMOS I/O	LVDS or 2.5-V	AU12
74	HSMB_RX_n4	LVDS RX bit 4n or CMOS I/O	LVDS or 2.5-V	AW4
77	HSMB_TX_p5	LVDS TX bit 5 or CMOS I/O	LVDS or 2.5-V	AP13
78	HSMB_RX_p5	LVDS RX bit 5 or CMOS I/O	LVDS or 2.5-V	AV8
79	HSMB_TX_n5	LVDS TX bit 5n or CMOS I/O	LVDS or 2.5-V	AN14
80	HSMB_RX_n5	LVDS RX bit 5n or CMOS I/O	LVDS or 2.5-V	AW8
83	HSMB_TX_p6	LVDS TX bit 6 or CMOS I/O	LVDS or 2.5-V	AG14
84	HSMB_RX_p6	LVDS RX bit 6 or CMOS I/O	LVDS or 2.5-V	AR5
85	HSMB_TX_n6	LVDS TX bit 6n or CMOS I/O	LVDS or 2.5-V	AG15
86	HSMB_RX_n6	LVDS RX bit 6n or CMOS I/O	LVDS or 2.5-V	AT5
89	HSMB_TX_p7	LVDS TX bit 7 or CMOS I/O	LVDS or 2.5-V	AN9
90	HSMB_RX_p7	LVDS RX bit 7 or CMOS I/O	LVDS or 2.5-V	AT6

91	HSMB_TX_n7	LVDS TX bit 7n or CMOS I/O	LVDS or 2.5-V	AP9
92	HSMB_RX_n7	LVDS RX bit 7n or CMOS I/O	LVDS or 2.5-V	AU6
95	HSMB_CLKOUT_p1	LVDS TX or CMOS I/O	LVDS or 2.5-V	AN10
96	HSMB_CLKIN_p1	LVDS RX or CMOS I/O	LVDS or 2.5-V	AT7
97	HSMB_CLKOUT_n1	LVDS TX or CMOS I/O	LVDS or 2.5-V	AP10
98	HSMB_CLKIN_n1	LVDS RX or CMOS I/O	LVDS or 2.5-V	AU7
101	HSMB_TX_p8	LVDS TX bit 8 or CMOS I/O	LVDS or 2.5-V	AL8
102	HSMB_RX_p8	LVDS RX bit 8 or CMOS I/O	LVDS or 2.5-V	AP8
103	HSMB_TX_n8	LVDS TX bit 8n or CMOS I/O	LVDS or 2.5-V	AM8
104	HSMB_RX_n8	LVDS RX bit 8n or CMOS I/O	LVDS or 2.5-V	AR8
107	HSMB_TX_p9	LVDS TX bit 9 or CMOS I/O	LVDS or 2.5-V	AK9
108	HSMB_RX_p9	LVDS RX bit 9 or CMOS I/O	LVDS or 2.5-V	AT8
109	HSMB_TX_n9	LVDS TX bit 9n or CMOS I/O	LVDS or 2.5-V	AL9
110	HSMB_RX_n9	LVDS RX bit 9n or CMOS I/O	LVDS or 2.5-V	AU8
113	HSMB_TX_p10	LVDS TX bit 10 or CMOS I/O	LVDS or 2.5-V	AL10
114	HSMB_RX_p10	LVDS RX bit 10 or CMOS I/O	LVDS or 2.5-V	AT10
115	HSMB_TX_n10	LVDS TX bit 10n or CMOS I/O	LVDS or 2.5-V	AM10
116	HSMB_RX_n10	LVDS RX bit 10n or CMOS I/O	LVDS or 2.5-V	AU10
119	HSMB_TX_p11	LVDS TX bit 11 or CMOS I/O	LVDS or 2.5-V	AH11
120	HSMB_RX_p11	LVDS RX bit 11 or CMOS I/O	LVDS or 2.5-V	AU11
121	HSMB_TX_n11	LVDS TX bit 11n or CMOS I/O	LVDS or 2.5-V	AJ11
122	HSMB_RX_n11	LVDS RX bit 11n or CMOS I/O	LVDS or 2.5-V	AV11
125	HSMB_TX_p12	LVDS TX bit 12 or CMOS I/O	LVDS or 2.5-V	AG12
126	HSMB_RX_p12	LVDS RX bit 12 or CMOS I/O	LVDS or 2.5-V	AR13
127	HSMB_TX_n12	LVDS TX bit 12n or CMOS I/O	LVDS or 2.5-V	AH12
128	HSMB_RX_n12	LVDS RX bit 12n or CMOS I/O	LVDS or 2.5-V	AT13
131	HSMB_TX_p13	LVDS TX bit 13 or CMOS I/O	LVDS or 2.5-V	AE13
132	HSMB_RX_p13	LVDS RX bit 13 or CMOS I/O	LVDS or 2.5-V	AJ13
133	HSMB_TX_n13	LVDS TX bit 13n or CMOS I/O	LVDS or 2.5-V	AE12
134	HSMB_RX_n13	LVDS RX bit 13n or CMOS I/O	LVDS or 2.5-V	AK13
137	HSMB_TX_p14	LVDS TX bit 14 or CMOS I/O	LVDS or 2.5-V	AF13
138	HSMB_RX_p14	LVDS RX bit 14 or CMOS I/O	LVDS or 2.5-V	AH14
139	HSMB_TX_n14	LVDS TX bit 14n or CMOS I/O	LVDS or 2.5-V	AG13
140	HSMB_RX_n14	LVDS RX bit 14n or CMOS I/O	LVDS or 2.5-V	AJ14
143	HSMB_TX_p15	LVDS TX bit 15 or CMOS I/O	LVDS or 2.5-V	AD13
144	HSMB_RX_p15	LVDS RX bit 15 or CMOS I/O	LVDS or 2.5-V	AE14
145	HSMB_TX_n15	LVDS TX bit 15n or CMOS I/O	LVDS or 2.5-V	AD12
146	HSMB_RX_n15	LVDS RX bit 15n or CMOS I/O	LVDS or 2.5-V	AF14
149	HSMB_TX_p16	LVDS TX bit 16 or CMOS I/O	LVDS or 2.5-V	AN7
150	HSMB_RX_p16	LVDS RX bit 16 or CMOS I/O	LVDS or 2.5-V	AL13
151	HSMB_TX_n16	LVDS TX bit 16n or CMOS I/O	LVDS or 2.5-V	AP7
152	HSMB_RX_n16	LVDS RX bit 16n or CMOS I/O	LVDS or 2.5-V	AM13
155	HSMB_OUT_p2	LVDS TX or CMOS I/O	LVDS or 2.5-V	AH10

156	HSMB_CLKIN_p2	LVDS RX or CMOS I/O	LVDS or 2.5-V	AV14
157	HSMB_OUT_n2	LVDS TX or CMOS I/O	LVDS or 2.5-V	AJ10
158	HSMB_CLKIN_n2	LVDS RX or CMOS I/O	LVDS or 2.5-V	AW14

Table 8-3 HSMC Port C Pin Assignments, Schematic Signal Names, and Functions

<i>Board Reference (J15)</i>	<i>Schematic Signal Name</i>	<i>Description</i>	<i>I/O Standard</i>	<i>Stratix IV GX Pin Number</i>
39	HSMC_OUT0	CMOS I/O	LVDS or 2.5-V	AT27
40	HSMC_CLKIN0	CMOS I/O	LVDS or 2.5-V	AU27
41	HSMC_D0	LVDS TX or CMOS I/O	LVDS or 2.5-V	AB27
42	HSMC_D1	LVDS RX or CMOS I/O	LVDS or 2.5-V	AJ25
43	HSMC_D2	LVDS TX or CMOS I/O	LVDS or 2.5-V	AB28
44	HSMC_D3	LVDS RX or CMOS I/O	LVDS or 2.5-V	AK25
47	HSMC_TX_p0	LVDS TX bit 0 or CMOS I/O	LVDS or 2.5-V	AC28
48	HSMC_RX_p0	LVDS RX bit 0 or CMOS I/O	LVDS or 2.5-V	AM26
49	HSMC_TX_n0	LVDS TX bit 0n or CMOS I/O	LVDS or 2.5-V	AC29
50	HSMC_RX_n0	LVDS RX bit 0n or CMOS I/O	LVDS or 2.5-V	AN26
53	HSMC_TX_p1	LVDS TX bit 1 or CMOS I/O	LVDS or 2.5-V	AD28
54	HSMC_RX_p1	LVDS RX bit 1 or CMOS I/O	LVDS or 2.5-V	AP28
55	HSMC_TX_n1	LVDS TX bit 1n or CMOS I/O	LVDS or 2.5-V	AD29
56	HSMC_RX_n1	LVDS RX bit 1n or CMOS I/O	LVDS or 2.5-V	AR28
59	HSMC_TX_p2	LVDS TX bit 2 or CMOS I/O	LVDS or 2.5-V	AE28
60	HSMC_RX_p2	LVDS RX bit 2 or CMOS I/O	LVDS or 2.5-V	AT28
61	HSMC_TX_n2	LVDS TX bit 2n or CMOS I/O	LVDS or 2.5-V	AE29
62	HSMC_RX_n2	LVDS RX bit 2n or CMOS I/O	LVDS or 2.5-V	AU28
65	HSMC_TX_p3	LVDS TX bit 3 or CMOS I/O	LVDS or 2.5-V	AF29
66	HSMC_RX_p3	LVDS RX bit 3 or CMOS I/O	LVDS or 2.5-V	AV28
67	HSMC_TX_n3	LVDS TX bit 3n or CMOS I/O	LVDS or 2.5-V	AG30
68	HSMC_RX_n3	LVDS RX bit 3n or CMOS I/O	LVDS or 2.5-V	AW29
71	HSMC_TX_p4	LVDS TX bit 4 or CMOS I/O	LVDS or 2.5-V	AE30
72	HSMC_RX_p4	LVDS RX bit 4 or CMOS I/O	LVDS or 2.5-V	AV29
73	HSMC_TX_n4	LVDS TX bit 4n or CMOS I/O	LVDS or 2.5-V	AE31
74	HSMC_RX_n4	LVDS RX bit 4n or CMOS I/O	LVDS or 2.5-V	AW30
77	HSMC_TX_p5	LVDS TX bit 5 or CMOS I/O	LVDS or 2.5-V	AG31
78	HSMC_RX_p5	LVDS RX bit 5 or CMOS I/O	LVDS or 2.5-V	AV32
79	HSMC_TX_n5	LVDS TX bit 5n or CMOS I/O	LVDS or 2.5-V	AG32
80	HSMC_RX_n5	LVDS RX bit 5n or CMOS I/O	LVDS or 2.5-V	AW32
83	HSMC_TX_p6	LVDS TX bit 6 or CMOS I/O	LVDS or 2.5-V	AD30
84	HSMC_RX_p6	LVDS RX bit 6 or CMOS I/O	LVDS or 2.5-V	AJ26
85	HSMC_TX_n6	LVDS TX bit 6n or CMOS I/O	LVDS or 2.5-V	AD31
86	HSMC_RX_n6	LVDS RX bit 6n or CMOS I/O	LVDS or 2.5-V	AK26
89	HSMC_TX_p7	LVDS TX bit 7 or CMOS I/O	LVDS or 2.5-V	AB30
90	HSMC_RX_p7	LVDS RX bit 7 or CMOS I/O	LVDS or 2.5-V	AF25
91	HSMC_TX_n7	LVDS TX bit 7n or CMOS I/O	LVDS or 2.5-V	AB31

92	HSMC_RX_n7	LVDS RX bit 7n or CMOS I/O	LVDS or 2.5-V	AG25
95	HSMC_CLKOUT_p1	LVDS TX or CMOS I/O or differential clock output	LVDS or 2.5-V	AG34
96	HSMC_CLKIN_p1	LVDS RX or CMOS input or differential clock input	LVDS or 2.5-V	AF34
97	HSMC_CLKOUT_n1	LVDS TX or CMOS I/O or differential clock output	LVDS or 2.5-V	AG35
98	HSMC_CLKIN_n1	LVDS RX or CMOS input or differential clock input	LVDS or 2.5-V	AE35
101	HSMC_TX_p8	LVDS TX bit 8 or CMOS I/O	LVDS or 2.5-V	AL27
102	HSMC_RX_p8	LVDS RX bit 8 or CMOS I/O	LVDS or 2.5-V	AJ32
103	HSMC_TX_n8	LVDS TX bit 8n or CMOS I/O	LVDS or 2.5-V	AH26
104	HSMC_RX_n8	LVDS RX bit 8n or CMOS I/O	LVDS or 2.5-V	AK33
107	HSMC_TX_p9	LVDS TX bit 9 or CMOS I/O	LVDS or 2.5-V	AK27
108	HSMC_RX_p9	LVDS RX bit 9 or CMOS I/O	LVDS or 2.5-V	AN34
109	HSMC_TX_n9	LVDS TX bit 9n or CMOS I/O	LVDS or 2.5-V	AE24
110	HSMC_RX_n9	LVDS RX bit 9n or CMOS I/O	LVDS or 2.5-V	AN35
113	HSMC_TX_p10	LVDS TX bit 10 or CMOS I/O	LVDS or 2.5-V	AW27
114	HSMC_RX_p10	LVDS RX bit 10 or CMOS I/O	LVDS or 2.5-V	AM34
115	HSMC_TX_n10	LVDS TX bit 10n or CMOS I/O	LVDS or 2.5-V	AW28
116	HSMC_RX_n10	LVDS RX bit 10n or CMOS I/O	LVDS or 2.5-V	AM35
119	HSMC_TX_p11	LVDS TX bit 11 or CMOS I/O	LVDS or 2.5-V	AH24
120	HSMC_RX_p11	LVDS RX bit 11 or CMOS I/O	LVDS or 2.5-V	AL34
121	HSMC_TX_n11	LVDS TX bit 11n or CMOS I/O	LVDS or 2.5-V	AG24
122	HSMC_RX_n11	LVDS RX bit 11n or CMOS I/O	LVDS or 2.5-V	AL35
125	HSMC_TX_p12	LVDS TX bit 12 or CMOS I/O	LVDS or 2.5-V	AW31
126	HSMC_RX_p12	LVDS RX bit 12 or CMOS I/O	LVDS or 2.5-V	AK34
127	HSMC_TX_n12	LVDS TX bit 12n or CMOS I/O	LVDS or 2.5-V	AV31
128	HSMC_RX_n12	LVDS RX bit 12n or CMOS I/O	LVDS or 2.5-V	AK35
131	HSMC_TX_p13	LVDS TX bit 13 or CMOS I/O	LVDS or 2.5-V	AW33
132	HSMC_RX_p13	LVDS RX bit 13 or CMOS I/O	LVDS or 2.5-V	AJ34
133	HSMC_TX_n13	LVDS TX bit 13n or CMOS I/O	LVDS or 2.5-V	AW34
134	HSMC_RX_n13	LVDS RX bit 13n or CMOS I/O	LVDS or 2.5-V	AJ35
137	HSMC_TX_p14	LVDS TX bit 14 or CMOS I/O	LVDS or 2.5-V	AL25
138	HSMC_RX_p14	LVDS RX bit 14 or CMOS I/O	LVDS or 2.5-V	AH34
139	HSMC_TX_n14	LVDS TX bit 14n or CMOS I/O	LVDS or 2.5-V	AP26
140	HSMC_RX_n14	LVDS RX bit 14n or CMOS I/O	LVDS or 2.5-V	AH35
143	HSMC_TX_p15	LVDS TX bit 15 or CMOS I/O	LVDS or 2.5-V	AU29
144	HSMC_RX_p15	LVDS RX bit 15 or CMOS I/O	LVDS or 2.5-V	AH32
145	HSMC_TX_n15	LVDS TX bit 15n or CMOS I/O	LVDS or 2.5-V	AT29
146	HSMC_RX_n15	LVDS RX bit 15n or CMOS I/O	LVDS or 2.5-V	AH33
149	HSMC_TX_p16	LVDS TX bit 16 or CMOS I/O	LVDS or 2.5-V	AP27
150	HSMC_RX_p16	LVDS RX bit 16 or CMOS I/O	LVDS or 2.5-V	AC31

151	HSMC_TX_n16	LVDS TX bit 16n or CMOS I/O	LVDS or 2.5-V	AN27
152	HSMC_RX_n16	LVDS RX bit 16n or CMOS I/O	LVDS or 2.5-V	AC32
155	HSMC_OUT_p2	LVDS TX or CMOS I/O	LVDS or 2.5-V	AE25
156	HSMC_CLKIN_p2	LVDS RX or CMOS input or differential clock input	LVDS or 2.5-V	AC34
157	HSMC_OUT_n2	LVDS TX or CMOS I/O	LVDS or 2.5-V	AD25
158	HSMC_CLKIN_n2	LVDS RX or CMOS input or differential clock input	LVDS or 2.5-V	AC35

Table 8-4 HSMC Port D Pin Assignments, Schematic Signal Names, and Functions

<i>Board Reference (J7)</i>	<i>Schematic Signal Name</i>	<i>Description</i>	<i>I/O Standard</i>	<i>Stratix IV GX Pin Number</i>
39	HSMD_OUT0	CMOS I/O	LVDS or 2.5-V	P19
40	HSMD_CLKIN0	Dedicated clock input	LVDS or 2.5-V	AA35
41	HSMD_D0	LVDS TX or CMOS I/O	LVDS or 2.5-V	AJ29
42	HSMD_D1	LVDS RX or CMOS I/O	LVDS or 2.5-V	AR31
43	HSMD_D2	LVDS TX or CMOS I/O	LVDS or 2.5-V	AK29
44	HSMD_D3	LVDS RX or CMOS I/O	LVDS or 2.5-V	AT30
47	HSMD_TX_p0	LVDS TX bit 0 or CMOS I/O	LVDS or 2.5-V	AL29
48	HSMD_RX_p0	LVDS RX bit 0 or CMOS I/O	LVDS or 2.5-V	AT31
49	HSMD_TX_n0	LVDS TX bit 0n or CMOS I/O	LVDS or 2.5-V	AM29
50	HSMD_RX_n0	LVDS RX bit 0n or CMOS I/O	LVDS or 2.5-V	AU31
53	HSMD_TX_p1	LVDS TX bit 1 or CMOS I/O	LVDS or 2.5-V	AK30
54	HSMD_RX_p1	LVDS RX bit 1 or CMOS I/O	LVDS or 2.5-V	AT32
55	HSMD_TX_n1	LVDS TX bit 1n or CMOS I/O	LVDS or 2.5-V	AL30
56	HSMD_RX_n1	LVDS RX bit 1n or CMOS I/O	LVDS or 2.5-V	AU32
59	HSMD_TX_p2	LVDS TX bit 2 or CMOS I/O	LVDS or 2.5-V	AK32
60	HSMD_RX_p2	LVDS RX bit 2 or CMOS I/O	LVDS or 2.5-V	AT33
61	HSMD_TX_n2	LVDS TX bit 2n or CMOS I/O	LVDS or 2.5-V	AL32
62	HSMD_RX_n2	LVDS RX bit 2n or CMOS I/O	LVDS or 2.5-V	AU33
65	HSMD_TX_p3	LVDS TX bit 3 or CMOS I/O	LVDS or 2.5-V	AJ31
66	HSMD_RX_p3	LVDS RX bit 3 or CMOS I/O	LVDS or 2.5-V	AU34
67	HSMD_TX_n3	LVDS TX bit 3n or CMOS I/O	LVDS or 2.5-V	AH30
68	HSMD_RX_n3	LVDS RX bit 3n or CMOS I/O	LVDS or 2.5-V	AV34
71	HSMD_TX_p4	LVDS TX bit 4 or CMOS I/O	LVDS or 2.5-V	AG27
72	HSMD_RX_p4	LVDS RX bit 4 or CMOS I/O	LVDS or 2.5-V	AN33
73	HSMD_TX_n4	LVDS TX bit 4n or CMOS I/O	LVDS or 2.5-V	AH27
74	HSMD_RX_n4	LVDS RX bit 4n or CMOS I/O	LVDS or 2.5-V	AP34
77	HSMD_TX_p5	LVDS TX bit 5 or CMOS I/O	LVDS or 2.5-V	AG29
78	HSMD_RX_p5	LVDS RX bit 5 or CMOS I/O	LVDS or 2.5-V	AT34

79	HSMD_TX_n5	LVDS TX bit 5n or CMOS I/O	LVDS or 2.5-V	AH29
80	HSMD_RX_n5	LVDS RX bit 5n or CMOS I/O	LVDS or 2.5-V	AR34
83	HSMD_TX_p6	LVDS TX bit 6 or CMOS I/O	LVDS or 2.5-V	AG28
84	HSMD_RX_p6	LVDS RX bit 6 or CMOS I/O	LVDS or 2.5-V	AP35
85	HSMD_TX_n6	LVDS TX bit 6n or CMOS I/O	LVDS or 2.5-V	AH28
86	HSMD_RX_n6	LVDS RX bit 6n or CMOS I/O	LVDS or 2.5-V	AR35
89	HSMD_TX_p7	LVDS TX bit 7 or CMOS I/O	LVDS or 2.5-V	AD27
90	HSMD_RX_p7	LVDS RX bit 7 or CMOS I/O	LVDS or 2.5-V	AN32
91	HSMD_TX_n7	LVDS TX bit 7n or CMOS I/O	LVDS or 2.5-V	AE27
92	HSMD_RX_n7	LVDS RX bit 7n or CMOS I/O	LVDS or 2.5-V	AP33
95	HSMD_CLKOUT_p1	LVDS TX or CMOS I/O or differential clock output	LVDS or 2.5-V	W32
96	HSMD_CLKIN_p1	LVDS RX or CMOS input or differential clock input	LVDS or 2.5-V	W34
97	HSMD_CLKOUT_n1	LVDS TX or CMOS I/O or differential clock output	LVDS or 2.5-V	W33
98	HSMD_CLKIN_n1	LVDS RX or CMOS input or differential clock input	LVDS or 2.5-V	W35
101	HSMD_TX_p8	LVDS TX bit 8 or CMOS I/O	LVDS or 2.5-V	AC26
102	HSMD_RX_p8	LVDS RX bit 8 or CMOS I/O	LVDS or 2.5-V	AM31
103	HSMD_TX_n8	LVDS TX bit 8n or CMOS I/O	LVDS or 2.5-V	AD26
104	HSMD_RX_n8	LVDS RX bit 8n or CMOS I/O	LVDS or 2.5-V	AN31
107	HSMD_TX_p9	LVDS TX bit 9 or CMOS I/O	LVDS or 2.5-V	AE26
108	HSMD_RX_p9	LVDS RX bit 9 or CMOS I/O	LVDS or 2.5-V	AN30
109	HSMD_TX_n9	LVDS TX bit 9n or CMOS I/O	LVDS or 2.5-V	AF26
110	HSMD_RX_n9	LVDS RX bit 9n or CMOS I/O	LVDS or 2.5-V	AP30
113	HSMD_TX_p10	LVDS TX bit 10 or CMOS I/O	LVDS or 2.5-V	V29
114	HSMD_RX_p10	LVDS RX bit 10 or CMOS I/O	LVDS or 2.5-V	AP32
115	HSMD_TX_n10	LVDS TX bit 10n or CMOS I/O	LVDS or 2.5-V	V30
116	HSMD_RX_n10	LVDS RX bit 10n or CMOS I/O	LVDS or 2.5-V	AR32
119	HSMD_TX_p11	LVDS TX bit 11 or CMOS I/O	LVDS or 2.5-V	W28
120	HSMD_RX_p11	LVDS RX bit 11 or CMOS I/O	LVDS or 2.5-V	V34
121	HSMD_TX_n11	LVDS TX bit 11n or CMOS I/O	LVDS or 2.5-V	V28
122	HSMD_RX_n11	LVDS RX bit 11n or CMOS I/O	LVDS or 2.5-V	U35
125	HSMD_TX_p12	LVDS TX bit 12 or CMOS I/O	LVDS or 2.5-V	T30
126	HSMD_RX_p12	LVDS RX bit 12 or CMOS I/O	LVDS or 2.5-V	U31
127	HSMD_TX_n12	LVDS TX bit 12n or CMOS I/O	LVDS or 2.5-V	T31
128	HSMD_RX_n12	LVDS RX bit 12n or CMOS I/O	LVDS or 2.5-V	V31
131	HSMD_TX_p13	LVDS TX bit 13 or CMOS I/O	LVDS or 2.5-V	R32
132	HSMD_RX_p13	LVDS RX bit 13 or CMOS I/O	LVDS or 2.5-V	N33
133	HSMD_TX_n13	LVDS TX bit 13n or CMOS I/O	LVDS or 2.5-V	R33
134	HSMD_RX_n13	LVDS RX bit 13n or CMOS I/O	LVDS or 2.5-V	N34
137	HSMD_TX_p14	LVDS TX bit 14 or CMOS I/O	LVDS or 2.5-V	P31

138	HSMD_RX_p14	LVDS RX bit 14 or CMOS I/O	LVDS or 2.5-V	M33
139	HSMD_TX_n14	LVDS TX bit 14n or CMOS I/O	LVDS or 2.5-V	P32
140	HSMD_RX_n14	LVDS RX bit 14n or CMOS I/O	LVDS or 2.5-V	M34
143	HSMD_TX_p15	LVDS TX bit 15 or CMOS I/O	LVDS or 2.5-V	R30
144	HSMD_RX_p15	LVDS RX bit 15 or CMOS I/O	LVDS or 2.5-V	L34
145	HSMD_TX_n15	LVDS TX bit 15n or CMOS I/O	LVDS or 2.5-V	R31
146	HSMD_RX_n15	LVDS RX bit 15n or CMOS I/O	LVDS or 2.5-V	L35
149	HSMD_TX_p16	LVDS TX bit 16 or CMOS I/O	LVDS or 2.5-V	AK31
150	HSMD_RX_p16	LVDS RX bit 16 or CMOS I/O	LVDS or 2.5-V	K34
151	HSMD_TX_n16	LVDS TX bit 16n or CMOS I/O	LVDS or 2.5-V	AL31
152	HSMD_RX_n16	LVDS RX bit 16n or CMOS I/O	LVDS or 2.5-V	K35
155	HSMD_OUT_p2	LVDS TX or CMOS I/O	LVDS or 2.5-V	M32
156	HSMD_CLKIN_p2	LVDS RX or CMOS input or differential clock input	LVDS or 2.5-V	J34
157	HSMD_OUT_n2	LVDS TX or CMOS I/O	LVDS or 2.5-V	L32
158	HSMD_CLKIN_n2	LVDS RX or CMOS I/O or differential clock input	LVDS or 2.5-V	J35

Table 8-5 HSMC Port E Pin Assignments, Schematic Signal Names, and Functions

<i>Board Reference (J3)</i>	<i>Schematic Signal Name</i>	<i>Description</i>	<i>I/O Standard</i>	<i>Stratix IV GX Pin Number</i>
1	HSME_GXB_TX_p7	Transceiver TX bit 7	1.4-V PCML	B36
2	HSME_GXB_RX_p7	Transceiver RX bit 7	1.4-V PCML	C38
3	HSME_GXB_TX_n7	Transceiver TX bit 7n	1.4-V PCML	B37
4	HSME_GXB_RX_n7	Transceiver RX bit 7n	1.4-V PCML	C39
5	HSME_GXB_TX_p6	Transceiver TX bit 6	1.4-V PCML	D36
6	HSME_GXB_RX_p6	Transceiver TX bit 6	1.4-V PCML	E38
7	HSME_GXB_TX_n6	Transceiver TX bit 6n	1.4-V PCML	D37
8	HSME_GXB_RX_n6	Transceiver RX bit 6n	1.4-V PCML	E39
9	HSME_GXB_TX_p5	Transceiver TX bit 5	1.4-V PCML	K36
10	HSME_GXB_RX_p5	Transceiver RX bit 5	1.4-V PCML	L38
11	HSME_GXB_TX_n5	Transceiver RX bit 5n	1.4-V PCML	K37
12	HSME_GXB_RX_n5	Transceiver RX bit 5n	1.4-V PCML	L39
13	HSME_GXB_TX_p4	Transceiver TX bit 4	1.4-V PCML	M36
14	HSME_GXB_RX_p4	Transceiver RX bit 4	1.4-V PCML	N38
15	HSME_GXB_TX_n4	Transceiver TX bit 4n	1.4-V PCML	M37
16	HSME_GXB_RX_n4	Transceiver RX bit 4n	1.4-V PCML	N39
17	HSME_GXB_TX_p3	Transceiver TX bit 3	1.4-V PCML	P36
18	HSME_GXB_RX_p3	Transceiver TX bit 3	1.4-V PCML	R38
19	HSME_GXB_TX_n3	Transceiver TX bit 3n	1.4-V PCML	P37
20	HSME_GXB_RX_n3	Transceiver RX bit 3n	1.4-V PCML	R39

21	HSME_GXB_TX_p2	Transceiver TX bit 2	1.4-V PCML	T36
22	HSME_GXB_RX_p2	Transceiver RX bit 2	1.4-V PCML	U38
23	HSME_GXB_TX_n2	Transceiver RX bit 2n	1.4-V PCML	T37
24	HSME_GXB_RX_n2	Transceiver RX bit 2n	1.4-V PCML	U39
25	HSME_GXB_TX_p1	Transceiver TX bit 1	1.4-V PCML	AB36
26	HSME_GXB_RX_p1	Transceiver RX bit 1	1.4-V PCML	AC38
27	HSME_GXB_TX_n1	Transceiver TX bit 1n	1.4-V PCML	AB37
28	HSME_GXB_RX_n1	Transceiver RX bit 1n	1.4-V PCML	AC39
29	HSME_GXB_TX_p0	Transceiver TX bit 0	1.4-V PCML	AD36
30	HSME_GXB_RX_p0	Transceiver TX bit 0	1.4-V PCML	AE38
31	HSME_GXB_TX_n0	Transceiver TX bit 0n	1.4-V PCML	AD37
32	HSME_GXB_RX_n0	Transceiver RX bit 0n	1.4-V PCML	AE39
39	HSME_OUT0	CMOS I/O	LVDS or 2.5-V	C12
40	HSME_CLKIN0	CMOS I/O	LVDS or 2.5-V	C13
41	HSME_D0	LVDS TX or CMOS I/O	LVDS or 2.5-V	V12
42	HSME_D1	LVDS RX or CMOS I/O	LVDS or 2.5-V	W8
43	HSME_D2	LVDS TX or CMOS I/O	LVDS or 2.5-V	V11
44	HSME_D3	LVDS RX or CMOS I/O	LVDS or 2.5-V	W7
47	HSME_TX_p0	LVDS TX bit 0 or CMOS I/O	LVDS or 2.5-V	V10
48	HSME_RX_p0	LVDS RX bit 0 or CMOS I/O	LVDS or 2.5-V	V6
49	HSME_TX_n0	LVDS TX bit 0n or CMOS I/O	LVDS or 2.5-V	V9
50	HSME_RX_n0	LVDS RX bit 0n or CMOS I/O	LVDS or 2.5-V	U5
53	HSME_TX_p1	LVDS TX bit 1 or CMOS I/O	LVDS or 2.5-V	T10
54	HSME_RX_p1	LVDS RX bit 1 or CMOS I/O	LVDS or 2.5-V	R6
55	HSME_TX_n1	LVDS TX bit 1n or CMOS I/O	LVDS or 2.5-V	R10
56	HSME_RX_n1	LVDS RX bit 1n or CMOS I/O	LVDS or 2.5-V	R5
59	HSME_TX_p2	LVDS TX bit 2 or CMOS I/O	LVDS or 2.5-V	U10
60	HSME_RX_p2	LVDS RX bit 2 or CMOS I/O	LVDS or 2.5-V	R7
61	HSME_TX_n2	LVDS TX bit 2n or CMOS I/O	LVDS or 2.5-V	T9
62	HSME_RX_n2	LVDS RX bit 2n or CMOS I/O	LVDS or 2.5-V	P6
65	HSME_TX_p3	LVDS TX bit 3 or CMOS I/O	LVDS or 2.5-V	R9
66	HSME_RX_p3	LVDS RX bit 3 or CMOS I/O	LVDS or 2.5-V	N6
67	HSME_TX_n3	LVDS TX bit 3n or CMOS I/O	LVDS or 2.5-V	R8
68	HSME_RX_n3	LVDS RX bit 3n or CMOS I/O	LVDS or 2.5-V	N5
71	HSME_TX_p4	LVDS TX bit 4 or CMOS I/O	LVDS or 2.5-V	N9
72	HSME_RX_p4	LVDS RX bit 4 or CMOS I/O	LVDS or 2.5-V	N8

73	HSME_TX_n4	LVDS TX bit 4n or CMOS I/O	LVDS or 2.5-V	P8
74	HSME_RX_n4	LVDS RX bit 4n or CMOS I/O	LVDS or 2.5-V	N7
77	HSME_TX_p5	LVDS TX bit 5 or CMOS I/O	LVDS or 2.5-V	M8
78	HSME_RX_p5	LVDS RX bit 5 or CMOS I/O	LVDS or 2.5-V	M6
79	HSME_TX_n5	LVDS TX bit 5n or CMOS I/O	LVDS or 2.5-V	M7
80	HSME_RX_n5	LVDS RX bit 5n or CMOS I/O	LVDS or 2.5-V	L5
83	HSME_TX_p6	LVDS TX bit 6 or CMOS I/O	LVDS or 2.5-V	L8
84	HSME_RX_p6	LVDS RX bit 6 or CMOS I/O	LVDS or 2.5-V	K6
85	HSME_TX_n6	LVDS TX bit 6n or CMOS I/O	LVDS or 2.5-V	L7
86	HSME_RX_n6	LVDS RX bit 6n or CMOS I/O	LVDS or 2.5-V	K5
89	HSME_TX_p7	LVDS TX bit 7 or CMOS I/O	LVDS or 2.5-V	K7
90	HSME_RX_p7	LVDS RX bit 7 or CMOS I/O	LVDS or 2.5-V	J6
91	HSME_TX_n7	LVDS TX bit 7n or CMOS I/O	LVDS or 2.5-V	J7
92	HSME_RX_n7	LVDS RX bit 7n or CMOS I/O	LVDS or 2.5-V	J5
95	HSME_CLKOUT_p1	LVDS TX or CMOS I/O or differential clock output	LVDS or 2.5-V	W12
96	HSME_CLKIN_p1	LVDS RX or CMOS input or differential clock input	LVDS or 2.5-V	W6
97	HSME_CLKOUT_n1	LVDS TX or CMOS I/O or differential clock output	LVDS or 2.5-V	W11
98	HSME_CLKIN_n1	LVDS RX or CMOS input or differential clock input	LVDS or 2.5-V	W5
101	HSME_TX_p8	LVDS TX bit 8 or CMOS I/O	LVDS or 2.5-V	N13
102	HSME_RX_p8	LVDS RX bit 8 or CMOS I/O	LVDS or 2.5-V	P14
103	HSME_TX_n8	LVDS TX bit 8n or CMOS I/O	LVDS or 2.5-V	M13
104	HSME_RX_n8	LVDS RX bit 8n or CMOS I/O	LVDS or 2.5-V	N14
107	HSME_TX_p9	LVDS TX bit 9 or CMOS I/O	LVDS or 2.5-V	M14
108	HSME_RX_p9	LVDS RX bit 9 or CMOS I/O	LVDS or 2.5-V	L13
109	HSME_TX_n9	LVDS TX bit 9n or CMOS I/O	LVDS or 2.5-V	K12
110	HSME_RX_n9	LVDS RX bit 9n or CMOS I/O	LVDS or 2.5-V	K13
113	HSME_TX_p10	LVDS TX bit 10 or CMOS I/O	LVDS or 2.5-V	D11
114	HSME_RX_p10	LVDS RX bit 10 or CMOS I/O	LVDS or 2.5-V	L14

		I/O		
115	HSME_TX_n10	LVDS TX bit 10n or CMOS I/O	LVDS or 2.5-V	B10
116	HSME_RX_n10	LVDS RX bit 10n or CMOS I/O	LVDS or 2.5-V	K14
119	HSME_TX_p11	LVDS TX bit 11 or CMOS I/O	LVDS or 2.5-V	A10
120	HSME_RX_p11	LVDS RX bit 11 or CMOS I/O	LVDS or 2.5-V	H13
121	HSME_TX_n11	LVDS TX bit 11n or CMOS I/O	LVDS or 2.5-V	C11
122	HSME_RX_n11	LVDS RX bit 11n or CMOS I/O	LVDS or 2.5-V	G13
125	HSME_TX_p12	LVDS TX bit 12 or CMOS I/O	LVDS or 2.5-V	J12
126	HSME_RX_p12	LVDS RX bit 12 or CMOS I/O	LVDS or 2.5-V	F13
127	HSME_TX_n12	LVDS TX bit 12n or CMOS I/O	LVDS or 2.5-V	J13
128	HSME_RX_n12	LVDS RX bit 12n or CMOS I/O	LVDS or 2.5-V	E13
131	HSME_TX_p13	LVDS TX bit 13 or CMOS I/O	LVDS or 2.5-V	F12
132	HSME_RX_p13	LVDS RX bit 13 or CMOS I/O	LVDS or 2.5-V	B11
133	HSME_TX_n13	LVDS TX bit 13n or CMOS I/O	LVDS or 2.5-V	D13
134	HSME_RX_n13	LVDS RX bit 13n or CMOS I/O	LVDS or 2.5-V	A11
137	HSME_TX_p14	LVDS TX bit 14 or CMOS I/O	LVDS or 2.5-V	B14
138	HSME_RX_p14	LVDS RX bit 14 or CMOS I/O	LVDS or 2.5-V	F14
139	HSME_TX_n14	LVDS TX bit 14n or CMOS I/O	LVDS or 2.5-V	A14
140	HSME_RX_n14	LVDS RX bit 14n or CMOS I/O	LVDS or 2.5-V	E14
143	HSME_TX_p15	LVDS TX bit 15 or CMOS I/O	LVDS or 2.5-V	H14
144	HSME_RX_p15	LVDS RX bit 15 or CMOS I/O	LVDS or 2.5-V	B13
145	HSME_TX_n15	LVDS TX bit 15n or CMOS I/O	LVDS or 2.5-V	G14
146	HSME_RX_n15	LVDS RX bit 15n or CMOS I/O	LVDS or 2.5-V	A13
149	HSME_TX_p16	LVDS TX bit 16 or CMOS I/O	LVDS or 2.5-V	K15
150	HSME_RX_p16	LVDS RX bit 16 or CMOS I/O	LVDS or 2.5-V	D14
151	HSME_TX_n16	LVDS TX bit 16n or CMOS I/O	LVDS or 2.5-V	J15

		I/O		
152	HSME_RX_n16	LVDS RX bit 16n or CMOS I/O	LVDS or 2.5-V	C14
155	HSME_OUT_p2	LVDS TX or CMOS I/O	LVDS or 2.5-V	R14
156	HSME_CLKIN_p2	LVDS RX or CMOS input or differential clock input	LVDS or 2.5-V	AB6
157	HSME_OUT_n2	LVDS TX or CMOS I/O	LVDS or 2.5-V	N15
158	HSME_CLKIN_n2	LVDS RX or CMOS input or differential clock input	LVDS or 2.5-V	AA5

Table 8-6 HSMC Port F Pin Assignments, Schematic Signal Names, and Functions

<i>Board Reference (J16)</i>	<i>Schematic Signal Name</i>	<i>Description</i>	<i>I/O Standard</i>	<i>Stratix IV GX Pin Number</i>
39	HSMF_OUT0	CMOS I/O	2.5-V	AP20
40	HSMF_CLKIN0	Dedicated clock input	2.5-V	AV22
41	HSMF_D0	CMOS I/O	2.5-V	AU25
42	HSMF_D1	CMOS I/O	2.5-V	AV26
43	HSMF_D2	CMOS I/O	2.5-V	AT25
44	HSMF_D3	CMOS I/O	2.5-V	AW26
47	HSMF_TX_p0	CMOS I/O	2.5-V	AV25
48	HSMF_RX_p0	CMOS I/O	2.5-V	AT26
49	HSMF_TX_n0	CMOS I/O	2.5-V	AW25
50	HSMF_RX_n0	CMOS I/O	2.5-V	AU26
53	HSMF_TX_p1	CMOS I/O	2.5-V	AR25
54	HSMF_RX_p1	CMOS I/O	2.5-V	AT24
55	HSMF_TX_n1	CMOS I/O	2.5-V	AP25
56	HSMF_RX_n1	CMOS I/O	2.5-V	AU24
59	HSMF_TX_p2	CMOS I/O	2.5-V	AV23
60	HSMF_RX_p2	CMOS I/O	2.5-V	AN24
61	HSMF_TX_n2	CMOS I/O	2.5-V	AW23
62	HSMF_RX_n2	CMOS I/O	2.5-V	AP24
65	HSMF_TX_p3	CMOS I/O	2.5-V	AP23
66	HSMF_RX_p3	CMOS I/O	2.5-V	AT23
67	HSMF_TX_n3	CMOS I/O	2.5-V	AR23
68	HSMF_RX_n3	CMOS I/O	2.5-V	AU23
71	HSMF_TX_p4	CMOS I/O	2.5-V	AM23
72	HSMF_RX_p4	CMOS I/O	2.5-V	AR20
73	HSMF_TX_n4	CMOS I/O	2.5-V	AN23
74	HSMF_RX_n4	CMOS I/O	2.5-V	AT20
77	HSMF_TX_p5	CMOS I/O	2.5-V	AN25
78	HSMF_RX_p5	CMOS I/O	2.5-V	AT22
79	HSMF_TX_n5	CMOS I/O	2.5-V	AM25
80	HSMF_RX_n5	CMOS I/O	2.5-V	AU22
83	HSMF_TX_p6	CMOS I/O	2.5-V	AL22

84	HSMF_RX_p6	CMOS I/O	2.5-V	AU20
85	HSMF_TX_n6	CMOS I/O	2.5-V	AL21
86	HSMF_RX_n6	CMOS I/O	2.5-V	AV20
89	HSMF_TX_p7	CMOS I/O	2.5-V	AR19
90	HSMF_RX_p7	CMOS I/O	2.5-V	AT19
91	HSMF_TX_n7	CMOS I/O	2.5-V	AP19
92	HSMF_RX_n7	CMOS I/O	2.5-V	AU19
95	HSMF_CLKOUT_p1	CMOS I/O	2.5-V	AN21
96	HSMF_CLKIN_p1	CMOS input	2.5-V	AW20
97	HSMF_CLKOUT_n1	CMOS I/O	2.5-V	AP21
98	HSMF_CLKIN_n1	CMOS input	2.5-V	AW21
101	HSMF_TX_p8	CMOS I/O	2.5-V	AT17
102	HSMF_RX_p8	CMOS I/O	2.5-V	AT18
103	HSMF_TX_n8	CMOS I/O	2.5-V	AW18
104	HSMF_RX_n8	CMOS I/O	2.5-V	AU18
107	HSMF_TX_p9	CMOS I/O	2.5-V	AN19
108	HSMF_RX_p9	CMOS I/O	2.5-V	AU17
109	HSMF_TX_n9	CMOS I/O	2.5-V	AM19
110	HSMF_RX_n9	CMOS I/O	2.5-V	AV17
113	HSMF_TX_p10	CMOS I/O	2.5-V	AJ22
114	HSMF_RX_p10	CMOS I/O	2.5-V	AM22
115	HSMF_TX_n10	CMOS I/O	2.5-V	AK24
116	HSMF_RX_n10	CMOS I/O	2.5-V	AN22
119	HSMF_TX_p11	CMOS I/O	2.5-V	AE23
120	HSMF_RX_p11	CMOS I/O	2.5-V	AN18
121	HSMF_TX_n11	CMOS I/O	2.5-V	AH22
122	HSMF_RX_n11	CMOS I/O	2.5-V	AP18
125	HSMF_TX_p12	CMOS I/O	2.5-V	AF23
126	HSMF_RX_p12	CMOS I/O	2.5-V	AK23
127	HSMF_TX_n12	CMOS I/O	2.5-V	AE22
128	HSMF_RX_n12	CMOS I/O	2.5-V	AL23
131	HSMF_TX_p13	CMOS I/O	2.5-V	AG21
132	HSMF_RX_p13	CMOS I/O	2.5-V	AH23
133	HSMF_TX_n13	CMOS I/O	2.5-V	AE21
134	HSMF_RX_n13	CMOS I/O	2.5-V	AJ23
137	HSMF_TX_p14	CMOS I/O	2.5-V	AD21
138	HSMF_RX_p14	CMOS I/O	2.5-V	AF22
139	HSMF_TX_n14	CMOS I/O	2.5-V	AG20
140	HSMF_RX_n14	CMOS I/O	2.5-V	AG22
143	HSMF_TX_p15	CMOS I/O	2.5-V	AG18
144	HSMF_RX_p15	CMOS I/O	2.5-V	AE20
145	HSMF_TX_n15	CMOS I/O	2.5-V	AE18
146	HSMF_RX_n15	CMOS I/O	2.5-V	AF20

149	HSMF_TX_p16	CMOS I/O	2.5-V	AD19
150	HSMF_RX_p16	CMOS I/O	2.5-V	AE19
151	HSMF_TX_n16	CMOS I/O	2.5-V	AG19
152	HSMF_RX_n16	CMOS I/O	2.5-V	AF19
155	HSMF_OUT_p2	CMOS I/O	2.5-V	AH20
156	HSMF_CLKIN_p2	CMOS input	2.5-V	AR22
157	HSMF_OUT_n2	CMOS I/O	2.5-V	AJ20
158	HSMF_CLKIN_n2	CMOS input	2.5-V	AT21

Additional Information

Getting Help

Here is the contact information where you can get help if you encounter problems:

- Terasic Technologies
9F, No.176, Sec.2, Gongdao 5th Rd, East Dist, Hsinchu City, Taiwan 300-70
Email : support@terasic.com
Web : www.terasic.com

Revision History

Date	Version	Changes
2011.12.29	First publication	
2012.03.01	V1.1	Update PCA Card
2012.03.08	V1.2	Update PCIe driver
2013.09.10	V1.3	Update HSMC pin table
2014.2.10	V1.4	Swap pin assignment of hsmc table. HSMC_RX_n0 , HSMC_RX_p0
2014.3.18	V1.5	Modify table2-7 and HSMC feature
2015.01.07	V1.6	Update FPGA embedded ram size
2015.06.03	V1.7	Modify table 7-6 to change i/o standard to CMOS I/O and 2.5V
2016.08.11	V1.8	Add Section 2.15 Using External Blaster
2017.03.30	V1.9	Remove Altera Logo
2018.06.06	V2.0	Modify DDR3 SO-DIMM socket maximum capacity from 4G to 8G

2021.01.20	V2.1	<ol style="list-style-type: none">1. Update demonstrations to Quartus 20.12. Add PCIE demo
------------	------	-------------------------------------------------------------------------------------------------------------------