

CC400

Single Chip High Performance RF Transceiver

Applications

- UHF wireless data transmitters and receivers
- Wireless alarm and security systems
- 315 / 426 / 429 / 433 MHz ISM/SRD band systems
- Point of sale terminals
- Remote control systems
- Home security and automation
- Low power telemetry
- AMR – Automatic Meter Reading
- Environmental control

Product Description

CC400 is a single-chip high performance, half-duplex, FSK, UHF transceiver designed for low power and low-voltage wireless applications. The circuit is mainly intended for the ISM (Industrial, Scientific and Medical) frequency bands at 315, 418 and 433 MHz, but can easily be programmed for operation at other frequency bands in the 300 - 500 MHz range.

The main operating parameters of **CC400** can be programmed via a serial interface, thus making **CC400** a very flexible and easy to use component. In a typical system **CC400** will be used together with a microcontroller and a few external passive components.

CC400 is based on Chipcon's SmartRF® technology.

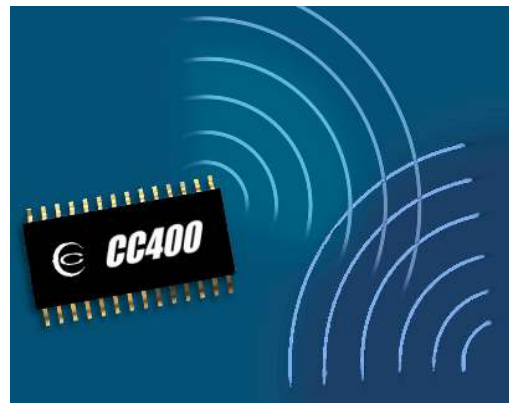

Features

- Single chip RF transceiver
- Frequency range 300 – 500 MHz
- High sensitivity (typical -110 dBm)
- Programmable output power up to 25 mW (14 dBm)
- Small size (SSOP-28 package)
- Low supply voltage (2.7 V to 3.3 V)
- Very few external components required
- FSK modulation
- Very low phase noise
- Data-rate up to 9.6 kbps
- Suitable for both narrow and wide band systems
- Suitable for frequency hopping protocols
- Frequency-Lock indicator
- Development kit available
- Easy-to-use software (SmartRF Studio) for generating the **CC400** configuration data

Table of Contents

1.	ABSOLUTE MAXIMUM RATINGS	4
2.	OPERATING CONDITIONS	4
3.	ELECTRICAL SPECIFICATIONS	4
4.	GENERAL CHARACTERISTICS	5
5.	RF RECEIVE SECTION	5
6.	RF TRANSMIT SECTION	6
7.	IF SECTION	6
8.	FREQUENCY SYNTHESIZER SECTION	7
9.	DC CHARACTERISTICS	7
10.	PIN ASSIGNMENT	8
11.	CIRCUIT DESCRIPTION	9
12.	CONFIGURATION OVERVIEW	10
13.	CONFIGURATION SOFTWARE	10
14.	3-WIRE SERIAL INTERFACE	11
15.	MICROCONTROLLER INTERFACE	13
15.1.	CONNECTING THE MICROCONTROLLER	13
15.2.	DATA TRANSMISSION	13
15.3.	DATA RECEPTION	13
16.	APPLICATION CIRCUIT	14
16.1.	INPUT / OUTPUT MATCHING	14
16.2.	SYNTHESIZER LOOP FILTER AND VCO TANK	14
16.3.	ADDITIONAL FILTERING	14
16.4.	VOLTAGE SUPPLY DECOUPLING	14
17.	RECEIVER SENSITIVITY	15
18.	OUTPUT POWER	16
19.	INPUT / OUTPUT MATCHING	16
20.	OPTIONAL LC FILTER	17
21.	CRYSTAL OSCILLATOR	17
22.	LOOP FILTER	18
23.	BLOCKING	18
24.	PLL LOCK INDICATOR	19
25.	ANTENNA CONSIDERATIONS	19
26.	SYSTEM CONSIDERATIONS AND GUIDELINES	20
26.1.	LOW-COST SYSTEMS	20
26.2.	BATTERY OPERATED SYSTEMS	20
26.3.	NARROW BAND SYSTEMS	20
26.4.	HIGH RELIABILITY SYSTEMS	20
26.5.	SPREAD SPECTRUM FREQUENCY HOPPING SYSTEMS	20
27.	DEMODULATOR PRECHARGING FOR REDUCED TURN-ON TIME	21
28.	PCB LAYOUT RECOMMENDATIONS	22

29.	CONFIGURATION REGISTERS.....	22
30.	PACKAGE DESCRIPTION (SSOP-28)	28
31.	SOLDERING INFORMATION	28
32.	PLASTIC TUBE SPECIFICATION.....	29
33.	CARRIER TAPE AND REEL SPECIFICATION	29
34.	ORDERING INFORMATION	29
35.	GENERAL INFORMATION	30
35.1.	DOCUMENT HISTORY	30
35.2.	PRODUCT STATUS DEFINITIONS	30
35.3.	DISCLAIMER	30
35.4.	TRADEMARKS	31
35.5.	LIFE SUPPORT POLICY	31
36.	ADDRESS INFORMATION.....	32

1. Absolute Maximum Ratings

The absolute maximum ratings given in Table 1 must under no circumstances be violated. Stress exceeding one or more of the limiting values may cause permanent damage to the device.

Parameter	Min.	Max.	Units	Condition
Supply voltage, VDD	-0.3	7.0	V	
Voltage on any pin	-0.3	VDD+0.3, max 7.0	V	
Input RF level		10	dBm	
Storage temperature range	-50	150	°C	
Reflow solder temperature		260	°C	T = 10 s

Table 1: Absolute Maximum Ratings



Caution! ESD sensitive device.
Precaution should be used when handling the device in order to prevent permanent damage.

2. Operating Conditions

The operating conditions for **CC400** are listed in Table 2 below.

Parameter	Min.	Max.	Units	Condition
Operating ambient temperature	-30	85	°C	

Table 2: Operating Conditions

3. Electrical Specifications

T_c = 25°C, VDD = 3.0V if nothing else stated. Measured on Chipcon's **CC400DB** reference design.

Parameter	Min.	Typ.	Max.	Unit	Condition
Supply voltage		3.0		V	Recommended operation voltage
	2.7		3.3	V	Operating limits
Current Consumption, receive mode		23		mA	
Current Consumption, average in receive mode using polling		230		μA	1:100 receive to power down ratio
Current Consumption, transmit mode:					The output power is delivered to a 50 Ω load
P=1 mW (0 dBm)		33		mA	
P=4 mW (6 dBm)		44		mA	
P=10 mW (10 dBm)		59		mA	
P=20 mW (13 dBm)		68		mA	
P=25 mW (14 dBm)		77		mA	
Current Consumption, Power Down		23		μA	Oscillator core on
		0.2	2	μA	Oscillator core off

Table 3: Electrical Specifications

4. General Characteristics

The general characteristics of **CC400** are listed in Table 4 below.

Parameter	Min.	Typ.	Max.	Unit	Condition
RF Frequency Range	300	315 418 433.92	500	MHz	Programmable in steps of 250 Hz
Transmit data rate	0.3	2.4	9.6	kbps	Manchester code is required. (9.6 kbps equals 19.2 kBaud using Manchester code)

Table 4: General Characteristics

5. RF Receive Section

T_c = 25°C, VDD = 3.0V if nothing else stated. Measured on Chipcon's **CC400DB** reference design.

Parameter	Min.	Typ.	Max.	Unit	Condition
Receiver Sensitivity		-110		dBm	Measured at 433.92 MHz and a data rate of 1.2 kbps, 60 kHz IF and 20 kHz frequency separation with a bit error rate better than 10 ⁻³ . For other settings see p.15.
Cascaded noise figure		3		dB	
LO leakage		-39		dBm	Measured conducted on CC400DB. Radiated LO leakage depends on external components placement.
Input impedance		39 Ω +4.9 pF			Receive mode, series equivalent. For matching details see "Input/output matching" p. 16.
Turn on time		500 3 5 30		μs ms ms ms	With precharging, 9.6 kbps Without precharging, 9.6 kbps With precharging, 1.2 kbps Without precharging, 1.2 kbps See "Demodulator precharging for reduced turn-on time" p. 21.
Blocking / Desensitization					Complies with EN 300 220 class 2 receiver requirements. See p. 18 for more details.
±1 MHz	30			dB	
±2 MHz	35			dB	
±5 MHz	50			dB	
±10 MHz	60			dB	

Table 5: RF Receive Section

6. RF Transmit Section

T_c = 25°C, VDD = 3.0V if nothing else stated. Measured on Chipcon's **CC400DB** reference design.

Parameter	Min.	Typ.	Max.	Unit	Condition
Binary FSK frequency separation	0	10	200	kHz	The frequency corresponding to the digital "0" is denoted f_0 , while f_1 corresponds to a digital "1". The frequency separation is $f_1 - f_0$. The RF carrier frequency, f_c , is then given by $f_c = (f_0 + f_1) / 2$. (The frequency deviation is given by $f_d = \pm (f_1 - f_0) / 2$) The frequency separation is programmable in steps of 1 kHz.
Programmable output power	-5		14	dBm	Delivered to matched load. The output power is programmable in steps of 1 dB.
RF output impedance		400 Ω 3 pF			Transmit mode, parallel equivalent. For matching details see "Input/ output matching" p.16.
Harmonics		-30		dBc	When transmitting high output power levels an external LC or SAW filter may be used to reduce harmonics emission to comply with ISM requirements. See p. 17.

Table 6: RF Transmit Section

7. IF Section

Parameter	Min.	Typ.	Max.	Unit	Condition
Intermediate frequency (IF)		60 200 455		kHz kHz kHz	The IF is programmable. Either 60 kHz, 200 kHz or 455 kHz can be chosen. An optional external IF filter can be used if 455 kHz is chosen. The impedance level is 1.5 kΩ

Table 7: IF Section

8. Frequency Synthesiser Section

T_c = 25°C @ VDD = 3.0 V if nothing else is stated. Measured on Chipcon's **CC400DB** reference design.

Parameter	Min.	Typ.	Max.	Unit	Condition
Crystal Oscillator Frequency	4	12	13	MHz	
Crystal frequency accuracy requirement		+/- 50		ppm	The crystal frequency accuracy and drift (ageing and temperature dependency) will determine the frequency accuracy of the transmitted signal.
Crystal operation		Parallel			C151 and C161 are loading capacitors, see page 17.
Crystal load capacitance			20 16 12	pF pF pF	4-6 MHz 6-10 MHz 10-13 MHz
Crystal oscillator start-up time		3	6	ms	12 MHz, 12 pF load
Output signal phase noise		-70 -90		dBc/Hz dBc/Hz	10 kHz offset from carrier 100 kHz offset from carrier Loop filter BW = 16 kHz
		-81 -107		dBc/Hz dBc/Hz	10 kHz offset from carrier 100 kHz offset from carrier Loop filter BW = 3 kHz
RX / TX turn time		100		µs	
PLL turn-on time, crystal oscillator off in power down mode		4		ms	
PLL turn-on time, crystal oscillator on in power down mode		2		ms	It is recommended to wait at least 8 ms (6 ms crystal oscillator start-up time and 2 ms PLL turn-on time) before checking the PLL Lock Indicator at the LOCK pin. Please refer to chapter "PLL Lock Indicator" on page 16 for a further description.

Table 8: Frequency Synthesiser Section

9. DC Characteristics

The DC Characteristics of **CC400** are listed in Table 10 below. T_c = 25°C if nothing else stated.

Parameter	Min.	Typ.	Max.	Unit	Condition
Logic "0" input voltage	0		0.3*VDD	V	
Logic "1" input voltage	0.7*VDD		VDD	V	
Logic "0" output voltage	0		0.4	V	Output current -2.5 mA, 3.0 V supply voltage
Logic "1" output voltage	2.5		VDD	V	Output current 2.5 mA, 3.0 V supply voltage
Logic "0" input current	NA		-1	µA	Input signal equals GND
Logic "1" input current	NA		1	µA	Input signal equals VDD

Table 9: DC Characteristics

10. Pin Assignment

Pin no.	Pin name	Pin type	Description
1	AVDD	Power (A)	Power supply (3V) for analog modules (Mixer, IF, demodulator)
2	AGND	Ground (A)	Ground connection (0V) for analog modules (substrate)
3	AGND	Ground (A)	Ground connection (0V) for analog modules (Mixer, IF, demodulator)
4	AGND	Ground (A)	Ground connection (0V) for analog modules (LNA and PA)
5	RF_IN	RF Input	RF signal input from antenna (external ac-coupling)
6	RF_OUT	RF output	RF signal output to antenna (external bias)
7	AVDD	Power (A)	Power supply (3V) for analog modules (LNA and PA)
8	AVDD	Power (A)	Power supply (3V) for analog modules (VCO)
9	VCO_IN	Analog input	External VCO-tank input
10	AGND	Ground (A)	Ground connection (0V) for analog modules (VCO)
11	AGND	Ground (A)	Ground connection (0V) for analog modules (Prescaler)
12	CHP_OUT	Analog output	Charge pump current output
13	AVDD	Power (A)	Power supply (3V) for analog modules (Prescaler)
14	AVDD	Power (A)	Power supply (3V) for analog modules (XOSC)
15	XOSC_Q1	Analog input	Crystal, pin 1, or external clock input
16	XOSC_Q2	Analog output	Crystal, pin 2
17	AGND	Ground (A)	Ground connection (0V) for analog modules (XOSC)
18	DGND	Ground (D)	Ground connection (0V) for digital modules (substrate)
19	LOCK	Digital output	PLL Lock Indicator. Output is high when PLL is in lock. Please refer to chapter "PLL Lock Indicator" on page 16 for a further description.
20	DGND	Ground (D)	Ground connection (0V) for digital modules (Digital)
21	DVDD	Power (D)	Power supply (3V) for digital modules (Digital)
22	DVDD	Power (D)	Power supply (3V) for digital modules (Guard)
23	DIO	Digital input/output (bi-directional)	Data input in transmit mode Demodulator output in receive mode
24	CLOCK	Digital input	Programming clock for 3-wire bus
25	PDATA	Digital input	Programming data for 3-wire bus
26	STROBE	Digital input	Programming strobe (Load) for 3-wire bus
27	IF_IN	Analog input	Input to IF chain (from external ceramic filter). The input impedance is 1.5 kΩ so a direct connection to an external ceramic filter is possible
28	IF_OUT	Analog output	Output from first amplifier in IF-chain (to external ceramic filter). The output impedance is 1.5 kΩ so a direct connection to an external ceramic filter is possible

A=Analog, D=Digital

Figure 1: Pin-out top view

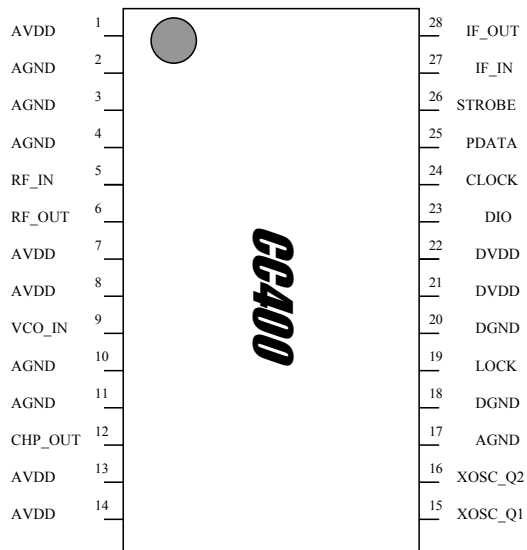

11. Circuit Description

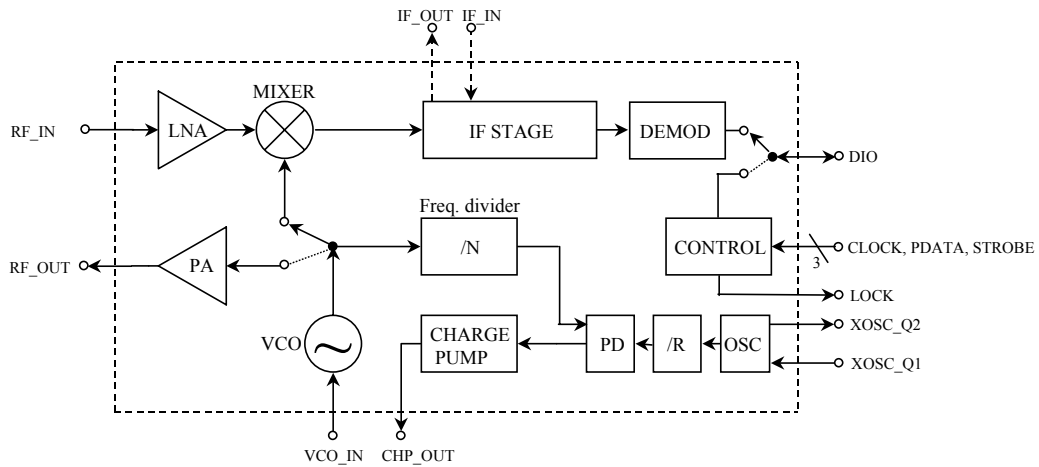

Figure 2: Simplified block diagram of the **CC400**.

A simplified block diagram of **CC400** is shown in Figure 2. Only signal pins are shown.

In receive mode **CC400** is configured as a traditional heterodyne receiver. The RF input signal is amplified by the low-noise amplifier (LNA) and converted down to the intermediate frequency (IF) by the mixer (MIXER). In the intermediate frequency stage (IF STAGE) this downconverted signal is amplified and filtered before being fed to the demodulator (DEMOD). As an option an external IF filter can be used for improved performance. After demodulation **CC400** outputs the raw digital demodulated data on the pin DIO. Synchronisation and final qualification of the demodulated data is done by the interfacing digital system (microcontroller).

In transmit mode the voltage controlled oscillator (VCO) output signal is fed

directly to the power amplifier (PA). The RF output is frequency shift keyed (FSK) by the digital bit stream fed to the pin DIO. The internal T/R switch circuitry makes the antenna interface and matching very easy.

The frequency synthesiser generates the local oscillator signal which is fed to the MIXER in receive mode and to PA in transmit mode. The frequency synthesiser consists of a crystal oscillator (XOSC), phase detector (PD), charge pump (CHARGE PUMP), VCO, and frequency dividers (/R and /N). An external crystal must be connected to XOSC, and an external LC-tank with a varactor diode is required for the VCO. For flexibility the loop filter is external.

For chip configuration **CC400** includes a 3-wire digital serial interface (CONTROL).

12. Configuration Overview

CC400 can be configured to achieve the best performance for different applications. Through the programmable configuration registers the following key parameters can be programmed:

- Receive/Transmit mode.
- RF output power level.
- Power amplifier operation class (A, AB, B or C).
- Frequency synthesiser key parameters: RF output frequency, FSK modulation frequency separation (deviation), crystal oscillator reference frequency.
- Power-down/power-up mode.
- Reference oscillator on or off in power down mode (when on, shorter frequency synthesiser start-up time is achieved).
- The IF (intermediate frequency) can be set to either 60 kHz or 200 kHz using on-chip filters, or 455 kHz using an external filter.
- Data rate can be selected.
- Synthesiser lock indicator mode. The lock detection can be enabled/disabled. When enabled, two lock detection modes can be chosen, either "mono-stable" or continuous.
- In receive mode precharging of the demodulator can be used to achieve faster settling time (see p.21).

13. Configuration Software

Chipcon will provide users of **CC400** with a program, SmartRF Studio (Windows interface) that generates all necessary **CC400** configuration data based on the user's selections of various parameters. Based on the selections 8 hexadecimal numbers are generated. These hexadecimal numbers will then be the necessary input to the microcontroller for

configuration of **CC400**. In addition the program will provide the user with the component values needed for the PLL loop filter and the input/output matching circuit.

Figure 3 shows the user interface of the **CC400** configuration software.

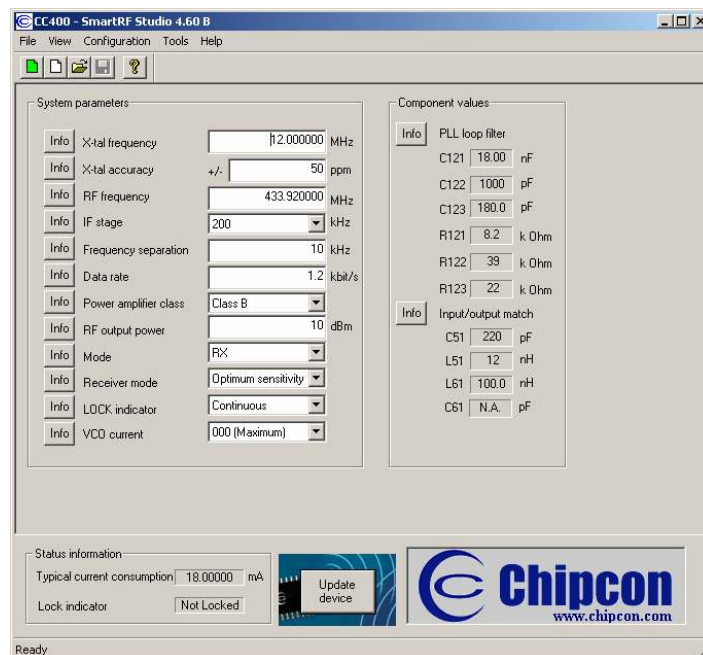

Figure 3: SmartRF Studio user interface.

14. 3-wire Serial Interface

CC400 is programmed via a simple 3-wire interface (STROBE, PDATA and CLOCK). A full configuration of **CC400** requires sending 8 data frames of 16 bits each. With a clock rate of 2 MHz the time needed for a full configuration will therefore be less than 100 μ s. Setting the device in power down mode requires sending one frame only and will therefore take less than 10 μ s.

In each write-cycle 16 bits are sent on the PDATA-line. The three most significant bits of each data frame (*bit15*, *bit14* and *bit13*) are the address-bits. *Bit15* is the MSB of the address and is sent as the first bit. See Figure 4.

A timing diagram for the programming is shown in Figure 5. The clocking of the data on PDATA is done on the negative edge of CLOCK. When the last bit, *bit0*, of the sixteen bits has been loaded, the STROBE-pulse must be brought high and then low to load the data.

The configuration data will be valid after a programmed power-down mode, but not when the power-supply is turned off. When changing mode, only the frames that are different need to be programmed.

The timing specifications are given in Table 10.

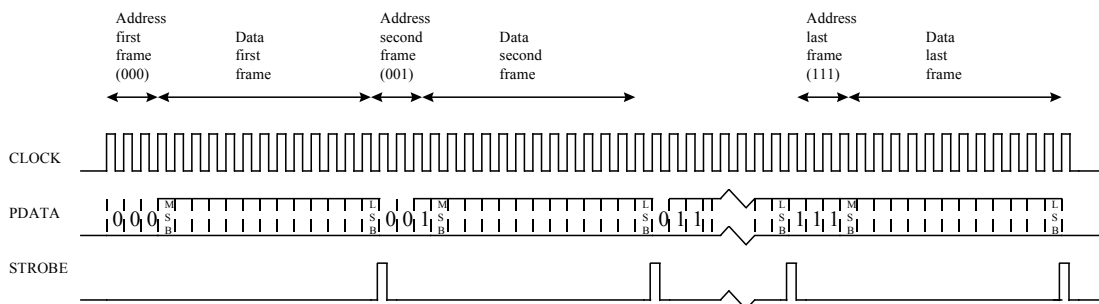

Figure 4: Serial data transfer (full configuration).

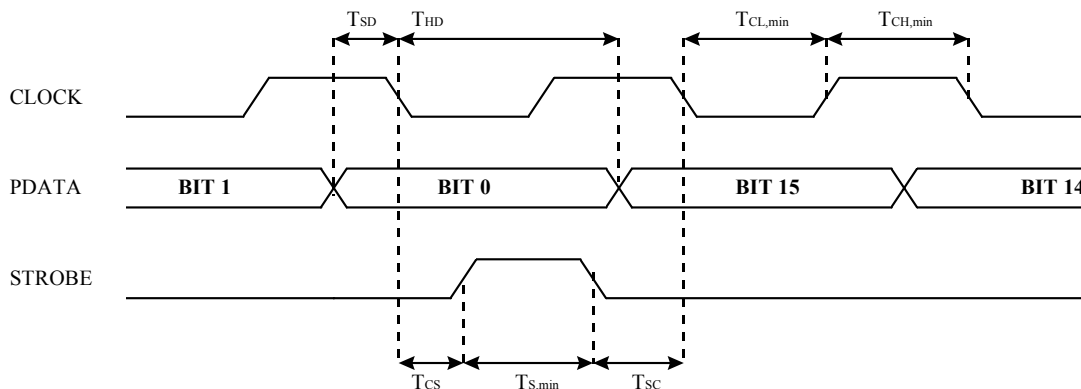

Figure 5: Timing diagram, serial interface.

Parameter	Symbol	Min	Max	Units	Conditions
CLOCK, clock frequency	F_{CLOCK}	-	2	MHz	
CLOCK low pulse duration	$T_{\text{CL,min}}$	50		ns	The minimum time CLOCK can be low.
CLOCK high pulse duration	$T_{\text{CH,min}}$	50		ns	The minimum time CLOCK can be high.
PDATA setup time	T_{SD}	5	-	ns	The minimum time data on PDATA must be ready before the negative edge of CLOCK.
PDATA hold time	T_{HD}	5	-	ns	The minimum time data must be held at PDATA, after the negative edge of CLOCK.
CLOCK to STROBE time	T_{CS}	5	-	ns	The minimum time after the negative edge of CLOCK before positive edge of STROBE.
STROBE to CLOCK time	T_{SC}	5	-	ns	The minimum time after the negative edge of STROBE before negative edge of CLOCK.
STROBE pulse duration	$T_{\text{S,min}}$	50		ns	The minimum time STROBE can be high.
Rise time	T_{rise}		100	ns	The maximum rise time for CLOCK and STROBE
Fall time	T_{fall}		100	ns	The maximum fall time for CLOCK and STROBE

Note: The set-up- and hold-times refer to 50% of VDD.

Table 10: Serial interface, timing specification.

15. Microcontroller Interface

Used in a typical system, **CC400** will interface to a microcontroller. This microcontroller must be able to:

- Program the **CC400** into different modes via the 3-wire serial interface (PDATA, STROBE, CLOCK).
- Operate with the bidirectional data pin DIO.
- Perform oversampling of the demodulator output (on pin DIO), recover the clock corresponding to the actual datarate, and perform data quali-

fication (on Manchester encoded data).

- Data to be sent must be Manchester encoded.
- Optionally the microcontroller can monitor the frequency lock status from pin LOCK.
- Optionally the microcontroller can perform precharging of the receiver in order to reduce the turn-on time (see p.21).

15.1. Connecting the microcontroller

The microcontroller uses 3 output pins for the serial interface (PDATA, STROBE and CLOCK). A bi-directional pin is used for data to be transmitted and data received (DIO). Optionally another pin can be used to monitor the LOCK signal. This signal is logic level high when the PLL is in lock. See Figure 7.

15.2. Data transmission

The data to be sent has to be Manchester encoded (also known as bi-phase-level coding). The Manchester code ensures that the signal has a constant DC component that is necessary for the FSK demodulator. The Manchester code is based on transitions; a “0” is encoded as a low-to-high transition, a “1” is encoded as a high-to-low transition. See Figure 6. When the DIO is logic level high, the upper FSK frequency is transmitted. The lower frequency is transmitted when DIO is low.

Note that the receiver data output is inverted when using low-side LO, which is default using SmartRF Studio.

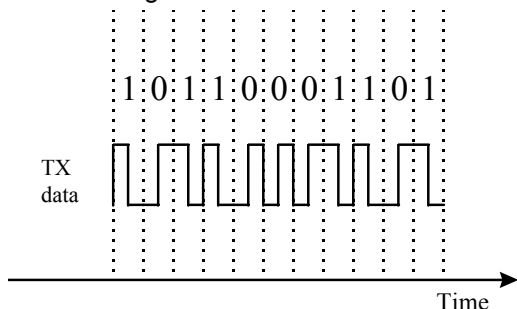

Figure 6: Manchester encoding.

15.3. Data reception

The output of the demodulator (DIO) is a digital signal (alternating between 0 V and VDD). For small input signals, there will be some noise on this signal, located at the edges of the digital signal. The datarate of this signal may be up to 9.6 kbps. Due to the Manchester coding, the fundamental frequency of the signal is also 9.6 kHz. An oversampling of 4-8 times the frequency of the demodulator-output is recommended. I.e. the sampling frequency should be at least 40-80 kHz for 9.6 kbps. For a lower datarate the sampling frequency can be reduced.

In a typical application the data output is sampled by the microcontroller, and stored in an accumulating register. The length of this register will typically be 4-8 bits (depending on the oversampling ratio). The qualification of the data (decide whether the signal is “0” or “1”) can be based on comparing the number of 0’s with the number of 1’s. See Application Note AN008 “Oversampling and data decision for the CC400/CC900” for more details.

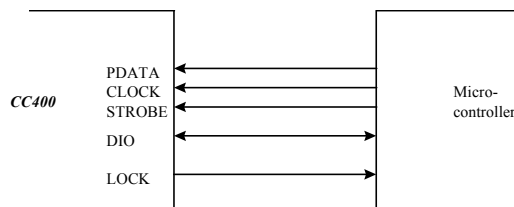

Figure 7: Microcontroller interface.

Item	Description
C10	1 nF, X7R, 0603
C11	33 nF, X7R, 0603
C12	4.7 nF, NP0, 1206
C24	33 pF, NP0, 0603
C25	220 pF, NP0, 0603
C51	220 pF, NP0, 0603
C61	12 pF, NP0, 0603
C91	4.7 pF, NP0, 06035
C92	8.2 pF, NP0, 0603
C93	3.9 pF, NP0, 0603
C121	33 nF, X7R, 0603
C122	1.5 nF, X7R, 0603
C123	330 pF, NP0, 0603
C161	15 pF, NP0, 0603
C151	15 pF, NP0, 0603
C210	1 nF, X7R, 0603
C211	33 nF, X7R, 0603
L51	39 nH, 0805
L61	6.8 nH, 0805
L91	10 nH, 0805
R7	10 kΩ, 0603 (optional)
R121	5.6 kΩ, 0603
R122	27 kΩ, 0603
R123	22 kΩ, 0603
VAR	KV1837K, TOKO or similar
XTAL	12 MHz crystal, 12 pF load

Table 11: Bill of materials for the application circuit.

17. Receiver sensitivity

The receiver sensitivity depends on which IF frequency and IF filter that has been selected (60, 200 or 455 kHz). It also depends on the data rate (0.3 – 9.6 kbps) and the FSK frequency separation (0 – 200 kHz). Frequency *separation* is twice

the frequency *deviation* (for example, 20 kHz separation is +/-10 kHz deviation).

Some typical figures are shown in Table 12.

Data rate	IF frequency	Separation	CC400
1.2 kbps	60 kHz	20 kHz	-110 dBm
	200 kHz	40 kHz	-103 dBm
	455 kHz ext	12 kHz	-108 dBm
2.4 kbps	60 kHz	30 kHz	-110 dBm
	200 kHz	40 kHz	-103 dBm
	455 kHz ext	20 kHz	-103 dBm
4.8 kbps	200 kHz	40 kHz	-101 dBm
	455 kHz ext	20 kHz	-99 dBm
9.6 kbps	200 kHz	40 kHz	-97 dBm

Table 12: Sensitivity for different IF frequency, data rates and separation.

In a narrow band system with very low frequency separation (less than 10 kHz) the sensitivity will drop. To insure proper operation the separation should always be larger than 5 kHz (+/- 2.5 kHz deviation). For even smaller separation, or to improve

the sensitivity, an external narrow band demodulator should be used. See Application Note AN005 “Selecting system parameters and system configurations using CC400 / CC900” for more information on narrow band systems.

18. Output power

The output power is controlled through several parameters in the configuration

registers. Table 13 shows recommended settings for the different output powers.

Output power	Class	Register		
		E9:8	F1:0	C8,A7:6,D12:11
-5	A	00	00	01011
-4	AB	01	00	00100
-3	AB	01	01	00101
-2	AB	01	01	00110
-1	AB	01	01	00111
0	B	10	10	00011
1	B	10	10	00100
2	B	10	10	00101
3	B	10	10	00110
4	B	10	10	00111
5	B	10	10	01000
6	B	10	10	01001
7	B	10	10	01010
8	C	11	11	01001
9	C	11	11	01010
10	C	11	11	01100
11	C	11	11	01111
12	C	11	11	10001
13	C	11	11	10101
14	C	11	11	11011

Table 13: Output power settings.

19. Input / Output Matching

Four passive external components combined with the internal T/R switch circuitry ensures match in both RX and TX mode. The matching network for 433.92 MHz is shown in Figure 9. The component values may have to be optimised to

include layout parasitics. Matching components for other frequencies can be found using the configuration software. See also Application Note AN013 "Matching CC400 CC900" for more details.

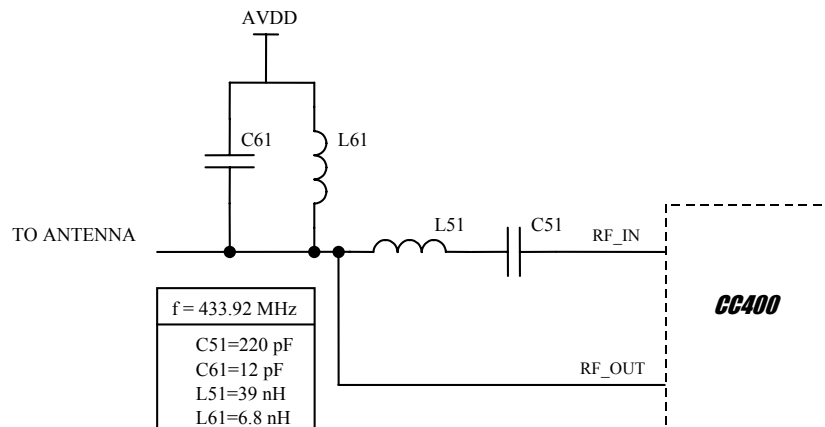

Figure 9: Input/output matching network.

20. Optional LC Filter

An optional LC filter may be added between the antenna and the matching network in certain applications. The filter will reduce the emission of harmonics and increase the receiver selectivity.

The filter for use at 433.92 MHz is shown in Figure 10. The component values may have to be optimised to include layout parasitics. The filter is designed for 50Ω terminations.

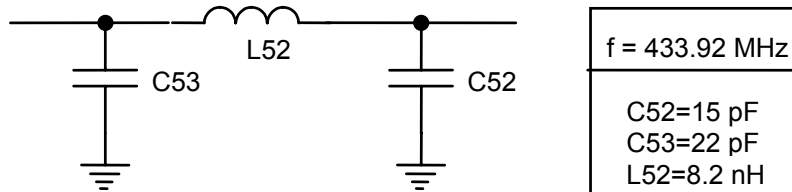

Figure 10: LC filter.

21. Crystal oscillator

An external clock signal or the internal crystal oscillator can be used as main frequency reference. An external clock signal should be connected to XOSC_Q1, while XOSC_Q2 should be left open. The crystal frequency must be in the range 4 - 13 MHz.

The parasitic capacitance is constituted by the pins input capacitance and PCB stray capacitance. Typically the total parasitic capacitance is 4.5 pF. A trimming capacitor may be placed across C151 for initial tuning if necessary.

Using the internal crystal oscillator, the crystal must be connected between XOSC_Q1 and XOSC_Q2. The oscillator is designed for parallel mode operation of the crystal. In addition loading capacitors (C151 and C161) for the crystal are required. The loading capacitor values depend on the total load capacitance, C_L , specified for the crystal. The total load capacitance seen between the crystal terminals should equal C_L for the crystal to oscillate at the specified frequency.

The crystal oscillator circuit is shown in Figure 11. Typical component values for different values of C_L are given in Table 14.

The initial tolerance, temperature drift, ageing and load pulling should be carefully specified in order to meet the required frequency accuracy in a certain application. By specifying the *total* expected frequency accuracy in SmartRF Studio together with data rate and frequency separation, the software will calculate the total bandwidth and compare to the available IF bandwidth. The software will report any contradictions and a more accurate crystal will be recommended if required.

$$C_L = \frac{1}{\frac{1}{C_{151}} + \frac{1}{C_{161}}} + C_{parasitic}$$

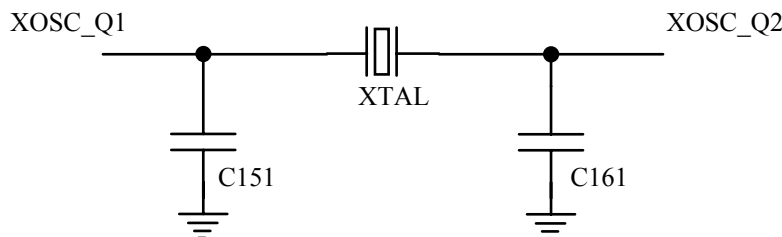

Figure 11: Crystal oscillator circuit.

Item	C _L = 12 pF	C _L = 16 pF	C _L = 22 pF
C151	15 pF	22 pF	33 pF
C161	15 pF	22 pF	33 pF

Table 14: Crystal oscillator component values.

22. Loop filter

The loop filter is a lead-lag type of filter. The calculations for the loop filter components are done in the SmartRF Studio software.

See Application Note AN012 “VCO fine tuning for CC400 and CC900” for more

detailed information. A spreadsheet, CC400_CC900_Loop_Filter_1_0.xls, is available from Chipcon that will calculate the loop filter components for a desired bandwidth with different constants than the default values in SmartRF Studio.

23. Blocking

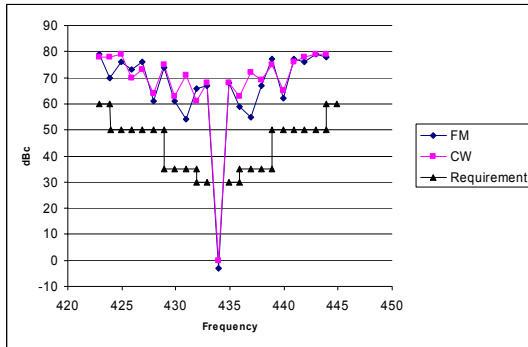

IF =60 kHz, Separation = 20 kHz. Data rate = 1.2 kbps. Interfering signal is CW (no modulation) or FM modulation.

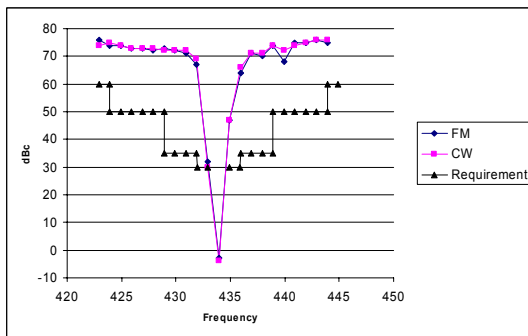

IF =200 kHz, Separation = 40 kHz. Data rate = 1.2 kbps. Interfering signal is CW (no modulation) or FM modulation.

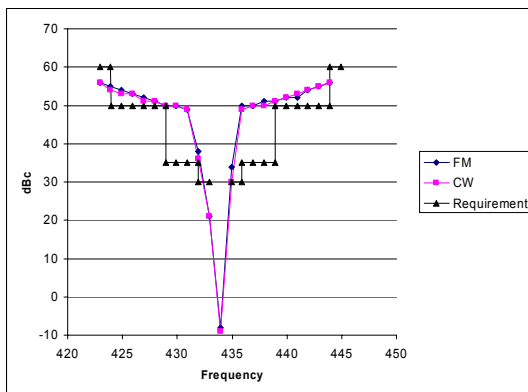

IF =455 kHz external, Separation = 12 kHz. Data rate = 1.2 kbps. Interfering signal is CW (no modulation) or FM modulation.

24. PLL Lock Indicator

The **CC400** PLL lock indicator is available on the LOCK pin. The PLL lock signal is not 100% conclusive. That is, if the LOCK signal indicates lock (i.e. a high signal on the LOCK pin) the PLL has locked to the

desired frequency. However, situations might arise where the lock signal does not indicate lock (i.e. a low signal on the LOCK pin) when in fact the PLL has locked to the desired frequency.

25. Antenna Considerations

The **CC400** can be used together with various types of antennas. The most common antennas for short-range communication are monopole, helical and loop antennas.

Monopole antennas are resonant antennas with a length corresponding to one quarter of the electrical wavelength ($\lambda/4$). They are very easy to design and can be implemented simply as a “piece of wire” or integrated into the PCB.

Non-resonant monopole antennas shorter than $\lambda/4$ can also be used, but at the expense of range. In size and cost critical applications such an antenna may very well be integrated into the PCB.

Helical antennas can be thought of as a combination of a monopole and a loop antenna. They are a good compromise in size critical applications. But helical antennas tend to be more difficult to optimise than the simple monopole.

Loop antennas are easy to integrate into the PCB, but are less effective due to difficult impedance matching because of their very low radiation resistance.

For low power applications the $\lambda/4$ -monopole antenna is recommended giving the best range and because of its simplicity.

The length of the $\lambda/4$ -monopole antenna is given by:

$$L = 7125 / f$$

where f is in MHz, giving the length in cm. An antenna for 433.92 MHz should be 16.4 cm.

The antenna should be connected as close as possible to the IC. If the antenna is located away from the input pin the antenna should be matched to the feeding transmission line. See Application Note AN003 “Antennas” for more details.

26. System Considerations and Guidelines

26.1. Low-cost systems

In systems where low cost is of great importance the 200 kHz IF should be used. The oscillator crystal can then be a low cost crystal with 50 ppm frequency tolerance.

26.2. Battery operated systems

In low power applications the power down mode should be used when not being active. Depending on the start-up time requirement, the oscillator core can be powered during power down. Precharging of the demodulator may also be used to reduce the receiver turn-on time, see description p.21.

26.3. Narrow band systems

CC400 is also suitable for use in narrow band systems. However, it is then required to use a crystal with low temperature drift and ageing. A trimmer capacitor in the crystal oscillator circuit (in parallel with C151) may also be necessary to set the initial frequency.

It is also possible to include an external IF-filter at 455 kHz. This should be a ceramic filter with 1.5 k Ω input/output impedance connected between IF_OUT and IF_IN. Typical bandwidth is 30 kHz. Due to the high Q of such a filter, a better selectivity can be achieved. See Application Note AN005 "Selecting system parameters and system configurations using CC400 / CC900" for more details.

26.4. High reliability systems

Using a SAW filter as a preselector will improve the communication reliability in harsh environments by reducing the probability of blocking.

26.5. Spread spectrum frequency hopping systems

Due to the very fast frequency shift properties of the PLL, the **CC400** may very well be used in frequency hopping systems.

27. Demodulator Precharging For Reduced Turn-on Time

The demodulator data slicer has an internal AC coupling giving a time constant of approximately 30 periods of the bit rate period. This means that before proper demodulation can take place, a minimum of 30 start-bits has to be received.

In critical applications where the start-up time should be decreased in order to

reduce the power consumption, this time constant can be reduced to 5 periods using the optional precharging possibility. The precharging is done during data reception by setting the precharging bit in the configuration register active with duration of at least 5 bit periods.

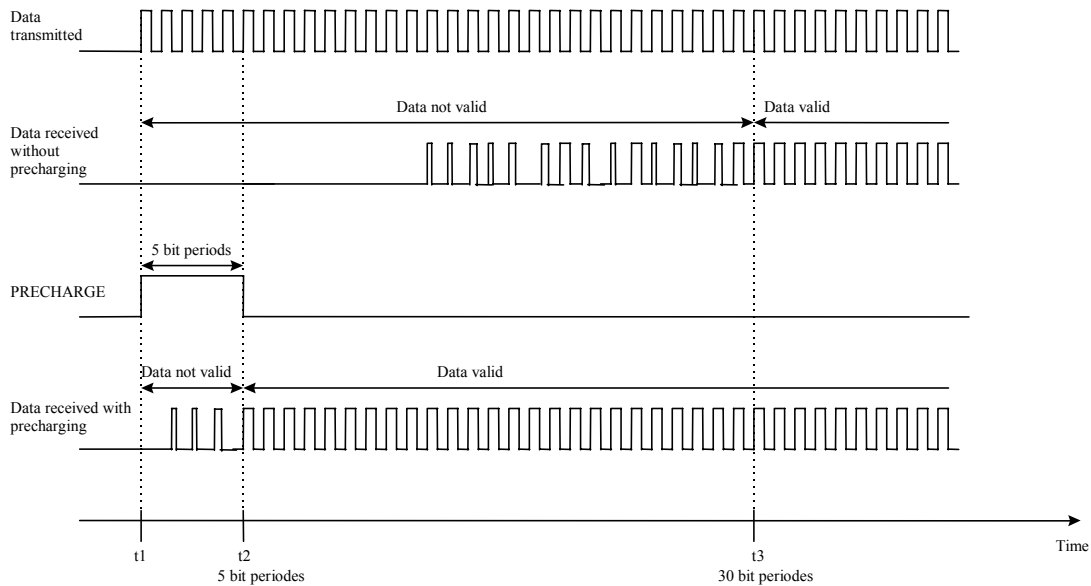

Figure 12: Demodulation using precharging.

In the example shown in Figure 12, data is transmitted continuously from the transmitter (all 1's). At $t=t_1$ the receiver is turned on, and then the precharging is

kept on for about 5 bit periods. At $t=t_2$ the received data is valid and precharging is turned off. When not using precharging, data is not valid until 30 bit periods, at $t=t_3$.

28. PCB Layout Recommendations

A two layer PCB is highly recommended. The bottom layer of the PCB should be the “ground-layer”.

The top layer should be used for signal routing, and the open areas should be filled with metallization connected to ground using several vias.

The ground pins should be connected to ground as close as possible to the package pin. The decoupling capacitors should also be placed as close as possible to the supply pins and connected to the ground plane by separate vias.

The external components should be as small as possible and surface mount devices should be used.

Precaution should be used when placing the microcontroller in order to avoid interference with the RF circuitry.

In most applications the ground plane can be one common plane, but in certain applications where the ground plane for the digital circuitry is expected to be noisy, the ground plane may be split in an analogue and a digital part. All AGND pins and AVDD decoupling capacitors should be connected to the analogue ground plane. All DGND pins and DVDD decoupling capacitors should be connected to the digital ground. The connection between the two ground planes should be implemented as a star connection with the power supply ground.

The **CC400DB** reference design is available from Chipcon’s web site, and should be used as a guideline for PCB layout.

29. Configuration registers

The configuration of **CC400** is done by programming the 8 13-bit configuration registers. The configuration data based on selected system parameters are most easily found by using the SmartRF Studio software. A complete description of the registers is given in the following tables.

REGISTER OVERVIEW

Address	Register Name	Description
000	A	Main control register
001	B	General control register
010	C	General control register
011	D	General control register
100	E	General control register
101	F	General control register
110	G	General control register
111	H	General control register

Register A

REGISTER	NAME	Default value	Active	Description
A[12]	PD	-	H	Power Down 0 = Chip Enable 1 = Chip Disable (only reference oscillator core on)
A[11]	RXTX	-		Receive/Transmit-mode control 0 = Receive mode 1 = Transmit mode
A[10:8]	S[2:0]	000		Synthesiser test modes (apply when TDEM2=0) <u>Modus (000):</u> Normal operation: Rx/Tx. <u>Modus (001):</u> Divided signal from VCO at PD input monitored at LOCK pin. Modulation (control of A-counter) is disabled. <u>Modus (010):</u> Divided signal from VCO at PD input monitored at LOCK pin. Modulation (control of A-counter) is enabled. <u>Modus (011):</u> Output from reference divider monitored at LOCK pin. <u>Modus (100):</u> Signal at TX_DATA pin used as modulation control overriding the signal from the dual-modulus divider. Output monitored at LOCK pin. <u>Modus (101):</u> Output from prescaler monitored at LOCK pin. Modulation (A-divider control) disabled. <u>Modus (110):</u> Output from prescaler monitored at LOCK pin. Modulation (A-divider control) disabled. <u>Modus (111):</u> Shift register data output monitored at LOCK pin.
A[7:6]	PA[3:2]	-		PA gain programming. Part of PA4:PA0. (PA1:PA0 is in frame D, PA4 is in frame C)
A[5:4]	LNA[1:0]	10		LNA bias current and gain 00 = 0.94mA= I_0 01 = 1.5* I_0 =1.40mA 10 = 2* I_0 =1.87mA (nominal setting) 11 = 3* I_0 =2.81mA
A[3:2]	MIX[1:0]	10		MIXER bias current and gain 00 = 0.36mA 01 = 0.54mA 10 = 0.72mA (nominal setting) 11 = 1.08mA
A[1:0]	LO[1:0]	10		LO drive (peak-differential = peak-peak single-ended) 00 = 144mV 01 = 288mV 10 = 432mV (nominal setting) 11 = 720mV

Register B

REGISTER	NAME	Default value	Active	Description
B[12:11]	AB[1:0]	00		Antibacklash pulse width 00 = 0ns (nominal setting) 01 = 2.7ns 10 = 4.8ns 11 = 10.9ns Tolerance (+200% / - 70%)
B[10:7]	A[3:0]	-		A-counter
B[6:0]	M[6:0]	-		M-counter

Register C

REGISTER	NAME	Default value	Active	Description
C[12]	RESSYN	0		Synthesiser reset 0 = Normal operation 1 = Reset synthesiser
C[11:9]	V[3:1]	-		VCO gain programming. LSB-bit VO = "0". 000= maximum gain 111=minimum gain Reduce gain to reduce LO spurious emission
C[8]	PA[4]	-		PA gain programming. Part of PA4:PA0
C[7]	FSIG	-		Charge pump polarity 0 = Add charge when VREF leads FVCO (Normal) 1 = Sink charge when VREF leads FVCO
C[6:5]	CHP[1:0]	10		Charge pump current: 00 = 10µA 01 = 20µA 10 = 40µA (nominal setting) 11 = 80µA
C[4]	PDX	-	H	Reference oscillator power down 0 = Power on even during main power down 1 = Power down (during main power down)
C[3:0]	R[3:0]	-		R-divider

Register D

REGISTER	NAME	Default value	Active	Description
D[12:11]	PA[1:0]	-		PA gain programming. Part PA4
D[10:0]	K[10:0]	-		K-counter K10 er sign bit (0=positive, 1 negative). Negative K must be 2's complement

Register E

REGISTER	NAME	Default value	Active	Description
E[12]	LW	0		PLL <u>Lock-Window</u> tolerance 0 = 21ns (Normal setting) 1 = 44ns
E[11]	LM	-		Lock mode (Lock is reset when PLL is reprogrammed). 0 = Single shot 1 = Continuous
E[10]	LH	-		Lock detection enable 0 = Lock detection enabled 1 = Lock detection disabled (LOCK=1)

REGISTER	NAME	Default value	Active	Description
E[9:8]	PACL[1:0]	-		PA "class" 00 = Class A 01 = Class AB 10 = Class B 11 = Class C
E[7:0]	D[7:0]	-		D-counter Frequency seperation programming

Register F

REGISTER	NAME	Default value	Active	Description
F[12:11]	DCLK[1:0]	-		Demodulator shift register clock selection 00 = External clock (25MHz) at TX_DATA. 01 = 12.8 MHz from crystal oscillator 10 = 25 MHz from prescaler 11 = 12.5MHz from prescaler
F[10:9]	DEMIF[1:0]	-		Demodulator phase shift / IF control 00 = 60kHz IF 01 = 200kHz IF 10 = 455kHz IF 11 = Test modes using DCLK1:DCLK0
F[8:6]	TDEM[2:0]	000		Test modes for demodulator. Output is monitored at LOCK pin. See also S2:S0 in frame A. TDEM2=0: As described for S2:S0 in frame A TDEM2=1 : Demodulator test modes. <u>Modus (000):</u> Normal setting. <u>Modus (0XX):</u> Test as for S2:S0 in frame A monitored at LOCK pin. <u>Modus (100):</u> Demodulator input monitored at LOCK pin. <u>Modus (101):</u> Phase shifted signal monitored at LOCK pin. <u>Modus (110):</u> Phase detector output monitored at LOCK pin. <u>Modus (111):</u> Demodulator output at LOCK pin. IF input at TX_DATA.
F[5:3]	PAIMP[2:0]	-		PA capacitor array. Array is active in RX or TX depending on INVARRAY. 000 = 0pF 001 = 1.25pF 010 = 2.5pF 011 = 3.75pF 100 = 5pF 101 = 6.25pF 110 = 7.5pF 111 = 8.75pF
F[2]	INVARRAY	-		PA capacitor array activation. 0 = Capacitor array active in RX mode 1 = Capacitor array active in TX mode
F[1:0]	PAEC[1:0]	-		PA buffer amplifier drive level 00 = 3mA 01 = 5mA 10 = 8mA 11 = 11mA

Register G

REGISTER	NAME	Default value	Active	Description
G[12:11]	IFQ[1:0]	-		IF filter Q-value 00 = low 01 = 10 = 11 = high
G[10:9]	IFG[1:0]	-		IF amplifier gain 00 = lowest 01 = 10 = 11 = highest
G[8:6]	LPIF[2:0]	-		IF filter low-pass cut-off 000 = lowest 001 = 010 = 011 = 100 = 101 = 110 = 111 = highest
G[5:3]	HPIF[2:0]	-		IF filter high-pass cut-off 000 = lowest 001 = 010 = 011 = 100 = 101 = 110 = 111 = highest
G[2:0]	MIF[2:0]	-		IF mode control, external filter selection 000 = Differential input, 1. Ceramic filter 001 = Single-ended input 1. ceramic filter 010 = Differential input, 1. and 2. ceramic filter (NA) 011 = Single-ended input, 1. and 2. ceramic filter (NA) 100 = Differential input, no ceramic filters filters 101 = Single-ended input, no ceramic filters 110 = NA 111 = Single-ended input, 1. Ceramic filter

Register H

REGISTER	NAME	Default value	Active	Description
H[12:10]	LPDEM[2:0]	-		Demodulator data filter cut-off (low pass) 000 = 5.8kHz 001 = 9.3kHz 010 = 13.9kHz 011 = 19.9kHz 100 = 28.0kHz 101 = 36.2kHz 110 = 64.8kHz 111 = 134.2kHz
H[9]	FASTACIDF	0		Demodulator datafilter AC coupling time constant (Precharge) 0 = Normal/high time constant 1 = Low time constant (precharge)

REGISTER	NAME	Default value	Active	Description
H[8]	TOPFILT	-		Demodulator data filter topology AC coupling by-pass 0 = Two AC couplings 1 = One AC coupling
H[7:6]	HYSTDEM[1:0]	-		Demodulator data slicer comparator hysteresis 00 = 0mV 01 = 15mV 10 = 40mV 11 = 100mV
H[5:4]	HPDEM[1:0]	-		Demodulator data filter high-pass cut-off 00 = 30Hz 01 = 60Hz 10 = 120Hz 11 = 240Hz
H[3]	EXTACDF	0		Demodulator external AC-coupling 0 = Internal 1 = Eksternal (NA)
H[2]	IFSIGEXT	0		IF test mode IF signal input at TX_DATA pin Use LOCK pin as demodulator output 0 = Normal 1 = Test mode
H[1]	QUADSWING	-		Quadrature detector output level 0 = VDD (normal setting) 1 = Reduced amplitude (VDD/2)
H[0]	IFDOFF	0		IF and demodulator Power Down (overrided by global power down). 0 = IF and demodulator active (if PD=0 and RxTx=0). Normal setting. 1 = IF and demodulator power down

30. Package Description (SSOP-28)

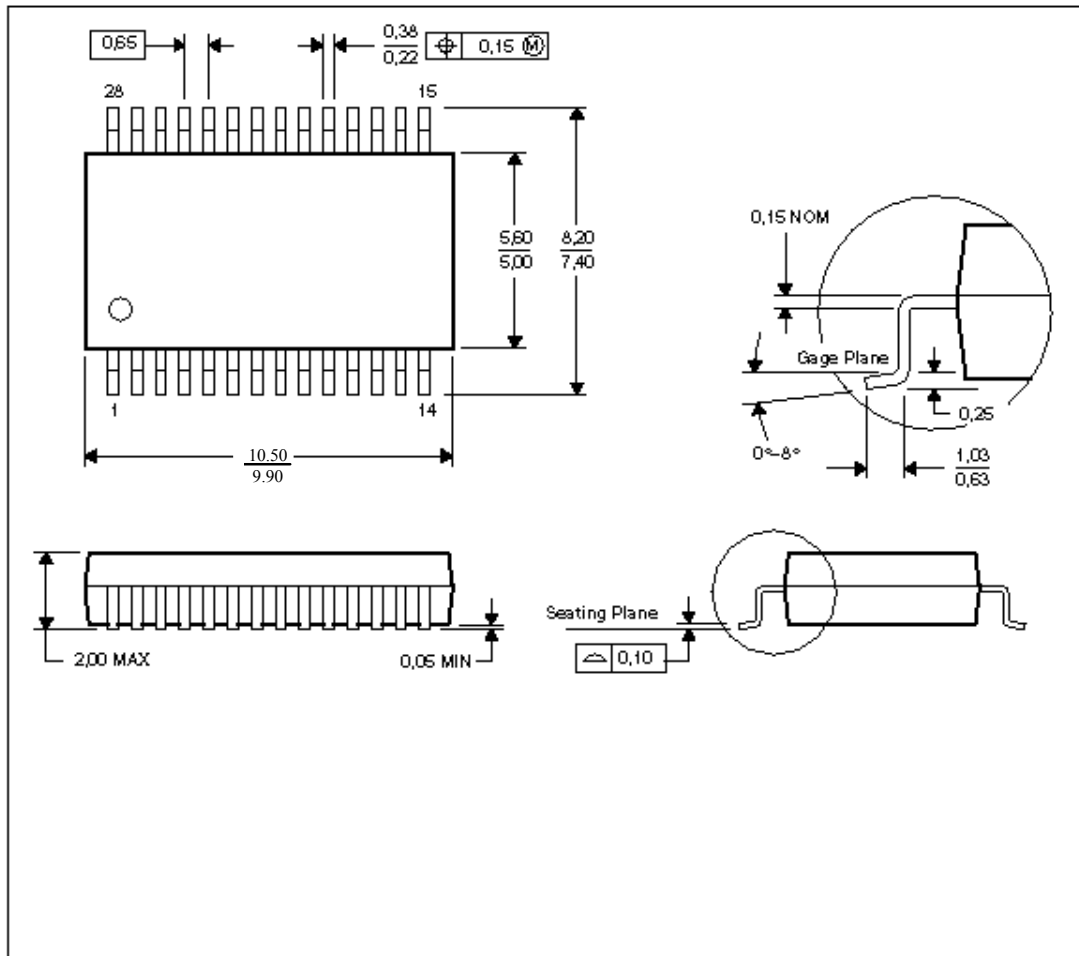

Figure 13: Package Dimensions Drawing

NOTES:

- A. All linear dimensions are in millimeters.
- B. This drawing is subject to change without notice.
- C. Body dimensions do not include mold flash or protrusion not to exceed 0.1mm.
- D. Falls within JEDEC MO-150.

31. Soldering Information

The recommended reflow soldering profiles for SnPb eutectic and Pb-free soldering for Small Body SMD packages are according to IPC/JEDEC J-STD-020C.

32. Plastic Tube Specification

SSOP 5.3mm (.208") antistatic tube.

Tube Specification				
Package	Tube Width	Tube Height	Tube Length	Units per Tube
SSOP 28	10.6	4 mm	20"	47

Table 15: Plastic Tube Specification

33. Carrier Tape and Reel Specification

Carrier tape and reel is in accordance with EIA Specification 481.

Tape and Reel Specification					
Package	Tape Width	Component Pitch	Hole Pitch	Reel Diameter	Units per Reel
SSOP 28	24 mm	12 mm	4 mm	13"	2000

Table 16: Carrier Tape and Reel Specification

34. Ordering Information

Ordering part number	Description
CC400-STB2	CC400 8inch wafer, SSOP28 package, standard leaded assembly, tubes with 47 pcs per tube
CC400-STR2	CC400 8inch wafer, SSOP28 package, standard leaded assembly, T&R with 2000 pcs per reel
CC400-RTB2	CC400 8inch wafer, SSOP28 package, RoHS compliant Pb-free assembly, tubes with 47 pcs per tube
CC400-RTR2	CC400 8inch wafer, SSOP28 package, RoHS compliant Pb-free assembly, T&R with 2000 pcs per reel
CC400DK	CC400 Development Kit
CC400SK	CC400 Sample Kit (5 pcs.)

Table 17: Ordering Information

35. General Information

35.1. Document History

Revision	Date	Description/Changes
3.2	2005-05-25	Updated the following performance figures: <ul style="list-style-type: none"> • Power Down current • Receive current • Transmit current • Sensitivity • LO leakage New varactor component (PB-free) added Soldering information updated New ordering information added Document history added from revision 3.2 of the data sheet Product Status Definitions added Disclaimer updated Address Information updated

Table 18: Document History

35.2. Product Status Definitions

Data Sheet Identification	Product Status	Definition
Advance Information	Planned or Under Development	This data sheet contains the design specifications for product development. Specifications may change in any manner without notice.
Preliminary	Engineering Samples and First Production	This data sheet contains preliminary data, and supplementary data will be published at a later date. Chipcon reserves the right to make changes at any time without notice in order to improve design and supply the best possible product.
No Identification Noted	Full Production	This data sheet contains the final specifications. Chipcon reserves the right to make changes at any time without notice in order to improve design and supply the best possible product.
Obsolete	Not In Production	This data sheet contains specifications on a product that has been discontinued by Chipcon. The data sheet is printed for reference information only.

Table 19: Product Status Definitions

35.3. Disclaimer

Chipcon AS believes the information contained herein is correct and accurate at the time of this printing. However, Chipcon AS reserves the right to make changes to this product without notice. Chipcon AS does not assume any responsibility for the use of the described product.; neither does it convey any license under its patent rights, or the rights of others. The latest updates are available at the Chipcon website or by contacting Chipcon directly.

As far as possible, major changes of product specifications and functionality, will be stated in product specific Errata Notes published at the Chipcon website. Customers are encouraged to sign up to the Developers Newsletter for the most recent updates on products and support tools.

When a product is discontinued this will be done according to Chipcon's procedure for obsolete products as described in Chipcon's Quality Manual. This includes informing about last-time-buy options. The Quality Manual can be downloaded from Chipcon's website.

Compliance with regulations is dependent on complete system performance. It is the customer's responsibility to ensure that the system complies with regulations.

35.4. Trademarks

SmartRF[®] is a registered trademark of Chipcon AS. *SmartRF*[®] is Chipcon's RF technology platform with RF library cells, modules and design expertise. Based on *SmartRF*[®] technology Chipcon develops standard component RF circuits as well as full custom ASICs based on customer requirements and this technology.

All other trademarks, registered trademarks and product names are the sole property of their respective owners.

35.5. Life Support Policy

This Chipcon product is not designed for use in life support appliances, devices, or other systems where malfunction can reasonably be expected to result in significant personal injury to the user, or as a critical component in any life support device or system whose failure to perform can be reasonably expected to cause the failure of the life support device or system, or to affect its safety or effectiveness. Chipcon AS customers using or selling these products for use in such applications do so at their own risk and agree to fully indemnify Chipcon AS for any damages resulting from any improper use or sale.