

## LED Driver with Average-Current Mode Constant-Current Control

### Features

- Fast Average Current Control
- Programmable Constant Off-time Switching
- Linear Dimming Input
- PWM Dimming Input
- Output Short-circuit Protection with Skip Mode
- -40°C to +125°C Ambient Operating Temperature
- Pin-compatible with HV9910B

### Applications

- DC/DC or AC/DC LED Driver Applications
- LED Backlight Driver for LCD Displays
- General Purpose Constant-current Source
- LED Signage and Displays
- Architectural and Decorative LED Lighting
- LED Street Lighting

### General Description

The HV9961 is an Average-Current mode constant-current control LED driver IC operating in a constant Off-time mode. Unlike the HV9910B, this control IC does not produce a peak-to-average error. This greatly improves accuracy as well as the line and load regulations of the LED current without any need for loop compensation or high-side current sensing. Its output LED current accuracy is  $\pm 3\%$ .

The IC is equipped with a current limit comparator for Hiccup mode output short-circuit protection.

The HV9961 can be powered from an 8V–450V supply. It has a PWM dimming input that accepts an external control TTL-compatible signal. In addition, the output current can be programmed by an internal 275 mV reference or controlled externally through a 0V–1.5V linear dimming input.

The HV9961 is pin-to-pin compatible with HV9910B, and it can be used as a drop-in replacement for many applications to improve LED current accuracy and regulation.

### Package Types

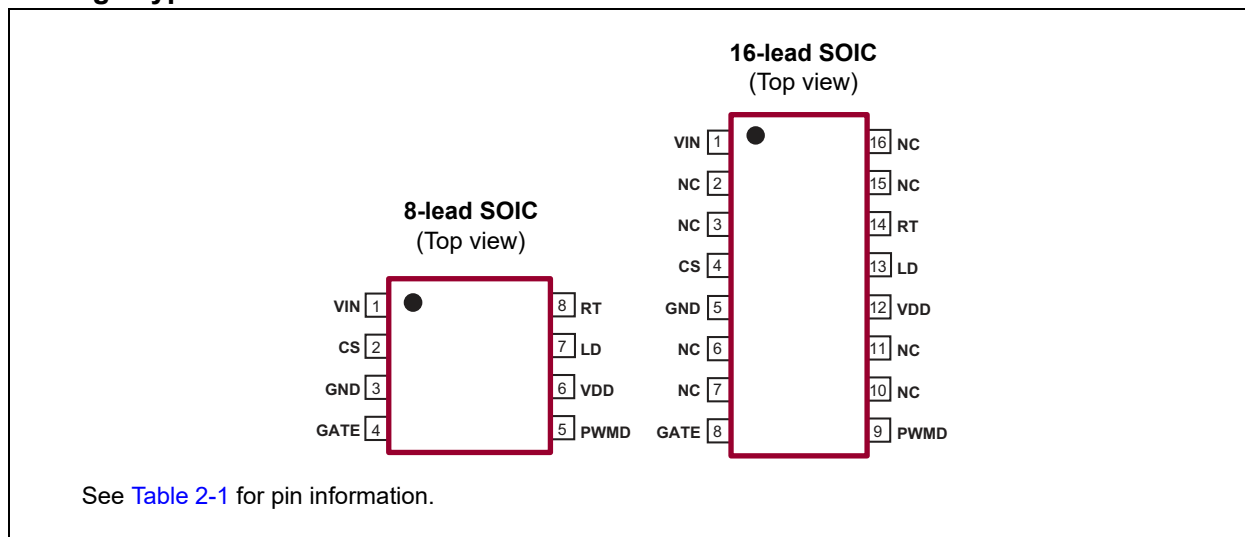

# HV9961

## Functional Block Diagram

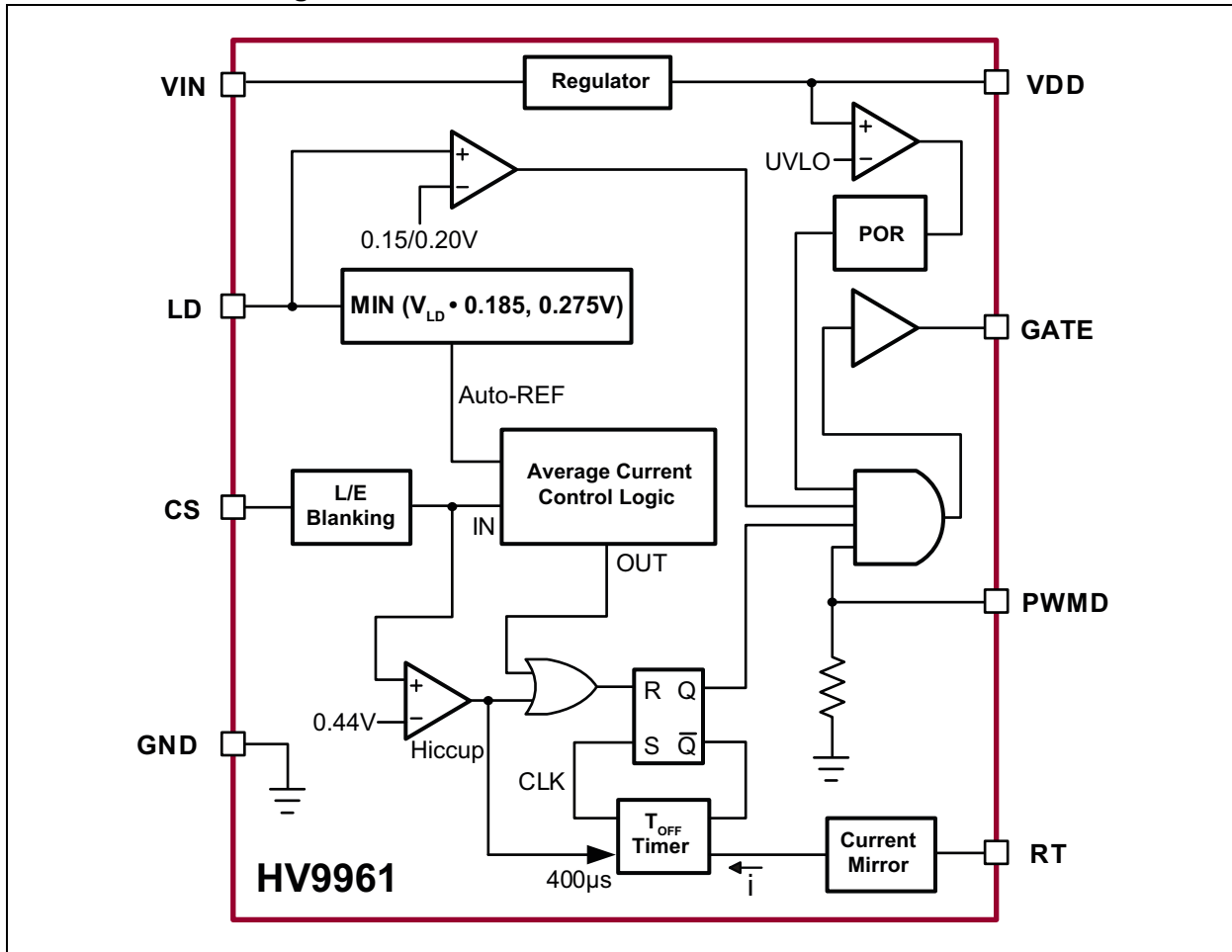

## Typical Application Circuit

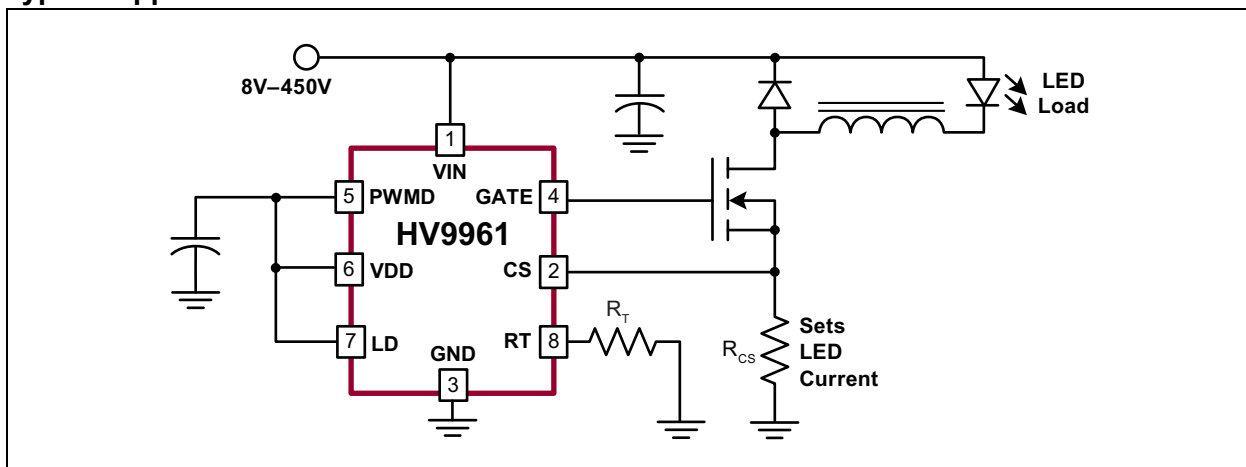

## 1.0 ELECTRICAL CHARACTERISTICS

### Absolute Maximum Ratings†

$V_{IN}$ to GND .....	-0.5V to +470V
$V_{DD}$ to GND .....	+12V
CS, LD, PWMD, Gate, RT to GND.....	-0.3V to $V_{DD}+0.3V$
Continuous Power Dissipation ( $T_A = +25^\circ\text{C}$ ):	
8-lead SOIC .....	650 mW
16-lead SOIC .....	1000 mW

† **Notice:** Stresses above those listed under “Absolute Maximum Ratings” may cause permanent damage to the device. This is a stress rating only, and functional operation of the device at those or any other conditions above those indicated in the operational sections of this specification is not intended. Exposure to maximum rating conditions for extended periods may affect device reliability.

### ELECTRICAL CHARACTERISTICS

**Electrical Specifications:**  $T_A = 25^\circ\text{C}$ ,  $V_{IN} = 12V$ ,  $V_{LD} = V_{DD}$ , and  $V_{PWMD} = V_{DD}$  unless otherwise specified.

Parameter	Sym.	Min.	Typ.	Max.	Unit	Conditions
<b>INPUT</b>						
Input DC Supply Voltage Range	$V_{INDC}$	8	—	450	V	DC input voltage ( <a href="#">Note 1</a> and <a href="#">Note 2</a> )
Shutdown Mode Supply Current	$I_{INSD}$	—	0.5	1	mA	Pin PWMD connected to GND ( <a href="#">Note 2</a> )
<b>INTERNAL REGULATOR</b>						
Internally Regulated Voltage	$V_{DD}$	7.25	7.5	7.75	V	$V_{IN} = 8V$ , $I_{DD(EXT)} = 0\text{ mA}$ , 500 pF at gate, $R_T = 226\text{ k}\Omega$
Line Regulation of $V_{DD}$	$\Delta V_{DD, \text{line}}$	0	—	1	V	$V_{IN} = 8V-450V$ , $I_{DD(EXT)} = 0\text{ mA}$ , 500 pF at gate, $R_T = 226\text{ k}\Omega$
Load Regulation of $V_{DD}$	$\Delta V_{DD, \text{load}}$	0	—	100	mV	$I_{DD(EXT)} = 0\text{ mA}-1\text{ mA}$ , 500 pF at gate, $R_T = 226\text{ k}\Omega$
$V_{DD}$ Undervoltage Lockout Upper Threshold	$V_{UVLO}$	6.45	6.7	6.95	V	$V_{IN}$ rising ( <a href="#">Note 2</a> )
$V_{DD}$ Undervoltage Lockout Hysteresis	$\Delta V_{UVLO}$	—	500	—	mV	$V_{IN}$ falling
Maximum Input Current (Limited by UVLO)	$I_{IN, \text{MAX}}$	3.5	—	—	mA	$V_{IN} = 8V$ , $T_A = 25^\circ\text{C}$ ( <a href="#">Note 3</a> )
		1.5	—	—		$V_{IN} = 8V$ , $T_A = 125^\circ\text{C}$ ( <a href="#">Note 3</a> )
<b>PWM DIMMING</b>						
PWMD Input Low Voltage	$V_{PWMD(LO)}$	—	—	0.8	V	$V_{IN} = 8V-450V$ ( <a href="#">Note 2</a> )
PWMD Input High Voltage	$V_{PWMD(HI)}$	2.2	—	—	V	$V_{IN} = 8V-450V$ ( <a href="#">Note 2</a> )
PWMD Pull-down Resistance	$R_{PWMD}$	50	100	150	k $\Omega$	$V_{PWMD} = 5V$
<b>AVERAGE-CURRENT SENSE LOGIC</b>						
Current Sense Reference Voltage	$V_{CST}$	264	275	286	mV	$V_{LD} = 1.5V$
LD-to-CS Voltage Ratio	$A_{V(LD)}$	0.178	0.185	0.188	—	$V_{LD} = 1.2V$
LD-to-CS Voltage Offset	$A_V \times V_{LD(OFFSET)}$	-15	—	15	mV	Offset = $V_{CS} - A_{V(LD)} \times V_{LD}$ , $V_{LD} = 1.2V$
CS Threshold Temperature Regulation	$\Delta V_{CST(TEMP)}$	—	—	5	mV	( <a href="#">Note 2</a> )

**Note 1:** Also limited by package power dissipation limit, whichever is lower

**2:** Denotes specifications which apply over the full operating ambient temperature range of  $-40^\circ\text{C} < T_A < +125^\circ\text{C}$

**3:** Specification is obtained by characterization and is not 100% tested.

# HV9961

## ELECTRICAL CHARACTERISTICS (CONTINUED)

Electrical Specifications: $T_A = 25^\circ\text{C}$ , $V_{IN} = 12\text{V}$ , $V_{LD} = V_{DD}$ , and $V_{PWMD} = V_{DD}$ unless otherwise specified.						
Parameter	Sym.	Min.	Typ.	Max.	Unit	Conditions
LD Input Shutdown Threshold Voltage	$V_{LD(OFF)}$	—	150	—	mV	$V_{LD}$ falling
LD Input Enable Threshold Voltage	$V_{LD(EN)}$	—	200	—	mV	$V_{LD}$ rising
Current Sense Blanking Interval	$T_{BLANK}$	150	—	340	ns	(Note 2)
Minimum On-time	$T_{ON(MIN)}$	—	—	1000	ns	$V_{CS} = V_{CST} + 30\text{ mV}$
Maximum Steady-state Duty Cycle	$D_{MAX}$	75	—	—	%	Reduction in output LED current may occur beyond this duty cycle
<b>SHORT-CIRCUIT PROTECTION</b>						
Hiccup Threshold Voltage	$V_{CSH}$	410	440	470	mV	
Current Limit Delay CS-to-Gate	$T_{DELAY}$	—	—	185	ns	$V_{CS} = V_{CSH} + 30\text{ mV}$
Short-circuit Hiccup Time	$T_{HICCUP}$	350	400	550	$\mu\text{s}$	
Minimum On-time (Short-circuit)	$T_{ON(MIN),SC}$	—	—	430	ns	$V_{CS} = V_{DD}$
<b>T<sub>OFF</sub> TIMER</b>						
Off-time	$T_{OFF}$	32	40	48	$\mu\text{s}$	$R_T = 1\text{ M}\Omega$
		8	10	12		$R_T = 226\text{ k}\Omega$
<b>GATE DRIVER</b>						
Gate Sourcing Current	$I_{SOURCE}$	0.165	—	—	A	$V_{GATE} = 0\text{V}$ , $V_{DD} = 7.5\text{V}$
Gate Sinking Current	$I_{SINK}$	0.165	—	—	A	$V_{GATE} = V_{DD}$ , $V_{DD} = 7.5\text{V}$
Gate Output Rise Time	$t_r$	—	30	50	ns	$C_{GATE} = 500\text{ pF}$ , $V_{DD} = 7.5\text{V}$
Gate Output Fall Time	$t_f$	—	30	50	ns	$C_{GATE} = 500\text{ pF}$ , $V_{DD} = 7.5\text{V}$

**Note 1:** Also limited by package power dissipation limit, whichever is lower

**2:** Denotes specifications which apply over the full operating ambient temperature range of  $-40^\circ\text{C} < T_A < +125^\circ\text{C}$

**3:** Specification is obtained by characterization and is not 100% tested.

## TEMPERATURE SPECIFICATIONS

Parameter	Sym.	Min.	Typ.	Max.	Unit	Conditions
<b>TEMPERATURE RANGES</b>						
Operating Ambient Temperature	$T_A$	-40	—	+125	$^\circ\text{C}$	
Junction Temperature	$T_J$	-40	—	+150	$^\circ\text{C}$	
Storage Temperature	$T_S$	-65	—	+150	$^\circ\text{C}$	
<b>PACKAGE THERMAL RESISTANCE</b>						
8-lead SOIC	$\theta_{JA}$	—	101	—	$^\circ\text{C/W}$	
16-lead SOIC	$\theta_{JA}$	—	83	—	$^\circ\text{C/W}$	

## 2.0 PIN DESCRIPTION

The details on the pins of HV9961 are listed on [Table 2-1](#). Refer to [Package Types](#) for the location of pins.

**TABLE 2-1: PIN FUNCTION TABLE**

Pin Number		Pin Name	Description
8-lead SOIC	16-lead SOIC		
1	1	VIN	This pin is the input of an 8V–450V linear regulator.
2	4	CS	This pin is the current sense pin used to sense the FET current with an external sense resistor.
3	5	GND	Ground return for all internal circuitry. This pin must be electrically connected to the ground of the power train.
4	8	Gate	This pin is the output of gate driver for driving an external N-channel power MOSFET.
5	9	PWMD	This is the PWM dimming input of the IC. When this pin is pulled to GND, the gate driver is turned off. When the pin is pulled high, the gate driver operates normally.
6	12	V <sub>DD</sub>	This is the power supply pin for all internal circuits. It must be bypassed with a low ESR capacitor to GND (at least 0.1 μF).
7	13	LD	This pin is the linear dimming input, and it sets the current sense threshold as long as the voltage at this pin is less than 1.5V. If voltage at LD falls below 150 mV, the gate output is disabled. The gate signal recovers at 200 mV at LD.
8	14	RT	A resistor connected between this pin and GND programs the gate off-time.
—	2, 3, 6, 7, 10, 11, 15, 16	NC	No connection.

## 3.0 APPLICATION INFORMATION

### 3.1 General Description

Peak current control (as in HV9910B) is the simplest and the most economical way to regulate a buck converter's output current. However, it suffers accuracy and regulation problems that arise from peak-to-average current error, contributed by the current ripple in the output inductor and the propagation delay in the current sense comparator. The full inductor current signal is unavailable for direct switch current sensing across the sense resistor at the ground path in this low-side switch buck converter when the control switch is at the ground potential because the switch is turned off. While it is very simple to detect the peak current in the switch, controlling the average inductor current is usually implemented by level translating the sense signal from  $+V_{IN}$ . Although this is practical for a relatively low-input voltage,  $V_{IN}$ , this type of average-current control may become excessively complex and expensive in the offline AC or other high-voltage DC applications.

The HV9961 uses a proprietary control scheme that allows fast and accurate control of the average current in the buck inductor by sensing the switch current only. No compensation of the current control loop is required. The output LED current's response to PWM input is similar to that of the HV9910B. The effect of inductor current ripple amplitude on this control scheme is insignificant. Therefore, the LED current is independent of the variation in inductance, switching frequency or output voltage. Constant off-time control of the buck converter is used for stability and improving the LED current regulation over a wide range of input voltages. Unlike HV9910B, the HV9961 does not support Constant Frequency mode.

### 3.2 Off Timer

The timing resistor connected between RT and GND determines the off-time of the gate driver. Wiring this resistor between RT and Gate as with HV9910B is no longer supported. Refer to [Equation 3-1](#) for the computation of the gate output's off-time.

#### EQUATION 3-1:

$$T_{OFF}(\mu s) = \frac{R_T(k\Omega)}{25} + 0.3$$

within the range of  $30\text{ k}\Omega \leq R_T \leq 1\text{ M}\Omega$

### 3.3 Average-Current Control Feedback and Output Short-circuit Protection

The current through the switching Metal-oxide Semiconductor Field-effect Transistor (MOSFET) source is averaged and used to give constant-current feedback. This current is detected with a sense resistor at the CS pin. The feedback operates in a fast Open-loop mode. No compensation is required. Output current is programmed as seen in [Equation 3-2](#).

#### EQUATION 3-2:

$$I_{LED} = \frac{0.275V}{R_{CS}}$$

When the voltage at the LD input  $V_{LD} \geq 1.5V$

If the voltage at the LD input is less than 1.5V, the output current is computed as specified in [Equation 3-3](#).

#### EQUATION 3-3:

$$I_{LED} = \frac{V_{LD} \times 0.185}{R_{CS}}$$

When the voltage at the LD input  $0.2V \leq V_{LD} < 1.5V$

The above equations are only valid for continuous conduction of the output inductor. It is good design practice to choose the inductance of the inductor such that the peak-to-peak inductor current is 30% to 40% of the average DC full-load current. Hence, the recommended inductance can be calculated as shown in [Equation 3-4](#).

#### EQUATION 3-4:

$$L_O = \frac{V_{O(MAX)} \times T_{OFF}}{0.4 \times I_O}$$

The duty-cycle range of the current control feedback is limited to  $D \leq 0.75$ . A reduction in the LED current may occur when the desired LED string voltage  $V_O$  is greater than 75% of the input voltage  $V_{IN}$  of the HV9961 LED driver.

Reducing the targeted output LED string voltage  $V_O$  below  $V_{O(MIN)} = V_{IN} \times D_{MIN}$ , where  $D_{MIN} = 1\ \mu s / (T_{OFF} + 1\ \mu s)$ , may also result in the loss of regulation of the LED current. This condition, however, causes an increase in the LED current and can potentially trip the short-circuit protection comparator.

The typical output characteristic of the HV9961 LED driver is shown in [Figure 3-1](#). The corresponding HV9910B characteristic is given for the comparison.

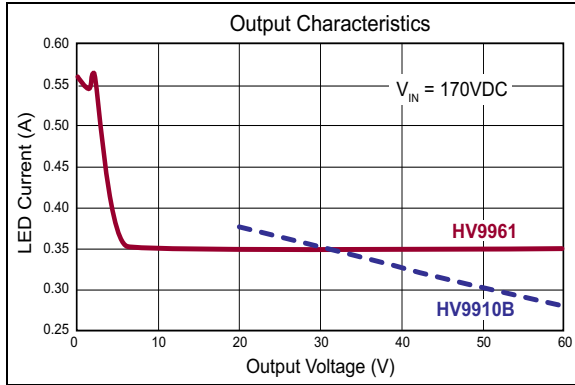

**FIGURE 3-1:** Typical Output Characteristic of an HV9961 LED Driver.

The short-circuit protection comparator trips when the voltage at CS exceeds  $0.44V$ . When this occurs, the short-circuit gate off-time  $T_{HICCUP} = 400 \mu s$  is generated to prevent the staircasing of the inductor current and, potentially, its saturation due to insufficient output voltage. The typical short-circuit inductor current is shown in the waveform of [Figure 3-2](#).

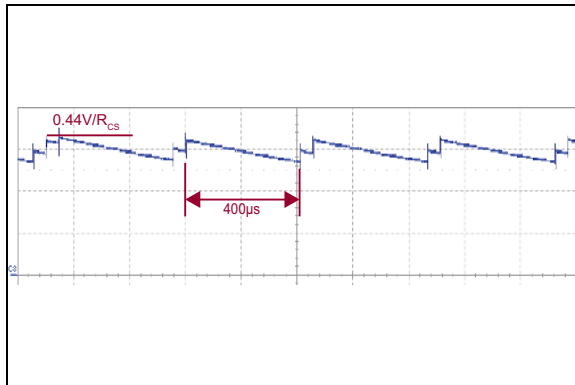
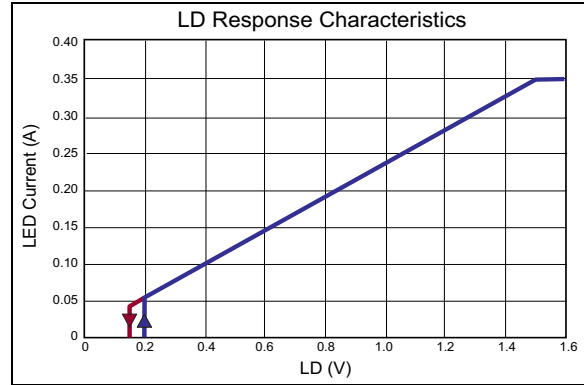

**FIGURE 3-2:** Short-circuit Inductor Current.

A leading-edge blanking delay is provided at CS to prevent false triggering of the current feedback and the short-circuit protection.

### 3.4 Linear Dimming

When the voltage at LD falls below  $1.5V$ , the internal  $275 \text{ mV}$  reference to the constant-current feedback becomes overridden by  $V_{LD} \times 0.185$ . As long as the current in the inductor remains continuous, the LED current is given by [Equation 3-3](#). However, when  $V_{LD}$  falls below  $150 \text{ mV}$ , the gate output becomes disabled. The gate signal recovers when  $V_{LD}$  exceeds  $200 \text{ mV}$ . It is required in some applications to use the same brightness control signal input to shut off the lamp. The typical linear dimming response is shown in [Figure 3-3](#).



**FIGURE 3-3:** Typical Linear Dimming Response of an HV9961 LED Driver.

The linear dimming input could also be used for “mixed-mode” dimming to expand the dimming ratio. In such case, a pulse-width modulated signal with an amplitude below  $1.5V$  should be applied to LD.

### 3.5 Input Voltage Regulator

The HV9961 can be powered directly from an  $8 V_{DC} - 450 V_{DC}$  supply through its  $V_{IN}$  input. When this voltage is applied at the  $V_{IN}$  pin, the HV9961 maintains a constant  $7.5V$  level at  $V_{DD}$ . This voltage can be used to power the IC and external circuitry connected to  $V_{DD}$  within the rated maximum current or within the thermal ratings of the package, whichever limit is lower. The  $V_{DD}$  pin must be bypassed by a low ESR capacitor to provide a low-impedance path for the high-frequency current of the gate output. The HV9961 can also be powered through the  $V_{DD}$  pin directly with a voltage greater than the internally regulated  $7.5V$ , but less than  $12V$ .

Despite the instantaneous voltage rating of  $450V$ , continuous voltage at  $V_{IN}$  is limited by the power dissipation in the package. For example, when HV9961 draws  $I_{IN} = 2.5 \text{ mA}$  from the  $V_{IN}$  input, and the 8-pin SOIC package is used, the maximum continuous voltage at  $V_{IN}$  is limited to the value shown in [Equation 3-5](#).

#### EQUATION 3-5:

$$V_{IN(MAX)} = \frac{T_{J(MAX)} - T_A}{R_{\theta,JA} \times I_{IN}} = 396V$$

Where:

Ambient temperature:  $T_A = 25^\circ C$

Maximum working junction temperature:  $T_{J(MAX)} = 125^\circ C$

Junction-to-ambient thermal resistance:

$R_{\theta,JA} = 101^\circ C/W$

# HV9961

In such cases, when it is needed to operate the HV9961 from a higher voltage, a resistor or a Zener diode can be added in series with the  $V_{IN}$  input to divert some of the power loss from the HV9961. In the above example, using a 100V Zener diode will allow the circuit to work up to 490V. The input current drawn from the  $V_{IN}$  pin is represented by Equation 3-6.

## EQUATION 3-6:

$$I_{IN} \approx I_{mA} + Q_G \times f_S$$

Where:

$f_S$  = Switching frequency

$Q_G$  = Gate charge of the external FET (obtained from the manufacturer's data sheet)

## 3.6 Gate Output

The gate output of the HV9961 is used to drive an external MOSFET. It is recommended that the gate charge  $Q_G$  of the external MOSFET be less than 25 nC for switching frequencies  $\leq 100$  kHz and less than 15 nC for switching frequencies  $> 100$  kHz.

## 3.7 PWM Dimming

Due to the fast open-loop response of the average-current control loop of the HV9961, its PWM dimming performance nearly matches that of the HV9910B. The inductor current waveform comparison is shown in Figure 3-4.

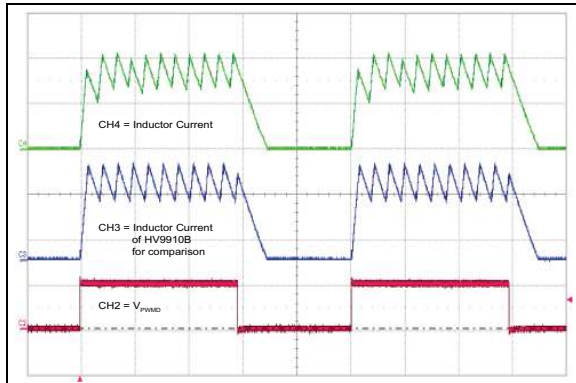

**FIGURE 3-4:** Typical PWM Dimming Response of an HV9961 LED Driver.

The rising and falling edges are limited by the current slew rate in the inductor. The first switching cycle is terminated upon reaching the 275 mV or  $V_{LD} \times 0.185$  level at CS. The circuit is further reaching its steady-state within 3–4 switching cycles regardless of the switching frequency.

## 4.0 PACKAGING INFORMATION

### 4.1 Package Marking Information

8-lead SOIC

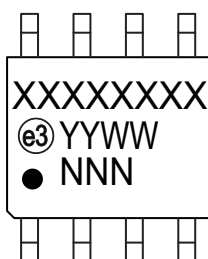

Example

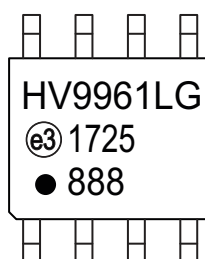

16-lead SOIC

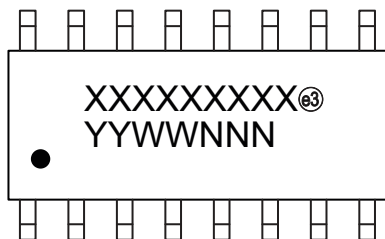

Example

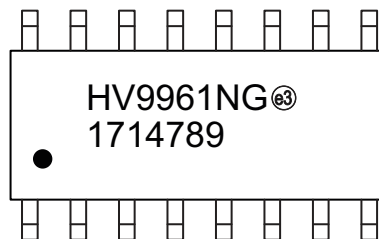

**Legend:** XX...X Product code or customer-specific information  
 Y Year code (last digit of calendar year)  
 YY Year code (last 2 digits of calendar year)  
 WW Week code (week of January 1 is week '01')  
 NNN Alphanumeric traceability code  
 (e3) Pb-free JEDEC® designator for Matte Tin (Sn)  
 \* This package is Pb-free. The Pb-free JEDEC designator (e3) can be found on the outer packaging for this package.

●, ▲, ▼ Pin one index is identified by a dot, delta up, or delta down (triangle mark).

**Note:** In the event the full Microchip part number cannot be marked on one line, it will be carried over to the next line, thus limiting the number of available characters for customer-specific information. Package may or may not include the corporate logo.

Underbar ( ¯ ) and/or Overbar ( ¸ ) symbol may not be to scale.

# HV9961

## 8-Lead Plastic Small Outline (SN) - Narrow, 3.90 mm (.150 In.) Body [SOIC]

**Note:** For the most current package drawings, please see the Microchip Packaging Specification located at <http://www.microchip.com/packaging>

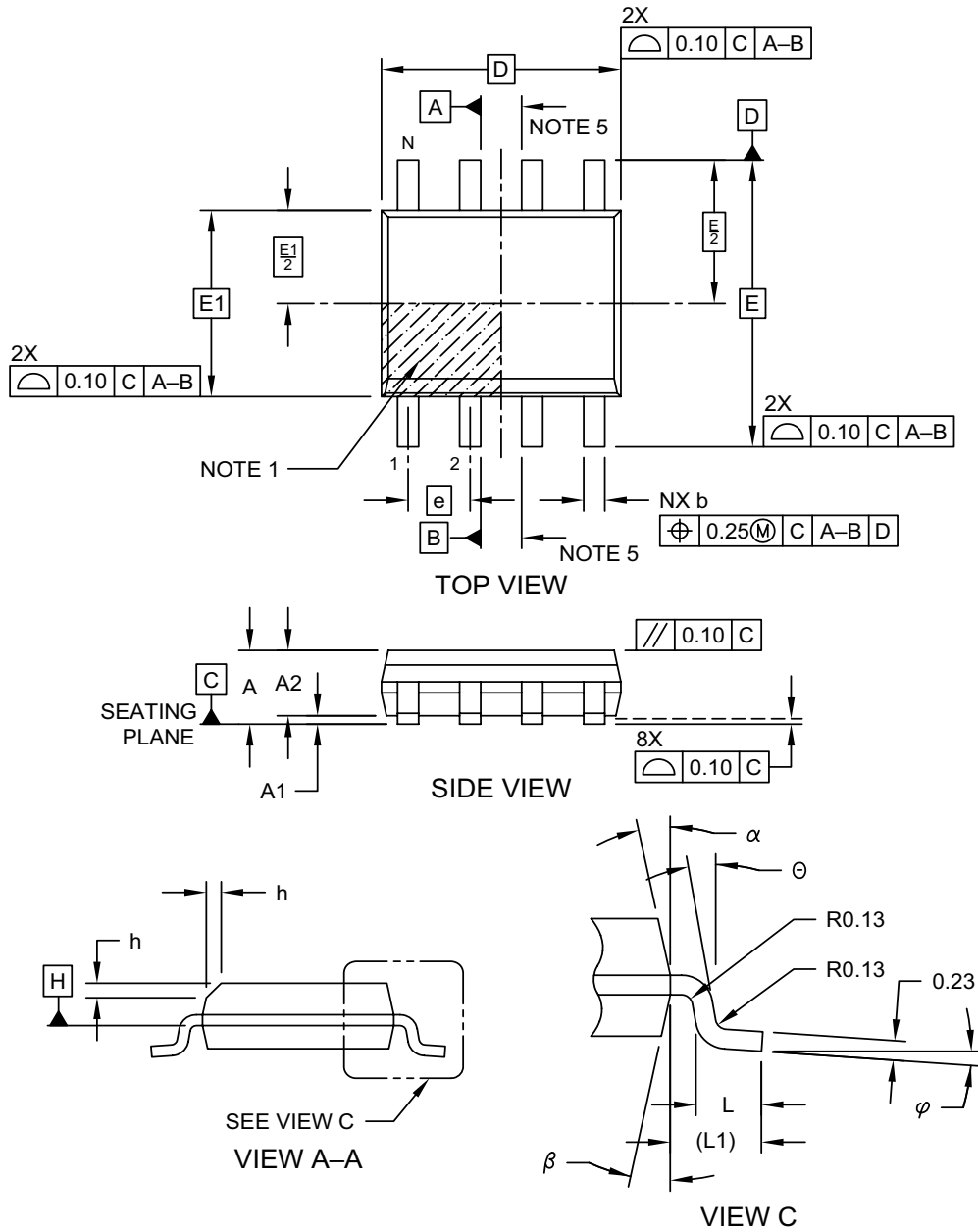

Microchip Technology Drawing No. C04-057-SN Rev F Sheet 1 of 2

## 8-Lead Plastic Small Outline (SN) - Narrow, 3.90 mm (.150 In.) Body [SOIC]

**Note:** For the most current package drawings, please see the Microchip Packaging Specification located at <http://www.microchip.com/packaging>

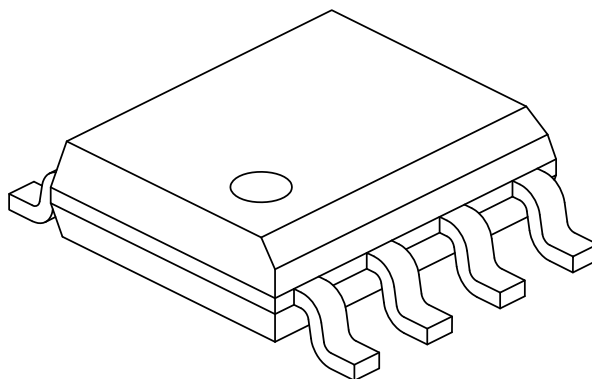

Dimension Limits	Units	MILLIMETERS		
		MIN	NOM	MAX
Number of Pins	N	8		
Pitch	e	1.27 BSC		
Overall Height	A	-	-	1.75
Molded Package Thickness	A2	1.25	-	-
Standoff §	A1	0.10	-	0.25
Overall Width	E	6.00 BSC		
Molded Package Width	E1	3.90 BSC		
Overall Length	D	4.90 BSC		
Chamfer (Optional)	h	0.25	-	0.50
Foot Length	L	0.40	-	1.27
Footprint	L1	1.04 REF		
Foot Angle	$\varphi$	0°	-	8°
Lead Thickness	c	0.17	-	0.25
Lead Width	b	0.31	-	0.51
Mold Draft Angle Top	$\alpha$	5°	-	15°
Mold Draft Angle Bottom	$\beta$	5°	-	15°

**Notes:**

- Pin 1 visual index feature may vary, but must be located within the hatched area.
- § Significant Characteristic
- Dimensions D and E1 do not include mold flash or protrusions. Mold flash or protrusions shall not exceed 0.15mm per side.
- Dimensioning and tolerancing per ASME Y14.5M  
BSC: Basic Dimension. Theoretically exact value shown without tolerances.  
REF: Reference Dimension, usually without tolerance, for information purposes only.
- Datums A & B to be determined at Datum H.

Microchip Technology Drawing No. C04-057-SN Rev F Sheet 2 of 2

## 8-Lead Plastic Small Outline (SN) - Narrow, 3.90 mm (.150 In.) Body [SOIC]

**Note:** For the most current package drawings, please see the Microchip Packaging Specification located at <http://www.microchip.com/packaging>

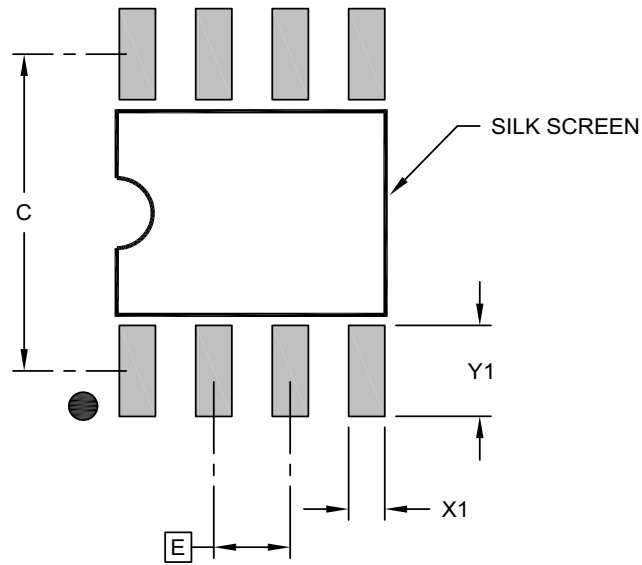

RECOMMENDED LAND PATTERN

Dimension Limits	Units	MILLIMETERS		
		MIN	NOM	MAX
Contact Pitch	E	1.27 BSC		
Contact Pad Spacing	C		5.40	
Contact Pad Width (X8)	X1			0.60
Contact Pad Length (X8)	Y1			1.55

**Notes:**

1. Dimensioning and tolerancing per ASME Y14.5M

BSC: Basic Dimension. Theoretically exact value shown without tolerances.

Microchip Technology Drawing C04-2057-SN Rev F

## 16-Lead Plastic Small Outline (SL) - Narrow, 3.90 mm Body [SOIC]

**Note:** For the most current package drawings, please see the Microchip Packaging Specification located at <http://www.microchip.com/packaging>

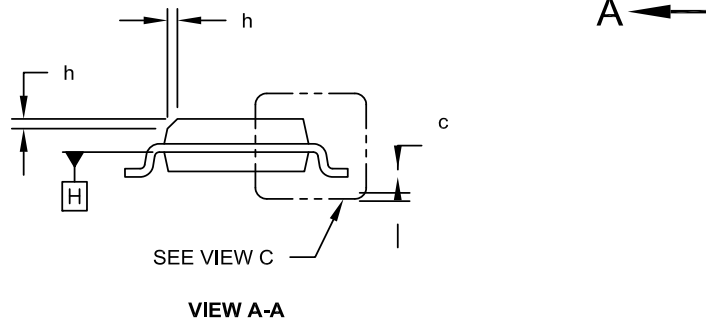
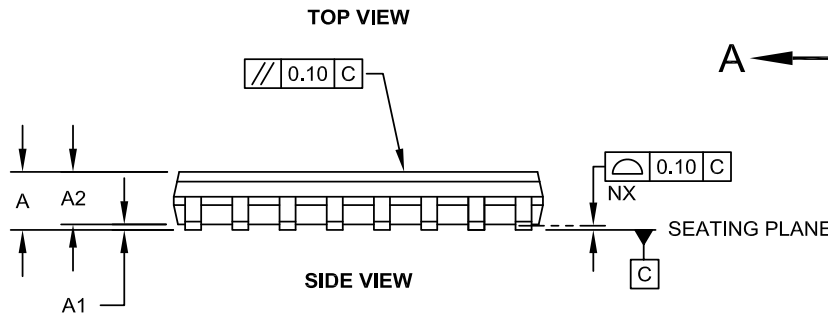
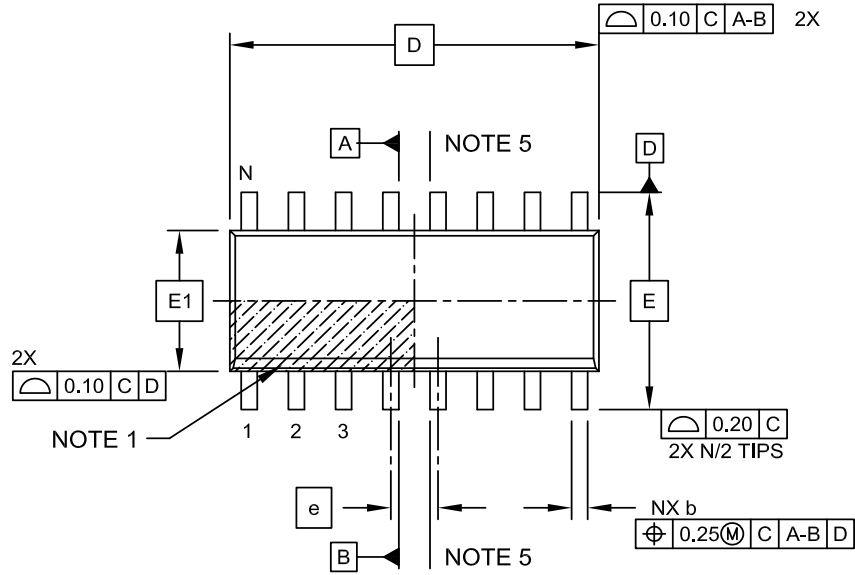

Microchip Technology Drawing No. C04-108C Sheet 1 of 2

## 16-Lead Plastic Small Outline (SL) - Narrow, 3.90 mm Body [SOIC]

**Note:** For the most current package drawings, please see the Microchip Packaging Specification located at <http://www.microchip.com/packaging>

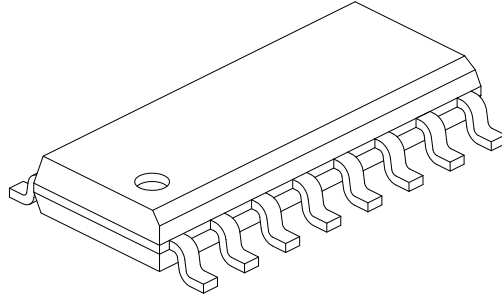
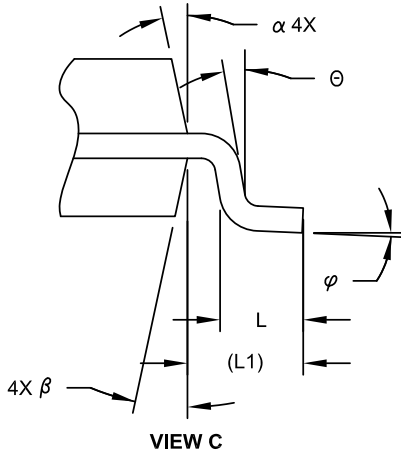

Dimension Limits	Units	MILLIMETERS		
		MIN	NOM	MAX
Number of Pins	N	16		
Pitch	e	1.27 BSC		
Overall Height	A	-	-	1.75
Molded Package Thickness	A2	1.25	-	-
Standoff §	A1	0.10	-	0.25
Overall Width	E	6.00 BSC		
Molded Package Width	E1	3.90 BSC		
Overall Length	D	9.90 BSC		
Chamfer (Optional)	h	0.25	-	0.50
Foot Length	L	0.40	-	1.27
Footprint	L1	1.04 REF		
Lead Angle	θ	0°	-	-
Foot Angle	φ	0°	-	8°
Lead Thickness	c	0.10	-	0.25
Lead Width	b	0.31	-	0.51
Mold Draft Angle Top	α	5°	-	15°
Mold Draft Angle Bottom	β	5°	-	15°

**Notes:**

- Pin 1 visual index feature may vary, but must be located within the hatched area.
- § Significant Characteristic
- Dimension D does not include mold flash, protrusions or gate burrs, which shall not exceed 0.15 mm per end. Dimension E1 does not include interlead flash or protrusion, which shall not exceed 0.25 mm per side.
- Dimensioning and tolerancing per ASME Y14.5M  
 BSC: Basic Dimension. Theoretically exact value shown without tolerances.  
 REF: Reference Dimension, usually without tolerance, for information purposes only.
- Datums A & B to be determined at Datum H.

Microchip Technology Drawing No. C04-108C Sheet 2 of 2

## 16-Lead Plastic Small Outline (SL) - Narrow, 3.90 mm Body [SOIC]

**Note:** For the most current package drawings, please see the Microchip Packaging Specification located at <http://www.microchip.com/packaging>

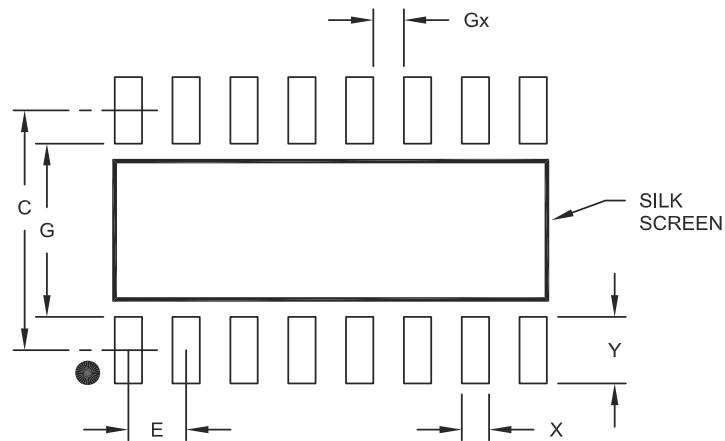

### RECOMMENDED LAND PATTERN

Dimension Limits	Units	MILLIMETERS		
		MIN	NOM	MAX
Contact Pitch	E		1.27 BSC	
Contact Pad Spacing	C		5.40	
Contact Pad Width	X			0.60
Contact Pad Length	Y			1.50
Distance Between Pads	Gx	0.67		
Distance Between Pads	G	3.90		

**Notes:**

1. Dimensioning and tolerancing per ASME Y14.5M

BSC: Basic Dimension. Theoretically exact value shown without tolerances.

Microchip Technology Drawing No. C04-2108A

# HV9961

---

---

NOTES:

## APPENDIX A: REVISION HISTORY

### Revision B (March 2022)

- Changed package drawings.
- Updated [Section “Electrical Characteristics”](#).
- Updated [Section “Temperature Specifications”](#).
- Minor format changes throughout.

### Revision A (November 2017)

- Converted Supertex Doc# DSFP-HV9961 to Microchip DS20005588A.
- Changed the package marking format.
- Changed the packaging quantity of the LG package from 2500/Reel to 3300/Reel.
- Changed the packaging quantity of the NG M901 media type from 1000/Reel to 2600/Reel.
- Changed the packaging quantity of the NG M934 media type from 2500/Reel to 2600/Reel.
- Made minor text changes throughout the document.

# HV9961

## PRODUCT IDENTIFICATION SYSTEM

To order or obtain information, e.g., on pricing or delivery, contact your local Microchip representative or sales office.

<u>PART NO.</u>	<u>XX</u>	<u>-X</u>	<u>-X</u>	<b>Examples:</b>
Device	Package Options	Environmental	Media Type	
Device: HV9961	=	LED Driver with Average-Current Mode Constant-Current Control		a) HV9961LG-G: LED Driver with Average-Current Mode Constant-Current Control, 8-lead SOIC, 3300/Reel
Packages: LG	=	8-lead SOIC		b) HV9961NG-G: LED Driver with Average-Current Mode Constant-Current Control, 16-lead SOIC, 45/Tube
NG	=	16-lead SOIC		c) HV9961NG-G-M901: LED Driver with Average-Current Mode Constant-Current Control, 16-lead SOIC, 2600/Reel
Environmental: G	=	Lead (Pb)-free/RoHS-compliant Package		d) HV9961NG-G-M934: LED Driver with Average-Current Mode Constant-Current Control, 16-lead SOIC, 2600/Reel
Media Types: (blank)	=	3300/Reel for an LG Package		
(blank)	=	45/Tube for an NG Package		
M901	=	2600/Reel for an NG Package		
M934	=	2600/Reel for an NG Package		
<b>Note:</b>	For Media Types M901 and M934, the base quantity for tape and reel was standardized to 2600/reel. Both options will result in the delivery of the same number of parts/reel.			<b>Note 1:</b> Tape and Reel identifier only appears in the catalog part number description. This identifier is used for ordering purposes and is not printed on the device package. Check with your Microchip Sales Office for package availability with the Tape and Reel option.

---

---

**Note the following details of the code protection feature on Microchip products:**

- Microchip products meet the specifications contained in their particular Microchip Data Sheet.
- Microchip believes that its family of products is secure when used in the intended manner, within operating specifications, and under normal conditions.
- Microchip values and aggressively protects its intellectual property rights. Attempts to breach the code protection features of Microchip product is strictly prohibited and may violate the Digital Millennium Copyright Act.
- Neither Microchip nor any other semiconductor manufacturer can guarantee the security of its code. Code protection does not mean that we are guaranteeing the product is “unbreakable”. Code protection is constantly evolving. Microchip is committed to continuously improving the code protection features of our products.

---

This publication and the information herein may be used only with Microchip products, including to design, test, and integrate Microchip products with your application. Use of this information in any other manner violates these terms. Information regarding device applications is provided only for your convenience and may be superseded by updates. It is your responsibility to ensure that your application meets with your specifications. Contact your local Microchip sales office for additional support or, obtain additional support at <https://www.microchip.com/en-us/support/design-help/client-support-services>.

THIS INFORMATION IS PROVIDED BY MICROCHIP "AS IS". MICROCHIP MAKES NO REPRESENTATIONS OR WARRANTIES OF ANY KIND WHETHER EXPRESS OR IMPLIED, WRITTEN OR ORAL, STATUTORY OR OTHERWISE, RELATED TO THE INFORMATION INCLUDING BUT NOT LIMITED TO ANY IMPLIED WARRANTIES OF NON-INFRINGEMENT, MERCHANTABILITY, AND FITNESS FOR A PARTICULAR PURPOSE, OR WARRANTIES RELATED TO ITS CONDITION, QUALITY, OR PERFORMANCE.

IN NO EVENT WILL MICROCHIP BE LIABLE FOR ANY INDIRECT, SPECIAL, PUNITIVE, INCIDENTAL, OR CONSEQUENTIAL LOSS, DAMAGE, COST, OR EXPENSE OF ANY KIND WHATSOEVER RELATED TO THE INFORMATION OR ITS USE, HOWEVER CAUSED, EVEN IF MICROCHIP HAS BEEN ADVISED OF THE POSSIBILITY OR THE DAMAGES ARE FORESEEABLE. TO THE FULLEST EXTENT ALLOWED BY LAW, MICROCHIP'S TOTAL LIABILITY ON ALL CLAIMS IN ANY WAY RELATED TO THE INFORMATION OR ITS USE WILL NOT EXCEED THE AMOUNT OF FEES, IF ANY, THAT YOU HAVE PAID DIRECTLY TO MICROCHIP FOR THE INFORMATION.

Use of Microchip devices in life support and/or safety applications is entirely at the buyer's risk, and the buyer agrees to defend, indemnify and hold harmless Microchip from any and all damages, claims, suits, or expenses resulting from such use. No licenses are conveyed, implicitly or otherwise, under any Microchip intellectual property rights unless otherwise stated.

For information regarding Microchip's Quality Management Systems, please visit [www.microchip.com/quality](http://www.microchip.com/quality).

**Trademarks**

The Microchip name and logo, the Microchip logo, Adaptec, AnyRate, AVR, AVR logo, AVR Freaks, BesTime, BitCloud, CryptoMemory, CryptoRF, dsPIC, flexPWR, HELDO, IGLOO, JukeBlox, KeeLoq, Klear, LANCheck, LinkMD, maXStylus, maXTouch, MediaLB, megaAVR, Microsemi, Microsemi logo, MOST, MOST logo, MPLAB, OptoLyzer, PIC, picoPower, PICSTART, PIC32 logo, PolarFire, Prochip Designer, QTouch, SAM-BA, SenGenuity, SpyNIC, SST, SST Logo, SuperFlash, Symmetricom, SyncServer, Tachyon, TimeSource, tinyAVR, UNI/O, Vectron, and XMEGA are registered trademarks of Microchip Technology Incorporated in the U.S.A. and other countries.

AgileSwitch, APT, ClockWorks, The Embedded Control Solutions Company, EtherSynch, Flashtec, Hyper Speed Control, HyperLight Load, IntelliMOS, Libero, motorBench, mTouch, Powermite 3, Precision Edge, ProASIC, ProASIC Plus, ProASIC Plus logo, QuietWire, SmartFusion, SyncWorld, Temux, TimeCesium, TimeHub, TimePictra, TimeProvider, TrueTime, WinPath, and ZL are registered trademarks of Microchip Technology Incorporated in the U.S.A.

Adjacent Key Suppression, AKS, Analog-for-the-Digital Age, Any Capacitor, AnyIn, AnyOut, Augmented Switching, BlueSky, BodyCom, CodeGuard, CryptoAuthentication, CryptoAutomotive, CryptoCompanion, CryptoController, dsPICDEM, dsPICDEM.net, Dynamic Average Matching, DAM, ECAN, Espresso T1S, EtherGREEN, GridTime, IdealBridge, In-Circuit Serial Programming, ICSP, INICnet, Intelligent Paralleling, Inter-Chip Connectivity, JitterBlocker, Knob-on-Display, maxCrypto, maxView, memBrain, Mindi, MiWi, MPASM, MPF, MPLAB Certified logo, MPLIB, MPLINK, MultiTRAK, NetDetach, NVM Express, NVMe, Omniscient Code Generation, PICDEM, PICDEM.net, PICKit, PICtail, PowerSmart, PureSilicon, QMatrix, REAL ICE, Ripple Blocker, RTAX, RTG4, SAM-ICE, Serial Quad I/O, simpleMAP, SimpliPHY, SmartBuffer, SmartHLS, SMART-I.S., storClad, SQL, SuperSwitcher, SuperSwitcher II, Switchtec, SynchroPHY, Total Endurance, TSHARC, USBCheck, VariSense, VectorBlox, VeriPHY, ViewSpan, WiperLock, XpressConnect, and ZENA are trademarks of Microchip Technology Incorporated in the U.S.A. and other countries.

SQTP is a service mark of Microchip Technology Incorporated in the U.S.A.

The Adaptec logo, Frequency on Demand, Silicon Storage Technology, Symmcom, and Trusted Time are registered trademarks of Microchip Technology Inc. in other countries.

GestIC is a registered trademark of Microchip Technology Germany II GmbH & Co. KG, a subsidiary of Microchip Technology Inc., in other countries.

All other trademarks mentioned herein are property of their respective companies.

© 2017-2022, Microchip Technology Incorporated and its subsidiaries.

All Rights Reserved.

ISBN: 978-1-6683-0082-4



# MICROCHIP

## Worldwide Sales and Service

### AMERICAS

**Corporate Office**  
2355 West Chandler Blvd.  
Chandler, AZ 85224-6199  
Tel: 480-792-7200  
Fax: 480-792-7277  
Technical Support:  
[http://www.microchip.com/  
support](http://www.microchip.com/support)  
Web Address:  
[www.microchip.com](http://www.microchip.com)

#### Atlanta

Duluth, GA  
Tel: 678-957-9614  
Fax: 678-957-1455

#### Austin, TX

Tel: 512-257-3370

#### Boston

Westborough, MA  
Tel: 774-760-0087  
Fax: 774-760-0088

#### Chicago

Itasca, IL  
Tel: 630-285-0071  
Fax: 630-285-0075

#### Dallas

Addison, TX  
Tel: 972-818-7423  
Fax: 972-818-2924

#### Detroit

Novi, MI  
Tel: 248-848-4000

#### Houston, TX

Tel: 281-894-5983

#### Indianapolis

Noblesville, IN  
Tel: 317-773-8323  
Fax: 317-773-5453  
Tel: 317-536-2380

#### Los Angeles

Mission Viejo, CA  
Tel: 949-462-9523  
Fax: 949-462-9608  
Tel: 951-273-7800

#### Raleigh, NC

Tel: 919-844-7510

#### New York, NY

Tel: 631-435-6000

#### San Jose, CA

Tel: 408-735-9110  
Tel: 408-436-4270

#### Canada - Toronto

Tel: 905-695-1980  
Fax: 905-695-2078

### ASIA/PACIFIC

**Australia - Sydney**  
Tel: 61-2-9868-6733

**China - Beijing**  
Tel: 86-10-8569-7000

**China - Chengdu**  
Tel: 86-28-8665-5511

**China - Chongqing**  
Tel: 86-23-8980-9588

**China - Dongguan**  
Tel: 86-769-8702-9880

**China - Guangzhou**  
Tel: 86-20-8755-8029

**China - Hangzhou**  
Tel: 86-571-8792-8115

**China - Hong Kong SAR**  
Tel: 852-2943-5100

**China - Nanjing**  
Tel: 86-25-8473-2460

**China - Qingdao**  
Tel: 86-532-8502-7355

**China - Shanghai**  
Tel: 86-21-3326-8000

**China - Shenyang**  
Tel: 86-24-2334-2829

**China - Shenzhen**  
Tel: 86-755-8864-2200

**China - Suzhou**  
Tel: 86-186-6233-1526

**China - Wuhan**  
Tel: 86-27-5980-5300

**China - Xian**  
Tel: 86-29-8833-7252

**China - Xiamen**  
Tel: 86-592-2388138

**China - Zhuhai**  
Tel: 86-756-3210040

### ASIA/PACIFIC

**India - Bangalore**  
Tel: 91-80-3090-4444

**India - New Delhi**  
Tel: 91-11-4160-8631

**India - Pune**  
Tel: 91-20-4121-0141

**Japan - Osaka**  
Tel: 81-6-6152-7160

**Japan - Tokyo**  
Tel: 81-3-6880-3770

**Korea - Daegu**  
Tel: 82-53-744-4301

**Korea - Seoul**  
Tel: 82-2-554-7200

**Malaysia - Kuala Lumpur**  
Tel: 60-3-7651-7906

**Malaysia - Penang**  
Tel: 60-4-227-8870

**Philippines - Manila**  
Tel: 63-2-634-9065

**Singapore**  
Tel: 65-6334-8870

**Taiwan - Hsin Chu**  
Tel: 886-3-577-8366

**Taiwan - Kaohsiung**  
Tel: 886-7-213-7830

**Taiwan - Taipei**  
Tel: 886-2-2508-8600

**Thailand - Bangkok**  
Tel: 66-2-694-1351

**Vietnam - Ho Chi Minh**  
Tel: 84-28-5448-2100

### EUROPE

**Austria - Wels**  
Tel: 43-7242-2244-39  
Fax: 43-7242-2244-393

**Denmark - Copenhagen**  
Tel: 45-4485-5910  
Fax: 45-4485-2829

**Finland - Espoo**  
Tel: 358-9-4520-820

**France - Paris**  
Tel: 33-1-69-53-63-20  
Fax: 33-1-69-30-90-79

**Germany - Garching**  
Tel: 49-8931-9700

**Germany - Haan**  
Tel: 49-2129-3766400

**Germany - Heilbronn**  
Tel: 49-7131-72400

**Germany - Karlsruhe**  
Tel: 49-721-625370

**Germany - Munich**  
Tel: 49-89-627-144-0  
Fax: 49-89-627-144-44

**Germany - Rosenheim**  
Tel: 49-8031-354-560

**Israel - Ra'anana**  
Tel: 972-9-744-7705

**Italy - Milan**  
Tel: 39-0331-742611  
Fax: 39-0331-466781

**Italy - Padova**  
Tel: 39-049-7625286

**Netherlands - Drunen**  
Tel: 31-416-690399  
Fax: 31-416-690340

**Norway - Trondheim**  
Tel: 47-7288-4388

**Poland - Warsaw**  
Tel: 48-22-3325737

**Romania - Bucharest**  
Tel: 40-21-407-87-50

**Spain - Madrid**  
Tel: 34-91-708-08-90  
Fax: 34-91-708-08-91

**Sweden - Gothenberg**  
Tel: 46-31-704-60-40

**Sweden - Stockholm**  
Tel: 46-8-5090-4654

**UK - Wokingham**  
Tel: 44-118-921-5800  
Fax: 44-118-921-5820