

Wiring Systems

G7□ Relay I/O Blocks and Cables	383
G70A I/O Terminal Bases	386
G70D Relay Output Terminal Blocks	387
G70R Relay Output Terminal Block	395
G7TC Relay I/O Terminal Blocks	398
G79 Cables	401
XW2□ I/O Terminal Blocks and Cables	403
XW2B I/O Terminal Blocks	405
XW2C I/O Terminal Blocks	408
XW2D I/O Terminal Blocks	409
XW2Z Cables	412
I/O Connecting Cable Selection Guide	416

Wiring Systems

Introduction to I/O Blocks, I/O Terminals, and I/O Block Bases

G70D, G7TC, and G70A-ZOC16

Unify Wiring with One Connecting Cable.

Simplify Connections to the Controller and Reduce Wiring in the Control Panel.

Improve Surge Suppression and Increase Capacity at the Same Time.

G70D

Compact Output Terminals Save Control Panel Space

- The G70D Series consists of 16-point Relay Output Terminals.
- Two configurations are available: The standard low-profile version is just 156 × 51 × 39 mm (W×D×H) and the vertical version is just 135 × 46 × 81 mm (W×D×H).
- Relay output models are equipped with G6D power relays (low-profile: SPST-NO 3 A/common; vertical: SPST-NO 3 A/output) and power MOSFET relay models are equipped with G3DZ power MOSFET relays (SPST-NO 0.3 A/output).
- The flat models have 2 common terminals. The vertical models have 16 independent outputs.

Note: See page 392 and page 387 for more details.

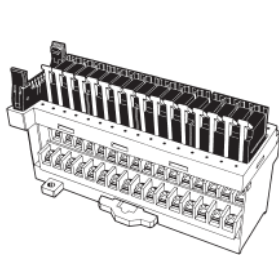

Vertical models
(G70D-VSOC16/VFOM16)

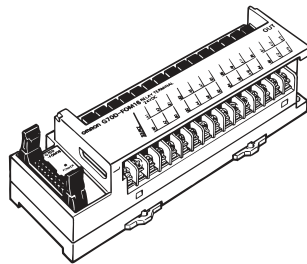

Low-profile models
(G70D-SOC16/FOM16)

G7TC

Both Input Blocks and Output Blocks are Available. G7TC I/O Blocks are Ideal as Controller Interfaces.

- Output Blocks with 8 or 16 outputs are available. Input Blocks with 16 inputs are available.
- The 16-point Output Blocks are available with PNP circuits.
- The 16-point models are just 182 × 85 × 68 mm (W×D×H) and the 8-point models are just 102 × 85 × 68 mm (W×D×H).
- Equipped with G7T I/O Relays (SPST-NO 5 A/output).
- G7TC models conform to UL and CSA standards.
- 16-point models with independent terminals.
- Models are also available with G3TA Solid State Relays.

Note: See page 398 for more details.

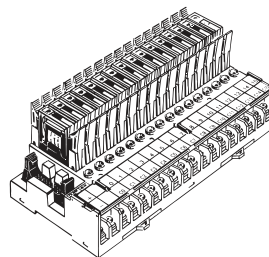

16-point model

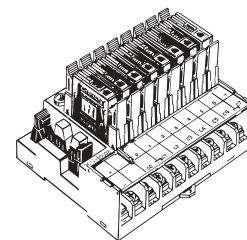

8-point model

G70A-ZOC16

High-capacity Relay Sockets can be Equipped with G2R (SPDT) Relays.

- Sixteen relay terminal sockets for output relays only.
- Models are available with PNP circuits.
- Compact case is just 234 × 75 × 64 mm (W×D×H).
- Install OMRON G2R Power Relays, G3R Solid State Relays, G3RZ Power MOSFET Relays, and H3RN Timers as required. (Relays and Timers are sold separately.)
- High-capacity 10-A Terminal Block
- Conforms to VDE standards.
- Sixteen independent terminals

Note: See page 386 for more details.

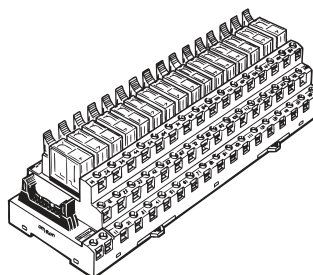

*Relays are sold separately.

G70D-SOC08

Space-saving and Labor-saving 8-point Output Block

- Compact terminal block is just 68 × 80 × 44 mm (W × H × D, when mounted upright).
- Independent contacts and shorting bars allow easy common connections.
- The common can now be connected with a shorting bar in the G70D-SOC08 and G70R-SOC08.
- No tools are required to remove Relays, so Relay replacement is easier than ever.
- The attached terminal cover prevents shocks.
- Equipped with operation indicators.
- Built-in diodes absorb coil surge.
- Mount either to DIN rail or via screws.

Note: See page 389 for details.



G70R-SOC08

Space-saving and Labor-saving 8-point Output Block

- Compact terminal block is just 136 × 80 × 55 mm (W × H × D, when mounted upright).
- Independent contacts and shorting bars allow easy common connections.
- The common can now be connected with a shorting bar in the G70D-SOC08 and G70R-SOC08.
- No tools are required to remove Relays, so Relay replacement is easier than ever.
- The attached terminal cover prevents shocks.
- Built-in diodes absorb coil surge.
- Mount either to DIN rail or via screws.

Note: See page 395 for details.



G70A-ZOC16

I/O Terminal Bases

16-point I/O Block accepts Various Devices such as G2R Relays, Solid State Relays, and Timers for More System Flexibility

- Connects to a PLC or SBC with a simple snap-in connector.
- The G70A-ZOC16-3 can be combined with a DRT1-OD32ML I/O Terminal for DeviceNet connectivity or an SRT2-VOD16ML Connector Terminal for CompoBus/S connectivity.
- SPDT relays can be mounted.
- Conforms to VDE (VDE0106) and CE standards.
- Electric-shock preventive (finger-touch protection) terminal block
- DIN rail mountable
- High-capacity (10 A) terminal block
- Excellent noise resistance characteristics
- Built-in diodes for coil surge suppression

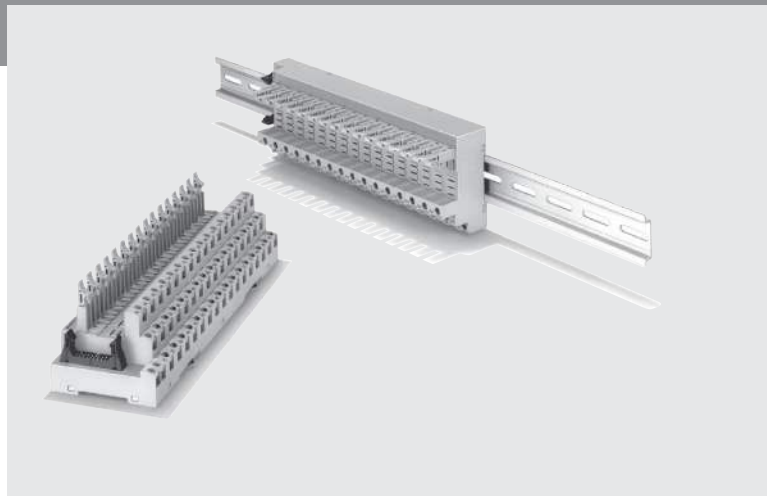

Ordering Information

Internal I/O circuit common	Rated voltage	Model	Compatible Relays/Timers (sold separately)
NPN compatible (+ common)	24 V DC	G70A-ZOC16-3	G2R-1-S (SPDT), G2R-1-SN (SPDT with indicator), G3R-OA202SZN, G3R-OA202SLN, G3R-ODX02SN, G3R-OD201SN, G3RZ-201SLN, H3RN-1, and H3RN-11
PNP compatible (- common)	24 V DC	G70A-ZOC16-4	

Note: Each relay to be mounted must incorporate a coil that has proper specifications within the maximum rated voltage range.

Specifications

Ratings/Characteristics

Item	G70A-ZOC16-3 and G70A-ZOC16-4	
Contact resistance	10 mΩ (excluding the resistance of the relay to be used)	
Permissible current	10 A	
Max. operating voltage	380 V AC, 125 V DC	
Terminal block	Dielectric strength	4,000 V AC, 50/60 Hz for 1 min between connector and output terminals 2,000 V AC, 50/60 Hz for 1 min between output terminals 250 V AC, 50/60 Hz for 1 min between connectors
	Insulation resistance	1,000 MΩ (at 250/500 V)
	Vibration resistance	Malfunction: 10 to 61.2 to 10 Hz, 0.1-mm double amplitude 0.2; 61.2 to 150 to 61.2 Hz, 14.7 m/s ²
Shock resistance	Malfunction: 200 m/s ² (approx. 20G)	
Noise immunity	Noise level: 2.0 kV; pulse width: 100 ns to 1 μs	
Ambient temperature	Operating: 0° C to 55° C (with no condensation or icing)	
Ambient humidity	Operating: 35% to 85%	
Coil surge absorption element	Diode: 1 A, 400 V	
Protection against reversed connection	Diode (2 A, withstand inverse voltage: 40 V)	
Tensile strength	No damage when a tensile force of 49 N is applied for 1 second in any direction	
I/O terminal tightening torque	Tightening strength: 0.59 N·m; Tensile strength 49 N for 1 min	
Weight	Approx. 400 g	

Accessories (Order Separately)

G79 Connecting Cables

Cable Type	Model
Cable with Loose Wire and Crimp Terminals	G79-Y□C
Cable with Loose Wires	G79-A□C
Cable with Three Connectors (1:3)	G79-□C-□-□
Cable with Two Connectors (1:2)	G79-□C-□
Cable with One Connector (1:1)	G79-□C

Short Bar

Applicable I/O block	Model
G70A-ZOC 16-4	G78-16-E

Note: See pages page 401 for details.

G70D

Relay output terminal blocks

Compact, Low-profile 16-point Output Block

- Compact terminal block is just 156 × 51 × 39 mm (W × D × H)
- Models with Power MOSFET Relays are available for high-frequency switching of AC or DC loads.
- Wire loads directly from terminal blocks; no need for relaying.
- Operation indicators show each I/O signal's ON/OFF status at a glance.
- The G70D-SOC16 and G70D-FOM16 can be combined with a DRT1-OD32ML I/O Terminal for DeviceNet connectivity or an SRT2-VOD16ML Connector Terminal for CompoBus/S connectivity.
- Equipped with surge-absorbing diodes.
- Relay Removal Tool included.
- Mount either to DIN rail or via screws.

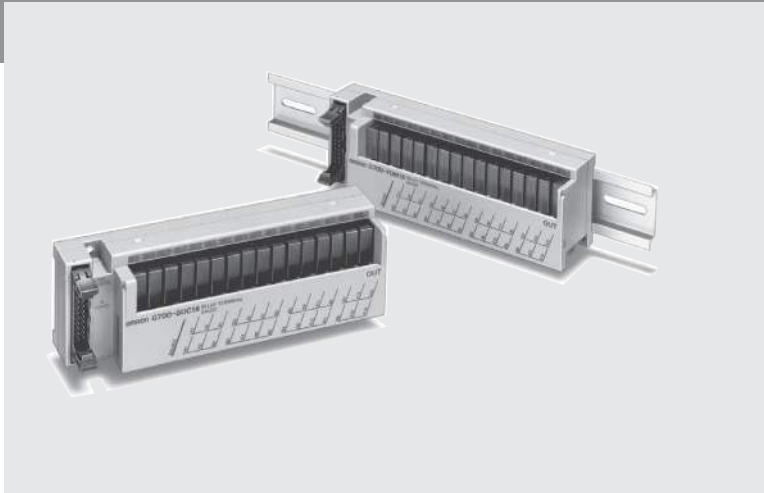

Ordering Information

Classification	Points	Internal output circuit common	Rated voltage	Model
Relay outputs	16 points (SPST-NO × 16)	NPN compatible (+common)	24 V DC	G70D-SOC16
		PNP compatible (– common)		G70D-SOC16-1
NPN compatible (+ common)		G70D-FOM16		
PNP compatible (– common)		G70D-FOM16-1		
Power MOSFET relay outputs				

These are all non-standard model and require a special order. Contact your OMRON representative for details on availability.

Specifications

Ratings

Relay Specifications

Note: The following specifications apply to G6D Relays mounted in a G70D Output Block and not the G6D Relay itself.

Coil Ratings (per G6D Relay)

Rated voltage	24 V DC
Rated current	10.5 mA
Coil resistance	2,880 Ω
Must-operate voltage	70% max. of rated voltage
Must release voltage	10% min. of rated voltage
Max. voltage	130% of rated voltage
Power consumption	Approx. 200 mW

- Note:**
1. The must-operate voltage is 75% or less of the rated voltage if the relay is mounted upside down.
 2. Rated current and coil resistance were measured at a coil temperature of 23° C with a tolerance of ±10%.
 3. Operating characteristics were measured at a coil temperature of 23° C.
 4. The maximum allowable voltage is the maximum value of the allowable voltage range for the relay coil operating power supply. There is no continuous allowance.
 5. The rated current includes the terminal's LED current.

Contact Ratings (per G6D Relay)

Load	Resistive load (cosφ = 1)
Rated load	3 A at 250 V AC, 3 A at 30 V DC
Rated carry current	3 A
Max. switching voltage	250 V AC, 30 V DC
Max. switching current	3 A
Min. permissible load (reference value) (see note 2)	10 mA at 5 V DC
Life expectancy	Electrical: 100,000 operations min. (under and at the rated load at 1,800 operations/hr) Mechanical: 20,000,000 operations min. (at 18,000 operations/hr)

- Note:**
1. Up to 3 A can be carried by the power supply terminals for outputs (terminals B0 to B7.)
 2. This value is for a switching frequency of 120 times per minute.

Power MOSFET Relay Specifications

Input (per G3DZ Power MOSFET Relay)

Rated voltage	24 V DC
Operating voltage	19.2 to 28.8 V DC
Voltage level	Must-operate Must release
	19.2 V DC max. 1 V DC min.
Input impedance	4 kΩ±20%
Rated current	8.2 mA±20%

Output (per G3DZ Power MOSFET Relay)

Load voltage	3 to 264 V AC, 3 to 125 V DC
Load current	100 µA to 0.3 A
Inrush current	6 A (10 ms)

Note: The rated current includes the terminal's LED current.

Characteristics

Item	G70D-SOC16(-1)	G70D-FOM16(-1)
Classification	Relay outputs	Power MOSFET relay outputs
Contact form	16 points (SPST-NO × 16)	
Contact mechanism	Single	---
Contact material	AgCdO	---
Contact resistance	100 mΩ max. (see note 2)	---
Isolation method	---	Photocoupler
Must-operate time	10 ms max. (see note 3)	6 ms max.
Release time	10 ms max. (see note 3)	---
Output ON-resistance	---	2.4 Ω max.
Open-state leakage current	---	10 µA max. (at 125 V DC)
Max. switching frequency	Mechanical:18,000 operations/hr Rated load:1,800 operations/hr	---
Insulation resistance	100 MΩ min. (at 500 V DC)	
Dielectric strength	2,000 V AC for 1 min between coil and contact	2,000 V AC for 1 min between input and output terminals
Noise immunity	Power input (normal mode): 600 V for 10 min with a pulse width of 100 ns to 1 µs Power input (common mode): 1.5 kV for 10 min with a pulse width of 100 ns to 1 µs Input cable (coiling): 1.5 kV for 10 min with a pulse width of 100 ns to 1 µs Unit body (coiling): 600 V for 10 min with a pulse width of 100 ns to 1 µs	
Vibration resistance	Destruction: 10 to 55 to 10 Hz, 0.5-mm amplitude (1.0-mm double) Malfunction: 10 to 55 to 10 Hz, 0.375-mm amplitude (0.75-mm double)	
Shock resistance	Destruction:300 m/s ² (approx. 30G), Malfunction:100 m/s ² (approx. 10G)	
Operating voltage range	24 V DC ^{+10%} / _{-15%}	
Current consumption	Approx. 300 mA at 24 V DC (see note 4)	Approx. 300 mA at 24 V DC (see note 5)
Cable length	Between block and controller: 5 m max. (reference value for AWG28) Between block and external device: Dependent on load	
LED color	Operation indicator: orange; power supply: green	
Coil surge absorber	Diode (400 V, 300 mA)	
Ambient temperature	Operating: 0° C to 55° C	
Ambient humidity	Operating: 35% to 85%	
Mounting strength	No damage when 5 kgf (49 N) pull load was applied for 1 s in all directions (except for 1 kgf (9.8 N) in direction of rail)	
Terminal strength	Tightening torque: 0.78 to 0.98 N·m), Pull strength: 49 N for 1 min	
Weight	Approx. 200 g	

- Note: 1. These values are initial values.
 2. Measurement condition: 1 A at 5 V DC
 3. Ambient temperature: 23° C
 4. Current consumption is when all points are ON and includes G6D Relay coil current but does not include any external load current.
 5. Current consumption is when all points are ON and includes G3DZ input current but does not include any external load current.

Accessories (Order Separately)

G79 Connecting Cables

Cable Type	Model
Cable with Loose Wire and Crimp Terminals	G79-Y□C
Cable with Loose Wires	G79-A□C
Cable with Three Connectors (1:3)	G79-□C-□-□
Cable with Two Connectors (1:2)	G79-□C-□
Cable with One Connector (1:1)	G79-□C

Note: See page 401 for details.

Replacement Relays

Applicable Output Block	Rated voltage	Model
G70D-SOC16 G70D-SOC16-1	24 V DC	G6D-1A
G70D-FOM16 G70D-FOM16-1	24 V DC	G3DZ-2R6PL (see note)

Note: This is a non-standard model and requires a special order. Contact your OMRON representative for details on availability.

G70D-SOC08

Relay Output Terminal Block

Space-saving and Labor-saving 8-point Output Block

- Compact terminal block is just 68 × 80 × 44 mm (W × H × D, when mounted upright)..
- Independent contacts and shorting bars allow easy common connections.
- The common can now be connected with a shorting bar in the G70D-SOC08 and G70R-SOC08.
- No tools are required to remove Relays, so Relay replacement is easier than ever.
- The attached terminal cover prevents shocks.
- Equipped with operation indicators.
- Built-in diodes absorb coil surge.
- Mount either to DIN rail or via screws.

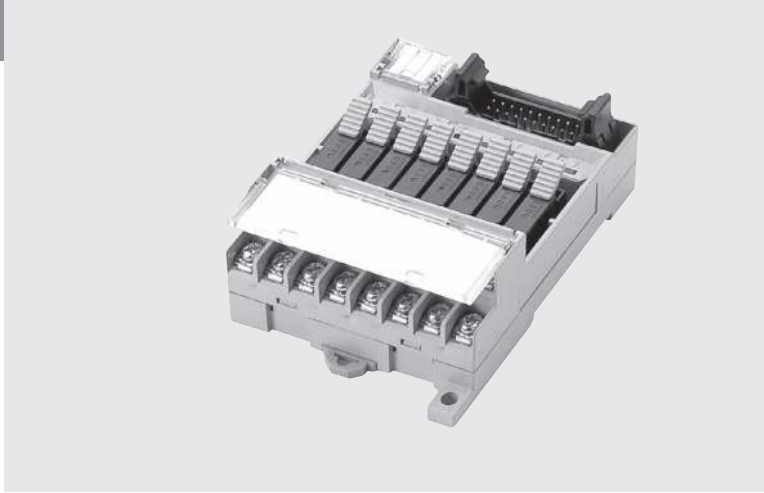

Ordering Information

Classification	Points	Internal output circuit common	Rated voltage	Model
Relay outputs	8 points (SPST-NO × 8)	NPN compatible (+ common)	24 V DC	G70D-SOC08

This is a non-standard model and requires a special order. Contact your OMRON representative for details on availability.

Specifications

Ratings

The following specifications apply to G6D Relays mounted in a G70D Output Block and not the G6D Relay itself.

Coil Ratings (per G6D Relay)

Rated voltage	Rated current	Coil resistance	Must-operate voltage	Release voltage	Max. allowable voltage	Power consumption
24 V DC	10.5 mA	2,880 Ω	70% max. of rated voltage	10% min. of rated voltage	130%	Approx. 200 mW

- Note:**
1. The must-operate voltage is 75% max. of the rated voltage if the Relay is mounted upside down.
 2. Rated current and coil resistance were measured at a coil temperature of 23° C with a tolerance of ±10%.
 3. Operating characteristics were measured at a coil temperature of 23° C.
 4. The maximum allowable voltage is the maximum value of the allowable voltage range for the relay coil operating power supply. There is no continuous allowance.
 5. The rated current includes the current consumption of the operation indicator.

Contact Ratings (per G6D Relay)

Item	Load	Resistive load (cosφ = 1)
Rated load		5 A at 250 V AC, 5 A at 30 V DC
Rated carry current		5 A
Max. switching voltage		250 V AC, 30 V DC
Max. switching current		5 A
Max. switching capacity (reference value)		1,250 VA, 150 W
Min. permissible load (reference value; see note.)		5 V DC, 10 mA
Life expectancy	Electrical	100,000 operations min. (at or below the rated load at 1,800 operations/hr)
	Mechanical	20,000,000 operations min. (at 18,000 operations/hr)

Note: This value is for a switching frequency of 120 times per minute.

Characteristics

		Model	G70D-SOC08
Item		Relay outputs	
Contact form		8 points (SPST-NO × 8)	
Contact mechanism		Single	
Contact resistance (See note 1.)		100 mΩ max.	
Must-operate time (See note 2.)		100 ms max.	
Release time (See note 3.)		10 ms max.	
Max. switching frequency	Mechanical	18,000 operations/hr	
	Rated load	1,800 operations/hr	
Insulation resistance		100 MΩ min. (at 500 V DC)	
Dielectric strength	Between coil and contact	2,000 V AC for 1 min	
	Between contacts of same polarity	750 V AC for 1 min	
	Between contacts of different polarity	1,500 V AC for 1 min	
Vibration resistance	Destruction	10 to 55 to 10 Hz, 0.5-mm amplitude (1.0-mm double)	
	Malfunction	10 to 55 to 10 Hz, 0.5-mm amplitude (1.0-mm double)	
Shock resistance	Destruction	300 m/s ²	
	Malfunction	100 m/s ²	
Noise immunity	Power input (normal mode)	600 V for 10 min with a pulse width of 100 ns to 1 μs	
	Power input (common mode)	1.5 kV for 10 min with a pulse width of 100 ns to 1 μs	
	Input cable (coiling)	1.5 kV for 10 min with a pulse width of 100 ns to 1 μs	
	Unit body (coiling)	600 V for 10 min with a pulse width of 100 ns to 1 μs	
Allowable power supply voltage fluctuation		24 V DC +10%/−15%	
Current consumption (See note 3.)		Approx. 80 mA at 24 V DC	
Cable length	Between block and controller	5 m max. (reference value for AWG 28)	
	Between block and external device	Determine appropriate length for the connected load.	
LED indicator color		Orange	
Coil surge absorber		Diode	
Ambient operating temperature		−10 to 55° C	
Ambient storage temperature		35% to 85%	
Ambient operating humidity		−20 to 65° C	
Mounting strength		No damage when 49 N pull load was applied for 1 s in all directions (except for 9.8 N min. in direction of track)	
Terminal strength	Tightening torque	9.8 N·m	
	Pull strength	49 N for 1 min	
Weight		Approx. 145 g	

- Note:**
1. These values are initial values.
 2. Measurement conditions: 1 A at 5 V DC
 3. Ambient temperature: 23° C
 4. The current consumption is the value when all points are ON and includes the G6D Relay coil current.

Engineering Data

Life expectancyMaximum switching capacity

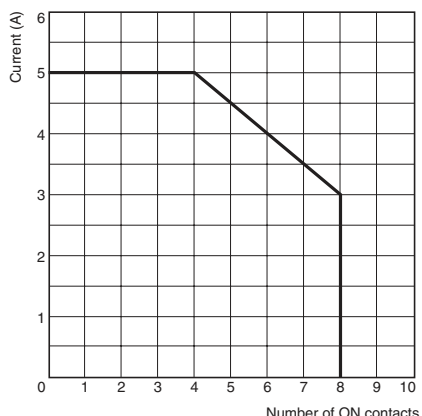
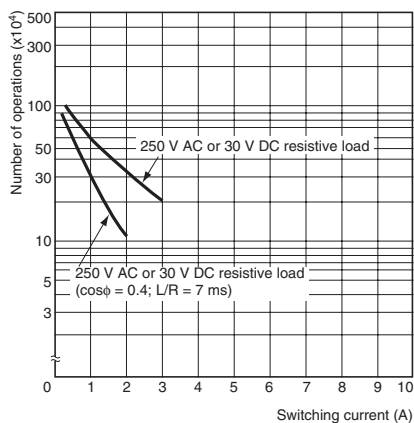

Note: The data shown in these graphs is based on actual values sampled from a production line; please use this data for reference only. As a general rule, allow for slight variations in the Relays because the Relays are mass produced.

- When using with a carry current of 5 A, no more than 4 contacts may be ON.
- The carry current is 3 A when all contacts are ON.

Accessories for the G70D-SOC08 (Order Separately)

Shorting Bar

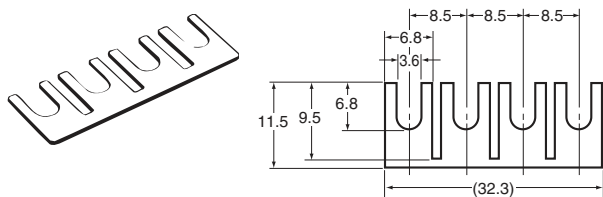

Applicable Output Block	Model
G70D-SOC08	G6B-4-SB

Replacement Relays

Applicable Output Block	Rated voltage	Model
G70D-SOC08	24 V DC	G6D-1A (See note.)
		G6D-1A-AP (See note.)

Note: The minimum permissible load (reference value) for the G6D-1A is 10 mA at 5 V DC.

G70D-VSOC16/-VFOM16

Relay output terminal blocks

Easy-to-use, Space-saving 16-point Output Block

- Slim terminal block is just 135 × 40 mm (W × D).
- Independent contacts and short bars allow easy common connections.
- An Expansion Terminal Block can be mounted for power line connections.
- M3.5 fork-type crimp terminals (with a maximum terminal width of 6.2 mm) can be used.
- Lever mechanism allows Relays to be installed and removed easily without tools.
- Relay models and power MOSFET Relay models are available.
- Equipped with operation indicators.
- Can be combined with a DRT1-OD32ML I/O Terminal for DeviceNet connectivity or an SRT2-VOD16ML Connector Terminal for CompoBus/S connectivity.
- Built-in diode absorbs coil surge.
- Mount either to DIN rail or via screws.

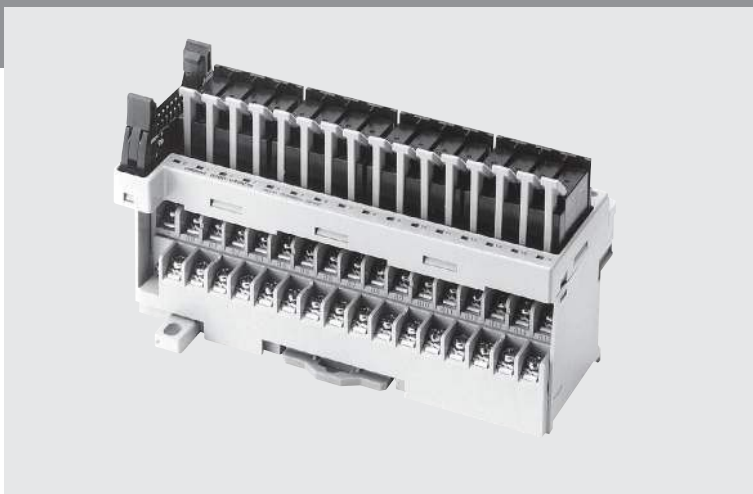

Ordering Information

Classification	Points	Internal output circuit common	Rated voltage	Model
Relay outputs	16 points (SPST-NO × 16)	NPN compatible (+ common)	24 V DC	G70D-VSOC16
Power MOSFET Relay outputs				G70D-VFOM16

These are all non-standard model and require a special order. Contact your OMRON representative for details on availability.

Specifications

Ratings

Relay Specifications

Note: The following specifications apply to G6D Relays mounted in a G70D Output Block and not the G6D Relay itself.

Coil Ratings (per G6D Relay)

Rated voltage	24 V DC
Rated current	10.5 mA
Coil resistance	2,880 Ω
Must-operate voltage	70% max. of rated voltage
Release voltage	10% min. of rated voltage
Max. allowable voltage	130% of rated voltage
Power consumption	Approx. 200 mW

- Note:**
1. The must-operate voltage is 75% max. of the rated voltage if the Relay is mounted upside down.
 2. Rated current and coil resistance were measured at a coil temperature of 23° C with a tolerance of ±10%.
 3. Operating characteristics were measured at a coil temperature of 23° C.
 4. The maximum allowable voltage is the maximum value of the allowable voltage range for the relay coil operating power supply. There is no continuous allowance.
 5. The rated current includes the current consumption of the operation indicator.

Contact Ratings (per G6D Relay)

Load	Resistive load (cosφ = 1)
Rated load	3 A at 250 V AC, 3 A at 30 V DC
Rated carry current	5 A (see note 1)
Max. switching voltage	250 V AC, 30 V DC
Max. switching current	5 A
Max. switching capacity	1,250 VA, 150 W
Min. permissible load (reference value) (See note .2)	5 V DC, 1 mA
Life expectancy	Electrical: 100,000 operations min. (under and at the rated load at 1,800 operations/hr), Mechanical: 20,000,000 operations min. (at 18,000 operations/hr)

- Note:**
1. Up to 5 A can be carried when 8 or fewer outputs are ON.
 2. This value is for a switching frequency of 120 times per minute.

Power MOSFET Relay Specifications

Note: The following values apply to G3DZ Relays mounted in a G70D Output Block and not the G3DZ Relay itself.

Input (per G3DZ Power MOSFET Relay)

Rated voltage	24 V DC	
Operating voltage	19.2 to 28.8 V DC	
Voltage level	Must operate	19.2 V DC max.
	Must release	1 V DC min.
Input impedance	4 kΩ±20%	
Rated current	8.2 mA±20%	

Output (per G3DZ Power MOSFET Relay)

Load voltage	3 to 264 V AC, 3 to 125 V DC	
Load current	100 μA to 0.3 A	
Inrush current	6 A (10 ms)	

Note: The rated current includes the current consumption of the operation indicator.

Characteristics

Item	G70D-VSOC16	G70D-VFOM16
	Relay outputs	
G70D-VSOC16		Power MOSFET Relay outputs
Contact form	16 points (SPST-NO × 16)	
Contact mechanism	Single	---
Contact resistance	100 mΩ max. (see note 2)	
Isolation method	---	Photocoupler
Must-operate time	10 ms max. (see note 3)	
Release time	10 ms max. (see note 3)	
Output ON-resistance	---	2.4 Ω max.
Open-circuit leakage current	---	10 μA max. (at 125 V DC)
Max. switching frequency	Mechanical: 18,000 operations/hr Rated load: 1,800 operations/hr	---
Insulation resistance	100 MΩ min. (at 500 V DC)	
Dielectric strength	2,000 V AC for 1 min between coil and contact	2,000 V AC for 1 min between input and output terminals
Noise immunity	Power input (normal mode): 600 V for 10 min with a pulse width of 100 ns to 1 μs Power input (common mode): 1.5 kV for 10 min with a pulse width of 100 ns to 1 μs Input cable (coiling): 1.5 kV for 10 min with a pulse width of 100 ns to 1 μs Unit body (coiling): 600 V for 10 min with a pulse width of 100 ns to 1 μs	
Vibration resistance	Destruction: 10 to 55 to 10 Hz, 0.5-mm amplitude (1.0-mm double) Malfunction: 10 to 55 to 10 Hz, 0.375-mm amplitude (0.75-mm double)	
Shock resistance	Destruction: 300 m/s ² . Malfunction: 100 m/s ²	
Operating voltage range	24 V DC ^{+10%} / _{-15%}	
Current consumption	Approx. 170 mA at 24 V DC (see note 4)	Approx. 125 mA at 24 V DC (see note 5)
Cable length	Between block and controller: 5 m max. (reference value for AWG28) Between block and external device: Dependent on load	
LED color	Operation indicator: orange	
Coil surge absorber	Diode (600 V, 1 A)	
Ambient temperature	Operating: -25°C to 55°C (with no icing or condensation)	
Ambient humidity	Operating: 45% to 85%	
Mounting strength	No damage when 49 N pull load was applied for 1 s in all directions (except for 9.8 N min. in direction of rail)	
Terminal strength	Tightening torque: 0.78 to 1.18 N·m, Pull strength: 49 N for 1 min	Tightening torque: 0.78 to 0.98 N·m, Pull strength: 49 N for 1 min
Weight (see note 6)	Approx. 280 g	

- Note:**
1. These values are initial values.
 2. Measurement condition: 1 A at 5 V DC
 3. Ambient temperature: 23°C
 4. Current consumption is when all points are ON and includes G6D Relay coil current but does not include any external load current.
 5. Current consumption is when all points are ON and includes G3DZ input current but does not include any external load current.
 6. The Unit weighs approximately 315 g with the Expansion Terminal Block mounted.

Accessories (Sold Separately)

G79 Connecting Cables

Cable Type	Model
Cable with Loose Wire and Crimp Terminals	G79-Y□C
Cable with Loose Wires	G79-A□C
Cable with Three Connectors (1:3)	G79-□C-□-□
Cable with Two Connectors (1:2)	G79-□C-□
Cable with One Connector (1:1)	G79-□C

Note: See page 401 for details.

Expansion Terminal Block

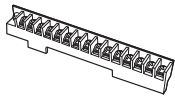
Applicable Output Block	Appearance	Model
G70D-VSOC16		G70D-ET (see note)
G70D-VFOM16		

Note: This is a non-standard model and requires a special order. Contact your OMRON representative for details on availability.

Short Bar

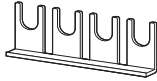
Applicable Output Block	Appearance	Model
G70D-VSOC16		G6D-4-SB
G70D-VFOM16		

Replacement Relays

Applicable Output Block	Rated voltage	Model
G70D-VSOC16	24 V DC	G6D-1A (see note 1)
	24 V DC	G6D-1A-AP (see notes 2 and 3)
G70D-VFOM16	24 V DC	G3DZ-2R6PL (see note 3)

- Note:**
1. The minimum permissible load (reference value) for the G6D-1A is 10 mA at 5 V DC.
 2. The minimum permissible load (reference value) for the G6D-1A-AP is 1 mA at 5 V DC.
 3. These are non-standard models and require a special order. Contact your OMRON representative for details on availability.

G70R-SOC08

Relay output terminal block

Space-saving and Labor-saving 8-point Output Block

- Compact terminal block is just 136 × 80 × 55 mm (W × H × D) when mounted upright).
- Independent contacts and shorting bars allow easy common connections.
- The common can now be connected with a shorting bar in the G70D-SOC08 and G70R-SOC08.
- No tools are required to remove Relays, so Relay replacement is easier than ever.
- The attached terminal cover prevents shocks.
- Built-in diodes absorb coil surge.
- Mount either to DIN rail or via screws.

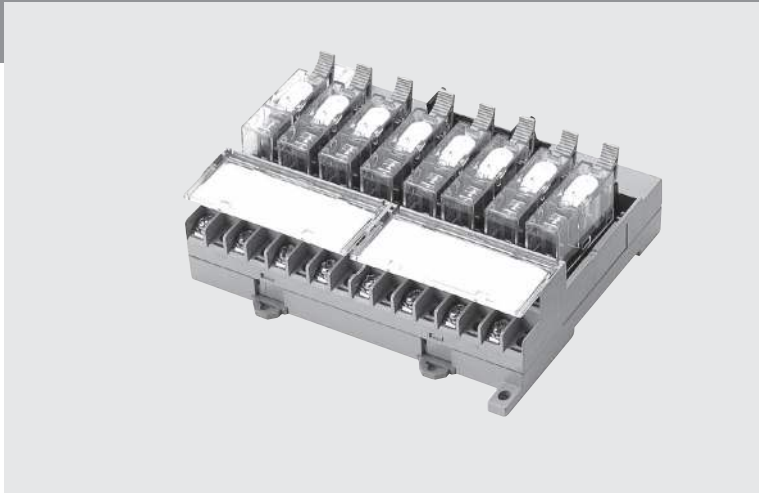

Ordering Information

Classification	Points	Internal output circuit common	Rated voltage	Model
Relay outputs	8 points (SPST-NO × 8)	NPN compatible (+ common)	24 V DC	G70R-SOC08

This is a non-standard model and requires a special order. Contact your OMRON representative for details on availability.

Specifications

Ratings

The following specifications apply to G2R Relays mounted in a G70R Output Block and not the G2R Relay itself.

Coil Ratings (per G2R Relay)

Rated voltage	Rated current	Coil resistance	Must-operate voltage	Release voltage	Max. allowable voltage	Power consumption
24 V DC	25.8 mA	1,100 Ω	70% max. of rated voltage	15% min. of rated voltage	130%	Approx. 530 mW

- Note:**
1. The must-operate voltage is 75% max. of the rated voltage if the Relay is mounted upside down.
 2. Rated current and coil resistance were measured at a coil temperature of 23° C with a tolerance of ±10%.
 3. Operating characteristics were measured at a coil temperature of 23° C.
 4. The maximum allowable voltage is the maximum value of the allowable voltage range for the relay coil operating power supply. There is no continuous allowance.
 5. The rated current includes the current consumption of the operation indicator.

Contact Ratings (per G2R Relay)

Item	Load	Resistive load (cosφ = 1)
Rated load		10 A at 250 V AC, 10 A at 30 V DC
Rated carry current		10 A
Max. switching voltage		380 V AC, 125 V DC
Max. switching current		10 A
Max. switching capacity (reference value)		2.50 VA, 300 W
Min. permissible load (reference value; see note.)		5 V DC, 10 mA
Life expectancy	Electrical	100,000 operations min. (at the rated load and 1,800 operations/hr)
	Mechanical	10,000,000 operations min. (at 18,000 operations/hr)

Note: This value is for a switching frequency of 120 times per minute.

Characteristics

Model		G70R-SOC08
Item	Relay outputs	
Contact form	8 points (SPST-NO × 8)	
Contact mechanism	Single	
Contact resistance (See note 1.)	30 mΩ max.	
Must-operate time (See note 2.)	15 ms max.	
Release time (See note 3.)	15 ms max.	
Max. switching frequency	Mechanical	18,000 operations/hr
	Rated load	1,800 operations/hr
Insulation resistance	100 MΩ min. (at 500 V DC)	
Dielectric strength	Between coil and contact	2,000 V AC for 1 min
	Between contacts of same polarity	750 V AC for 1 min
	Between contacts of different polarity	1,500 V AC for 1 min
Vibration resistance	Destruction	10 to 55 to 10 Hz, 0.5-mm amplitude (1.0-mm double)
	Malfunction	10 to 55 to 10 Hz, 0.5-mm amplitude (1.0-mm double)
Shock resistance	Destruction	300 m/s ²
	Malfunction	100 m/s ²
Noise immunity	Power input (normal mode)	600 V for 10 min with a pulse width of 100 ns to 1 μs
	Power input (common mode)	1.5 kV for 10 min with a pulse width of 100 ns to 1 μs
	Input cable (coiling)	1.5 kV for 10 min with a pulse width of 100 ns to 1 μs
	Unit body (coiling)	600 V for 10 min with a pulse width of 100 ns to 1 μs
Allowable power supply voltage fluctuation	24 V DC +10%/-15%	
Current consumption (See note 3.)	Approx. 185 mA at 24 V DC	
Cable length	Between block and controller	5 m max. (reference value for AWG 28)
	Between block and external device	Determine appropriate length for the connected load.
Coil surge absorber	Diode	
Ambient operating temperature	-10 to 55°C	
Ambient operating humidity	35% to 85%	
Ambient storage temperature	-20 to 65°C	
Mounting strength	No damage when 49 N pull load was applied for 1 s in all directions (except for 9.8 N min. in direction of track)	
Terminal strength	Tightening torque	0.98 N·m
	Pull strength	49 N for 1 min
Weight	Approx. 350 g	

- Note:**
1. These values are initial values.
 2. Measurement conditions: 1 A at 5 V DC
 3. Ambient temperature: 23°C
 4. The current consumption is the value when all points are ON and includes the G2R Relay coil current.

Engineering Data

Life expectancy Maximum switching capacity

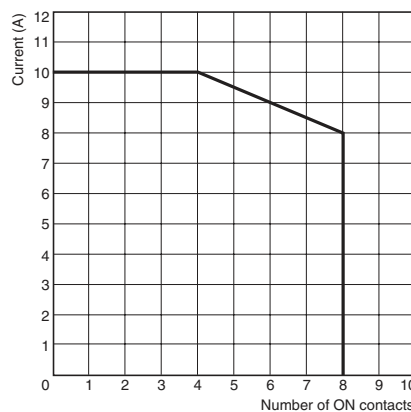
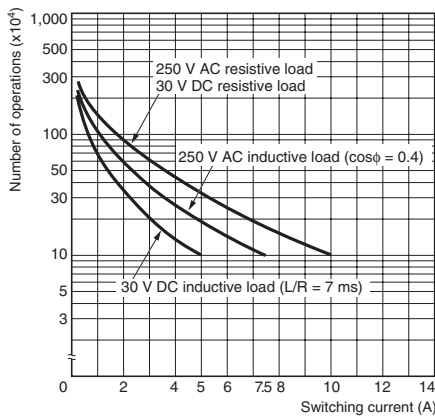

Note: The data shown in these graphs is based on actual values sampled from a production line; please use this data for reference only. As a general rule, allow for slight variations in the Relays because the Relays are mass produced.

- When using with a carry current of 10 A, no more than 4 contacts may be ON.
- The carry current is 8 A when all contacts are ON.

Accessories for the G70R-SOC08 (Order Separately)

Shorting Bar

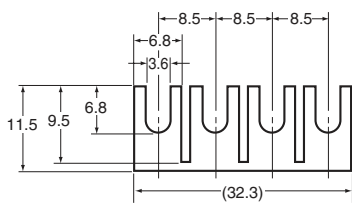
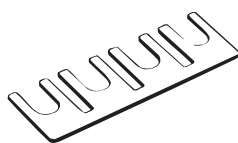

Applicable Output Block	Model
G70R-SOC08	G6B-4-SB

Replacement Relays

Applicable Output Block	Rated voltage	Model
G70R-SOC08	24 V DC	G2R-1-S
		G2R-1-SN

G7TC

Relay I/O terminal blocks

Unify PLC Wiring to a Single Cable to Reduce Wiring in the Control Panel and Save Space

- The 16-point Input and Output Blocks are just 182 × 85 × 68 mm (W × D × H) and the 8-point Output Block is just 102 × 85 × 68 mm (W × D × H).
- Also connects to an SBC with a simple snap-in connector.
- Surge suppressor circuit built-in.
- Operation indicators show each I/O signal's ON/OFF status at a glance.
- Mount to DIN rail.
- The G7TC-OC16 and G7TC-OC08 can be combined with a DRT1-OD32ML I/O Terminal for DeviceNet connectivity or an SRT2-VOD16ML Connector Terminal for CompoBus/S connectivity.
- G3TA I/O Solid-state Relays can be mounted.
- Conforms to UL and CSA standards.

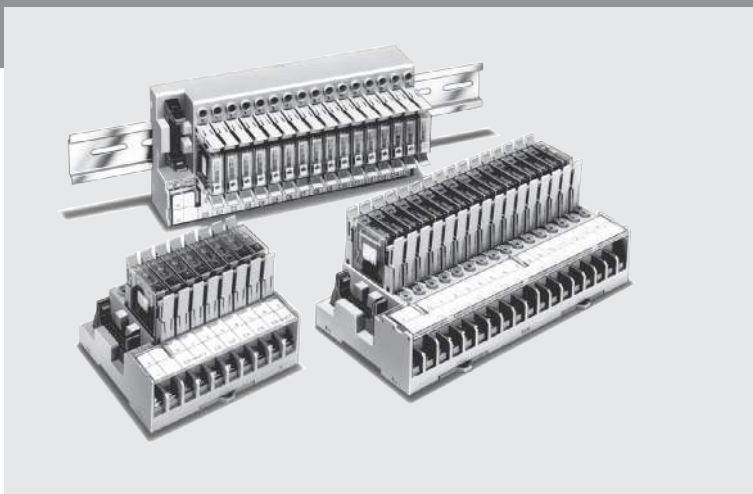

Ordering Information

I/O classification	I/O points	Internal I/O circuit common	Rated voltage	Model
Input	16	NPN compatible (- common)	12 V DC	G7TC-ID16*
			24 V DC	
			100/110 V DC	
			100/110 V AC	G7TC-IA16*
			200/220 V AC	
Output	16	NPN compatible (+ common)	12 V DC	G7TC-OC16
			24 V DC	
		PNP compatible (- common)	12 V DC	G7TC-OC16-1*
			24 V DC	
	8	NPN compatible (+ common)	12 V DC	G7TC-OC08*
			24 V DC	
		PNP compatible (+ common)	24 V DC	G7TC-OC08-1*
			PNP compatible (- common)	

* This is a non-standard model and requires a special order. Contact your OMRON representative for details on availability.

Specifications

Coil Ratings (Common to Input/Output per Relay)

Item	Rated voltage (V)	Rated current (mA)		Coil resistance (Ω)	Must operate of rated voltage	Must release	Maximum voltage	Power consumption	
		50 Hz	60 Hz					per Relay	per 16 Relays
AC	100/110	8.2	7/7.7	8,700	80% max.	30% min.	105%	0.7 VA	11 VA
	200/220	4.1	3.5/3.88	33,300					
DC	12	42		290	80% max.	10% min.	105%	0.5 W	8 W
	24	21		1,150					
	100/110	5		20,000					

- Note:**
- The rated current and coil resistance are measured at a coil temperature of +23°C with a tolerance of +15%/–20% for AC rated current and ±15% for coil resistance.
 - The operating characteristics are measured at a coil temperature of +23°C.
 - The value for maximum voltage is the maximum value within the allowable voltage fluctuation range for the relay coil's operating power supply. Continuous operation at this voltage is not within product specifications.
 - Approx. 4 mA flows into each LED indicator. To calculate the power supply capacity, add the current value of each LED indicator.

Contact Ratings (G7T I/O Relay)

Classification	For input		For output	
	Resistive load (cosφ=1)	Inductive load (cosφ=0.4 L/R=7 ms)	Resistive load (cosφ=1)	Inductive load (cosφ=0.4 L/R=7 ms)
Rated load	1 A at 24 V DC	0.5 A at 24 V DC	5 A at 24 V DC 2 A at 220 V AC	2 A at 24 V DC 1 A at 220 V AC
Rated carry current	1 A		5 A	
Max. switching voltage	250 V AC, 125 V DC			
Max. switching current	1 A	0.5 A	5 A	2 A
Min. permissible load (reference value) (See note.)	100 μA at 1 V		10 mA at 5 V	
Electrical life expectancy	10,000,000 operations (at 10 mA) 50,000 operations (at 1 A)	2,500,000 operations (at 10 mA) 20,000 operations (at 1 A)	1,000,000 operations (under rated load)	
Mechanical life expectancy	50,000,000 operations			

Note: The above values are for a switching frequency of 120 operations/min.

Characteristics

Model Item	G7TC-IA16 (Input, AC coil)	G7TC-ID16 (Input, DC coil)	G7TC-OC16 (-1) (output, DC coil)	G7TC-OC08(-1) (output, DC coil)
Contact form	SPST-NO × 16			SPST-NO × 8
Contact mechanism	Bifurcated crossbar contact		Single contact	
Contact material	Au cladding + Ag		AgInSn	
Contact resistance (See note 2.)	50 mΩ max.			
Must Operate time (See note 3.)	15 ms max.			
Release time (See note 3.)	15 ms max.			
Max. switching frequency	Mechanical limit	18,000 operations/hour		
	At rated load	1,800 operations/hour		
Insulation resistance	100 MΩ (at 500 V DC)			
Dielectric strength	Between coil and contact	2,000 V AC, 50/60 Hz for 1 minute		
	Between same polarity contacts	1,000 V AC, 50/60 Hz for 1 minute		
	Between paired connectors	250 V AC, 50/60 Hz for 1 minute		
Vibration resistance	10 to 55 to 10 Hz with 0.5-mm single amplitude (1.0-mm double amplitude)			
Shock resistance	200 m/s ²			
Noise immunity	Noise level: 1.5 kV; pulse width: 100 ns to 1 μs			
Rated voltage between positive and negative terminal blocks	Rated voltage of controller's (PLC or other) input circuit		12 V DC ±5% (See note 5.) 24 V DC ±5%	
Rated current between positive and negative terminal blocks	Input circuit current of controller (PLC or other) × number of ON points		12 V DC: 46 mA × number of ON points 24 V DC: 25 mA × number of ON points	
Cable length (See note 4.)	To controller	5 m max. (reference value)		
	To I/O devices	50 m max. (reference value, for 2-mm ² CVV cable)		Dependent on load
Ambient operating temperature	0 to 55°C			
Ambient operating humidity	35% to 85% (with no icing or condensation)			
Tightening torque for external connections	0.78 to 1.18 N·m			
Tensile strength	No damage when a tensile force of 49 N is applied in each direction. In the direction of the track, the tensile strength is 9.8 N min.			
I/O terminal tightening torque	Tightening strength: 0.98 N·m; Tensile strength 49 N for 1 minute			
LED color	Red	Green		
Case color	Transparent red	Transparent green	Transparent	
Coil surge absorber	Varistor	Diode (1 A, 400 V)		
Weight	Approx. 640 g	Approx. 630 g	Approx. 670 g	Approx. 350 g

- Note:**
- These are initial values.
 - Measurement condition: 1 A at 5 V DC.
 - Ambient temperature: 23°C.
 - Connecting cables up to 5 m are available as standard products. (See page 401.) For longer cables, enquire separately.
 - G7TC-OC08-01 is not available in 12 V DC type.

Accessories (Order Separately)

G79 Connecting Cables

Cable Type	Model
Cable with Loose Wire and Crimp Terminals	G79-Y□C
Cable with Loose Wires	G79-A□C
Cable with Three Connectors (1:3)	G79-□C-□-□
Cable with Two Connectors (1:2)	G79-□C-□
Cable with One Connector (1:1)	G79-□C

Note: See page 401 for more details.

G78-04 Shorting Bar

Use this piece to short-circuit adjacent terminals.
Max. current flow: 20 A

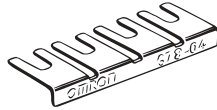

G77-S Output Short-Circuit Module

A G77-S Output Short-Circuit Module can be used to output directly without a relay. The G77-S Output Short-Circuit Module cannot be used for inputs.

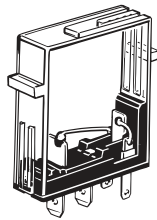

P7TF-05 Socket

The G7T (SPST-NO, SPST-NC, and SPDT types) and the G3TA I/O Relays can be mounted on the P7TF-05 Socket.

The P7TF-05 can be used for applications involving sequences that require slim relays, or to enable use of SPDT relays with the I/O Block. To use part of the I/O Block with SPDT specifications, insert an Output Short-Circuit Module into the I/O Block, and use the P7TF-05 Socket in combination with an SPDT Relay for the Module's output.

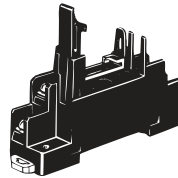

Specifications

Contact resistance	10 mΩ max. (measured at 5 V DC, 1 A)
Dielectric strength	2,000 V AC for 1 minute
Insulation resistance	100 MΩ (at 500 V)
Vibration resistance	10 to 55 to 10 Hz with 0.5-mm single amplitude (1.0-mm double amplitude)
Shock resistance	200 m/s ²
Ambient temperature	Operating: 0 to 55° C
Ambient humidity	35% to 85%
Weight	Approx. 28 g

P70 Indicator Module and Surge Suppressor

Remove the transparent style strip of the P7TF-05 socket and mount this module and it will function as an operation indicator and surge suppressor.

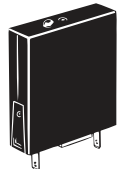

Ordering Information

Model	Applicable relay coil voltage	Remarks
For AC relay	P70A	100 (110) V AC 200 (220) V AC Varistor surge suppression
	P70D	
For DC relay	P70D	12/24 V DC Diode surge suppression

- Note:**
1. Order the indicator module suitable for the relay coil voltage.
 2. The indicator module for DC relays can be used with a 12-V or 24-V DC power supply.

Precautions

General

I/O Relays and I/O Block Bases can be combined as follows to form I/O Blocks:

	Combinations (See note.)	Block Base	I/O Relay	I/O SSR	
DC output	G7TC-OC16	P7TF-OS16	G7T-1112S	AC	G3TA-OA202SZ
	G7TC-OC16-1	P7TF-OS16-1			G3TA-OA202SL
	G7TC-OC08	P7TF-OS08		DC	G3TA-ODX02S
	G7TC-OC08-1	P7TF-OS08-1			G3TA-OD201S
DC input	G7TC-ID16	P7TF-IS16 (DC type)	G7T-1122S	DC	G3TA-IDZR02S (M)
AC input	G7TC-IA16	P7TF-IS16 (AC type)		AC	G3TA-IAZR02S

Note: The model numbers given under "Combinations" are for combinations with I/O Relays. To use I/O SSRs, either replace an I/O Relay with the SSR, or purchase an I/O Terminal (Block Base) and an I/O SSR (i.e., not the combined Unit).

- AC Input Relays/SSRs and DC Input Relays/SSRs cannot be used together in the same Terminal because of the specifications for coil surge suppression elements are different.
Furthermore, Relays/SSRs with different voltage specifications cannot be used together in the same Terminal because the specifications of operation indicator circuits are different. (For example, a 100-V AC Input Relay and a 200-V AC Input Relay, or a 12-V DC Output Relay and a 24-V DC Output Relay cannot be used in the same Terminal.)
- Only use I/O Terminals, I/O Relays, and I/O SSRs with the same specifications for rated voltage.

G79

I/O Block Connecting Cables

G79 Connecting Cables

Connecting Cables with Crimp Terminals (G79-Y□C)

This Cable is convenient for connecting I/O Blocks to devices equipped with screw terminals.

Length (L)	Model
1,000 mm	G79-Y100C*
1,500 mm	G79-Y150C*
2,000 mm	G79-Y200C*
3,000 mm	G79-Y300C*
5,000 mm	G79-Y500C*

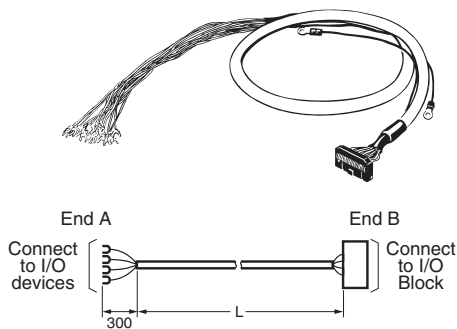

- Note:**
1. The power line capacity is 50 mA max. per I/O point. Also, always check the driver capacity and I/O relay power consumption when using an Output Block.
 2. The crimp terminals are labeled with the corresponding connector pin numbers in parentheses.
 3. Connect terminals 9 and 19 and terminals 10 and 20 together when using the G7TC-OC08.
 4. The wire gauge of the wires in the cable is 28 AWG (10/0.38).

Loose-wire Connecting Cables (G79A□C)

This Cable has loose wires at the device end.

Length (L)	Model
2,000 mm	G79-A200C*
5,000 mm	G79-A500C*

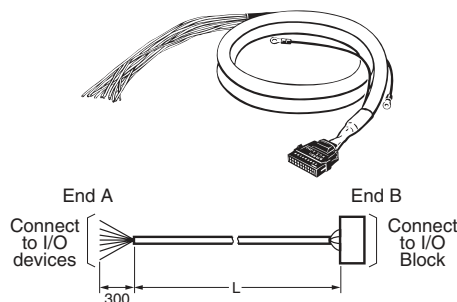

- Note:**
1. The wire gauge of the wires in the cable is 24 AWG (7/0.203).
 2. Connect terminals 9 and 19 and terminals 10 and 20 together when using the G7TC-OC08.

Connecting Cables with One Connector (G79-□C)

This Cable is convenient for connecting an I/O Block to a single device equipped with one connector socket.

Length (L)	Model
1,000 mm	G79-100C*
1,500 mm	G79-150C*
2,000 mm	G79-200C*
3,000 mm	G79-300C*
5,000 mm	G79-500C*

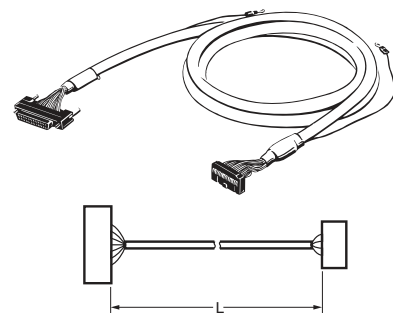

Connecting Cables with Two Connectors (G79-O□C-□ and G79-I□C-□)

Cables for both Output Blocks (for connection to SYSMAC I/O Units; tape color: red) and Input Blocks (for connection to SYSMAC I/O Units; tape color: yellow) are available.

Length		Cables for Input Blocks	Cables for Output Blocks
A	B		
1,000 mm	750 mm	G79-I100C-75*	G79-O100C-75*
1,500 mm	1,250 mm	G79-I150C-125*	G79-O150C-125*
2,000 mm	1,750 mm	G79-I200C-175*	G79-O200C-175*
3,000 mm	2,750 mm	G79-I300C-275*	G79-O300C-275*
5,000 mm	4,750 mm	G79-I500C-475*	G79-O500C-475*

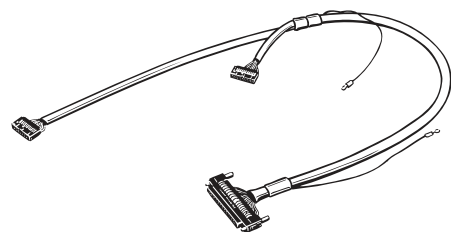

Note: The 32-point card-type connectors for the Input Block Cables and Output Block Cables have different pin arrangements.

* This is a non-standard model and requires a special order. Contact your OMRON representative for details on availability.

Connecting Cables for Mitsubishi PLCs

The following cables can be used to connect a Mitsubishi PLC (with a 32-point connector) to I/O Blocks.

Length		Model	Model
A	B		
1,000 mm	750 mm	G79-I100C-75-MN (See note.)	G79-O100C-75-MN
1,500 mm	1,250 mm	G79-I150C-125-MN (See note.)	G79-O150C-125-MN
2,000 mm	1,750 mm	G79-I200C-175-MN	G79-O200C-175-MN
3,000 mm	2,750 mm	G79-I300C-275-MN	G79-O300C-275-MN

These are all non-standard model and require a special order. Contact your OMRON representative for details on availability.

Note: 1. Applicable Mitsubishi PLC models
 Inputs: AX42, A1SX41, and A1SX42
 Outputs: AY42, A1SY41, and A1SY42

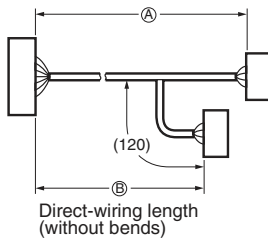

Connecting Cables with Three Connectors (G79-□C-□-□)

Length			Model
A	B	C	
1,500 mm	1,250 mm	1,000 mm	G79-150C-125-100
2,000 mm	1,750 mm	1,500 mm	G79-200C-175-150
3,000 mm	2,750 mm	2,500 mm	G79-300C-275-250

These are all non-standard model and require a special order. Contact your OMRON representative for details on availability.

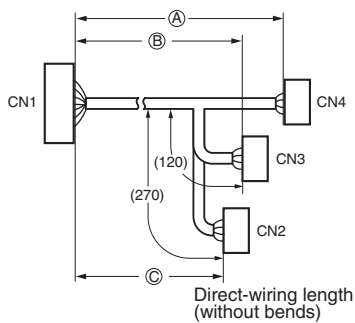
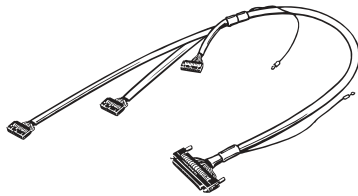

XW2

I/O terminal blocks and cables

Ideal for Reducing Wiring to PLCs and Other Equipment in the Control Panel

Connecting Components (PLC Units, Connector-Terminal Conversion Units, and Cables)

Use the XW2D for Connections to Controllers

CJ1 Basic I/O Units

CJ Basic I/O Units with 32-point connectors

- CJ1W-ID231 (Fujitsu Connector/Input Unit)
- CJ1W-OD231 (Fujitsu Connector/Output Unit)
- CJ1W-ID232 (MIL Connector/Input Unit)
- CJ1W-OD232/OD233 (MIL Connector/Output Unit)

CJ1M CPU Unit

- CJ1M-CPU22/CPU23 (MIL Connector/Built-in I/O)

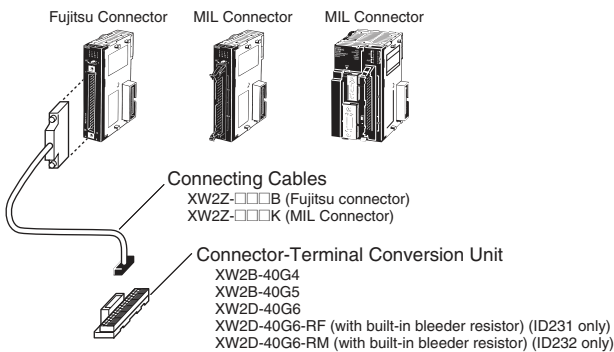

CJ Basic I/O Units with 64-point connectors

- CJ1W-ID261 (Fujitsu connector/Input Unit)
- CJ1W-OD261 (Fujitsu connector/Output Unit)
- CJ1W-MD261 (Fujitsu connector/I/O Unit)
- CJ1W-ID262 (MIL Connector/Input Unit)
- CJ1W-OD263 (MIL Connector/Output Unit)
- CJ1W-MD263 (MIL Connector/I/O Unit)
- CJ1W-MD563 (MIL Connector/I/O Unit)

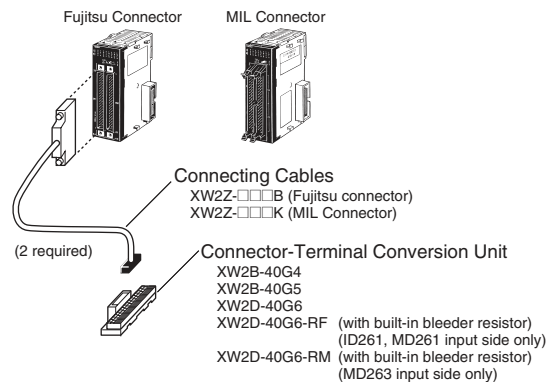

CJ Basic I/O Unit with 32-point Connectors

- CJ1W-ID231 (Fujitsu Connector/Input Unit)
- CJ1W-OD231 (Fujitsu Connector/Output Unit)
- CJ1W-ID232 (MIL Connector/Input Unit)
- CJ1W-OD232/OD233 (MIL Connector/Output Unit)

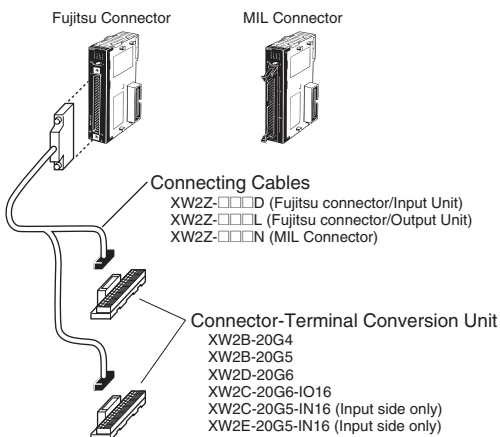

CJ Basic I/O Unit with 64-point Connectors

- CJ1W-ID261 (Fujitsu Connector/Input Unit)
- CJ1W-OD261 (Fujitsu Connector/Output Unit)
- CJ1W-MD261 (Fujitsu Connector/I/O Unit)
- CJ1W-ID262 (MIL Connector/Input Unit)
- CJ1W-OD263 (MIL Connector/Output Unit)
- CJ1W-MD263 (MIL Connector/I/O Unit)
- CJ1W-MD563 (MIL Connector/I/O Unit)

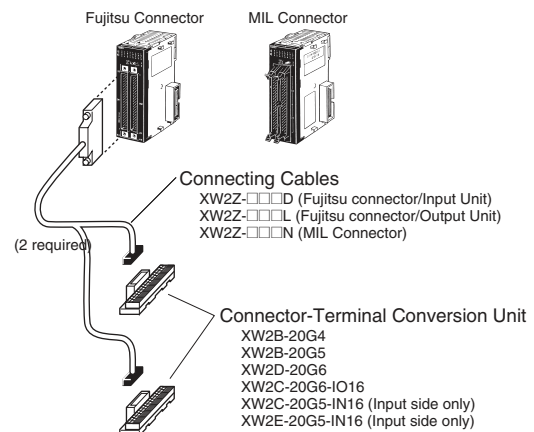

CJ Basic I/O Unit with 32-point Connectors
 CJ1W-MD231 (Fujitsu Connector/Input Unit)
 CJ1W-MD233 (MIL Connector/I/O Unit)

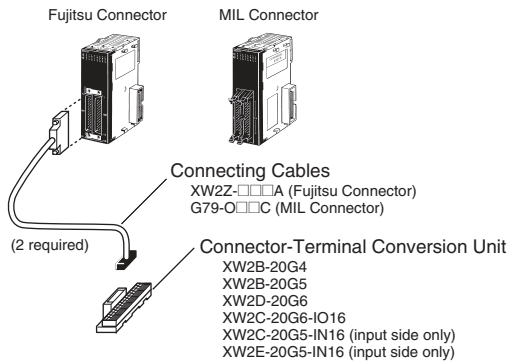

CS1 Basic I/O Units with 96-point and Two 48-point Connectors

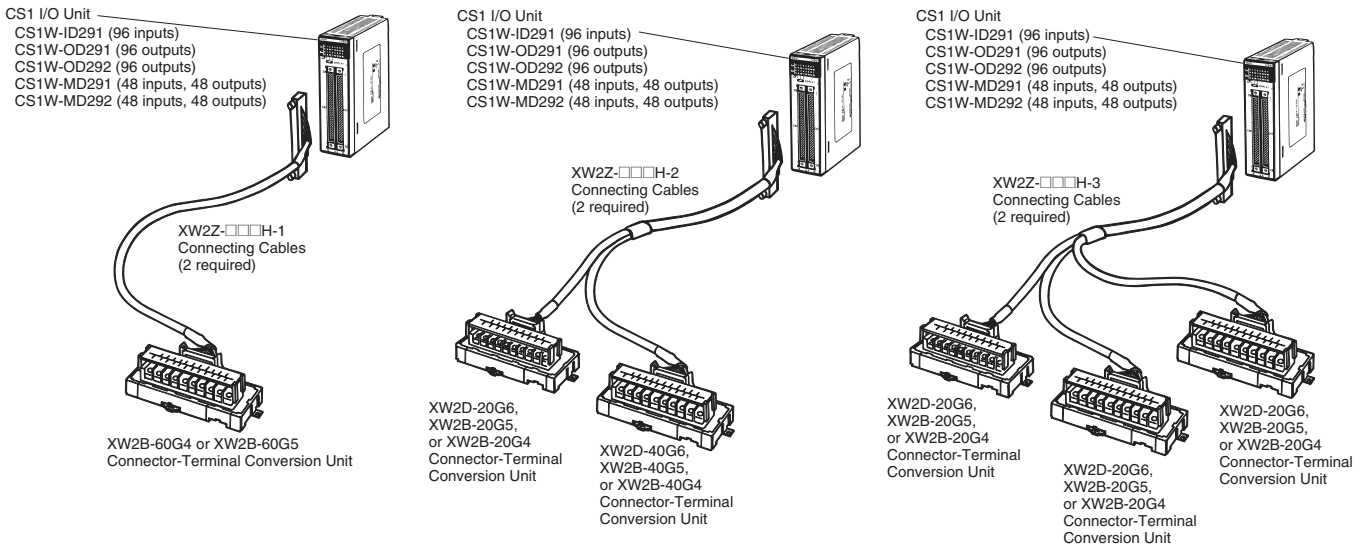

I/O Units with 32-point Connectors (Group-2) I/O Units with 64-point Connectors

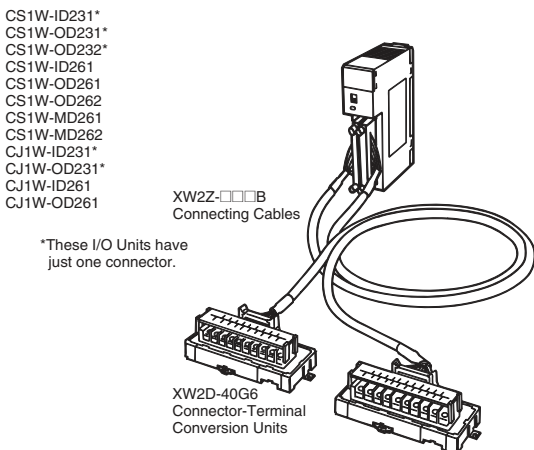

XW2B

I/O terminal block

Easily wire connectors to Terminal Blocks and Reduce Control Panel Wiring

- Can be mounted with screws or snapped onto DIN rail.
- Standard models are available with MIL flat cable connectors and multipole rectangular connectors.
- Terminal Blocks are available with M2.5 or M3.5 screws.
- Cables are available for OMRON PLC connectors.



Ordering Information

Poles	Model
20	XW2B-20G5
34	XW2B-34G5*
40	XW2B-40G5
50	XW2B-50G5*
60	XW2B-60G5*
20	XW2B-20G4
34	XW2B-34G4*
40	XW2B-40G4
50	XW2B-50G4*
60	XW2B-60G4*

* This is a non-standard model and requires a special order. Contact your OMRON representative for details on availability.

Specifications

Ratings/Characteristics

Rated current	1 A
Rated voltage	125 V AC
Insulation resistance	100 MΩ min. (at 500 V DC)
Dielectric strength	500 V AC for 1 min (with a leakage current of 1 mA max.)
Ambient temperature	Operating: -25 to 80 °C

Dimensions

Note: All dimensions are in mm.

XW2B-□□G5
(M3.5 Screws)

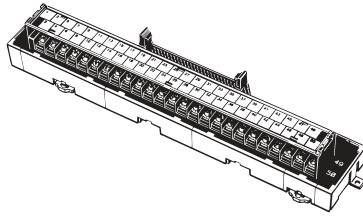

XW2B-□□G4
(M2.5 Screws)

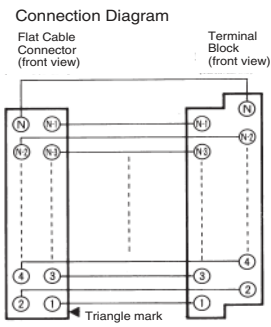
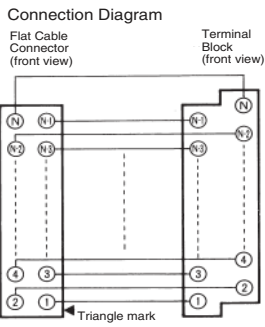
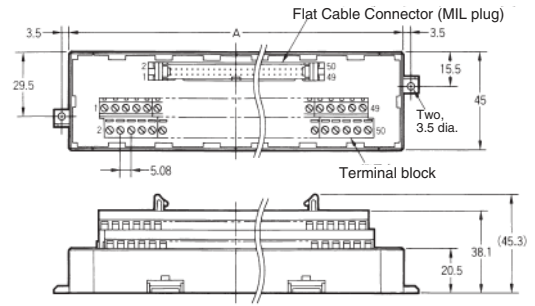
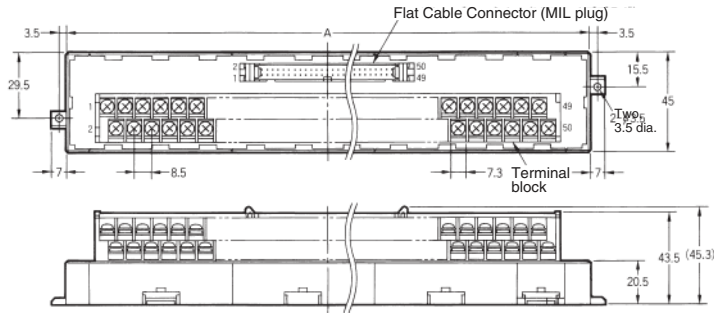
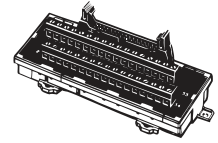

Dimensions

Model	Poles	Dimension A (mm)
XW2B-20G5	20	112.5
XW2B-34G5	34	180.0
XW2B-40G5	40	202.5
XW2B-50G5	50	247.5
XW2B-60G5	60	292.5

Dimensions

Model	Poles	Dimension A (mm)
XW2B-20G4	20	67.5
XW2B-34G4	34	112.5
XW2B-40G4	40	135.0
XW2B-50G4	50	157.5
XW2B-60G4	60	180.0

XW2B

Servo I/O terminal block

Combines Connectors and the Terminal Block to Reduce Wiring between Servo Drivers and Position Control Units

- Allows simple terminal block wiring of control signals between a Servo Driver and a Position Control Unit or CQM1 PLC (with built-in pulse I/O function).
- No need to solder connections; all you need is a screwdriver.
- Special cables are available to connect various Units.
- Only a 24-V DC power supply is required for control signals.
- Space-saving terminal blocks use M3.0 screws.
- Can be mounted with screws or snapped onto DIN rail.

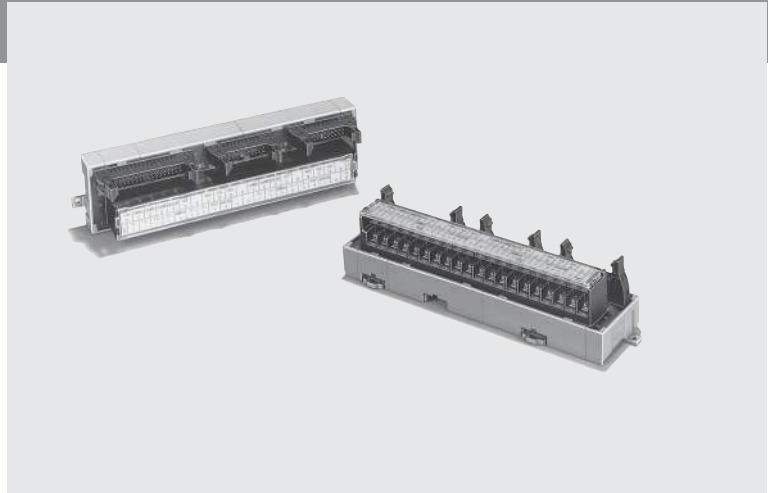

Ordering Information

Compatible Servo Drivers	Compatible Position Control Units	Model number
SMARTSTEP Series: R7D-AP□□□ W Series: R88D-WT□□□□ U Series: R88D-UP□□□ R88D-UT□□□ R88D-UEP□□□ M Series: R88D-MT□□□ H Series: R88D-H□□□	NC Units (Communications functions are not supported.) CS1W-NC113/133CJ1W-NC113/133 C200HW-NC113 C200H-NC112 3F88M-DRT141	XW2B-20J6-1B
	NC Units (Communications functions are not supported.) CS1W-NC213/233/413/433 CJ1W-NC213/233/413/433 C200HW-NC213/413 C200H-NC211	XW2B-40J6-2B
	Other Units (Communications functions are not supported.) CS1W-HCP22 CQM1H-PLB21 CQM1-CPU43-V1	XW2B-20J6-3B
	NC Units (Communications functions are supported.) CS1W-NC213/233/413/433 CJ1W-NC213/233/413/433	XW2B-40J6-4A
	CPU units (Communications functions are not supported) CJ1M-CPU22/23	XW2B-20J6-8A (one axis)
	CPU units (Communications functions are not supported) CJ1M-CPU22/23	WX2B-20J6-9A (two axis)

Connection Example

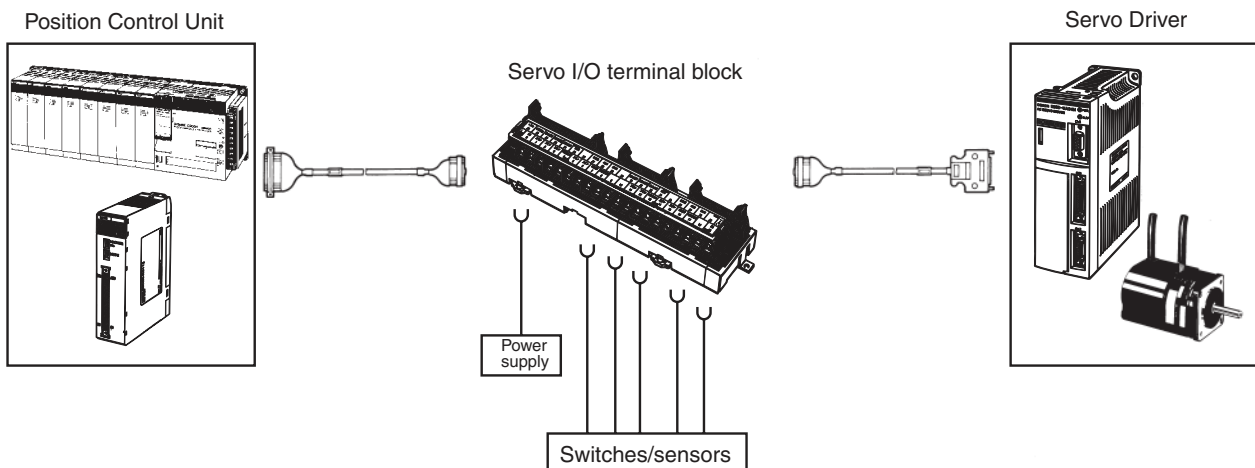

- Simple terminal block wiring of control signals between Servo Driver and Position Control Unit.

XW2C

Input terminal block

Equipped with Power Supply Common and Operation Indicators and Reduces Control Panel Wiring to Input Devices

- Equipped with a power supply common for input devices.
- Operation indicators show each I/O signal's ON/OFF status at a glance.
- Can be mounted on DIN rail or screw-mounted.
- Compatible Connecting Cables are available (sold separately.)

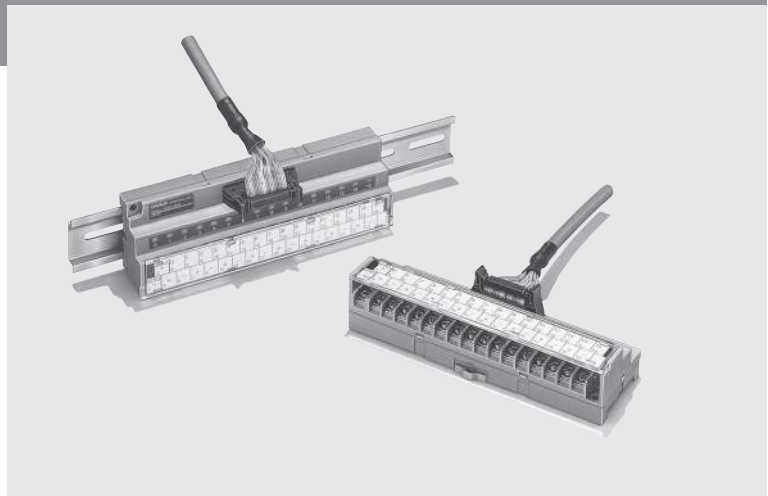

Ordering Information

Points	Internal I/O circuit common	Model
16 inputs	NPN compatible (+ common)	XW2C-20G5-IN16

This is a non-standard model and requires a special order. Contact your OMRON representative for details on availability.

Specifications

Ratings/Characteristics

Rated current	1 A/common
Rated voltage	12 to 24 V DC
Number of circuits	16 points
Input display	LED indicators (orange)
Power supply voltage range	12 to 24 V DC $\pm 5\%$
LED indicator current	10 mA/input max. at 24 V DC
Insulation resistance	50 M Ω min. (at 500 V DC)
Dielectric strength	500 V AC for 1 min
Ambient temperature	Operating: 0 to 55 °C

Dimensions

Note: All dimensions are in mm.

XW2C-20G5-IN16

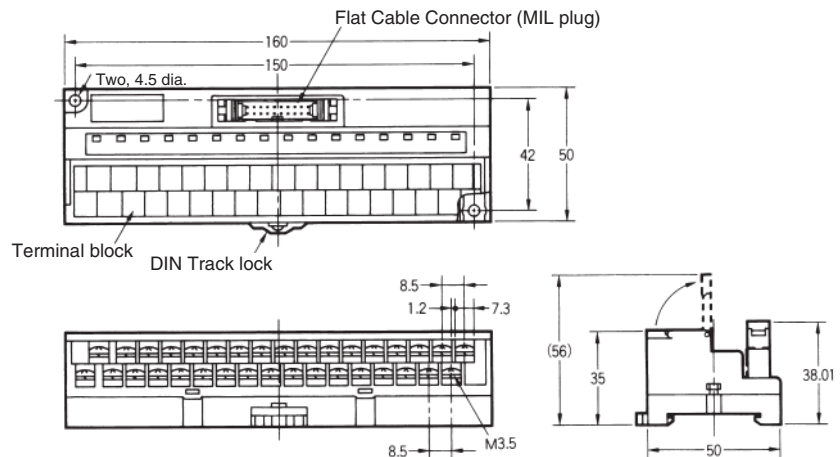
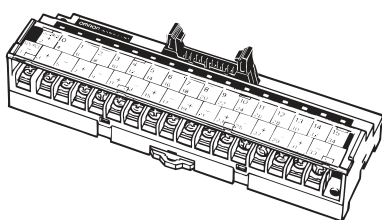

XW2D

Slim Input terminal block

Introducing the XW2D Series, a Slim Version of the I/O terminal block

- Required mounting area reduced by 35% (compared to OMRON's 40-pole XW2B Unit), allowing for smaller control panels and automatic equipment.
- Terminal screw mechanism prevents lost terminal screws.
- Use either round or forked crimp terminals.
- Mount via DIN rail or screws. Unique DIN rail lock to mount or remove Units from DIN rail while open.
- Terminal cover can be fixed in the open position.
- Easy-count terminal numbers with different colors every five terminals.

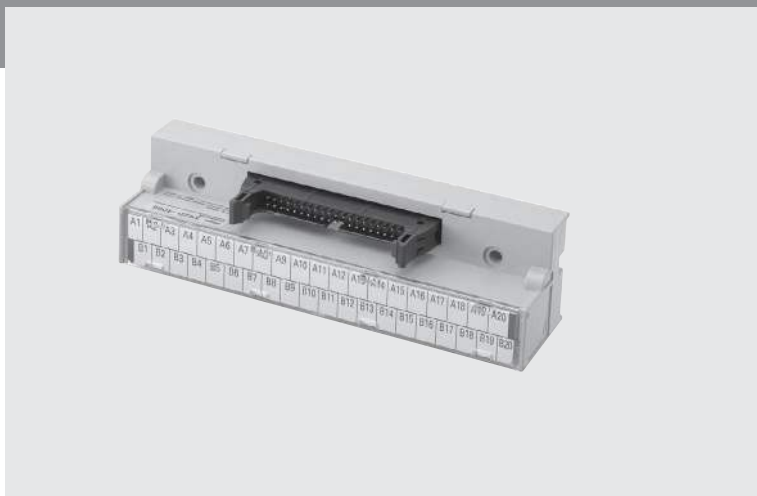

Ordering Information

Mounted connector	Poles	Model	Dimension A	Dimension B	Mounted connector model	Cable connector model
MIL, XG4A	20	XW2D-20G6	79	57	XG4A-2031	XG4M-2030-T
	34	XW2D-34G6*	128	100	XG4A-3431	XG4M-3430-T
		XW2D-40G6	149	110	XG4A-4031	XG4M-4030-T
		XW2D-40G6-RF* (See note 1.)	149	110	XG4A-4031	XG4M-4030-T
	50	XW2D-50G6*	184	144	XG4A-5031	XG4M-5030-T
MIL, XG4C	20	XW2D-20C6*	79	57	XG4C-2031	XG4M-2030-U
	34	XW2D-34C6*	128	100	XG4C-3431	XG4M-3430-U
	40	XW2D-40C6*	149	110	XG4C-4031	XG4M-4030-U
	50	XW2D-50C6*	184	144	XG4C-5031	XG4M-5030-U
MR Socket (See note 3.)	20	XW2D-20X6*	79	57	MR-20RFD2	MR-20M
	34	XW2D-34X6*	128	100	MR-34RFD2	MR-34M
	50	XW2D-50X6*	184	144	MR-50RFD2	MR-50M
MR Plug (See note 3.)	20	XW2D-20Y6*	79	57	MR-20RMD2	MR-20F
	34	XW2D-34Y6*	128	100	MR-34RMD2	MR-34F
	50	XW2D-50Y6*	184	144	MR-50RMD2	MR-50F

- Note:**
1. Has a built-in bleeder resistor and is for the CJ1W-ID231/ID261. External dimensions are the same as the XW2D-40G6.
 2. Has a built-in bleeder resistor and is for the CJ1W-ID232. External dimensions are the same as the XW2D-40G6.
 3. The MR Connectors are manufactured by Honda Tsushin Kogyo Co., Ltd.

Specifications

Ratings /Characteristics

Rated current	1 A
Rated voltage	125 V AC, 24 V DC
Insulation resistance	100 MΩ max. (at 500 V DC)
Dielectric strength	500 V AC for 1 min (with a leakage current of 1 mA max.)
Ambient temperature	Operating: 0 to 55 °C

Dimensions

XW2D-□□G6 with XG4A MIL Connector

Note: In the 20-pole models, there is just one DIN rail lock located at the bottom-center of the Unit.

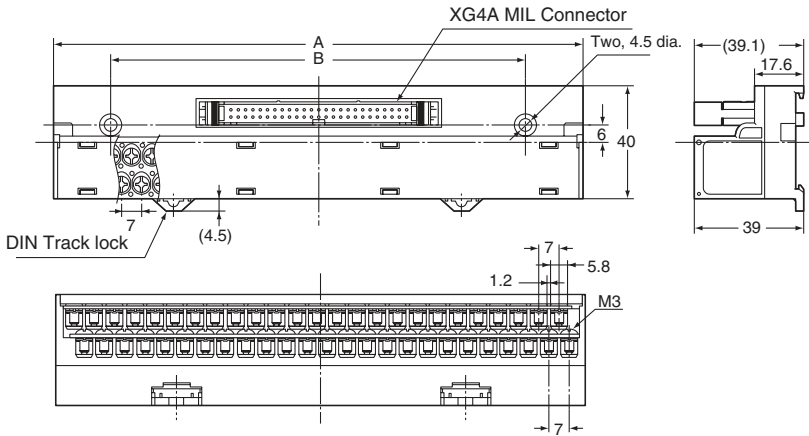

Connection Diagram (50-pole model)

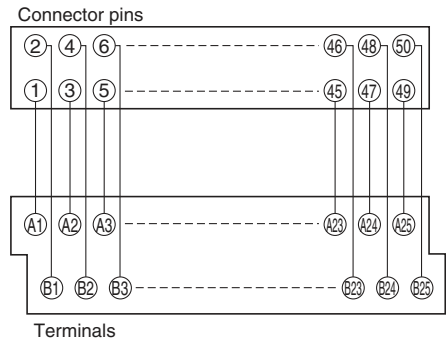

Note: The connector's odd-numbered poles connect to the "A" terminals and the connector's even-numbered poles connect to the "B" terminals.

XW2D-□□C6 with XG4C MIL Connector

Note: In the 20-pole models, there is just one DIN rail lock located at the bottom-center of the Unit.

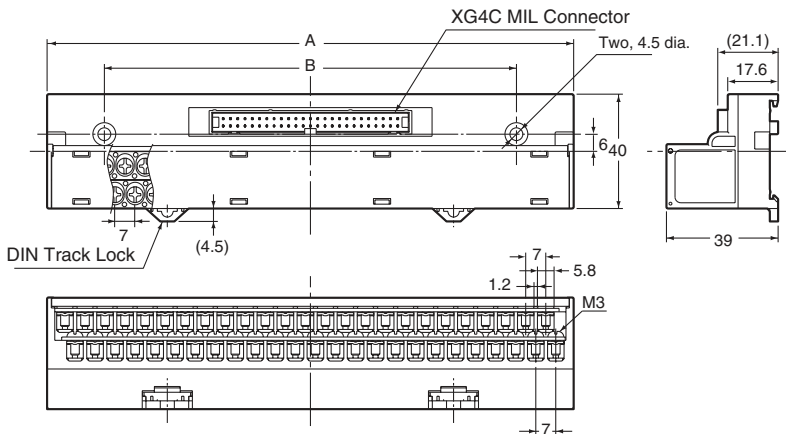

Connection Diagram (50-pole model)

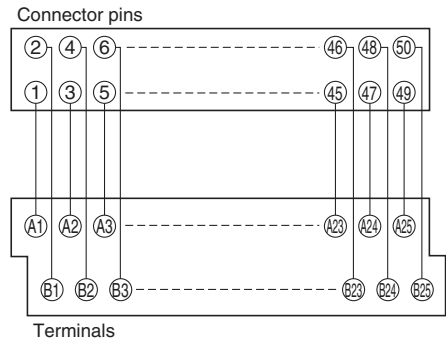

Note: The connector's odd-numbered poles connect to the "A" terminals and the connector's even-numbered poles connect to the "B" terminals.

XW2D-□□X6 with MR Socket Connector

Note: In the 20-pole models, there is just one DIN rail lock located at the bottom-center of the Unit.

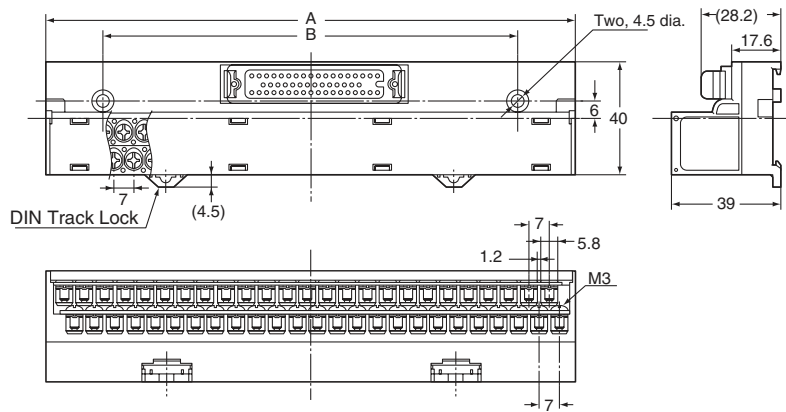

Connection Diagram (50-pole model)

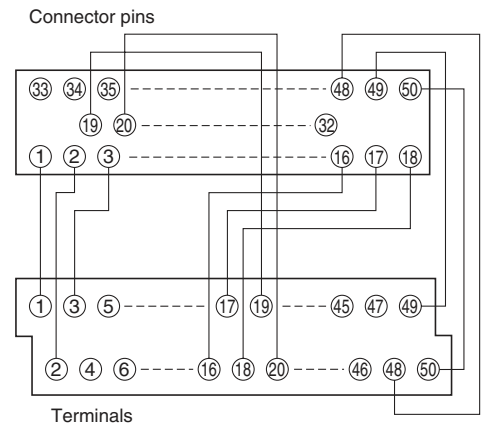

Note: The connector's poles connect to the MR socket terminals with the same number.

XW2D-□□Y6 with MR Plug Connector

Note: In the 20-pole models, there is just one DIN rail lock located at the bottom-center of the Unit.

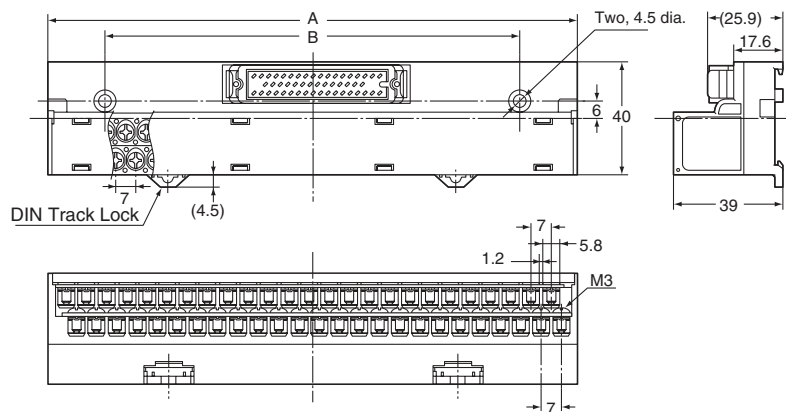

Connection Diagram (50-pole model)

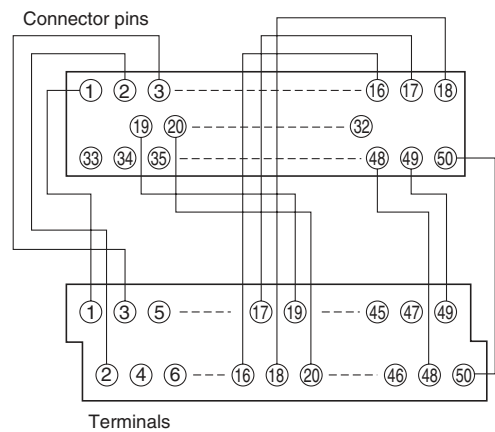

Note: The pin numbers on the connector correspond directly to the terminal numbers on the terminal block.

XW2Z

Connecting Cables for I/O terminal blocks

• Refer to page 416 for connection details.

XW2Z-□□□A Cables for PLC Units with 32-point Connectors

Ordering Information

XW2Z-□□□A

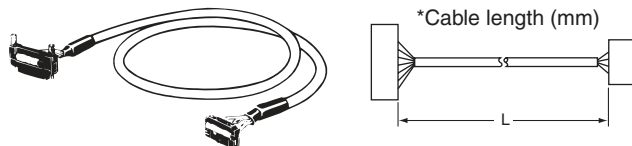

*Cable length L (mm)	Model
500 mm	XW2Z-050A
1,000 mm	XW2Z-100A
1,500 mm	XW2Z-150A*
2,000 mm	XW2Z-200A
3,000 mm	XW2Z-300A*
5,000 mm	XW2Z-500A*

XW2Z-□□□AU (See note.)

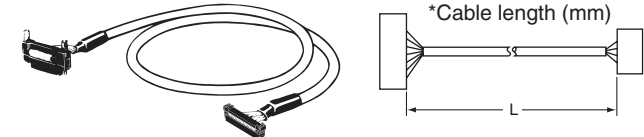

*Cable length L (mm)	Model
500 mm	XW2Z-050AU*
1,000 mm	XW2Z-100AU*
1,500 mm	XW2Z-150AU*
2,000 mm	XW2Z-200AU*
3,000 mm	XW2Z-300AU*
5,000 mm	XW2Z-500AU*

XW2Z-□□□B Cables for Group-2 PLC I/O Units with 32-point Connectors and PLC I/O Units with 64-point Connectors

XW2Z-□□□B

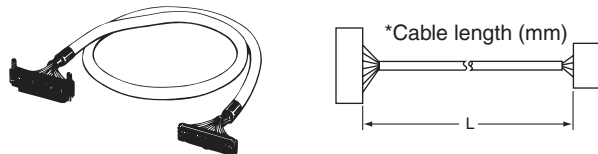

Wiring	*Cable length L (mm)	Model
Normal wiring	500 mm	XW2Z-050B
	1,000 mm	XW2Z-100B
	1,500 mm	XW2Z-150B*
	2,000 mm	XW2Z-200B
	3,000 mm	XW2Z-300B
	5,000 mm	XW2Z-500B

XW2Z-□□□BU (See note.)



Wiring	*Cable length L (mm)	Model
Normal wiring	500 mm	XW2Z-050BU*
	1,000 mm	XW2Z-100BU*
	1,500 mm	XW2Z-150BU*
	2,000 mm	XW2Z-200BU*
	3,000 mm	XW2Z-300BU*
	5,000 mm	XW2Z-500BU*

XW2Z-□□□D Cables for Group-2 PLC Input Units with 32-point Connectors and PLC Input Units with 64-point Connectors

XW2Z-□□□D

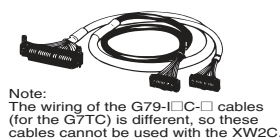

Note:
The wiring of the G79-□□C-□ cables (for the G7TC) is different, so these cables cannot be used with the XW2Z.

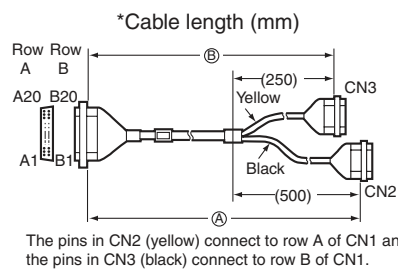

The pins in CN2 (yellow) connect to row A of CN1 and the pins in CN3 (black) connect to row B of CN1.

*Cable lengths (mm)		Model
A	B	
1,000 mm	750 mm	XW2Z-100D*
1,500 mm	1,250 mm	XW2Z-150D*
2,000 mm	1,750 mm	XW2Z-200D*
3,000 mm	2,750 mm	XW2Z-300D*
5,000 mm	4,750 mm	XW2Z-500D*

* This is a non-standard model and requires a special order. Contact your OMRON representative for details on availability.

XW2Z-□□□F Cables with Crimp Terminals (20 poles)

XW2Z-□□□F

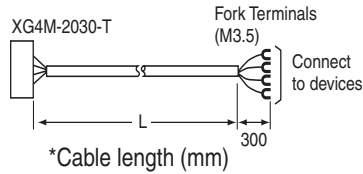
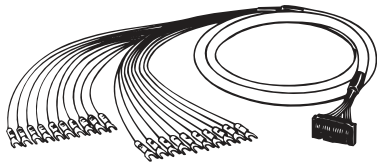

*Cable length L (mm)	Model
1,000 mm	XW2Z-100F
1,500 mm	XW2Z-150F
2,000 mm	XW2Z-200F
3,000 mm	XW2Z-300F
5,000 mm	XW2Z-500F

These are all non-standard model and require a special order. Contact your OMRON representative for details on availability.

XW2Z-□□□L Cables for Group-2 PLC Output Units with 32-point Connectors and PLC Output Units with 64-point Connectors

XW2Z-□□□L

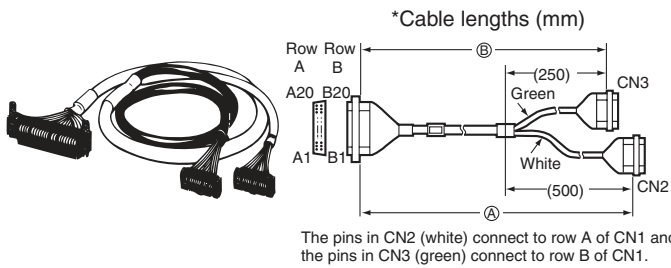

*Cable lengths (mm)		Model
A	B	
1,000 mm	750 mm	XW2Z-100L
1,500 mm	1,250 mm	XW2Z-150L
2,000 mm	1,750 mm	XW2Z-200L
3,000 mm	2,750 mm	XW2Z-300L
5,000 mm	4,750 mm	XW2Z-500L

These are all non-standard model and require a special order. Contact your OMRON representative for details on availability.

XW2Z-□□□H Cables for PLC I/O Units with 96-point Connectors

XW2Z-□□□H-1

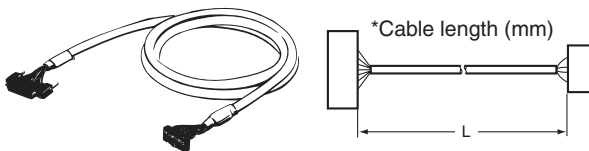

Cable length (mm)	Model
500 mm	XW2Z-050H-1
1,000 mm	XW2Z-100H-1
1,500 mm	XW2Z-150H-1
2,000 mm	XW2Z-200H-1
3,000 mm	XW2Z-300H-1
5,000 mm	XW2Z-500H-1
7,000 mm	XW2Z-700H-1
10,000 mm	XW2Z-010H-1

These are all non-standard model and require a special order. Contact your OMRON representative for details on availability.

XW2Z-□□□H-2

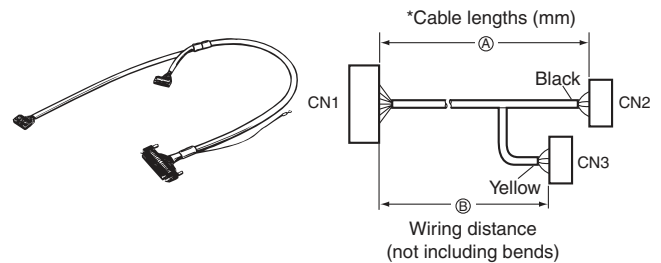

*Cable lengths (mm)		Model
A	B	
1,000 mm	750 mm	XW2Z-100H-2
1,500 mm	1,250 mm	XW2Z-150H-2
2,000 mm	1,750 mm	XW2Z-200H-2
3,000 mm	2,750 mm	XW2Z-300H-2
5,000 mm	4,750 mm	XW2Z-500H-2
10,000 mm	9,750 mm	XW2Z-010H-2

These are all non-standard model and require a special order. Contact your OMRON representative for details on availability.

XW2Z-□□□H-3

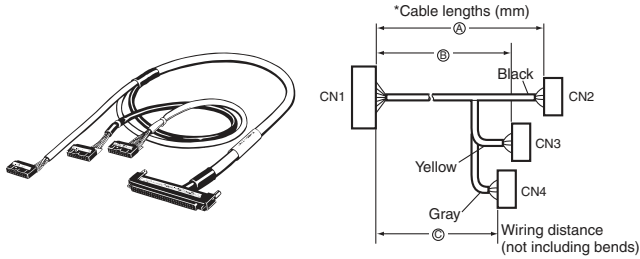

Cable lengths (mm)			Model
A	B	C	
1,000 mm	750 mm	1,000 mm	XW2Z-100H-3
1,500 mm	1,250 mm	1,500 mm	XW2Z-150H-3
2,000 mm	1,750 mm	2,000 mm	XW2Z-200H-3
3,000 mm	2,750 mm	3,000 mm	XW2Z-300H-3
5,000 mm	4,750 mm	5,000 mm	XW2Z-500H-3
10,000 mm	9,750 mm	10,000 mm	XW2Z-010H-3

These are all non-standard model and require a special order. Contact your OMRON representative for details on availability.

XW2Z-□□□K/N Cables for PLC I/O Units with 32-point MIL Connectors

XW2Z-□□□K

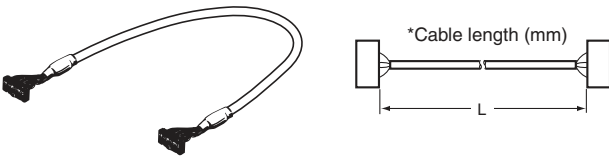

Cable length (mm)	Model (See note.)
1,000 mm	XW2Z-100K
1,500 mm	XW2Z-150K*
2,000 mm	XW2Z-200K
3,000 mm	XW2Z-300K*
5,000 mm	XW2Z-500K*

* This is a non-standard model and requires a special order. Contact your OMRON representative for details on availability.

XW2Z-□□□N

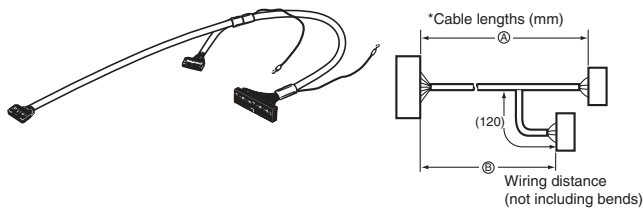

Cable lengths (mm)		Model
A	B	
1,000 mm	750 mm	XW2Z-100N
1,500 mm	1,250 mm	XW2Z-150N
2,000 mm	1,750 mm	XW2Z-200N
3,000 mm	2,750 mm	XW2Z-300N
5,000 mm	4,750 mm	XW2Z-500N

These are all non-standard model and require a special order. Contact your OMRON representative for details on availability.

XW2Z

Host Link Cables

PLC-compatible RS-232C Cables Ideal for Host Link Connections between a PLC and Host Computer or other Device

Ordering Information

SYSMAC PLC end	XW2Z Host Link Cable (PLC-compatible RS-232C cable)			Host device end																																								
	Wiring configuration	Cable length L (See note 1.)	Model number																																									
CS1□-CPU□□ CJ1□-CPU□□ CPM2A-CPU□□	<p>9-pin D-Sub Plug 9-pin D-Sub Socket</p> <table border="1"> <tr><th colspan="2">PLC end</th><th colspan="2">Host end</th></tr> <tr><td>Connector hood FG</td><td>1</td><td>1</td><td>---</td></tr> <tr><td>SD</td><td>2</td><td>2</td><td>RD</td></tr> <tr><td>RD</td><td>3</td><td>3</td><td>SD</td></tr> <tr><td>RS</td><td>4</td><td>4</td><td>ER</td></tr> <tr><td>CS</td><td>5</td><td>5</td><td>SG</td></tr> <tr><td>---</td><td>6</td><td>6</td><td>DR</td></tr> <tr><td>---</td><td>7</td><td>7</td><td>RS</td></tr> <tr><td>---</td><td>8</td><td>8</td><td>CS</td></tr> <tr><td>SG</td><td>9</td><td>9</td><td>---</td></tr> </table>	PLC end		Host end		Connector hood FG	1	1	---	SD	2	2	RD	RD	3	3	SD	RS	4	4	ER	CS	5	5	SG	---	6	6	DR	---	7	7	RS	---	8	8	CS	SG	9	9	---	2 m 5 m	XW2Z-200S-V XW2Z-500S-V*	Personal Computer
	PLC end		Host end																																									
Connector hood FG	1	1	---																																									
SD	2	2	RD																																									
RD	3	3	SD																																									
RS	4	4	ER																																									
CS	5	5	SG																																									
---	6	6	DR																																									
---	7	7	RS																																									
---	8	8	CS																																									
SG	9	9	---																																									
<p>9-pin D-Sub Plug 9-pin D-Sub Socket</p> <table border="1"> <tr><th colspan="2">PLC end</th><th colspan="2">Host end</th></tr> <tr><td>Connector hood FG</td><td>1</td><td>1</td><td>---</td></tr> <tr><td>SD</td><td>2</td><td>2</td><td>RD</td></tr> <tr><td>RD</td><td>3</td><td>3</td><td>SD</td></tr> <tr><td>RS</td><td>4</td><td>4</td><td>ER</td></tr> <tr><td>CS</td><td>5</td><td>5</td><td>SG</td></tr> <tr><td>---</td><td>6</td><td>6</td><td>DR</td></tr> <tr><td>DR</td><td>7</td><td>7</td><td>RS</td></tr> <tr><td>ER</td><td>8</td><td>8</td><td>CS</td></tr> <tr><td>SG</td><td>9</td><td>9</td><td>---</td></tr> </table> <p>ESD-preventive connectors are used.</p>	PLC end		Host end		Connector hood FG	1	1	---	SD	2	2	RD	RD	3	3	SD	RS	4	4	ER	CS	5	5	SG	---	6	6	DR	DR	7	7	RS	ER	8	8	CS	SG	9	9	---	2 m 5 m	XW2Z-200S-CV* XW2Z-500S-CV*		
PLC end		Host end																																										
Connector hood FG	1	1	---																																									
SD	2	2	RD																																									
RD	3	3	SD																																									
RS	4	4	ER																																									
CS	5	5	SG																																									
---	6	6	DR																																									
DR	7	7	RS																																									
ER	8	8	CS																																									
SG	9	9	---																																									
CS1□-CPU□□ CJ1□-CPU□□ CPM2A-CPU□□	<p>9-pin D-Sub Plug 9-pin D-Sub Plug</p> <table border="1"> <tr><th colspan="2">PLC end</th><th colspan="2">Host end</th></tr> <tr><td>Connector hood FG</td><td>1</td><td>1</td><td>---</td></tr> <tr><td>SD</td><td>2</td><td>2</td><td>SD</td></tr> <tr><td>RD</td><td>3</td><td>3</td><td>RD</td></tr> <tr><td>RS</td><td>4</td><td>4</td><td>RS</td></tr> <tr><td>CS</td><td>5</td><td>5</td><td>CS</td></tr> <tr><td>SG</td><td>9</td><td>9</td><td>SG</td></tr> </table>	PLC end		Host end		Connector hood FG	1	1	---	SD	2	2	SD	RD	3	3	RD	RS	4	4	RS	CS	5	5	CS	SG	9	9	SG	2 m 5 m	XW2Z-200T XW2Z-500T	Programmable Terminal: NT20S, NT600S, NT620S, NT620C, NT30, or NT30C NT31, or NT31C, NT631, or NT 631 C, NS-series												
PLC end		Host end																																										
Connector hood FG	1	1	---																																									
SD	2	2	SD																																									
RD	3	3	RD																																									
RS	4	4	RS																																									
CS	5	5	CS																																									
SG	9	9	SG																																									

Note: 1. The cable length does not include the connectors, as shown in the following diagram.

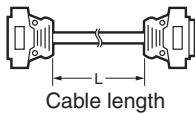

* This is a non-standard model and requires a special order. Contact your OMRON representative for details on availability.

I/O Connecting Cable Selection guide

Connecting to CS1 I/O Units

I/O Unit model	Connector-Terminal Conversion Unit or I/O Block model	Connecting Cable				Page		
		Branching	Length (m)	Model				
CS1W-ID291 (48 points x 2)	XW2B-60G5 XW2B-60G4	1:1	0.5	XW2Z-050H-1	413			
			1	XW2Z-100H-1				
			1.5	XW2Z-150H-1				
			2	XW2Z-200H-1				
			3	XW2Z-300H-1				
			5	XW2Z-500H-1				
			7	XW2Z-700H-1				
			10	XW2Z-010H-1				
			XW2D-20G6 + XW2D-40G6 XW2B-20G5 + XW2B-40G5 XW2B-20G4 + XW2B-40G4	1:2		1	XW2Z-100H-2	413
						1.5	XW2Z-150H-2	
	2	XW2Z-200H-2						
	3	XW2Z-300H-2						
	5	XW2Z-500H-2						
	10	XW2Z-010H-2						
	XW2D-20G6 (3 Units) XW2B-20G5 (3 Units) XW2B-20G4 (3 Units)	1:3			1	XW2Z-100H-3	413	
					1.5	XW2Z-150H-3		
					2	XW2Z-200H-3		
					3	XW2Z-300H-3		
			5	XW2Z-500H-3				
			10	XW2Z-010H-3				
G7TC-IA16/ID16	1:3	1.5	G79-150C-125-100	402				
		2	G79-200C-175-150					
		3	G79-300C-275-250					
CS1W-OD291 (48 points 2)	XW2B-60G5 XW2B-60G4	1:1	0.5	XW2Z-050H-1	413			
			1	XW2Z-100H-1				
			1.5	XW2Z-150H-1				
			2	XW2Z-200H-1				
			3	XW2Z-300H-1				
			5	XW2Z-500H-1				
			7	XW2Z-700H-1				
			10	XW2Z-010H-1				
			XW2D-20G6 + XW2D-40G6 XW2B-20G5 + XW2B-40G5 XW2B-20G4 + XW2B-40G4	1:2		1	XW2Z-100H-2	413
						1.5	XW2Z-150H-2	
	2	XW2Z-200H-2						
	3	XW2Z-300H-2						
	5	XW2Z-500H-2						
	10	XW2Z-010H-2						
	XW2D-20G6 (3 Units) XW2B-20G5 (3 Units) XW2B-20G4 (3 Units)	1:3			1	XW2Z-100H-3	413	
					1.5	XW2Z-150H-3		
					2	XW2Z-200H-3		
					3	XW2Z-300H-3		
			5	XW2Z-500H-3				
			10	XW2Z-010H-3				
G7TC-OC16/08 G70D-SOC16/ VSOC16 G70A-ZOC16-3	1:3	1.5	G79-150C-125-100	402				
		2	G79-200C-175-150					
		3	G79-300C-275-250					

I/O Unit model	Connector-Terminal Conversion Unit or I/O Block model	Connecting Cable				Page		
		Branching	Length (m)	Model				
CS1W-OD292 (48 points 2)	XW2B-60G5 XW2B-60G4	1:1	0.5	XW2Z-050H-1	413			
			1	XW2Z-100H-1				
			1.5	XW2Z-150H-1				
			2	XW2Z-200H-1				
			3	XW2Z-300H-1				
			5	XW2Z-500H-1				
			7	XW2Z-700H-1				
			10	XW2Z-010H-1				
			XW2D-20G6 + XW2D-40G6 XW2B-20G5 + XW2B-40G5 XW2B-20G4 + XW2B-40G4	1:2		1	XW2Z-100H-2	413
						1.5	XW2Z-150H-2	
	2	XW2Z-200H-2						
	3	XW2Z-300H-2						
	5	XW2Z-500H-2						
	10	XW2Z-010H-2						
	XW2D-20G6 (3 Units) XW2B-20G5 (3 Units) XW2B-20G4 (3 Units)	1:3			1	XW2Z-100H-3	413	
					1.5	XW2Z-150H-3		
					2	XW2Z-200H-3		
					3	XW2Z-300H-3		
			5	XW2Z-500H-3				
			10	XW2Z-010H-3				
G7TC-OC16-1	1:3	1.5	G79-150C-125-100	402				
		2	G79-200C-175-150					
		3	G79-300C-275-250					
CS1W-MD291 (48 inputs) (48 outputs)	XW2B-60G5 XW2B-60G4	1:1	0.5	XW2Z-050H-1	413			
			1	XW2Z-100H-1				
			1.5	XW2Z-150H-1				
			2	XW2Z-200H-1				
			3	XW2Z-300H-1				
			5	XW2Z-500H-1				
			7	XW2Z-700H-1				
			10	XW2Z-010H-1				
			XW2D-20G6 + XW2D-40G6 XW2B-20G5 + XW2B-40G5 XW2B-20G4 + XW2B-40G4	1:2		1	XW2Z-100H-2	413
						1.5	XW2Z-150H-2	
	2	XW2Z-200H-2						
	3	XW2Z-300H-2						
	5	XW2Z-500H-2						
	10	XW2Z-010H-2						
	XW2D-20G6 (3 Units) XW2B-20G5 (3 Units) XW2B-20G4 (3 Units)	1:3			1	XW2Z-100H-3	413	
					1.5	XW2Z-150H-3		
					2	XW2Z-200H-3		
					3	XW2Z-300H-3		
			5	XW2Z-500H-3				
			10	XW2Z-010H-3				
G7TC-IA16/ID16 G7TC-OC16/08 G70D-SOC16/ VSOC16 G70A-ZOC16-3	1:3	1.5	G79-150C-125-100	402				
		2	G79-200C-175-150					
		3	G79-300C-275-250					

I/O Unit model	Connector-Terminal Conversion Unit or I/O Block model	Connecting Cable			Page			
		Branching	Length (m)	Model				
CS1W-MD292 (48 inputs) (48 outputs)	XW2B-60G5 XW2B-60G4	1:1	0.5	XW2Z-050H-1	413			
			1	XW2Z-100H-1				
			1.5	XW2Z-150H-1				
			2	XW2Z-200H-1				
			3	XW2Z-300H-1				
			5	XW2Z-500H-1				
			7	XW2Z-700H-1				
		10	XW2Z-010H-1					
		1:2	1	XW2Z-100H-2				
			1.5	XW2Z-150H-2				
	2		XW2Z-200H-2					
	XW2D-20G6 + XW2D-40G6 XW2B-20G5 + XW2B-40G5 XW2B-20G4 + XW2B-40G4	1:3	1	XW2Z-100H-3				
			1.5	XW2Z-150H-3				
			2	XW2Z-200H-3				
			3	XW2Z-300H-3				
	XW2D-20G6 (3 Units) XW2B-20G5 (3 Units) XW2B-20G4 (3 Units)	1:3	5	XW2Z-500H-3				
			10	XW2Z-010H-3				
			G7TC-IA16/ID16 G7TC-OC16-1	1:3		1.5	G79-150C-125-100	402
						2	G79-200C-175-150	
	3	G79-300C-275-250						
CS1W-ID231 (32 points)	XW2D-40G6 XW2B-40G5 XW2B-40G4	1:1	0.5	XW2Z-050B	412			
			1	XW2Z-100B				
			1.5	XW2Z-150B				
			2	XW2Z-200B				
			3	XW2Z-300B				
	XW2D-40C6	1:1	5	XW2Z-500B				
			0.5	XW2Z-050BU				
			1	XW2Z-100BU				
			1.5	XW2Z-150BU				
			2	XW2Z-200BU				
	XW2D-20G6 (2 Units) XW2B-20G5 (2 Units) XW2B-20G4 (2 Units) XW2B-40G5-T XW2C-20G6-IO16 (2 Units) XW2C-20G5-IN16 (2 Units) XW2E-20G5-IN16 (2 Units)	1:2	3	XW2Z-300BU				
			5	XW2Z-500BU				
			1	XW2Z-100D				
			1.5	XW2Z-150D				
			2	XW2Z-200D				
CS1W-ID231 (32 points)	XW2D-40G6 XW2B-40G5 XW2B-40G4	1:1	3	XW2Z-300D	412			
			5	XW2Z-500D				
			1	XW2Z-100L				
			1.5	XW2Z-150L				
			2	XW2Z-200L				
XW2D-40C6	1:1	3	XW2Z-300L					
		5	XW2Z-500L					
		1	XW2Z-100L					
		1.5	XW2Z-150L					
		2	XW2Z-200L					
XW2D-20G6 (2 Units) XW2B-20G5 (2 Units) XW2B-20G4 (2 Units) XW2B-40G5-T XW2C-20G6-IO16 (2 Units)	1:2	3	XW2Z-300L					
		5	XW2Z-500L					

I/O Unit model	Connector-Terminal Conversion Unit or I/O Block model	Connecting Cable			Page		
		Branching	Length (m)	Model			
CS1W-OD232 (32 points)	XW2D-40G6 XW2B-40G5 XW2B-40G4	1:1	0.5	XW2Z-050B	412		
			1	XW2Z-100B			
			1.5	XW2Z-150B			
			2	XW2Z-200B			
			3	XW2Z-300B			
			5	XW2Z-500B			
			10	XW2Z-010B			
		1:1	1	XW2Z-100BU			
			1.5	XW2Z-150BU			
			2	XW2Z-200BU			
	XW2D-40C6	1:1	3	XW2Z-300BU			
			5	XW2Z-500BU			
			0.5	XW2Z-050BU			
			1	XW2Z-100BU			
	XW2D-20G6 (2 Units) XW2B-20G5 (2 Units) XW2B-20G4 (2 Units) XW2B-40G5-T XW2C-20G6-IO16 (2 Units)	1:2	1.5	XW2Z-150BU			
			2	XW2Z-200BU			
			3	XW2Z-300BU			
			5	XW2Z-500BU			
	CS1W-ID261 (32 points 2)	XW2D-40G6 XW2B-40G5 XW2B-40G4	1:1	1		XW2Z-100L	412
				1.5		XW2Z-150L	
2				XW2Z-200L			
3				XW2Z-300L			
XW2D-40C6	1:1	5	XW2Z-500L				
		0.5	XW2Z-050BU				
		1	XW2Z-100BU				
		1.5	XW2Z-150BU				
XW2D-20G6 (2 Units) XW2B-20G5 (2 Units) XW2B-20G4 (2 Units) XW2B-40G5-T XW2C-20G6-IO16 (2 Units) XW2C-20G5-IN16 (2 Units) XW2E-20G5-IN16 (2 Units)	1:2	2	XW2Z-200BU				
		3	XW2Z-300BU				
		5	XW2Z-500BU				
		1	XW2Z-100D				
CS1W-OD261 (32 points 2)	XW2D-40G6 XW2B-40G5 XW2B-40G4	1:1	1.5	XW2Z-150D	412		
			2	XW2Z-200D			
			3	XW2Z-300D			
			5	XW2Z-500D			
XW2D-40C6	1:1	1	XW2Z-100D				
		1.5	XW2Z-150D				
		2	XW2Z-200D				
		3	XW2Z-300D				
XW2D-20G6 (2 Units) XW2B-20G5 (2 Units) XW2B-20G4 (2 Units) XW2B-40G5-T XW2C-20G6-IO16 (2 Units)	1:2	5	XW2Z-500D				
		1	XW2Z-100L				
		1.5	XW2Z-150L				
		2	XW2Z-200L				
CS1W-OD261 (32 points 2)	XW2D-40G6 XW2B-40G5 XW2B-40G4	1:1	3	XW2Z-300L	412		
			5	XW2Z-500L			
			1	XW2Z-100L			
			1.5	XW2Z-150L			
XW2D-40C6	1:1	2	XW2Z-200L				
		3	XW2Z-300L				
		5	XW2Z-500L				
		0.5	XW2Z-050BU				
XW2D-20G6 (2 Units) XW2B-20G5 (2 Units) XW2B-20G4 (2 Units) XW2B-40G5-T XW2C-20G6-IO16 (2 Units)	1:2	1	XW2Z-100L				
		1.5	XW2Z-150L				
		2	XW2Z-200L				
		3	XW2Z-300L				
CS1W-OD262 (32 points 2)	XW2D-40G6 XW2B-40G5 XW2B-40G4	1:1	5	XW2Z-500L	413		
			0.5	XW2Z-050BU			
			1	XW2Z-100BU			
			1.5	XW2Z-150BU			
XW2D-40C6	1:1	2	XW2Z-200BU				
		3	XW2Z-300BU				
		5	XW2Z-500BU				
		0.5	XW2Z-050BU				
XW2D-20G6 (2 Units) XW2B-20G5 (2 Units) XW2B-20G4 (2 Units) XW2B-40G5-T XW2C-20G6-IO16 (2 Units)	1:2	1	XW2Z-100L				
		1.5	XW2Z-150L				
		2	XW2Z-200L				
		3	XW2Z-300L				
CS1W-OD262 (32 points 2)	XW2D-40G6 XW2B-40G5 XW2B-40G4	1:1	5	XW2Z-500L	413		
			0.5	XW2Z-050BU			
			1	XW2Z-100BU			
			1.5	XW2Z-150BU			
XW2D-40C6	1:1	2	XW2Z-200BU				
		3	XW2Z-300BU				
		5	XW2Z-500BU				
		0.5	XW2Z-050BU				
XW2D-20G6 (2 Units) XW2B-20G5 (2 Units) XW2B-20G4 (2 Units) XW2B-40G5-T XW2C-20G6-IO16 (2 Units)	1:2	1	XW2Z-100L				
		1.5	XW2Z-150L				
		2	XW2Z-200L				
		3	XW2Z-300L				

I/O Unit model	Connector-Terminal Conversion Unit or I/O Block model	Connecting Cable				Page
		Branching	Length (m)	Model		
CS1W-MD261 (32 inputs)	XW2D-40G6 XW2B-40G5 XW2B-40G4	1:1	0.5	XW2Z-050B	412	
			1	XW2Z-100B		
			1.5	XW2Z-150B		
			2	XW2Z-200B		
			3	XW2Z-300B		
	5	XW2Z-500B				
	XW2D-40C6	1:1	0.5	XW2Z-050BU		
			1	XW2Z-100BU		
			1.5	XW2Z-150BU		
			2	XW2Z-200BU		
			3	XW2Z-300BU		
	XW2D-20G6 (2 Units) XW2B-20G5 (2 Units) XW2B-20G4 (2 Units) XW2B-40G5-T XW2C-20G6-IO16 (2 Units) XW2C-20G5-IN16 (2 Units) XW2E-20G5-IN16 (2 Units)	1:2	1	XW2Z-100D		
			1.5	XW2Z-150D		
			2	XW2Z-200D		
			3	XW2Z-300D		
5			XW2Z-500D			
CS1W-MD261 (32 outputs)	XW2D-40G6 XW2B-40G5 XW2B-40G4	1:1	0.5	XW2Z-050B	412	
			1	XW2Z-100B		
			1.5	XW2Z-150B		
			2	XW2Z-200B		
			3	XW2Z-300B		
	5	XW2Z-500B				
	XW2D-40C6	1:1	0.5	XW2Z-050BU		
			1	XW2Z-100BU		
			1.5	XW2Z-150BU		
			2	XW2Z-200BU		
			3	XW2Z-300BU		
	XW2D-20G6 (2 Units) XW2B-20G5 (2 Units) XW2B-20G4 (2 Units) XW2B-40G5-T XW2C-20G6-IO16 (2 Units)	1:2	1	XW2Z-100L		413
			1.5	XW2Z-150L		
			2	XW2Z-200L		
			3	XW2Z-300L		
5			XW2Z-500L			
CS1W-MD262 (32 inputs)	XW2D-40G6 XW2B-40G5 XW2B-40G4	1:1	0.5	XW2Z-050B	412	
			1	XW2Z-100B		
			1.5	XW2Z-150B		
			2	XW2Z-200B		
			3	XW2Z-300B		
	5	XW2Z-500B				
	XW2D-40C6	1:1	0.5	XW2Z-050BU		
			1	XW2Z-100BU		
			1.5	XW2Z-150BU		
			2	XW2Z-200BU		
			3	XW2Z-300BU		
	XW2D-20G6 (2 Units) XW2B-20G5 (2 Units) XW2B-20G4 (2 Units) XW2B-40G5-T XW2C-20G6-IO16 (2 Units) XW2C-20G5-IN16 (2 Units) XW2E-20G5-IN16 (2 Units)	1:2	1	XW2Z-100D		
			1.5	XW2Z-150D		
			2	XW2Z-200D		
			3	XW2Z-300D		
5			XW2Z-500D			

I/O Unit model	Connector-Terminal Conversion Unit or I/O Block model	Connecting Cable				Page
		Branching	Length (m)	Model		
CS1W-MD262 (32 outputs)	XW2D-40G6 XW2B-40G5 XW2B-40G4	1:1	0.5	XW2Z-050B	412	
			1	XW2Z-100B		
			1.5	XW2Z-150B		
			2	XW2Z-200B		
			3	XW2Z-300B		
	5	XW2Z-500B				
	XW2D-40C6	1:1	0.5	XW2Z-050BU		
			1	XW2Z-100BU		
			1.5	XW2Z-150BU		
			2	XW2Z-200BU		
			3	XW2Z-300BU		
	XW2D-20G6 (2 Units) XW2B-20G5 (2 Units) XW2B-20G4 (2 Units) XW2B-40G5-T XW2C-20G6-IO16 (2 Units)	1:2	1	XW2Z-100L		413
			1.5	XW2Z-150L		
			2	XW2Z-200L		
			3	XW2Z-300L		
5			XW2Z-500L			

Connecting to CJ1 I/O Units

I/O Unit model	Connector-Terminal Conversion Unit or I/O Block model	Connecting Cable				
		Branching	Length (m)	Model	Page	
CJ1W-ID231 (32 points)	XW2D-40G6 XW2D-40G6-RF XW2B-40G5 XW2B-40G4	1:1	0.5	XW2Z-050B	412	
			1	XW2Z-100B		
			1.5	XW2Z-150B		
			2	XW2Z-200B		
			3	XW2Z-300B		
		5	XW2Z-500B			
		XW2D-40C6	1:1	0.5		XW2Z-050BU
				1		XW2Z-100BU
				1.5		XW2Z-150BU
				2		XW2Z-200BU
	3			XW2Z-300BU		
	XW2D-20G6 (2 Units) XW2B-20G5 (2 Units) XW2B-20G4 (2 Units) XW2B-40G5-T XW2C-20G6-IO16 (2 Units) XW2C-20G5-IN16 (2 Units) XW2E-20G5-IN16 (2 Units)	1:2	1	XW2Z-100D		
			1.5	XW2Z-150D		
			2	XW2Z-200D		
			3	XW2Z-300D		
			5	XW2Z-500D		
	G7TC-IA16/ID16	1:2	1	G79-I100C-75	401	
			1.5	G79-I150C-125		
			2	G79-I200C-175		
			3	G79-I300C-275		
5			G79-I500C-475			
CJ1W-OD231 (32 points)	XW2D-40G6 XW2B-40G5 XW2B-40G4	1:1	0.5	XW2Z-050B	412	
			1	XW2Z-100B		
			1.5	XW2Z-150B		
			2	XW2Z-200B		
			3	XW2Z-300B		
		5	XW2Z-500B			
		XW2D-40C6	1:1	0.5		XW2Z-050BU
				1		XW2Z-100BU
				1.5		XW2Z-150BU
				2		XW2Z-200BU
	3			XW2Z-300BU		
	XW2D-20G6 (2 Units) XW2B-20G5 (2 Units) XW2B-20G4 (2 Units) XW2B-40G5-T XW2C-20G6-IO16 (2 Units)	1:2	1	XW2Z-100L	413	
			1.5	XW2Z-150L		
			2	XW2Z-200L		
			3	XW2Z-300L		
			5	XW2Z-500L		
	G7TC-OC16/08 G70D-SOC16/ VSOC16 G70A-ZOC16-3	1:2	1	G79-O100C-75	401	
			1.5	G79-O150C-125		
			2	G79-O200C-175		
			3	G79-O300C-275		
5			G79-O500C-475			
CJ1W-ID232 (32 points)	XW2D-40G6 XW2D-40G6-RM XW2B-40G5 XW2B-40G4	1:1	1	XW2Z-100K	414	
			1.5	XW2Z-150K		
			2	XW2Z-200K		
			3	XW2Z-300K		
			5	XW2Z-500K		
	XW2D-20G6 (2 Units) XW2B-20G5 (2 Units) XW2B-20G4 (2 Units) XW2B-40G5-T XW2C-20G6-IO16 (2 Units) XW2C-20G5-IN16 (2 Units) XW2E-20G5-IN16 (2 Units)	1:2	1	XW2Z-100N		
			1.5	XW2Z-150N		
			2	XW2Z-200N		
			3	XW2Z-300N		
			5	XW2Z-500N		

I/O Unit model	Connector-Terminal Conversion Unit or I/O Block model	Connecting Cable				
		Branching	Length (m)	Model	Page	
CJ1W-OD232 (32 points)	XW2D-40G6 XW2B-40G5 XW2B-40G4	1:1	1	XW2Z-100K	414	
			1.5	XW2Z-150K		
			2	XW2Z-200K		
			3	XW2Z-300K		
			5	XW2Z-500K		
	XW2D-20G6 (2 Units) XW2B-20G5 (2 Units) XW2B-20G4 (2 Units) XW2B-40G5-T XW2C-20G6-IO16 (2 Units)	1:2	1	XW2Z-100N		
			1.5	XW2Z-150N		
			2	XW2Z-200N		
			3	XW2Z-300N		
			5	XW2Z-500N		
CJ1W-OD233 (32 points)	XW2D-40G6 XW2B-40G5 XW2B-40G4	1:1	1	XW2Z-100K	414	
			1.5	XW2Z-150K		
			2	XW2Z-200K		
			3	XW2Z-300K		
			5	XW2Z-500K		
	XW2D-20G6 (2 units) XW2B-20G5 (2 units) XW2B-20G4 (2units) XW2B-40G5-T XW2C-20G6-IO16 (2 units)	1:2	1	XW2Z-100N		
			1.5	XW2Z-150N		
			2	XW2Z-200N		
			3	XW2Z-300N		
			5	XW2Z-500N		
CJ1W-MD231 (16 inputs)	XW2D-20G6 XW2B-20G5 XW2B-20G4 XW2C-20G6-IO16 XW2C-20G5-IN16 XW2E-20G5-IN16	1:1	0.5	XW2Z-050A	412	
			1	XW2Z-100A		
			1.5	XW2Z-150A		
			2	XW2Z-200A		
			3	XW2Z-300A		
	5	XW2Z-500A				
	XW2D-20C6	1:1	0.5	XW2Z-050AU		412
			1	XW2Z-100AU		
			1.5	XW2Z-150AU		
			2	XW2Z-200AU		
3			XW2Z-300AU			
5	XW2Z-500AU					
CJ1W-MD231 (16 outputs)	XW2D-20G6 XW2B-20G5 XW2B-20G4 XW2C-20G6-IO16	1:1	0.5	XW2Z-050A	412	
			1	XW2Z-100A		
			1.5	XW2Z-150A		
			2	XW2Z-200A		
			3	XW2Z-300A		
	5	XW2Z-500A				
	XW2D-20C6	1:1	0.5	XW2Z-050AU		412
			1	XW2Z-100AU		
			1.5	XW2Z-150AU		
			2	XW2Z-200AU		
3			XW2Z-300AU			
5	XW2Z-500AU					
CJ1W-MD233 (16 inputs)	XW2D-20G6 XW2B-20G5 XW2B-20G4 XW2C-20G6-IO16 XW2C-20G5-IN16 XW2E-20G5-IN16	1:1	0,25	G79-O25C	401	
			0,5	G79-O50C		

I/O Unit model	Connector-Terminal Conversion Unit or I/O Block model	Connecting Cable				Page
		Branching	Length (m)	Model		
CJ1W-ID261 (32 points x 2)	XW2D-40G6 XW2D-40G6-RF XW2B-40G5 XW2B-40G4	1:1	0.5	XW2Z-050B	412	
			1	XW2Z-100B		
			1.5	XW2Z-150B		
			2	XW2Z-200B		
			3	XW2Z-300B		
	XW2D-40C6	1:1	0.5	XW2Z-050BU		
			1	XW2Z-100BU		
			1.5	XW2Z-150BU		
			2	XW2Z-200BU		
			3	XW2Z-300BU		
	XW2D-20G6 (2 Units) XW2B-20G5 (2 Units) XW2B-20G4 (2 Units) XW2B-40G5-T XW2C-20G6-IO16 (2 Units) XW2C-20G5-IN16 (2 Units) XW2E-20G5-IN16 (2 Units)	1:2	1	XW2Z-100D		
			1.5	XW2Z-150D		
			2	XW2Z-200D		
			3	XW2Z-300D		
			5	XW2Z-500D		
	G7TC-IA16/ID16	1:2	1	G79-I100C-75	401	
			1.5	G79-I150C-125		
			2	G79-I200C-175		
			3	G79-I300C-275		
			5	G79-I500C-475		
CJ1W-OD261 (32 points x 2)	XW2D-40G6 XW2B-40G5 XW2B-40G4	1:1	0.5	XW2Z-050B	412	
			1	XW2Z-100B		
			1.5	XW2Z-150B		
			2	XW2Z-200B		
			3	XW2Z-300B		
	XW2D-40C6	1:1	0.5	XW2Z-050BU		
			1	XW2Z-100BU		
			1.5	XW2Z-150BU		
			2	XW2Z-200BU		
			3	XW2Z-300BU		
	XW2D-20G6 (2 Units) XW2B-20G5 (2 Units) XW2B-20G4 (2 Units) XW2B-40G5-T XW2C-20G6-IO16 (2 Units)	1:2	1	XW2Z-100L	413	
			1.5	XW2Z-150L		
			2	XW2Z-200L		
			3	XW2Z-300L		
			5	XW2Z-500L		
	G7TC-OC16/08 G70D-SOC16/ VSOC16 G70A-ZOC16-3	1:2	1	G79-O100C-75	401	
			1.5	G79-O150C-125		
			2	G79-O200C-175		
			3	G79-O300C-275		
			5	G79-O500C-475		
CJ1W-OD263 (32 points x 2)	XW2D-40G6 XW2B-40G5 XW2B-40G4	1:1	1	XW2Z-100K	414	
			1.5	XW2Z-150K		
			2	XW2Z-200K		
			3	XW2Z-300K		
			5	XW2Z-500K		
	XW2D-20G6 (2 units) XW2B-20G5 (2 units) XW2B-20G4 (2units) XW2B-40G5-T XW2C-20G6-IO16 (2 units)	1:2	1	XW2Z-100N	414	
			1.5	XW2Z-150N		
			2	XW2Z-200N		
			3	XW2Z-300N		
			5	XW2Z-500N		

I/O Unit model	Connector-Terminal Conversion Unit or I/O Block model	Connecting Cable				Page
		Branching	Length (m)	Model		
CJ1W-ID262 (32 points x 2)	XW2D-40G6 XW2D-40G6-RM XW2B-40G5 XW2B-40G4	1:1	1	XW2Z-100K	414	
			1.5	XW2Z-150K		
			2	XW2Z-200K		
			3	XW2Z-300K		
			5	XW2Z-500K		
	XW2D-20G6 (2 units) XW2B-20G5 (2 units) XW2B-20G4 (2units) XW2B-40G5-T XW2C-20G6-IO16 (2 units) XW2C-20G5-IN16 (2 units) XW2E-20G5-IN16 (2 units)	1:2	1	XW2Z-100N	414	
			1.5	XW2Z-150N		
			2	XW2Z-200N		
			3	XW2Z-300N		
			5	XW2Z-500N		
	CJ1W-MD261 (32 Inputs)	XW2D-40G6 XW2D-40G6-RF XW2B-40G5 XW2B-40G4	1:1	0.5	XW2Z-050B	412
				1	XW2Z-100B	
				1.5	XW2Z-150B	
				2	XW2Z-200B	
				3	XW2Z-300B	
XW2D-40C6		1:1	0.5	XW2Z-050BU	412	
			1	XW2Z-100BU		
			1.5	XW2Z-150BU		
			2	XW2Z-200BU		
			3	XW2Z-300BU		
CJ1W-MD261 (32 Outputs)	XW2D-40G6 XW2B-40G5 XW2B-40G4	1:1	0.5	XW2Z-050B	412	
			1	XW2Z-100B		
			1.5	XW2Z-150B		
			2	XW2Z-200B		
			3	XW2Z-300B		
	XW2D-40C6	1:1	0.5	XW2Z-050BU	412	
			1	XW2Z-100BU		
			1.5	XW2Z-150BU		
			2	XW2Z-200BU		
			3	XW2Z-300BU		
CJ1W-MD263 (32 Inputs)	XW2D-40G6 XW2D-40G6-RM XW2B-40G5 XW2B-40G4	1:1	1	XW2Z-100K	414	
			1.5	XW2Z-150K		
			2	XW2Z-200K		
			3	XW2Z-300K		
			5	XW2Z-500K		
	XW2D-20G6 (2 units) XW2B-20G5 (2 units) XW2B-20G4 (2units) XW2B-40G5-T XW2C-20G6-IO16 (2 units) XW2C-20G5-IN16 (2 units) XW2E-20G5-IN16 (2 units)	1:2	1	XW2Z-100N	414	
			1.5	XW2Z-150N		
			2	XW2Z-200N		
			3	XW2Z-300N		
			5	XW2Z-500N		

I/O Unit model	Connector-Terminal Conversion Unit or I/O Block model	Connecting Cable			Page
		Branching	Length (m)	Model	
CJ1W-MD263 (32 Outputs)	XW2D-40G6	1:1	1	XW2Z-100K	414
	XW2B-40G5		1,5	XW2Z-150K	
	XW2B-40G4		2	XW2Z-200K	
			3	XW2Z-300K	
			5	XW2Z-500K	
	XW2D-20G6 (2 units)	1:2	1	XW2Z-100N	414
	XW2B-20G5 (2 units)		1,5	XW2Z-150N	
	XW2B-20G4 (2units)		2	XW2Z-200N	
	XW2B-40G5-T		3	XW2Z-300N	
	XW2C-20G6-IO16 (2 units)		5	XW2Z-500N	
CJ1W-MD563 (32 Inputs)	XW2D-40G6	1:1	1	XW2Z-100K	414
	XW2D-40G6-RM		1,5	XW2Z-150K	
	XW2B-40G5		2	XW2Z-200K	
	XW2B-40G4		3	XW2Z-300K	
			5	XW2Z-500K	
	XW2D-20G6 (2 units)	1:2	1	XW2Z-100N	414
	XW2B-20G5 (2 units)		1,5	XW2Z-150N	
	XW2B-20G4 (2units)		2	XW2Z-200N	
	XW2B-40G5-T		3	XW2Z-300N	
	XW2C-20G6-IO16 (2 units)		5	XW2Z-500N	
CJ1W-MD563 (32 Outputs)	XW2D-40G6	1:1	1	XW2Z-100K	414
	XW2B-40G5		1,5	XW2Z-150K	
	XW2B-40G4		2	XW2Z-200K	
			3	XW2Z-300K	
			5	XW2Z-500K	
	XW2D-20G6 (2 units)	1:2	1	XW2Z-100N	414
	XW2B-20G5 (2 units)		1,5	XW2Z-150N	
	XW2B-20G4 (2units)		2	XW2Z-200N	
	XW2B-40G5-T		3	XW2Z-300N	
	XW2C-20G6-IO16 (2 units)		5	XW2Z-500N	

Connecting to CPM2C I/O Units

I/O Unit model	Connector-Terminal Conversion Unit or I/O Block model	Connecting Cable			Page
		Branching	Length (m)	Model	
CPM2C-10CDTC-D (6 inputs) (4 outputs)	XW2D-20G6 XW2B-20G5 XW2B-20G4	1:1	0.5	XW2Z-050A	412
			1	XW2Z-100A	
			1.5	XW2Z-150A	
			2	XW2Z-200A	
			3	XW2Z-300A	
	XW2D-20C6	1:1	0.5	XW2Z-050AU	
			1	XW2Z-100AU	
			1.5	XW2Z-150AU	
			2	XW2Z-200AU	
			3	XW2Z-300AU	
	G7TC-IA16/ID16 G7TC-OC16/08 G70D-SOC16/VSOC16 G70A-ZOC16-3	1:1	1	G79-100C	401
			1.5	G79-150C	
			2	G79-200C	
			3	G79-300C	
			5	G79-500C	

I/O Unit model	Connector-Terminal Conversion Unit or I/O Block model	Connecting Cable			Page
		Branching	Length (m)	Model	
CPM2C-10C1DTC-D (6 inputs) (4 outputs)	XW2D-20G6 XW2B-20G5 XW2B-20G4	1:1	0.5	XW2Z-050A	412
			1	XW2Z-100A	
			1.5	XW2Z-150A	
			2	XW2Z-200A	
			3	XW2Z-300A	
	XW2D-20C6	1:1	0.5	XW2Z-050AU	
			1	XW2Z-100AU	
			1.5	XW2Z-150AU	
			2	XW2Z-200AU	
			3	XW2Z-300AU	
	G7TC-IA16/ID16 G7TC-OC16/08 G70D-SOC16/VSOC16 G70A-ZOC16-3	1:1	1	G79-100C	401
			1.5	G79-150C	
			2	G79-200C	
			3	G79-300C	
			5	G79-500C	

I/O Unit model	Connector-Terminal Conversion Unit or I/O Block model	Connecting Cable			Page
		Branching	Length (m)	Model	
CPM2C-10CDT1C-D (6 inputs) (4 outputs)	XW2D-20G6 XW2B-20G5 XW2B-20G4	1:1	0.5	XW2Z-050A	412
			1	XW2Z-100A	
			1.5	XW2Z-150A	
			2	XW2Z-200A	
			3	XW2Z-300A	
	XW2D-20C6	1:1	0.5	XW2Z-050AU	412
			1	XW2Z-100AU	
			1.5	XW2Z-150AU	
			2	XW2Z-200AU	
			3	XW2Z-300AU	
	G7TC-OC16-1	1:1	1	G79-100C	401
			1.5	G79-150C	
			2	G79-200C	
			3	G79-300C	
			5	G79-500C	
CPM2C-10C1DT1C-D (6 inputs) (4 outputs)	XW2D-20G6 XW2B-20G5 XW2B-20G4	1:1	0.5	XW2Z-050A	412
			1	XW2Z-100A	
			1.5	XW2Z-150A	
			2	XW2Z-200A	
			3	XW2Z-300A	
	XW2D-20C6	1:1	0.5	XW2Z-050AU	412
			1	XW2Z-100AU	
			1.5	XW2Z-150AU	
			2	XW2Z-200AU	
			3	XW2Z-300AU	
	G7TC-OC16-1	1:1	1	G79-100C	401
			1.5	G79-150C	
			2	G79-200C	
			3	G79-300C	
			5	G79-500C	
CPM2C-20CDTC-D (12 inputs) (8 outputs)	XW2D-20G6 XW2B-20G5 XW2B-20G4	1:1	0.5	XW2Z-050A	412
			1	XW2Z-100A	
			1.5	XW2Z-150A	
			2	XW2Z-200A	
			3	XW2Z-300A	
	XW2D-20C6	1:1	0.5	XW2Z-050AU	412
			1	XW2Z-100AU	
			1.5	XW2Z-150AU	
			2	XW2Z-200AU	
			3	XW2Z-300AU	
	G7TC-IA16/ID16 G7TC-OC16/08 G70D-SOC16/VSOC16 G70A-ZOC16-3	1:1	1	G79-100C	401
			1.5	G79-150C	
			2	G79-200C	
			3	G79-300C	
			5	G79-500C	
CPM2C-20C1DTC-D (12 inputs) (8 outputs)	XW2D-20G6 XW2B-20G5 XW2B-20G4	1:1	0.5	XW2Z-050A	412
			1	XW2Z-100A	
			1.5	XW2Z-150A	
			2	XW2Z-200A	
			3	XW2Z-300A	
	XW2D-20C6	1:1	0.5	XW2Z-050AU	412
			1	XW2Z-100AU	
			1.5	XW2Z-150AU	
			2	XW2Z-200AU	
			3	XW2Z-300AU	
	G7TC-IA16/ID16 G7TC-OC16/08 G70D-SOC16/VSOC16 G70A-ZOC16-3	1:1	1	G79-100C	401
			1.5	G79-150C	
			2	G79-200C	
			3	G79-300C	
			5	G79-500C	

I/O Unit model	Connector-Terminal Conversion Unit or I/O Block model	Connecting Cable			Page	
		Branching	Length (m)	Model		
CPM2C-20CDT1C-D (12 inputs) (8 outputs)	XW2D-20G6 XW2B-20G5 XW2B-20G4	1:1	0.5	XW2Z-050A	412	
			1	XW2Z-100A		
			1.5	XW2Z-150A		
			2	XW2Z-200A		
			3	XW2Z-300A		
	XW2D-20C6	1:1	0.5	XW2Z-050AU	412	
			1	XW2Z-100AU		
			1.5	XW2Z-150AU		
			2	XW2Z-200AU		
			3	XW2Z-300AU		
	G7TC-OC16-1	1:1	1	G79-100C	401	
			1.5	G79-150C		
			2	G79-200C		
			3	G79-300C		
			5	G79-500C		
CPM2C-20C1DT1C-D (12 inputs) (8 outputs)	XW2D-20G6 XW2B-20G5 XW2B-20G4	1:1	0.5	XW2Z-050A	412	
			1	XW2Z-100A		
			1.5	XW2Z-150A		
			2	XW2Z-200A		
			3	XW2Z-300A		
	XW2D-20C6	1:1	0.5	XW2Z-050AU	412	
			1	XW2Z-100AU		
			1.5	XW2Z-150AU		
			2	XW2Z-200AU		
			3	XW2Z-300AU		
	G7TC-OC16-1	1:1	1	G79-100C	401	
			1.5	G79-150C		
			2	G79-200C		
			3	G79-300C		
			5	G79-500C		
CPM2C-8EDC (8 inputs)	XW2D-20G6 XW2B-20G5 XW2B-20G4	1:1	0.5	XW2Z-050A	412	
			1	XW2Z-100A		
			1.5	XW2Z-150A		
			2	XW2Z-200A		
			3	XW2Z-300A		
	XW2D-20C6	1:1	0.5	XW2Z-050AU	412	
			1	XW2Z-100AU		
			1.5	XW2Z-150AU		
			2	XW2Z-200AU		
			3	XW2Z-300AU		
	CPM2C-16EDC (16 inputs)	XW2D-20G6 XW2B-20G5 XW2B-20G4	1:1	0.5	XW2Z-050A	412
				1	XW2Z-100A	
				1.5	XW2Z-150A	
				2	XW2Z-200A	
				3	XW2Z-300A	
XW2D-20C6		1:1	0.5	XW2Z-050AU	412	
			1	XW2Z-100AU		
			1.5	XW2Z-150AU		
			2	XW2Z-200AU		
			3	XW2Z-300AU		
CPM2C-8ETC (8 outputs)		XW2D-20G6 XW2B-20G5 XW2B-20G4	1:1	0.5	XW2Z-050A	412
				1	XW2Z-100A	
				1.5	XW2Z-150A	
				2	XW2Z-200A	
				3	XW2Z-300A	
	XW2D-20C6	1:1	0.5	XW2Z-050AU	412	
			1	XW2Z-100AU		
			1.5	XW2Z-150AU		
			2	XW2Z-200AU		
			3	XW2Z-300AU		

I/O Unit model	Connector-Terminal Conversion Unit or I/O Block model	Connecting Cable			Page	
		Branching	Length (m)	Model		
CPM2C-8ET1C (8 outputs)	XW2D-20G6 XW2B-20G5 XW2B-20G4	1:1	0.5	XW2Z-050A	412	
			1	XW2Z-100A		
			1.5	XW2Z-150A		
			2	XW2Z-200A		
			3	XW2Z-300A		
	XW2D-20C6	1:1	0.5	XW2Z-050AU		
			1	XW2Z-100AU		
			1.5	XW2Z-150AU		
			2	XW2Z-200AU		
			3	XW2Z-300AU		
CPM2C-16ETC (16 outputs)	XW2D-20G6 XW2B-20G5 XW2B-20G4	1:1	0.5	XW2Z-050A	412	
			1	XW2Z-100A		
			1.5	XW2Z-150A		
			2	XW2Z-200A		
			3	XW2Z-300A		
	XW2D-20C6	1:1	0.5	XW2Z-050AU		
			1	XW2Z-100AU		
			1.5	XW2Z-150AU		
			2	XW2Z-200AU		
			3	XW2Z-300AU		
CPM2C-16ET1C (16 outputs)	XW2D-20G6 XW2B-20G5 XW2B-20G4	1:1	0.5	XW2Z-050A	412	
			1	XW2Z-100A		
			1.5	XW2Z-150A		
			2	XW2Z-200A		
			3	XW2Z-300A		
	XW2D-20C6	1:1	0.5	XW2Z-050AU		
			1	XW2Z-100AU		
			1.5	XW2Z-150AU		
			2	XW2Z-200AU		
			3	XW2Z-300AU		
CPM2C-24EDTC (16 inputs) (8 outputs)	XW2D-20G6 XW2B-20G5 XW2B-20G4	1:1	0.5	XW2Z-050A	412	
			1	XW2Z-100A		
			1.5	XW2Z-150A		
			2	XW2Z-200A		
			3	XW2Z-300A		
	XW2D-20C6	1:1	0.5	XW2Z-050AU		
			1	XW2Z-100AU		
			1.5	XW2Z-150AU		
			2	XW2Z-200AU		
			3	XW2Z-300AU		
	G7TC-IA16/ID16 G7TC-OC16/08 G70D-SOC16/VSOC16 G70A-ZOC16-3	1:1	1	G79-100C		401
			1.5	G79-150C		
			2	G79-200C		
			3	G79-300C		
			5	G79-500C		
CPM2C-24EDT1C (16 inputs) (8 outputs)	XW2D-20G6 XW2B-20G5 XW2B-20G4	1:1	0.5	XW2Z-050A	412	
			1	XW2Z-100A		
			1.5	XW2Z-150A		
			2	XW2Z-200A		
			3	XW2Z-300A		
	XW2D-20C6	1:1	0.5	XW2Z-050AU		
			1	XW2Z-100AU		
			1.5	XW2Z-150AU		
			2	XW2Z-200AU		
			3	XW2Z-300AU		
	G7TC-OC16-1	1:1	1	G79-100C		401
			1.5	G79-150C		
			2	G79-200C		
			3	G79-300C		
			5	G79-500C		

Connecting to DeviceNet I/O Terminals

I/O Unit model	Connector-Terminal Conversion Unit or I/O Block model	Connecting Cable				
		Branching	Length (m)	Model	Page	
GT1-ID32ML (32 points)	XW2D-40G6 XW2B-40G5 XW2B-40G4	1:1	0.5	XW2Z-050B	412	
			1	XW2Z-100B		
			1.5	XW2Z-150B		
			2	XW2Z-200B		
			3	XW2Z-300B		
			5	XW2Z-500B		
		XW2D-40C6	1:1	0.5	XW2Z-050BU	412
				1	XW2Z-100BU	
				1.5	XW2Z-150BU	
				2	XW2Z-200BU	
	3			XW2Z-300BU		
	G7TC-IA16/ID16	1:1	0.25	G79-I25C	---	
			0.5	G79-I50C		
	GT1-ID32ML-1 (32 points)	XW2D-40G6 XW2B-40G5 XW2B-40G4	1:1	0.5	XW2Z-050B	412
				1	XW2Z-100B	
1.5				XW2Z-150B		
2				XW2Z-200B		
3				XW2Z-300B		
5				XW2Z-500B		
XW2D-40C6			1:1	0.5	XW2Z-050BU	412
				1	XW2Z-100BU	
				1.5	XW2Z-150BU	
				2	XW2Z-200BU	
		3		XW2Z-300BU		
G7TC-OC16/08 G70D-SOC16/VSOC16 G70A-ZOC16-3		1:1	0.25	G79-O25C	---	
			0.5	G79-O50C		
			1	G79-100C		
			2	G79-200C		
	3		G79-300C			
GT1-OD32ML (32 points)	XW2D-40G6 XW2B-40G5 XW2B-40G4	1:1	0.5	XW2Z-050B	412	
			1	XW2Z-100B		
			1.5	XW2Z-150B		
			2	XW2Z-200B		
			3	XW2Z-300B		
			5	XW2Z-500B		
		XW2D-40C6	1:1	0.5	XW2Z-050BU	412
				1	XW2Z-100BU	
				1.5	XW2Z-150BU	
				2	XW2Z-200BU	
	3			XW2Z-300BU		
	G7TC-OC16/08 G70D-SOC16/VSOC16 G70A-ZOC16-3	1:1	0.25	G79-O25C	---	
			0.5	G79-O50C		
			1	G79-100C		
			2	G79-200C		
3			G79-300C			
GT1-OD32ML-1 (32 points)	XW2D-40G6 XW2B-40G5 XW2B-40G4	1:1	0.5	XW2Z-050B	412	
			1	XW2Z-100B		
			1.5	XW2Z-150B		
			2	XW2Z-200B		
			3	XW2Z-300B		
			5	XW2Z-500B		
		XW2D-40C6	1:1	0.5	XW2Z-050BU	412
				1	XW2Z-100BU	
				1.5	XW2Z-150BU	
				2	XW2Z-200BU	
	3			XW2Z-300BU		
	G7TC-OC16/08 G70D-SOC16/VSOC16 G70A-ZOC16-3	1:1	0.25	G79-O25C	---	
			0.5	G79-O50C		
			1	G79-100C		
			2	G79-200C		
3			G79-300C			
GT1-ID16ML (16 points)	XW2D-20G6 XW2B-20G5 XW2B-20G4	1:1	0.5	XW2Z-050A	412	
			1	XW2Z-100A		
			1.5	XW2Z-150A		
			2	XW2Z-200A		
			3	XW2Z-300A		
			5	XW2Z-500A		
		XW2D-20C6	1:1	0.5	XW2Z-050AU	412
				1	XW2Z-100AU	
				1.5	XW2Z-150AU	
				2	XW2Z-200AU	
	3			XW2Z-300AU		
	G7TC-IA16/ID16	1:1	1	G79-100C	401	
			1.5	G79-150C		
			2	G79-200C		
			3	G79-300C		
5			G79-500C			

I/O Unit model	Connector-Terminal Conversion Unit or I/O Block model	Connecting Cable			
		Branching	Length (m)	Model	Page
GT1-ID16ML-1 (16 points)	XW2D-20G6 XW2B-20G5 XW2B-20G4	1:1	0.5	XW2Z-050A	412
			1	XW2Z-100A	
			1.5	XW2Z-150A	
			2	XW2Z-200A	
			3	XW2Z-300A	
	XW2D-20C6	1:1	0.5	XW2Z-050AU	412
			1	XW2Z-100AU	
			1.5	XW2Z-150AU	
			2	XW2Z-200AU	
			3	XW2Z-300AU	
GT1-OD16ML (16 points)	XW2D-20G6 XW2B-20G5 XW2B-20G4	1:1	0.5	XW2Z-050A	412
			1	XW2Z-100A	
			1.5	XW2Z-150A	
			2	XW2Z-200A	
			3	XW2Z-300A	
	XW2D-20C6	1:1	0.5	XW2Z-050AU	412
			1	XW2Z-100AU	
			1.5	XW2Z-150AU	
			2	XW2Z-200AU	
			3	XW2Z-300AU	
G7TC-OC16/08 G70D-SOC16/VSOC16 G70A-ZOC16-3	1:1	1	G79-100C	401	
		1.5	G79-150C		
		2	G79-200C		
		3	G79-300C		
		5	G79-500C		
GT1-OD16ML-1 (16 points)	XW2D-20G6 XW2B-20G5 XW2B-20G4	1:1	0.5	XW2Z-050A	412
			1	XW2Z-100A	
			1.5	XW2Z-150A	
			2	XW2Z-200A	
			3	XW2Z-300A	
	XW2D-20C6	1:1	0.5	XW2Z-050AU	412
			1	XW2Z-100AU	
			1.5	XW2Z-150AU	
			2	XW2Z-200AU	
			3	XW2Z-300AU	
G7TC-OC16/08 G70D-SOC16/VSOC16 G70A-ZOC16-3	1:1	1	G79-100C	401	
		1.5	G79-150C		
		2	G79-200C		
		3	G79-300C		
		5	G79-500C		

Connecting to CompoBus/S I/O Terminals

I/O Unit model	Connector-Terminal Conversion Unit or I/O Block model	Connecting Cable					
		Branching	Length (m)	Model	Page		
SRT2-VID16ML (16 points)	XW2D-20G6 XW2B-20G5 XW2B-20G4 XW2C-20G6-IO16 XW2C-20G5-IN16 XW2E-20G5-IN16 G7TC-IA16/ID16	1:1	0.25	G79-O25C	---		
			0.5	G79-O50C			
		1:1	0.25	G79-I25C	---		
			0.5	G79-I50C			
		SRT2-VID16ML-1 (16 points)	XW2D-20G6 XW2B-20G5 XW2B-20G4 XW2C-20G6-IO16 XW2C-20G5-IN16 XW2E-20G5-IN16	1:1	0.25	G79-O25C	---
					0.5	G79-O50C	
1:1	0.25			G79-O25C	---		
	0.5	G79-O50C					
SRT2-VOD16ML (16 points)	XW2D-20G6 XW2B-20G5 XW2B-20G4 XW2C-20G6-IO16 XW2C-20G5-IN16 XW2E-20G5-IN16 G7TC-OC16/08 G70D-SOC16/ VSOC16 G70A-ZOC16-3	1:1	0.25	G79-O25C	---		
			0.5	G79-O50C			
		1:1	0.25	G79-O25C	---		
			0.5	G79-O50C			
		SRT2-VOD16ML-1 (16 points)	XW2D-20G6 XW2B-20G5 XW2B-20G4 XW2C-20G6-IO16 XW2C-20G5-IN16 XW2E-20G5-IN16 G70A-ZOC16-4	1:1	0.25	G79-O25C	---
					0.5	G79-O50C	
SRT2-ID32ML (32 points)	XW2D-40G6 XW2B-40G5 XW2B-40G4 G7TC-IA16/ID16	1:1	0.25	XW2Z-C25K	414		
			0.5	XW2Z-C50K			
			1	XW2Z-100K			
			1.5	XW2Z-150K			
			2	XW2Z-200K			
		1:2	0.5	G79-I50-25-D1	---		
0.75	G79-I75-50-D1						
SRT2-ID32ML-1 (32 points)	XW2D-40G6 XW2B-40G5 XW2B-40G4	1:1	0.25	XW2Z-C25K	414		
			0.5	XW2Z-C50K			
			1	XW2Z-100K			
			1.5	XW2Z-150K			
			2	XW2Z-200K			
		1:2	0.5	G79-O50-25-D1	---		
0.75	G79-O75-50-D1						
SRT2-OD32ML (32 points)	XW2D-40G6 XW2B-40G5 XW2B-40G4 G7TC-OC16/08 G70D-SOC16/ VSOC16 G70A-ZOC16-3	1:1	0.25	XW2Z-C25K	414		
			0.5	XW2Z-C50K			
			1	XW2Z-100K			
			1.5	XW2Z-150K			
			2	XW2Z-200K			
		1:2	0.5	G79-O50-25-D1	---		
0.75	G79-O75-50-D1						
SRT2-OD32ML-1 (32 points)	XW2D-40G6 XW2B-40G5 XW2B-40G4 G70A-ZOC16-4	1:1	0.25	XW2Z-C25K	414		
			0.5	XW2Z-C50K			
			1	XW2Z-100K			
			1.5	XW2Z-150K			
			2	XW2Z-200K			
		1:2	0.5	G79-M50-25-D1	---		
0.75	G79-M75-50-D1						

I/O Unit model	Connector-Terminal Conversion Unit or I/O Block model	Connecting Cable			Page	
		Branching	Length (m)	Model		
SRT2-MD32ML (32 points)	XW2D-40G6 XW2B-40G5 XW2B-40G4	1:1	0.25	XW2Z-C25K	414	
			0.5	XW2Z-C50K		
			1	XW2Z-100K		
			1.5	XW2Z-150K		
			2	XW2Z-200K		
	1:2	0.5	G79-M50-25-D1	---		
		0.75	G79-M75-50-D1			
	SRT2-MD32ML-1 (32 points)	XW2D-40G6 XW2B-40G5 XW2B-40G4	1:1	0.25	XW2Z-C25K	414
				0.5	XW2Z-C50K	
				1	XW2Z-100K	
1.5				XW2Z-150K		
2				XW2Z-200K		
1:2		0.5	G79-M50-25-D1	---		
		0.75	G79-M75-50-D1			

ALL DIMENSIONS SHOWN ARE IN MILLIMETERS.
To convert millimeters into inches, multiply by 0.03937. To convert grams into ounces, multiply by 0.03527.