

PART
NAME

GRABBER STYLE I

PART
No.

HH-3550

REV.
DATE

6/13/06

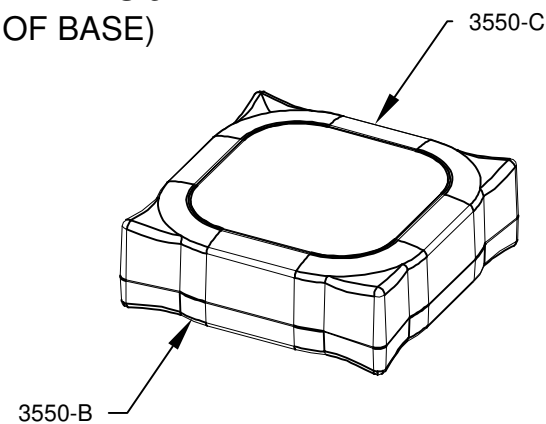
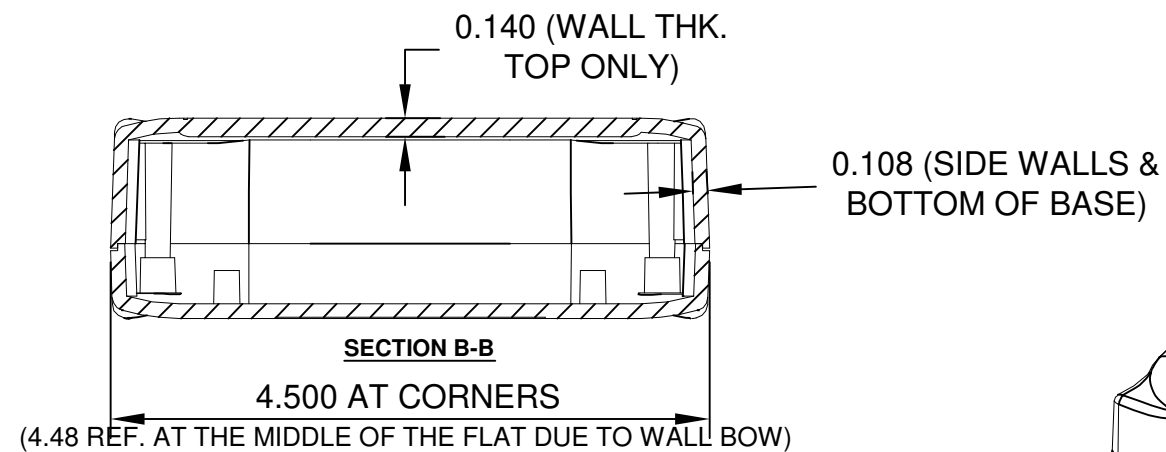
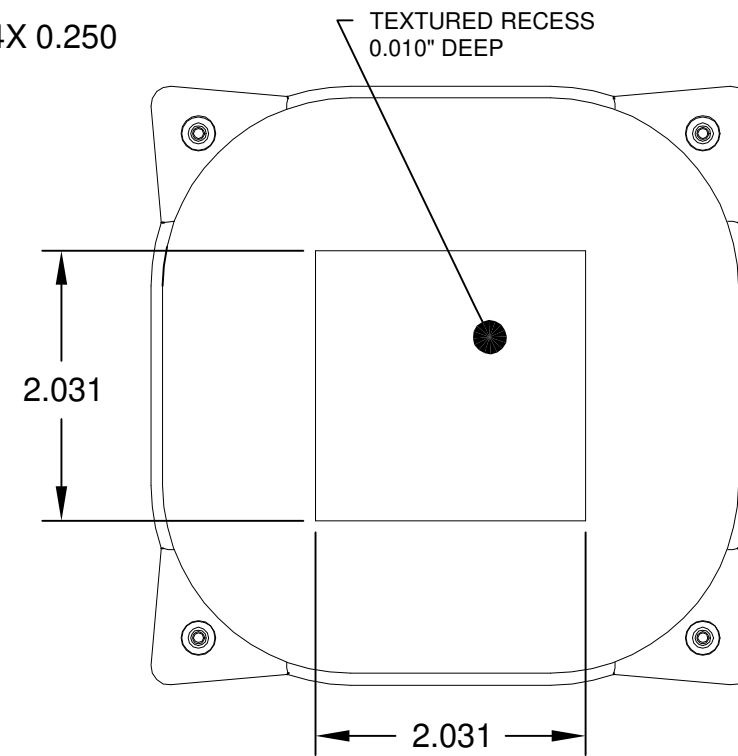
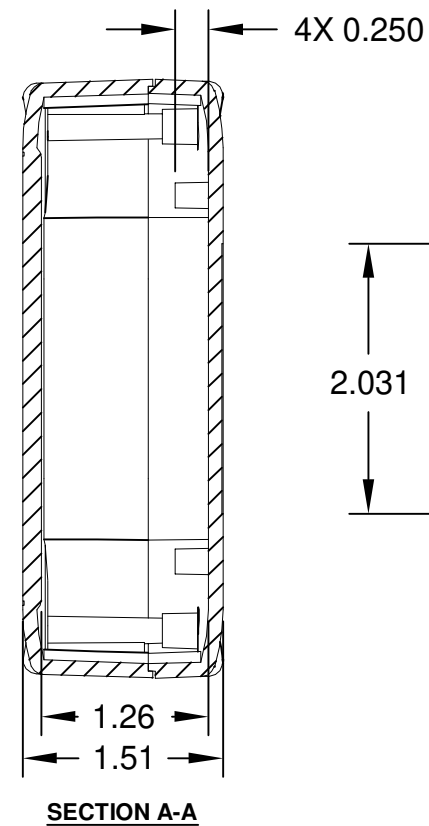
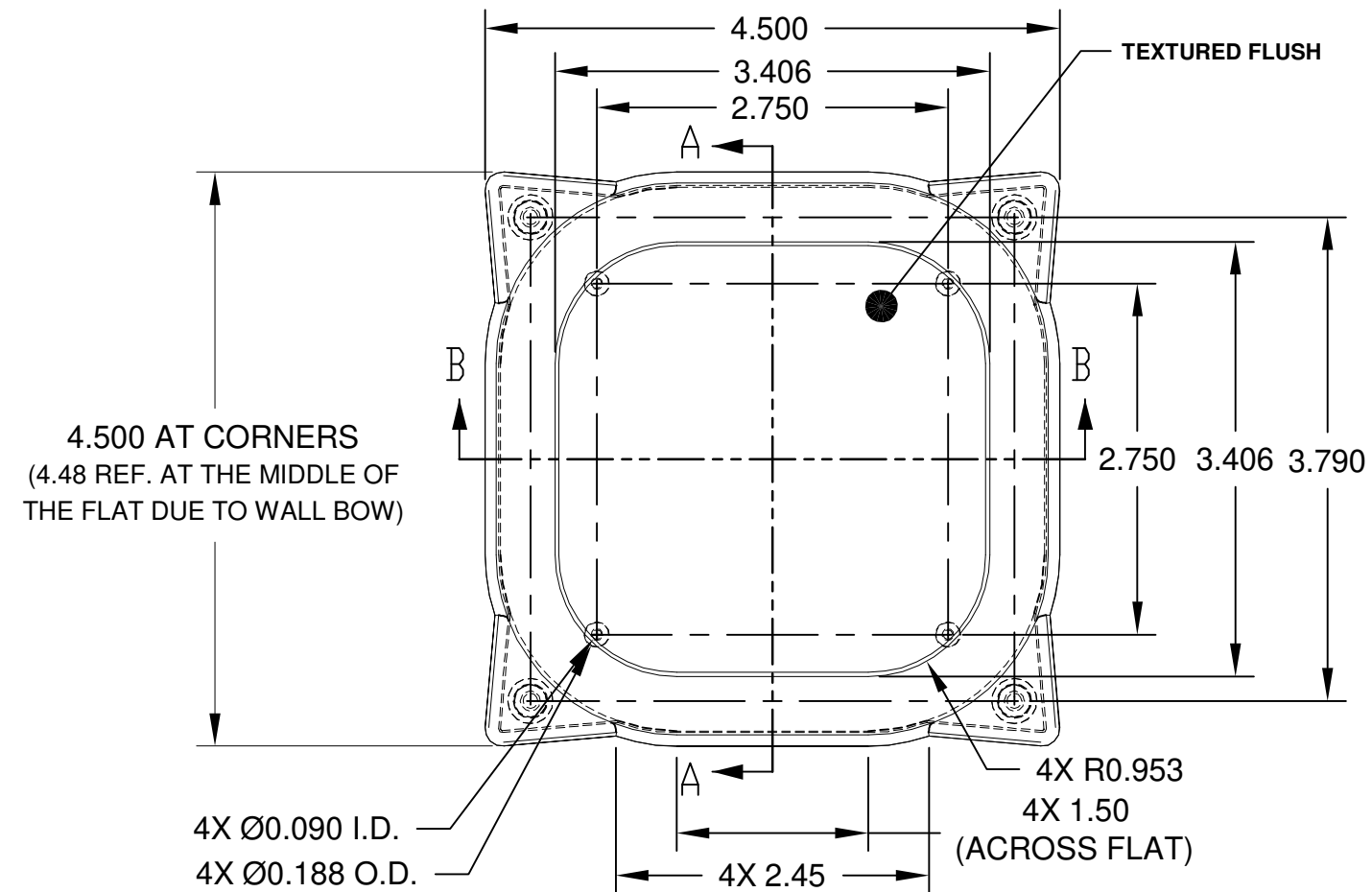

NOTES:

- 1) PC BOARD BOSSES WILL ACCEPT A #4 X 1/4" THREAD FORMING SCREW
- 2) MATERIAL: ABS - UL94-5VA
- 3) FINISH: BLACK TEXTURE
- 4) INCLUDES (4) #4-24 x 5/8 HI-LOW THREAD FORMING, CSK, OVAL HEAD, PHILLIPS DRIVE SCREWS FOR ATTACHING BODY TO COVER