

RI-80 SMD Series Dry Reed Switch

5 mm, 1 Form A, 5 Watt

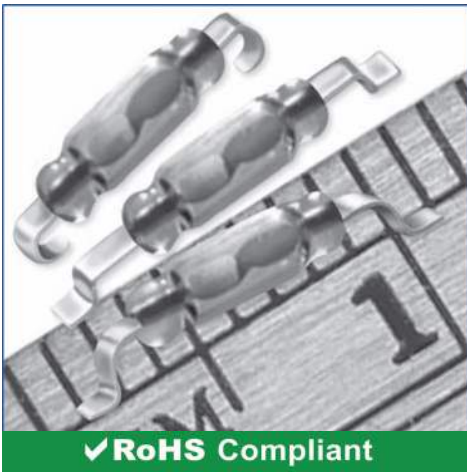

RI-80 SMD Series

Ultra-micro dry-reed switch hermetically sealed in a gas-filled glass envelope. Single-pole, single-throw (SPST) type, having normally open contacts, and containing two magnetically actuated reeds.

The switch is of the double-ended type and may be actuated by an electromagnet, a permanent magnet or a combination of both.

RI-80 SMD Series Features

- Ideal for proximity sensors, telecom & medical applications
- Contact layers: gold, sputtered ruthenium
- Superior glass-to-metal seal and blade alignment
- UL File #E125629

Dimensions for RI-80 SMD Series *All Dimension in inches (mm) nominal*

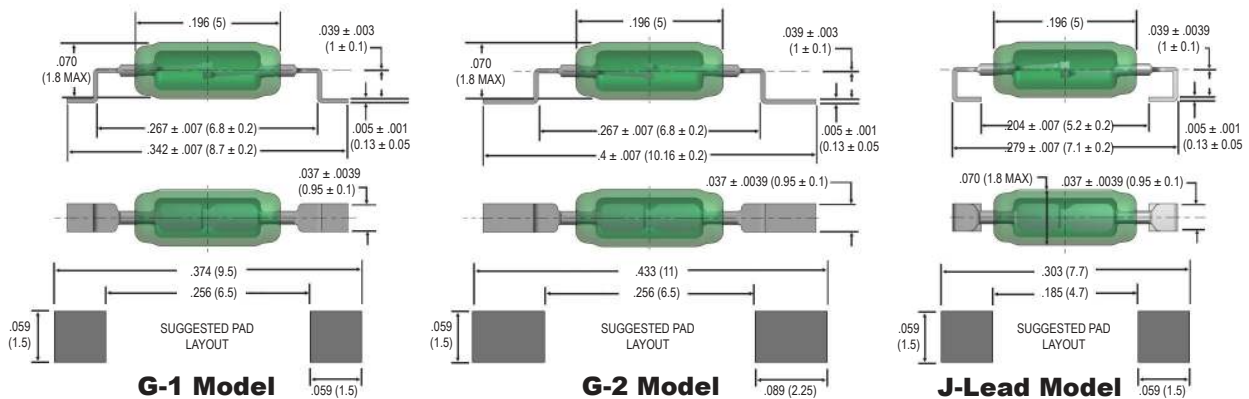

Technical Specifications

Parameters	Test Conditions	Units	RI-80SMD-0510	RI-80SMD-1015
Operating Characteristics				
Operate Range		AT*	5-10	10-15
Release Range		AT*	2-8	4-13
Operate Time - including Bounce (typ.)		ms	0.35	0.35
Bounce Time (typ.)		ms	0.1	0.1
Release Time (max)		µs	20	20
Resonant Frequency (typ.)		Hz	21300	21300
Electrical Characteristics				
Switched Power (max)		W	5	5
Switched Voltage DC (max)		V	175	175
Switched Voltage AC, RMS value (max)		V	140	140
Switched Current DC (max)		mA	350	350
Switched Current AC, RMS value (max)		mA	250	250
Carry Current DC (max)		A	0.5	0.5
Breakdown Voltage (min)		V	175	230
Contact Resistance (initial max.)		mΩ	160	160
Contact Resistance (initial typ.)		mΩ	140	140
Contact Capacitance (max)	without test coil	pF	0.45	0.45
Insulation Resistance (min)	RH ≤ 45%	MΩ	10 ⁶	10 ⁶

*AT values are based on full length, measured using Philips Standard Coil (PSC).

Based on standard RI-80 models

ORDERING INFORMATION

RI-80SMD-XXXX-YY

Series	Lead Configuration Subset:
	G1 for Gull Wing version 1 G2 for Gull Wing version 2 J for J-Lead version
	AT Ranges
	0510 1015

AT-Customization / Performed Leads

Besides the standard models, customized products can also be supplied offering the following options:

- Operate and release ranges to customer specification
- Cropped and/or performed leads

Life expectancy and reliability

The life expectancy data given below are valid for a coil energized at 1.25 times the published maximum operate value for each type in the RI-80 SMD series.

No load conditions (operating frequency: 100Hz)

Life expectancy: min. 10^8 operations with a failure rate of less than 2×10^{-9} with a confidence level of 90%.

End of life criteria:

- Contact resistance > 1Ω after 2 ms
- Release time > 2 ms (latching or contact sticking).

Loaded conditions (resistive load: 5V; 100 mA; operating frequency: 170 Hz)

Life expectancy: min. 10^7 operations with a failure rate of less than 10^{-8} with a confidence level of 90%.

End of life criteria:

- Contact resistance > 1Ω after 4 ms
 - Release time > .7 ms (latching or contact sticking)
- Switching different loads involves different life expectancy and reliability data. Further information available upon request.

Mechanical Data

Contact arrangement is normally open; lead finish is tinned; and can be mounted in any position.

Shock

The switches are tested in accordance with "IEC 68-2-27", test Ea (peak acceleration 150 G, half sinewave; duration 11 ms). Such a shock will not cause an open switch (no

magnetic field present) to close, nor a switch kept closed by an 80 AT coil to open.

Vibration

The switches are tested in accordance with "IEC 68-2-6", test Fc (acceleration 10G; below cross-over-frequency 57 to 62 Hz; amplitude 0.75 mm; frequency range 10 to 2000 Hz; duration 90 minutes.) Such a vibration will not cause an open switch (no magnetic field present) to close, nor a switch kept closed by an 80 AT coil to open.

Mechanical Strength

The robustness of the terminations is tested in accordance with "IEC 68-2-21", test Ua1 (load 10 N).

Operating and Storage Temperature

Operating ambient temperature; min: -55°C ; max: $+125^{\circ}\text{C}$. Storage temperature; min: -55°C ; max: $+125^{\circ}\text{C}$. Note: Temperature excursions up to 150°C may be permissible. For more information contact your nearest Comus Group sales office.

Soldering

The switch can withstand soldering heat in accordance with "IEC 68-2-20", test Tb, method 1B: solder bath at $350 \pm 10^{\circ}\text{C}$ for 3.5 ± 0.5 s. Solderability is tested in accordance with "IEC 68-2-20" test Ta, method 3: solder globule temperature 235°C ; ageing 1b: 4 hours steam.

Surface Mounted Reed Switches

The most common method of attachment is by SMD processing - stencil/screen solder paste, then oven reflow. Due to board thickness, component density, and other circumstances that dictate the required reflow temperature, Comus Technology uses a higher temperature solder for all internal connections. We recommend that the temperature (measured at the reed switch leads) does not exceed 260°C for 1 minute. Temperature and time in excess of the recommended levels may result in damage to the reed switch.

Handling Force

When possible don't add pressure on the glass on placing the reed switch on a pcb or device. However when handling with a Pick and Place machine the acceptable force on the reed switch is 3N with a max of 5N.

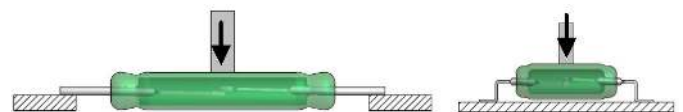

* As part of the company policy of continued product improvement, specifications may change without notice. Our sales office will be pleased to help you with the latest information on this product range and the details of our full design and manufacturing service. All products are supplied to our standard conditions of sale unless otherwise agreed in writing.

Recommended Soldering Reflow Profile

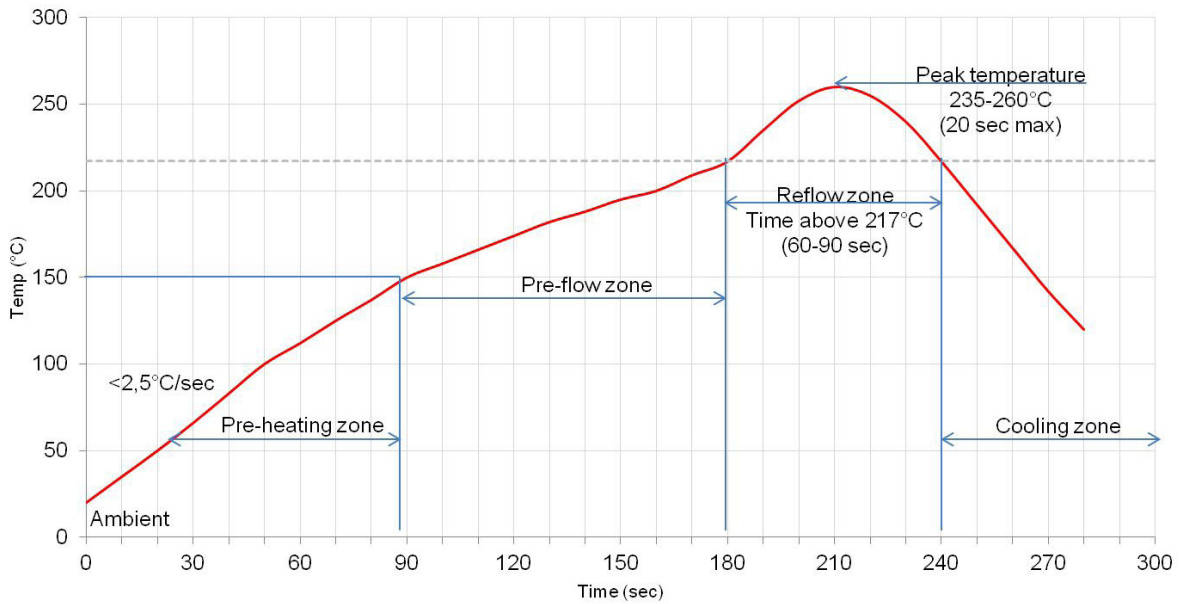

Dimensions for RI-80 SMD Tape and Reel

All Dimension in inches (mm) nominal

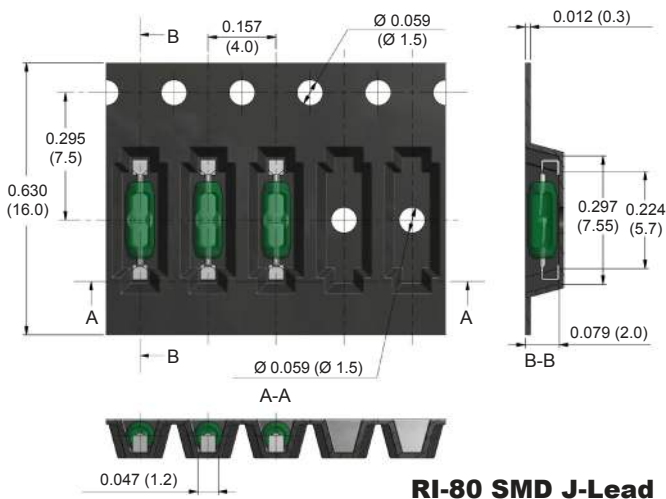
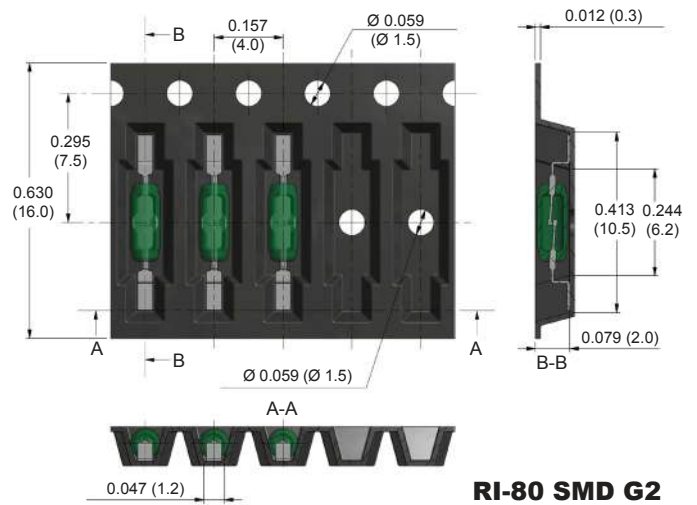
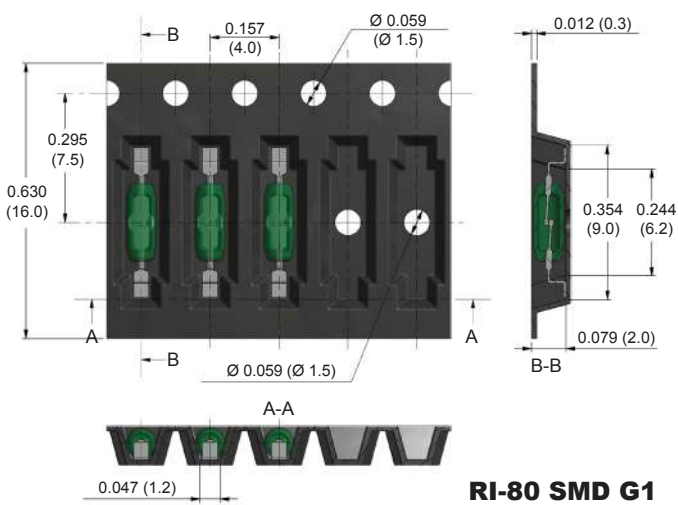

**packing quantity: 2,000 pieces/reel