

REVISIONS				
P	LTR	DESCRIPTION	DATE	BY
-	-	SEE SHEET 1	-	-

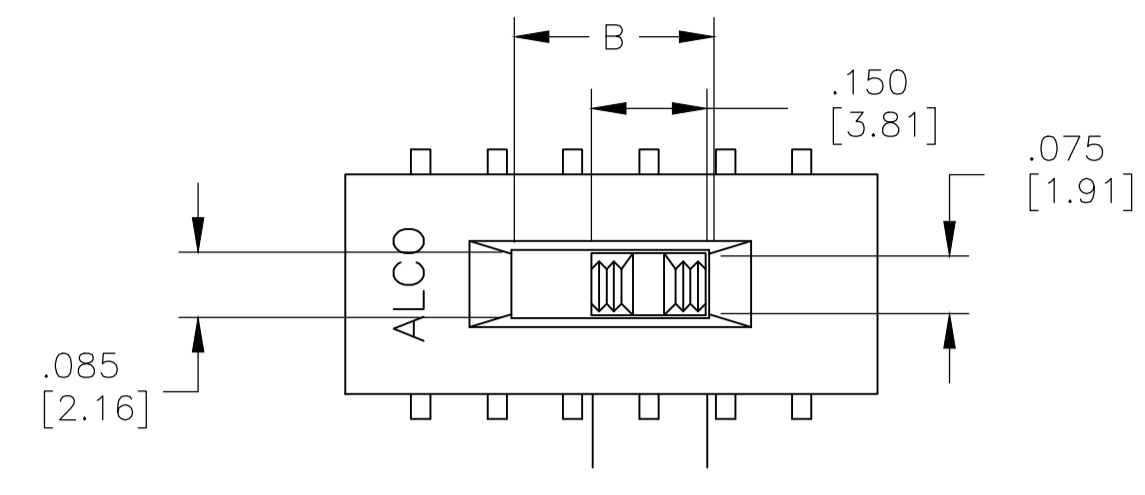

* SIDE ACTUATOR ONLY.

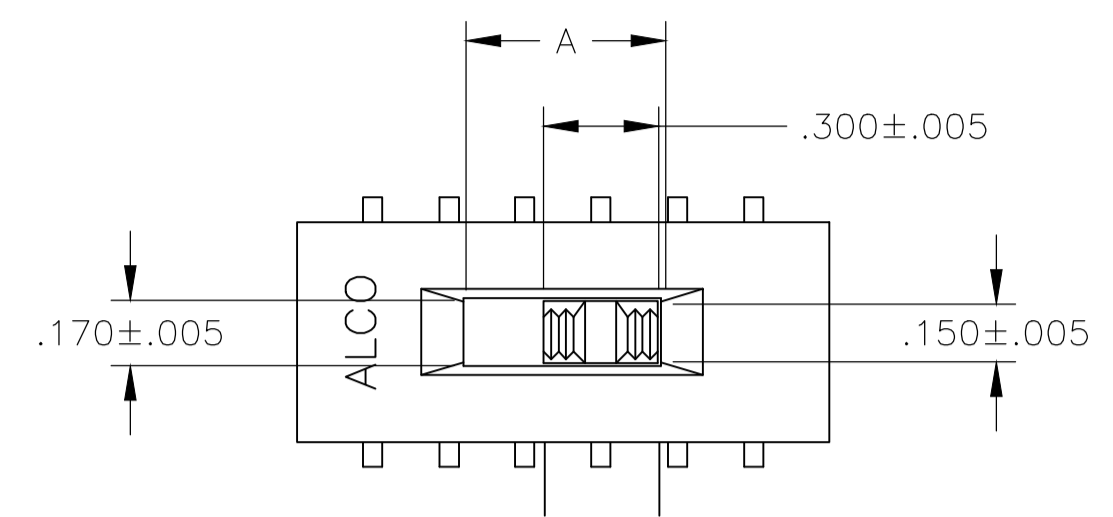

* SIDE ACTUATOR ONLY.

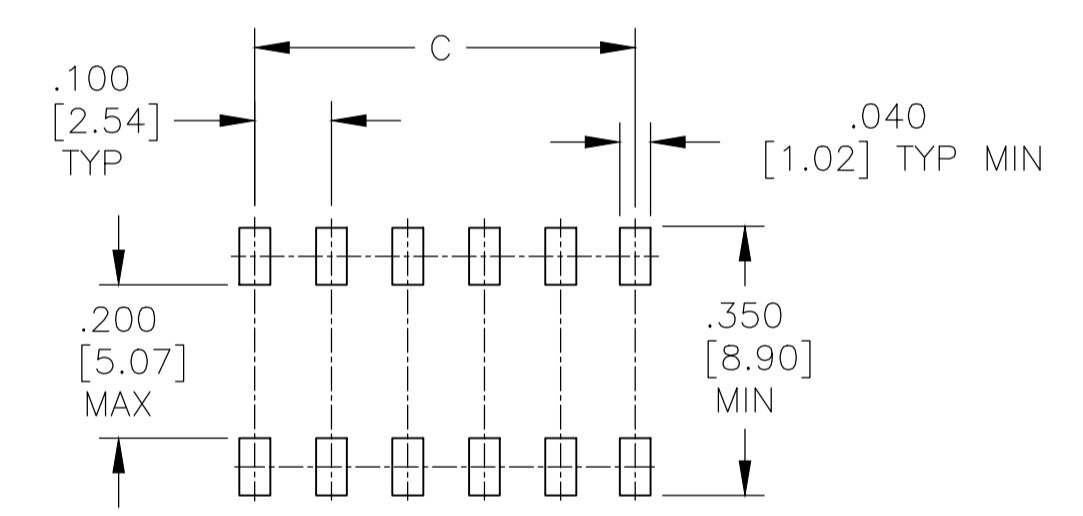
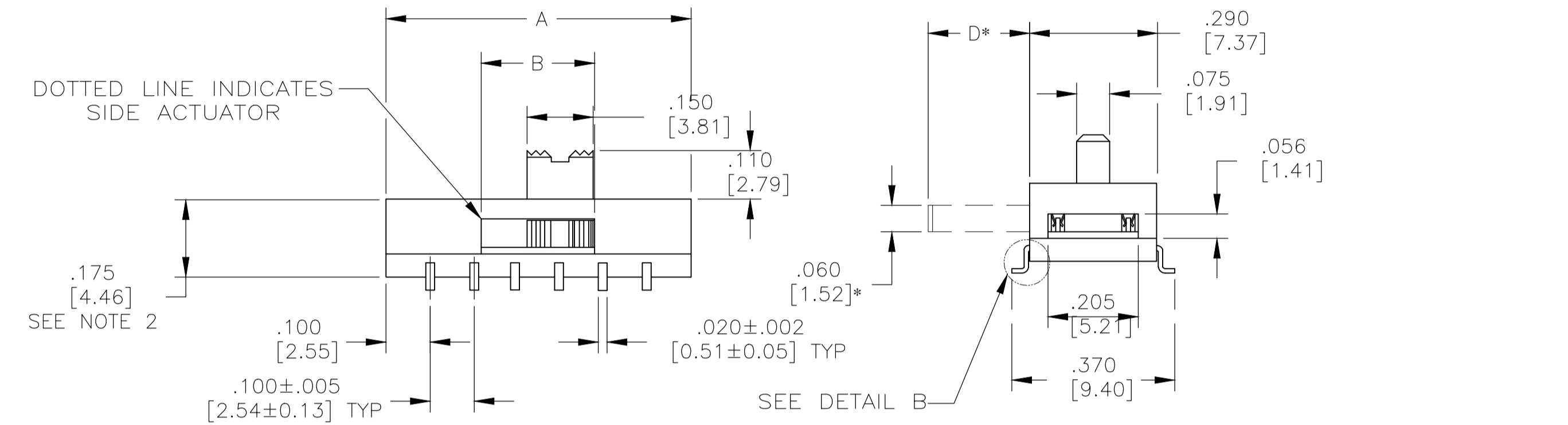
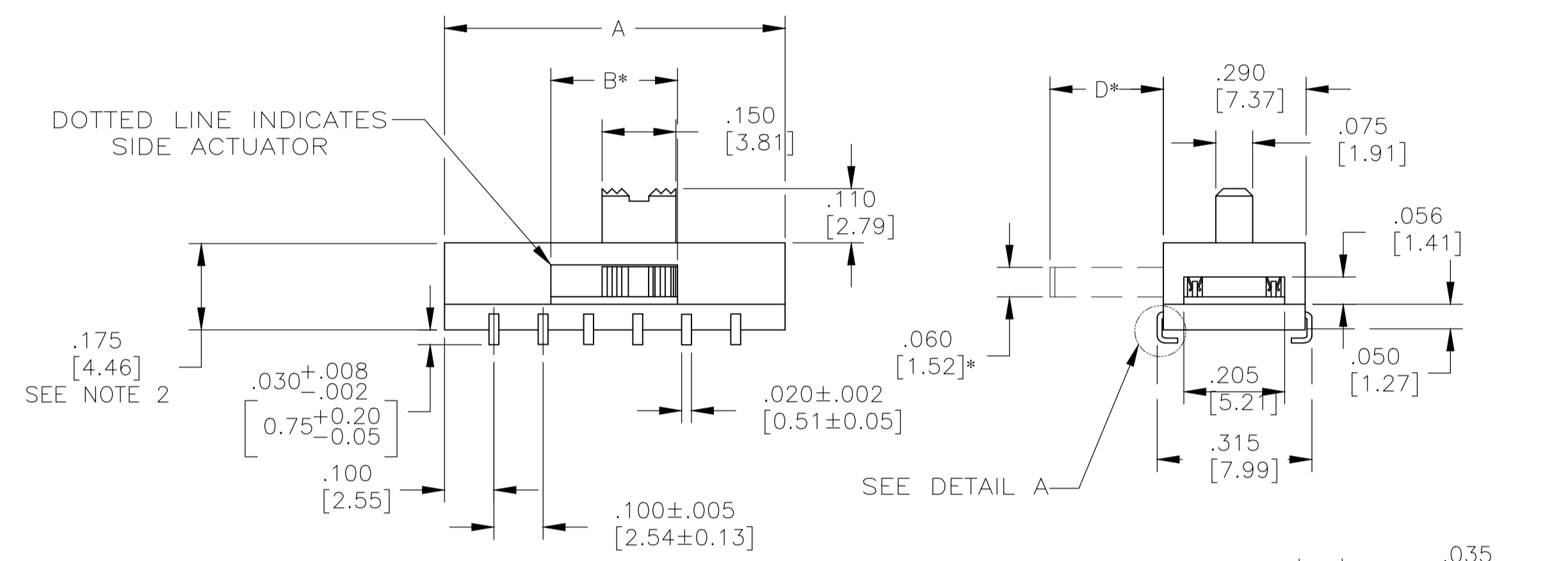

PRINTED CIRCUIT BOARD PAD LAYOUT

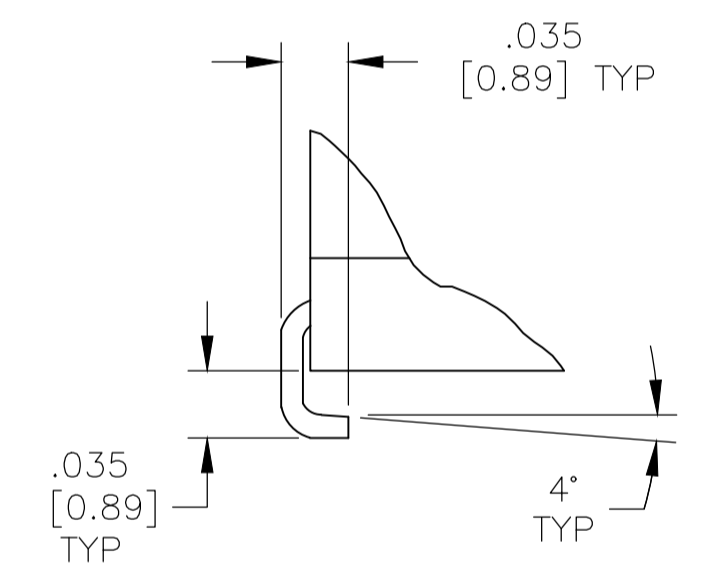

DETAIL A SCALE 10:1

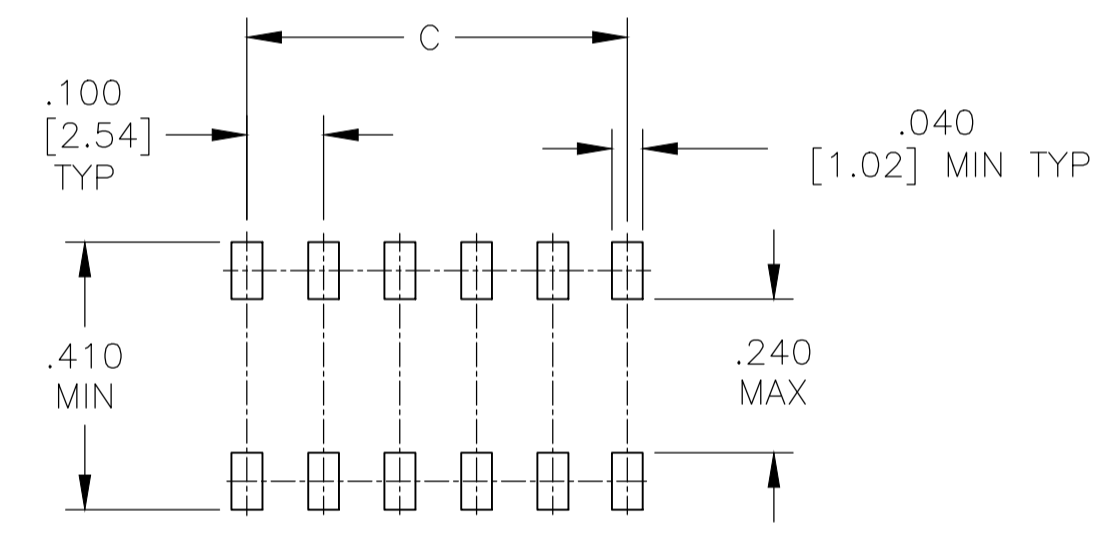

PRINTED CIRCUIT BOARD PAD LAYOUT

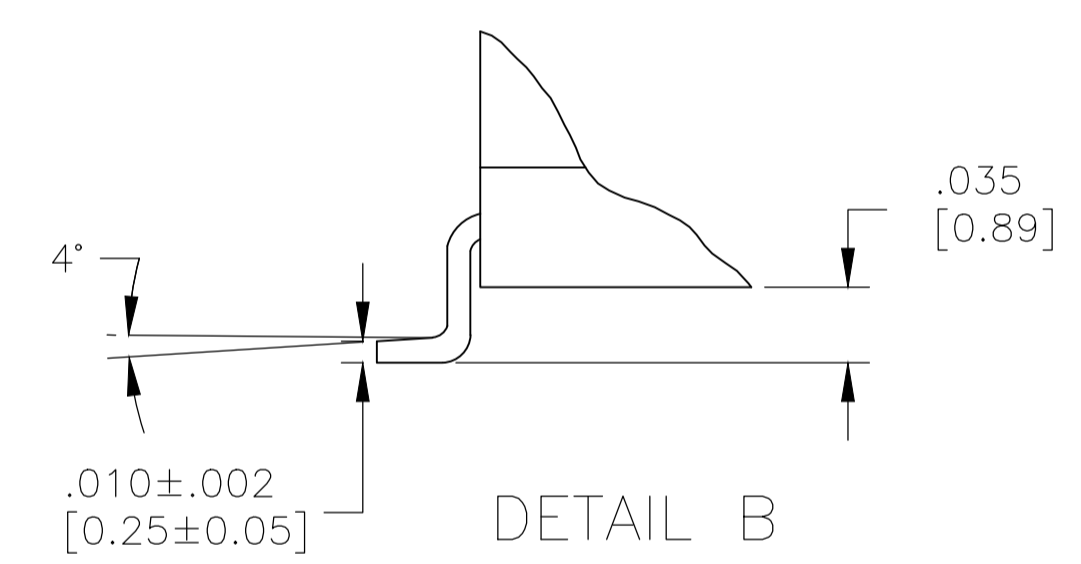

DETAIL B SCALE 10:1

"S" J-LEAD TYPE SURFACE MOUNT

"L" GULL WING TYPE SURFACE MOUNT

THIS DRAWING IS A CONTROLLED DOCUMENT.		DWG: B.S.VISWESWARA 15FEB05	TE Connectivity	
DIMENSIONS: INCHES [mm]		CHK: M.S.SARVER 15FEB05		
TOLERANCES UNLESS OTHERWISE SPECIFIED:		APP'D: M.S.SARVER 15FEB05	NAME: SLIDE SWITCH ASE/ASF, AUTO-INSERTABLE, THRU-HOLE AND SURFACE MOUNT	
0 PLC ± - 1 PLC ± - 2 PLC ± - 3 PLC ± .010 4 PLC ± - ± 1° ANGLES ± - ± 1°		APPLICATION SPEC: -		RESTRICTED TO: -
MATERIAL: SEE SHEET 1	FINISH: SEE SHEET 1	WEIGHT: A1	SIZE: 00779	DRAWING NO: 1825010
CUSTOMER DRAWING		SCALE: 4:1	SHEET: 2 OF 2	REV: B5