

- NOTES:
1. ASSURE ASSEMBLY CAPABILITY BY MATCHING WITH MATING PART
 2. DIMENSIONS IN BRACKETS ARE IN MILLIMETERS

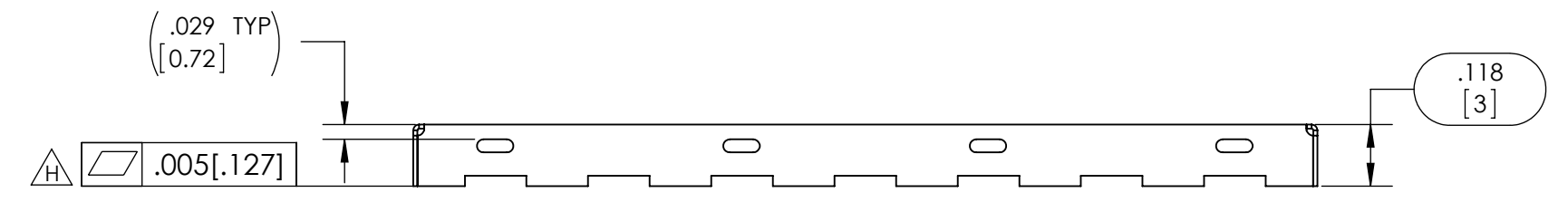

FORMED COVER

FORMED FRAME

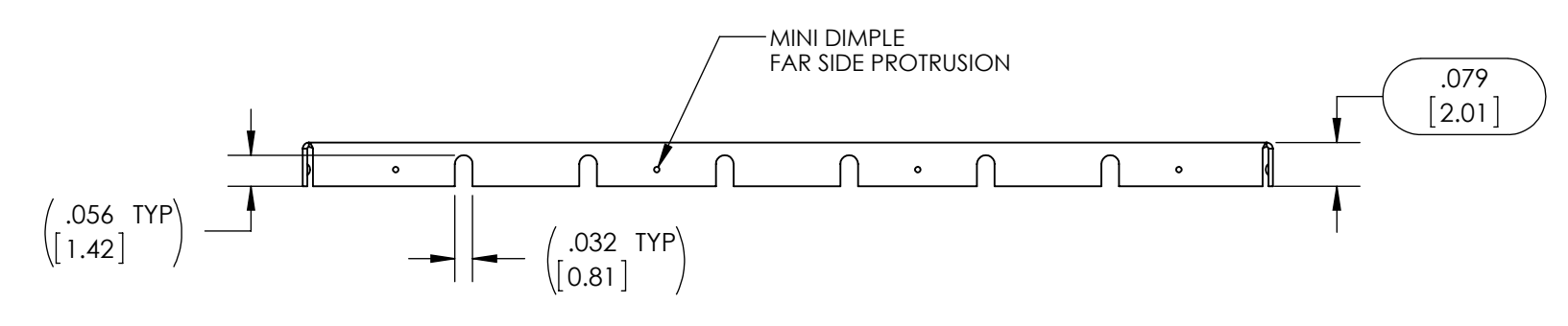
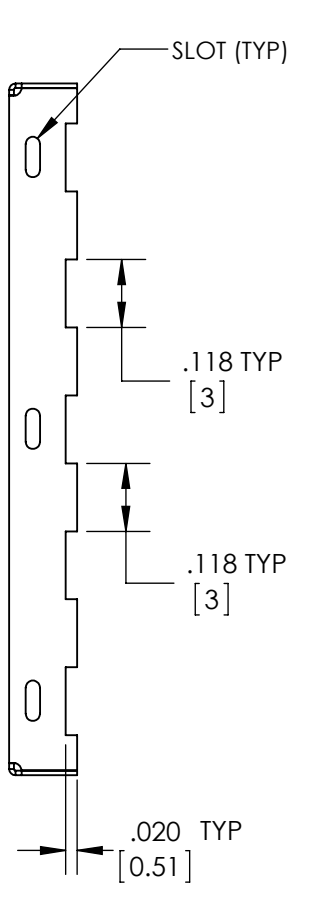
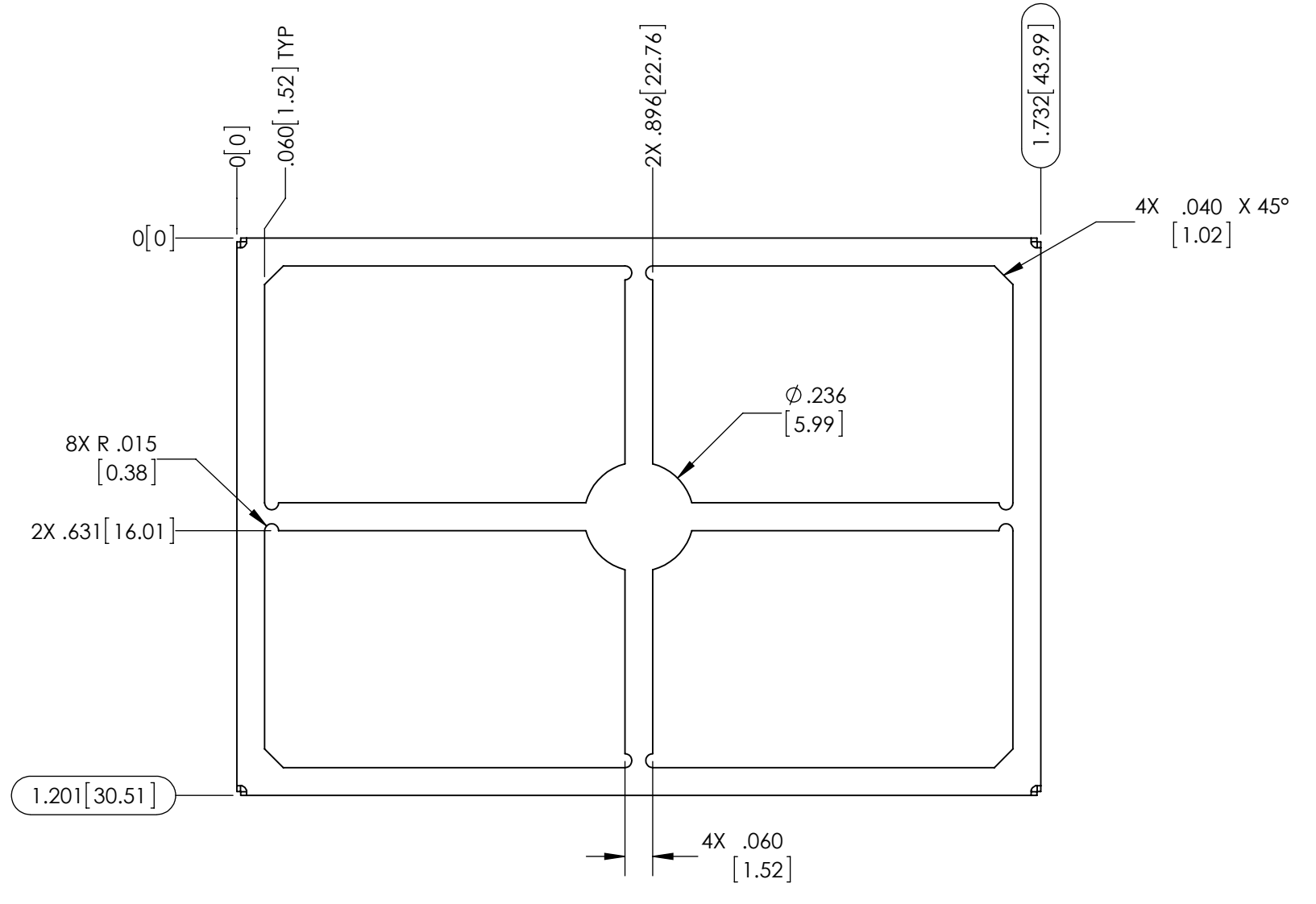
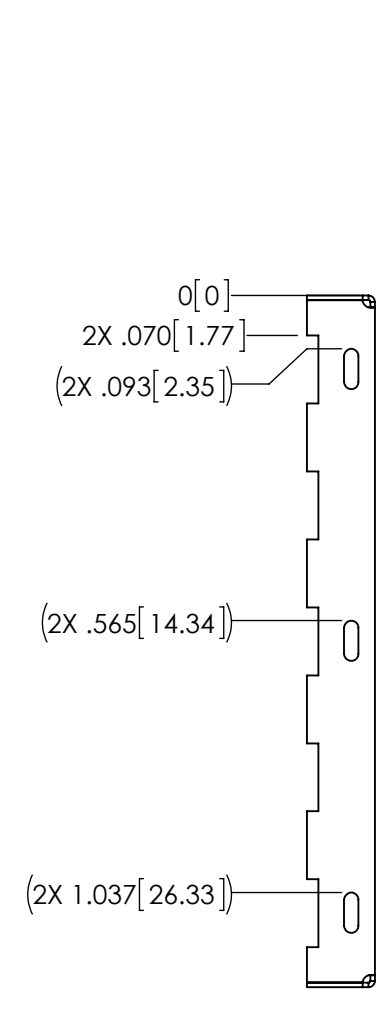
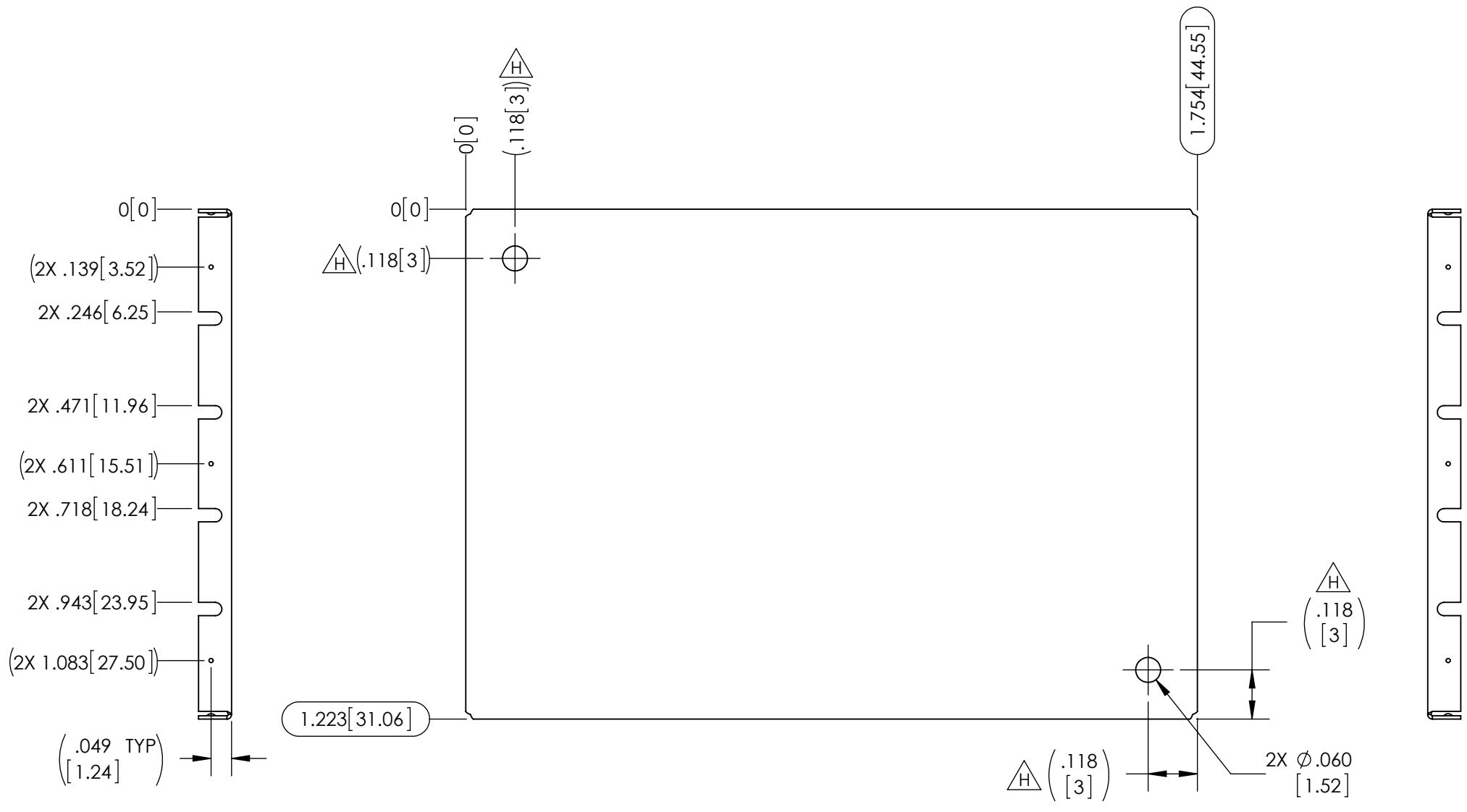
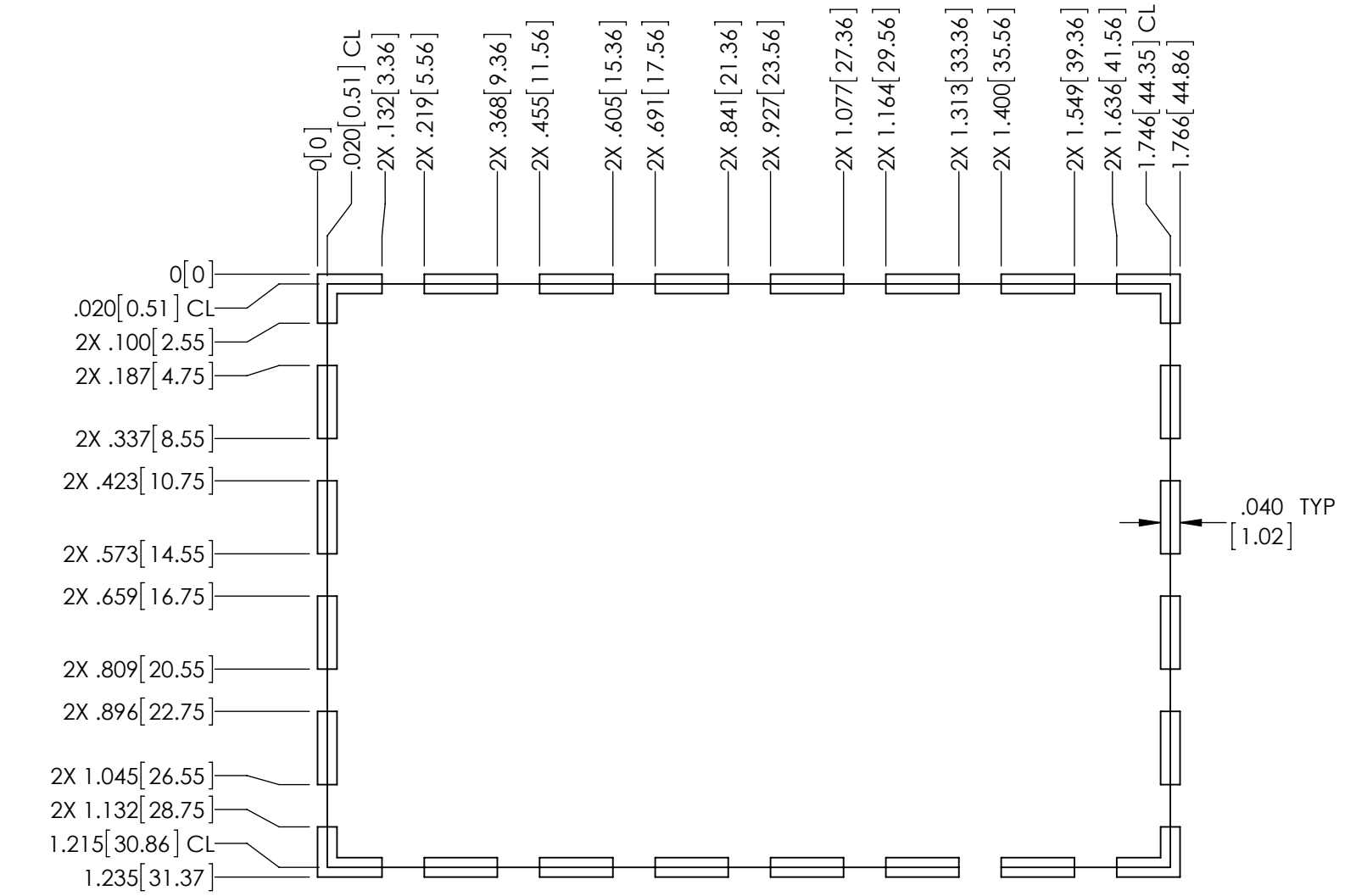
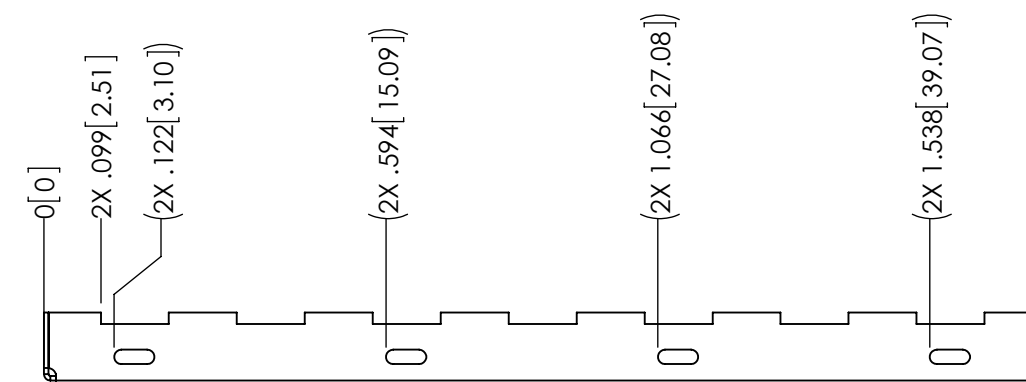
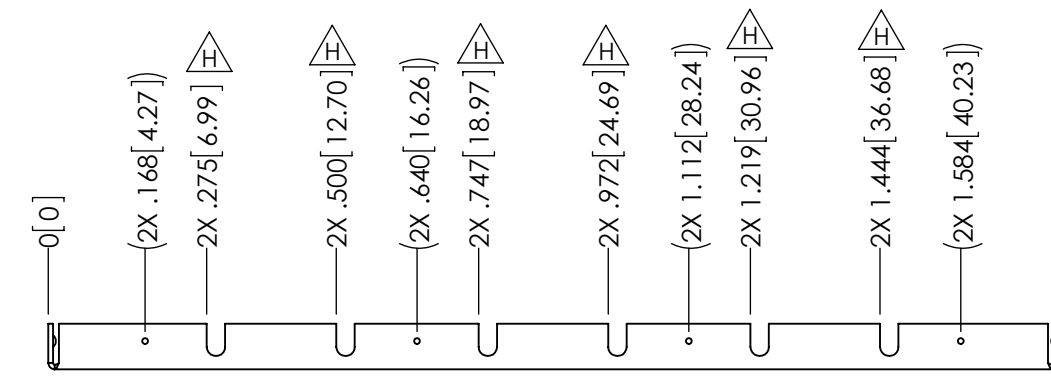
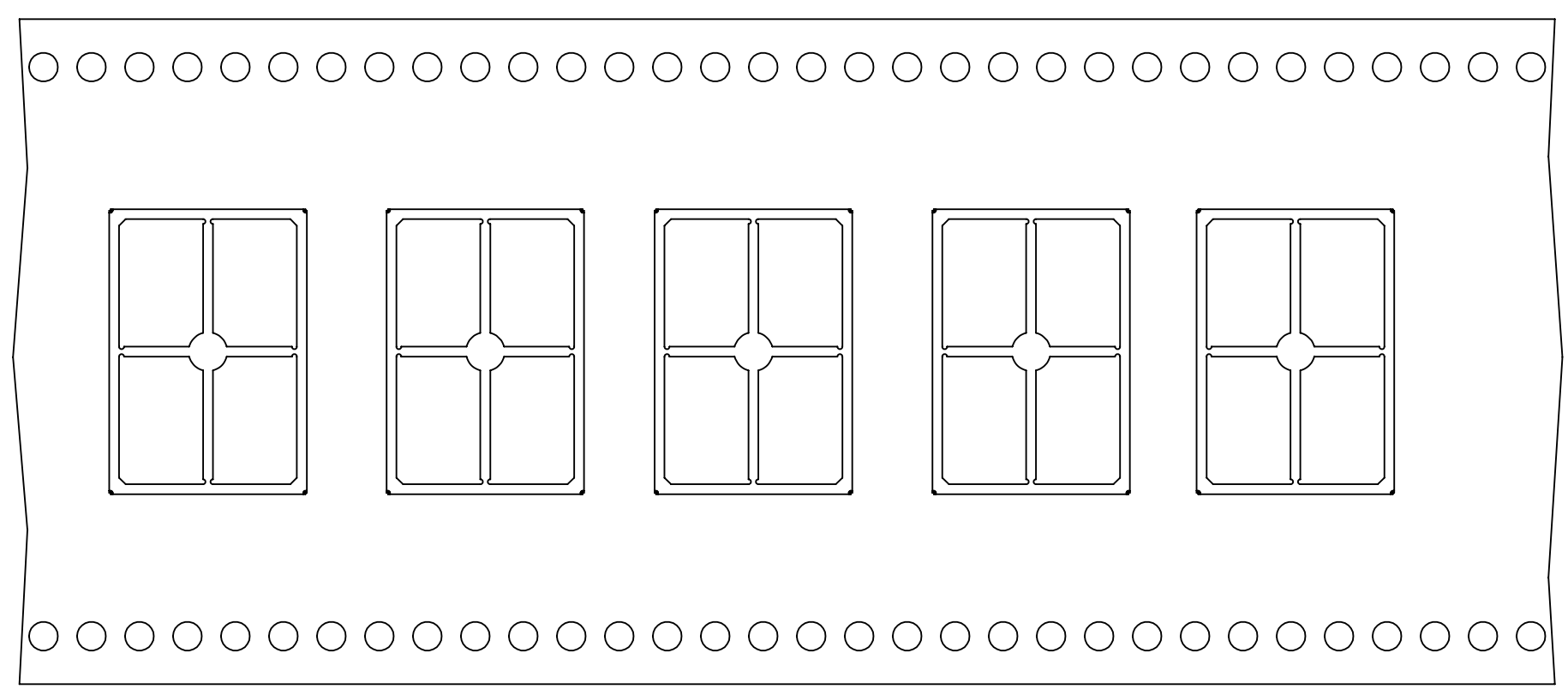
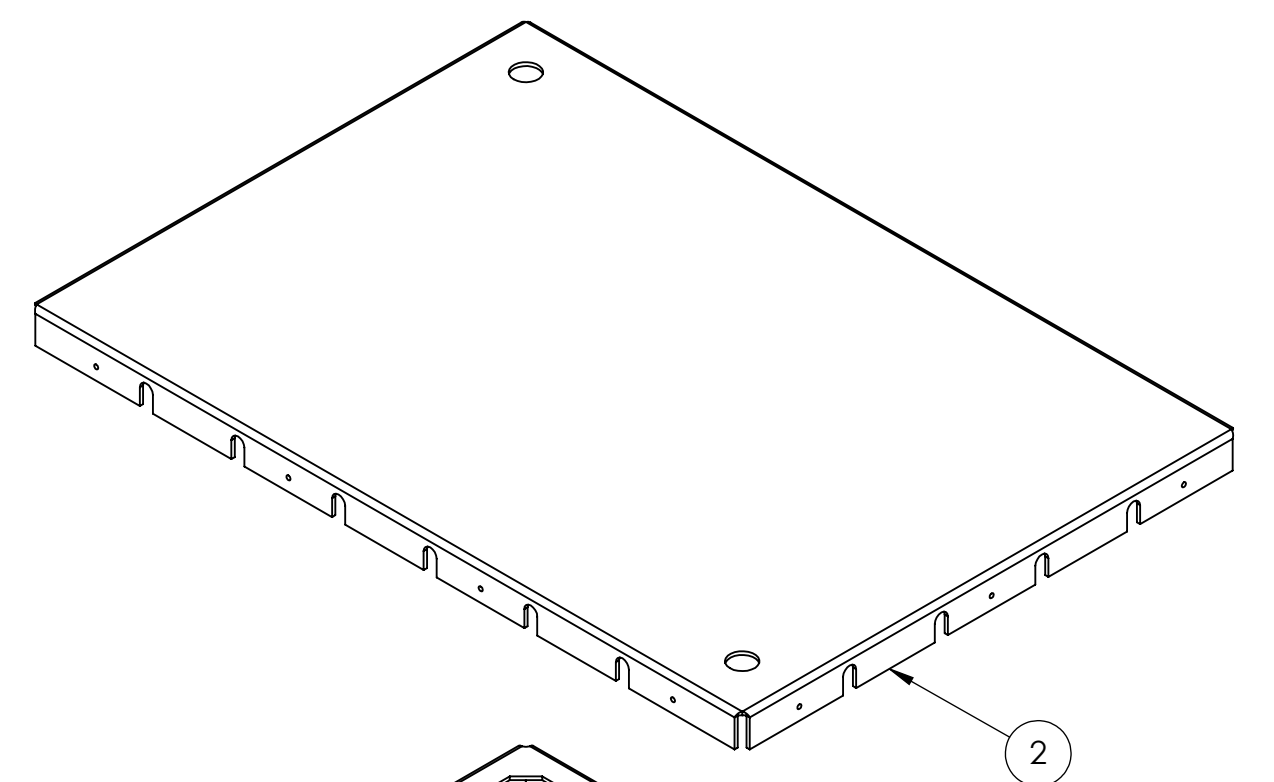

CARRIER TAPE

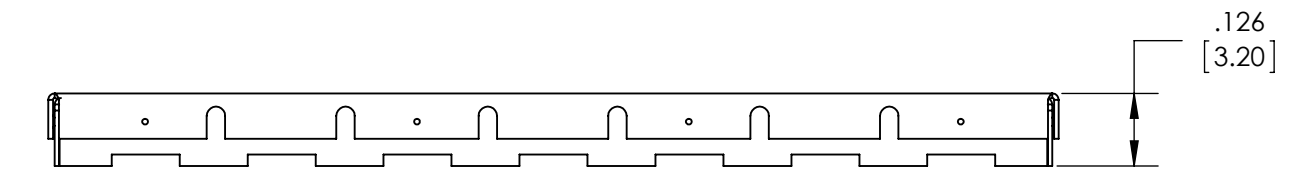

ASSEMBLY

CARRIER TAPE SPECIFICATIONS						
PART NUMBER	DESCRIPTION	OVERALL DIMENSIONS	OVERALL HEIGHT	CARRIER TAPE WIDTH	CARRIER TAPE PITCH	PARTS PER REEL
SMS-210F	FRAME	1.201 X 1.732 [30.51 X 43.99]	.118 [3.00]	72 mm	40 mm	370
SMS-210C	COVER	1.223 X 1.754 [31.06 X 44.55]	.079 [2.01]	N/A	N/A	BULK PACK

THIS DOCUMENT CONTAINS PROPRIETARY INFORMATION OWNED BY LEADERTECH OR DEVELOPED AT ITS OWN PRIVATE EXPENSE AND MAY NOT BE USED, DUPLICATED OR DISCLOSED IN WHOLE OR IN PART FOR ANY PURPOSE INCLUDING DESIGN, MANUFACTURE OR PROCUREMENT WITHOUT THE WRITTEN PERMISSION OF LEADERTECH. LEADERTECH DOES NOT GUARANTEE OR WARRANT THE PERFORMANCE CHARACTERISTICS.

ITEM NO.	PART NUMBER	DESCRIPTION	QTY.
1	SMS-210F	FRAME	1
2	SMS-210C	COVER	1

UNLESS OTHERWISE SPECIFIED:
 - ALL DIMENSIONS ARE IN INCHES
 - PART SHALL BE FREE OF BURRS AND SHARP EDGES
 - ALL DIMENSIONS SHOWN APPLY BEFORE PLATING AND COATINGS
 - ROHS COMPLIANT PER EU DIRECTIVE 2011/65/EU
 - POI = POINT OF INTERSECTION

THIRD ANGLE PROJECTION

LEADERTECH
 a HEICO company
 The Leading Edge in PAM Manufacturing Technology

TITLE: SURFACE MOUNT SHIELD

DRAWN BY: DJM 12/17/2010 APPROVED BY: -

SIZE: D DWG. NO.: SMS-210 REV: H

SCALE: 3:1 CAGE CODE: 41674 SHEET: 1 OF 1

MATERIAL: .008[0.20] PRE TIN STEEL