

SEE NOTE 14

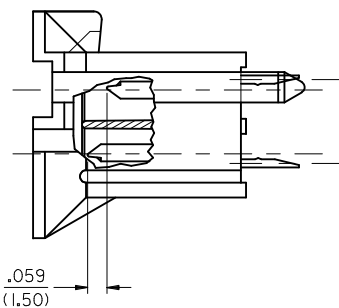

MATE-FIRST/BREAK-LAST DETAIL  
(SEE NOTE 12)

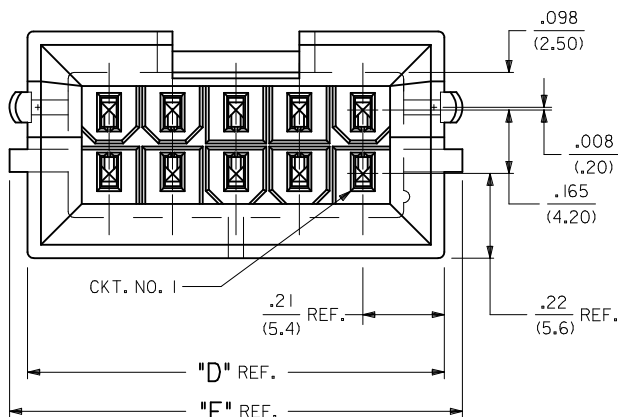
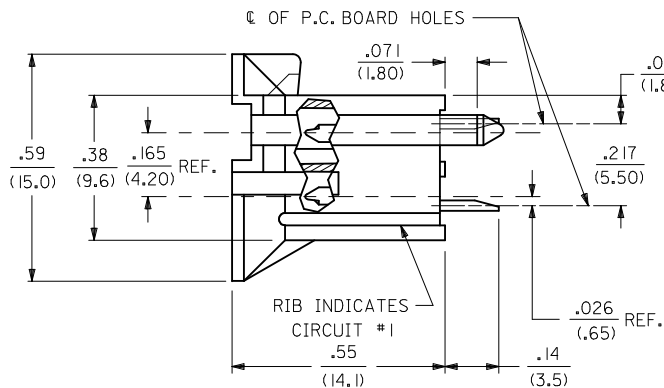
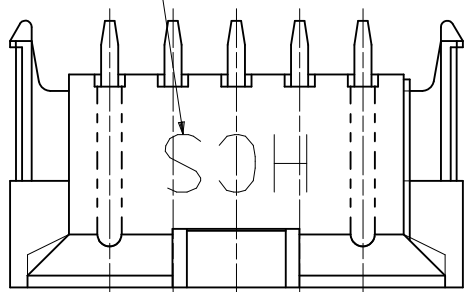
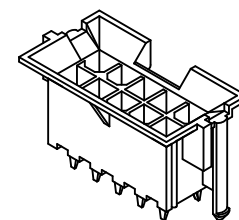

(SCALE: 2X)

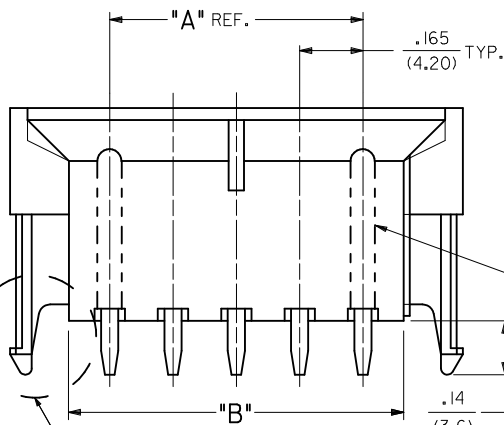

SEE NOTE 10

SEE DETAIL F  
SEE NOTE 11

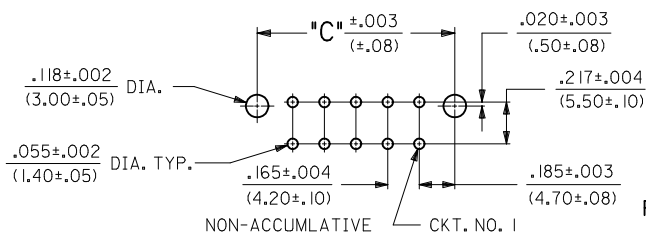

NON-ACCUMULATIVE CKT. NO. 1



DETAIL "F"  
PEG DESIGN  
PRIOR TO 8/11/97

RECOMMENDED HOLE LAYOUT FOR .070/(1.78) MAX. THICK P.C. BOARD

(SEE NOTE 5)  
(SCALE: 2X)

REMOVE TUBE P/N EC NO: UCP2010-1524 DRWN: JAGULAR 2009/12/17 CHKD: JBELL 2011/02/04 APPR: FSMITH 2011/02/11	QUALITY SYMBOLS ▽=0 ▽=0 ▽=0	GENERAL TOLERANCES (UNLESS SPECIFIED)		DIMENSION STYLE IN/MM		SCALE 4:1	DESIGN UNITS METRIC	THIRD ANGLE PROJECTION		
		mm	INCH	DRAWN BY GEP	DATE	TITLE VERTICAL HEADER ASSEMBLY MINI-FIT HCS SERIES				
		4 PLACES ± --- ± ---	3 PLACES ± --- ± .010	CHECKED BY RJF	DATE	DOCUMENT NO. SDA-44474-****				
		2 PLACES ± 0.25 ± .015	1 PLACE ± 0.38 ± ---	APPROVED BY FSMITH	DATE 2011/02/11	SHEET NO. 1 OF 5				
DRAFT WHERE APPLICABLE MUST REMAIN WITHIN DIMENSIONS		ANGULAR ±1/2°		SEE CHART		THIS DRAWING CONTAINS INFORMATION THAT IS PROPRIETARY TO MOLEX INCORPORATED AND SHOULD NOT BE USED WITHOUT WRITTEN PERMISSION				

CIRCUIT SIZE	DIM. "A"	DIM. "B"	DIM. "C"	DIM. "D"	DIM. "E"
2	---	.21 (5.4)	.370 (9.40)	.425 (10.80)	.520 (13.20)
4	.17 (4.2)	.38 (9.6)	.535 (13.60)	.590 (15.00)	.685 (17.40)
6	.33 (8.4)	.54 (13.8)	.701 (17.80)	.756 (19.20)	.850 (21.60)
8	.50 (12.6)	.71 (18.0)	.866 (22.00)	.921 (23.40)	1.016 (25.80)
10	.66 (16.8)	.87 (22.2)	1.031 (26.20)	1.087 (27.60)	1.181 (30.00)
12	.83 (21.0)	1.04 (26.4)	1.197 (30.40)	1.252 (31.80)	1.346 (34.20)
14	.99 (25.2)	1.20 (30.6)	1.362 (34.60)	1.417 (36.00)	1.512 (38.40)
16	1.16 (29.4)	1.37 (34.8)	1.528 (38.80)	1.583 (40.20)	1.677 (42.60)
18	1.32 (33.6)	1.54 (39.0)	1.693 (43.00)	1.748 (44.40)	1.843 (46.80)
20	1.49 (37.8)	1.70 (43.2)	1.858 (47.20)	1.913 (48.60)	2.008 (51.00)
22	1.65 (42.0)	1.87 (47.4)	2.024 (51.40)	2.079 (52.80)	2.173 (55.20)
24	1.82 (46.2)	2.03 (51.6)	2.189 (55.60)	2.244 (57.00)	2.339 (59.40)

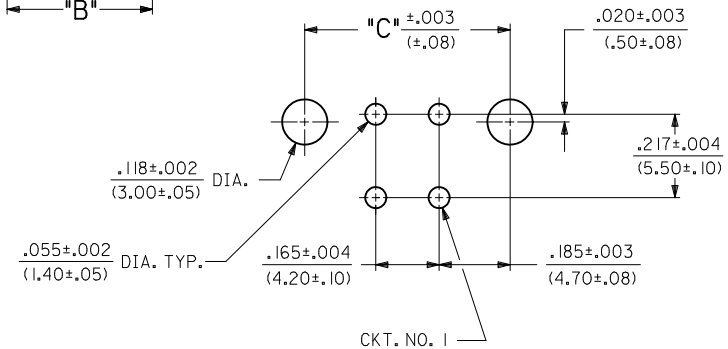
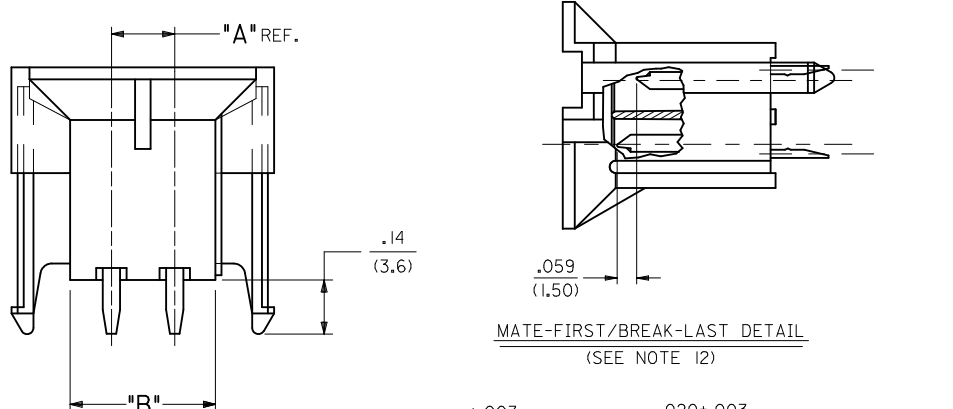
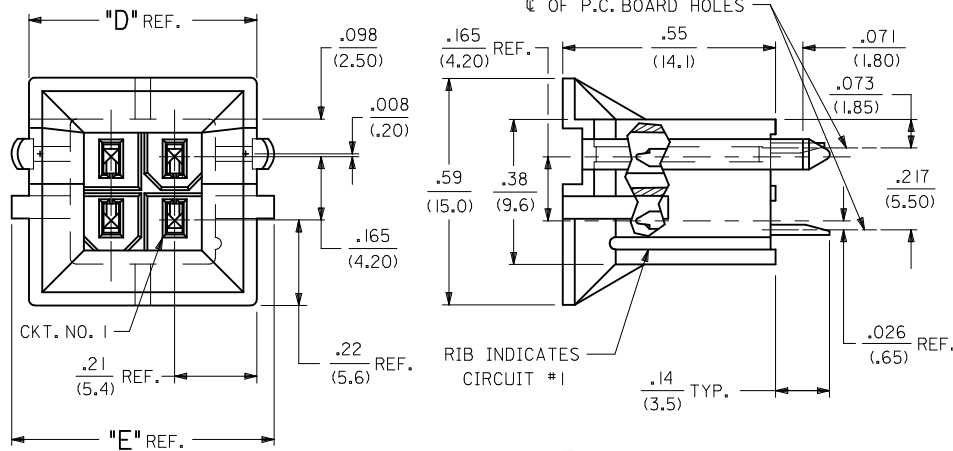

**RECOMMENDED HOLE LAYOUT FOR .070/(1.78) MAX. THICK P.C. BOARD**  
(SEE NOTE 5)

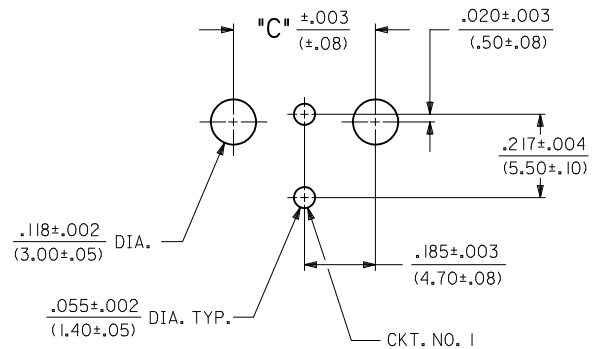
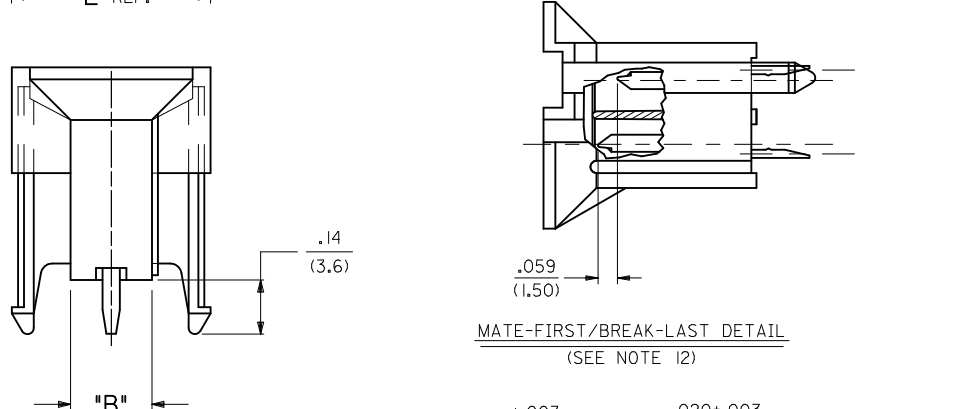
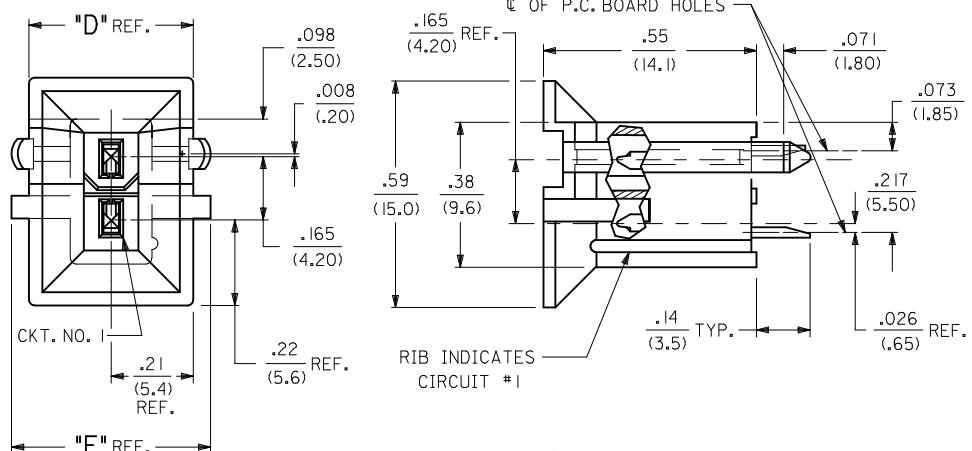

**RECOMMENDED HOLE LAYOUT FOR .070/(1.78) MAX. THICK P.C. BOARD**  
(SEE NOTE 5)

<b>SEE SHEET 1</b> EC NO: UCP2010-1524 DRWN: JAGUILAR CHKD: JBELL APPR: FSMITH 2009/12/17 2011/02/04 2011/02/11	DESCRIPTION REV G2	QUALITY SYMBOLS	GENERAL TOLERANCES (UNLESS SPECIFIED)	DIMENSION STYLE	SCALE	DESIGN UNITS	THIRD ANGLE PROJECTION	
		▽=0	mm INCH	IN/MM	4:1	METRIC	☉	
		▽=0	4 PLACES ± --- ± ---	DRAWN BY DATE	TITLE	VERTICAL HEADER ASSEMBLY MINI-FIT HCS SERIES		
		▽=0	3 PLACES ± --- ± .10	CHECKED BY DATE	MOLEX INCORPORATED			
			2 PLACES ± 0.25 ± .015	APPROVED BY DATE	DOCUMENT NO.			
			1 PLACE ± 0.38 ± ---	FSMITH 2011/02/11	SDA-44474-****			
			ANGULAR ±1/2°	SHEET NO.				
			DRAFT WHERE APPLICABLE MUST REMAIN WITHIN DIMENSIONS	2 OF 5				
				THIS DRAWING CONTAINS INFORMATION THAT IS PROPRIETARY TO MOLEX INCORPORATED AND SHOULD NOT BE USED WITHOUT WRITTEN PERMISSION				

NOTES:

- 1) HOUSING MAT'L. & OPTIONS:  
 1 = NYLON 6/6, U.L. 94V-2, COLOR: NATURAL, WITHOUT DRAIN HOLES.  
 2 = NYLON 6/6, U.L. 94V-0, COLOR: NATURAL, WITHOUT DRAIN HOLES.  
 3 = NYLON 6/6, U.L. 94V-2, COLOR: NATURAL, WITH DRAIN HOLES.  
 4 = NYLON 6/6, U.L. 94V-0, COLOR: NATURAL, WITH DRAIN HOLES.
- 2) TERMINAL MAT'L.: COPPER ALLOY
- 3) 6-24 CKT. PARTS MATE WITH MINI-FIT JR. RECEPT.#5557, H.C.S. VERT. HEADER #44475 AND B.M.I. HEADER #42474. 2 & 4 CKT. PARTS MATE WITH HEADERS ONLY.
- 4) PART ALLOWS FOR UP TO .100/(2.54) MISALIGNMENT WITH MATING RECEPTACLE IN ANY DIRECTION. SEE MATING CONNECTOR DRAWINGS FOR SPECIFIC ALLOWANCES.
- 5) PART IS DESIGNED IN METRIC.
- 6) TERMINAL PLATING:  
 1 = POSTPLATE .000100/(.00254) MIN. BRIGHT TIN OVER .000050/(.00127) MIN. NICKEL.
- 7) PRODUCT SPECIFICATION AND PROCESSING PARAMETERS: SEE PS-44476-001.
- 8) CONNECTOR ASSEMBLIES ARE NOT TO BE MATED OR UNMATED WHILE CIRCUITS ARE LIVE.
- 9) ITEM NUMBERS PRECEDED BY AN "X" IN THE CHARTS ON THE FOLLOWING SHEETS ARE NOT AVAILABLE.
- 10) OPTIONAL RIBS MAY BE FOUND ON PARTS MANUFACTURED AFTER 08/11/97.
- 11) PARTS MANUFACTURED AFTER 8/15/97 MAY HAVE REVISED LOCK PEG.
- 12) CIRCUITS SHOWN PROVIDE CUSTOM MATE-FIRST/BREAK-LAST FEATURE. SEE CHART ON SHEET SIX FOR ASSEMBLIES WITH ADDITIONAL CUSTOM OPTIONS.
- 13) PACKAGING:  
 1 = TRAY PER PK-42440-001.
- 14) PARTS PRODUCED AFTER JULY 1, 2004 WILL HAVE "HCS" MARKING INSTEAD OF BLACK STRIPE.
- 15) PART CONFORMS TO CLASS "B" REQUIREMENTS OF COSMETIC SPECIFICATION PS-45499-002

SEE SHEET 1 EC NO: UCP2010-1524 DRWN: JAGUILAR 2009/12/17 CHKD: JELL 2011/02/04 APPR: FSMITH 2011/02/11	DESCRIPTION REV	QUALITY SYMBOLS	GENERAL TOLERANCES (UNLESS SPECIFIED)	DIMENSION STYLE IN/MM		SCALE	DESIGN UNITS METRIC	THIRD ANGLE PROJECTION		
		▽=0	4 PLACES ± --- ± ---	mm	INCH	DRAWN BY	DATE	TITLE VERTICAL HEADER ASSEMBLY MINI-FIT HCS SERIES		
		▽=0	3 PLACES ± --- ± .010			CHECKED BY	DATE			
		▽=0	2 PLACES ± 0.25 ± .015			APPROVED BY	DATE	 MOLEX INCORPORATED DOCUMENT NO. SDA-44474-**** SHEET NO. 3 OF 5		
	1 PLACE ± 0.38 ± ---			FSMITH	2011/02/11					
DRAFT WHERE APPLICABLE MUST REMAIN WITHIN DIMENSIONS			ANGULAR ± 1/2°		MATERIAL NO.		SIZE			
			SEE CHART		THIS DRAWING CONTAINS INFORMATION THAT IS PROPRIETARY TO MOLEX INCORPORATED AND SHOULD NOT BE USED WITHOUT WRITTEN PERMISSION					

PLATING:	I (SEE NOTE 6)		PLATING:	I (SEE NOTE 6)		PLATING:	I (SEE NOTE 6)		PLATING:	I (SEE NOTE 6)		PLATING:		
DRAINS:	WITHOUT DRAIN HOLES		DRAINS:	WITHOUT DRAIN HOLES		DRAINS:	WITH DRAIN HOLES		DRAINS:	WITH DRAIN HOLES		DRAINS:		
PEGS:	WITH PEGS		PEGS:	WITH PEGS		PEGS:	WITH PEGS		PEGS:	WITH PEGS		PEGS:		
MAT'L:	94V-2 [NATURAL]		MAT'L:	94V-0 [NATURAL]		MAT'L:	94V-2 [NATURAL]		MAT'L:	94V-0 [NATURAL]		MAT'L:		
PACKAGING:	TRAY (SEE NOTE 13)		PACKAGING:	TRAY (SEE NOTE 13)		PACKAGING:	TRAY (SEE NOTE 13)		PACKAGING:	TRAY (SEE NOTE 13)		PACKAGING:		
	ITEM NO.	CKTS		ITEM NO.	CKTS		ITEM NO.	CKTS		ITEM NO.	CKTS		ITEM NO.	CKTS
X	44474-0211	2	X	44474-0221	2	X	44474-0231	2	X	44474-0241	2			
	44474-0411	4		44474-0421	4		44474-0431	4		44474-0441	4			
	44474-0611	6	X	44474-0621	6	O	44474-0631	6	X	44474-0641	6			
X	44474-0811	8	X	44474-0821	8	X	44474-0831	8	X	44474-0841	8			
	44474-1011	10		44474-1021	10		44474-1031	10		44474-1041	10			
X	44474-1211	12	X	44474-1221	12	X	44474-1231	12	X	44474-1241	12			
	44474-1411	14		44474-1421	14		44474-1431	14		44474-1441	14			
X	44474-1611	16	X	44474-1621	16	X	44474-1631	16	X	44474-1641	16			
	44474-1811	18		44474-1821	18		44474-1831	18		44474-1841	18			
X	44474-2011	20	X	44474-2021	20	X	44474-2031	20	X	44474-2041	20			
X	44474-2211	22	X	44474-2221	22	X	44474-2231	22	X	44474-2241	22			
	44474-2411	24		44474-2421	24		44474-2431	24		44474-2441	24			

PLATING:			PLATING:			PLATING:			PLATING:			PLATING:		
DRAINS:			DRAINS:			DRAINS:			DRAINS:			DRAINS:		
PEGS:			PEGS:			PEGS:			PEGS:			PEGS:		
MAT'L:			MAT'L:			MAT'L:			MAT'L:			MAT'L:		
PACKAGING:			PACKAGING:			PACKAGING:			PACKAGING:			PACKAGING:		
	ITEM NO.	CKTS		ITEM NO.	CKTS		ITEM NO.	CKTS		ITEM NO.	CKTS		ITEM NO.	CKTS
		2			2			2			2			2
		4			4			4			4			4
		6			6			6			6			6
		8			8			8			8			8
		10			10			10			10			10
		12			12			12			12			12
		14			14			14			14			14
		16			16			16			16			16
		18			18			18			18			18
		20			20			20			20			20
		22			22			22			22			22
		24			24			24			24			24

\* ITEMS PRECEDED BY "X" ARE NOT AVAILABLE  
 ITEMS ON THIS PAGE ARE STANDARD PRODUCT. REFER TO  
 SHEET SIX FOR PRODUCT WITH CUSTOM OPTIONS.  
 \*O" = OBSOLETE

SEE SHEET 1 EC NO: UCP2010-1524 DRWN: JAGUILAR CHKD: JELL APPR: FSMITH	2009/12/17 2011/02/04 2011/02/11	DESCRIPTION REV	QUALITY SYMBOLS	GENERAL TOLERANCES (UNLESS SPECIFIED)	DIMENSION STYLE	SCALE	DESIGN UNITS	THIRD ANGLE PROJECTION
			▽=0	mm INCH	IN/MM	METRIC	☉	
			▽=0	4 PLACES ± --- ± ---	DRAWN BY DATE	TITLE		
			▽=0	3 PLACES ± --- ± .010	CHECKED BY DATE	VERTICAL HEADER ASSEMBLY MINI-FIT HCS SERIES		
			2 PLACES ± 0.25 ± .015	APPROVED BY DATE	MOLEX INCORPORATED			
			1 PLACE ± 0.38 ± ---	FSMITH 2011/02/11	SDA-44474-****			
			ANGULAR ±1/2°	MATERIAL NO.	DOCUMENT NO.			
			DRAFT WHERE APPLICABLE MUST REMAIN WITHIN DIMENSIONS	SEE CHART	SHEET NO. 4 OF 5			
				SIZE C	THIS DRAWING CONTAINS INFORMATION THAT IS PROPRIETARY TO MOLEX INCORPORATED AND SHOULD NOT BE USED WITHOUT WRITTEN PERMISSION			

ITEM NO.	CHARACTERISTIC DESCRIPTION	TERMINAL VERSION REQUIRED AT EACH CIRCUIT LOCATION: (SEE CODES AT RIGHT)																								TERM. CODES FOR CHART AT LEFT				
		1	2	3	4	5	6	7	8	9	10	11	12	13	14	15	16	17	18	19	20	21	22	23	24	TERMINAL NO.	PLATING /	MATERIAL		
J	44474-5000	I	I	3	I	I	I	I	I	I	I	I	I	3	3	3	-	-	-	-	-	-	-	-	-	-	-	* - * = VOID	N/A	N/A
																												* I * = MAKE-FIRST	I	C I97
																												* 3 * = STANDARD	I	C I97
I																														
H																														
G																														
F																														
E																														
D																														
C																														

CHARACTERISTICS LEGEND:  
FOR ASSEMBLIES ON THIS SHEET ONLY

CIRCUIT SIZE: \_\_\_\_\_  
(02-24)

HOUSING MATERIAL AND OPTIONS: \_\_\_\_\_  
\*1\*=NYLON 6/6, U.L. 94V-2, COLOR: NATURAL, W/O DRAIN HOLES.  
\*2\*=NYLON 6/6, U.L. 94V-0, COLOR: NATURAL, W/O DRAIN HOLES.

TERMINAL MATERIAL: \_\_\_\_\_  
\*A\*= C I97 ALLOY

TERMINAL PLATING (SEE NOTE 6): \_\_\_\_\_  
\*I\* = 100u" MIN. BRIGHT TIN OVER 30u" MIN. NICKEL

PACKAGING (SEE NOTE 13): \_\_\_\_\_  
\*I\* = TRAY

\*\* \* \* \* \*

SEE SHEET 1 EC NO: UCP2010-1524 DRWN: JAGUILAR CHKD: J.BELL APPR: FSMITH	2009/12/17 2011/02/04 2011/02/11	DESCRIPTION REV	QUALITY SYMBOLS ▽=0 ▽=0 ▽=0	GENERAL TOLERANCES (UNLESS SPECIFIED)		DIMENSION STYLE IN/MM		SCALE	DESIGN UNITS METRIC	THIRD ANGLE PROJECTION	
				4 PLACES ± --- ± ---	3 PLACES ± --- ± .010	2 PLACES ± 0.25 ± .015	1 PLACE ± 0.38 ± ---	ANGULAR ± 1/2°	DRAWN BY GEP	DATE	TITLE VERTICAL HEADER ASSEMBLY MINI-FIT HCS SERIES
DRAFT WHERE APPLICABLE MUST REMAIN WITHIN DIMENSIONS				MATERIAL NO. SEE CHART		APPROVED BY FSMITH		DATE 2011/02/11		DOCUMENT NO. SDA-44474-****	
				SIZE C		THIS DRAWING CONTAINS INFORMATION THAT IS PROPRIETARY TO MOLEX INCORPORATED AND SHOULD NOT BE USED WITHOUT WRITTEN PERMISSION					